

DIAGNOSIS AND TESTING

Accessory Drive

Inspection and Verification

⚠ CAUTION: Under no circumstances should the accessory drive belt, tensioner or pulleys be lubricated as potential damage to the belt material and tensioner damping mechanism will occur. Do not apply any fluids or belt dressing to the accessory drive belt or pulleys.

1. Verify the customer concern by operating the system.
2. Visually inspect for obvious signs of mechanical damage.

Visual Inspection Chart

Mechanical
<ul style="list-style-type: none"> • Drive belt cracking/chunking/wear • Belt/pulley contamination • Incorrectly routed belt • Pulley misalignment or excessive pulley runout • Loose or mislocated hardware • Incorrectly routed power steering tubes (rubbing)

3. Eliminate all other non-belt related noises that could cause belt misdiagnosis, such as A/C compressor engagement chirp, power steering cavitations at low temperatures, variable camshaft timing (VCT) tick or generator whine.
4. If a concern is found, correct the condition before proceeding to the next step.

V-Ribbed Serpentine Drive Belt With Cracks Across Ribs

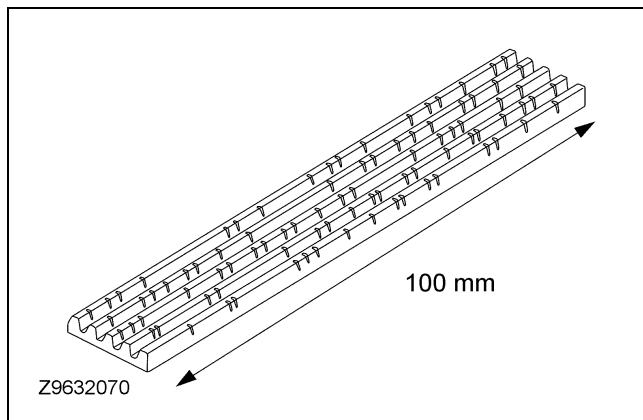

5. **NOTE:** Up to 15 cracks in a rib over a distance of 100 mm (4.0 in) can be considered acceptable. If damage exceeds the acceptable limit or any chunks are found to be missing from the ribs, a new belt must be installed.

Check the belt for cracks. Up to 15 cracks in a rib over a distance of 100 mm (4.0 in) can be considered acceptable. If cracks exceed this standard, install a new belt.

6. The condition of the V-ribbed drive belt should be compared against the illustration and appropriate action taken.
 - 1 Small scattered deposits of rubber material. This is not a concern, therefore, installation of a new belt is not required.
 - 2 Longer deposit areas building up to 50% of the rib height. This is not considered a concern but it can result in excessive noise. If noise is apparent, install a new belt.
 - 3 Heavy deposits building up along the grooves resulting in a possible noise and belt stability concern. If heavy deposits are apparent, install a new belt.

DIAGNOSIS AND TESTING (Continued)

V-Ribbed Serpentine Belt With Piling

NOTE: Piling is an excessive buildup in the V-grooves of the belt.

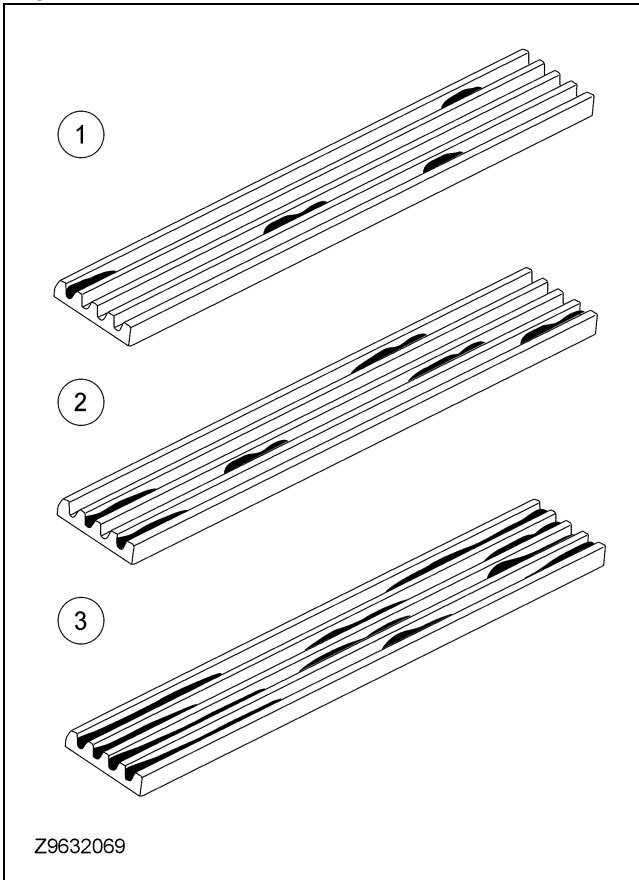

7. There should be no chunks missing from the belt ribs. If the belt shows any evidence of this, install a new accessory drive belt.

V-Ribbed Serpentine Belt With Chunks of Rib Missing

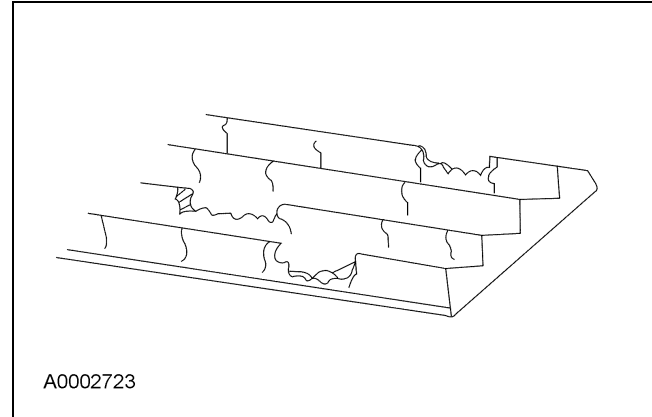

8. If the concern is not visually evident, verify the symptom and GO to [Symptom Chart](#).

Symptom Chart

Symptom Chart

Condition	Possible Sources	Action
<ul style="list-style-type: none"> Accessory drive belt cracking (over 15 cracks in a rib over a distance of 100 mm [4.0 in]) 	<ul style="list-style-type: none"> Accessory drive belt 	<ul style="list-style-type: none"> INSPECT the accessory drive belt. REFER to Inspection and Verification in this section. INSTALL a new accessory drive belt as necessary.
<ul style="list-style-type: none"> Accessory drive belt chunking 	<ul style="list-style-type: none"> Accessory drive belt 	<ul style="list-style-type: none"> INSPECT the accessory drive belt. REFER to Inspection and Verification in this section. INSTALL a new accessory drive belt as necessary.

DIAGNOSIS AND TESTING (Continued)**Symptom Chart (Continued)**

Condition	Possible Sources	Action
<ul style="list-style-type: none"> Accessory drive belt noise, squeal, chirping or flutter 	<ul style="list-style-type: none"> Defective/worn or incorrect accessory drive belt Misaligned pulley(s) Pulley runout Damaged or worn accessories Fluid contamination of accessory drive belt or pulleys Damaged or worn accessory drive belt tensioner 	<ul style="list-style-type: none"> REFER to Component Tests, Drive Belt, Noise/Flutter in this section. REPAIR or INSTALL new parts as necessary. REFER to Component Tests, Belt Tensioner — Mechanical and Belt Tensioner — Dynamics in this section. INSTALL a new accessory drive belt tensioner as necessary.
<ul style="list-style-type: none"> Premature accessory drive belt wear 	<ul style="list-style-type: none"> Defective accessory drive belt Misaligned pulley(s) Pulley runout Damaged accessories Incorrectly installed drive belt Fluid contamination 	<ul style="list-style-type: none"> REFER to Component Tests, Drive Belt Noise/Flutter and Incorrect Drive Belt Installation in this section. REPAIR or INSTALL new parts as necessary.
<ul style="list-style-type: none"> Accessory drive belt does not hold proper tension 	<ul style="list-style-type: none"> Accessory drive belt has excessive cracking or damage Drive belt tensioner worn or damaged Accessory drive component failure Accessory drive belt idler pulley bearing failure 	<ul style="list-style-type: none"> INSPECT the drive belt. REFER to Inspection and Verification in this section. INSTALL a new drive belt as necessary. CHECK the drive belt tensioner for damage and correct operation. REFER to the Component Tests, Belt Tensioner — Mechanical and Belt Tensioner — Dynamics in this section. INSTALL a new drive belt tensioner as necessary. CHECK the accessory drive components. INSTALL new components as necessary. INSPECT the accessory drive belt idler pulley for freedom of rotation and damage. INSTALL a new accessory drive belt idler pulley as necessary.

Component Tests**Drive Belt — Noise/Flutter**

Drive belt chirp occurs due to pulley misalignment or excessive pulley runout. It can be the result of a damaged or an incorrectly aligned grooved pulley.

To correct, determine the area where the noise comes from. Check each of the pulleys in that area with a straightedge to the crankshaft pulley. Look for accessory pulleys out of position in the fore/aft direction or at an angle to the straightedge.

 **CAUTION: Do not apply any fluids or belt dressing to the accessory drive belt or pulleys.**

Drive belt squeal may be an intermittent or constant noise that occurs when the drive belt slips on an accessory pulley under certain conditions.

A short intermittent squeal may occur during engine start-up and shut down or during very rapid engine acceleration and decelerations, such as:

- wide open throttle 1-2 and 2-3 shifts or 2-3 and 3-4 back out shifts on automatic transmissions.

DIAGNOSIS AND TESTING (Continued)

- wide open throttle 1-2 and 2-3 shifts and any combination of rapid downshifting on manual transmissions.

These special short-term transient events are expected, and are due to the higher system inertias required to meet the electrical and cooling demands on today's vehicle systems. Constant or reoccurring drive belt squeal can occur:

- if the A/C discharge pressure goes above specifications:
 - the A/C system is overcharged.
 - the A/C condenser core airflow is blocked.
- if the A/C OFF equalized pressure (the common discharged and suction pressure that occurs after several minutes) exceeds specifications.
- if any of the accessories are damaged or have a worn or damaged bearing. All accessories should be rotatable by hand in the unloaded condition. If not, inspect the accessory.
- if there is evidence of fluid contamination on the accessory drive belt. When the drive belt has been exposed to fluid contamination during vehicle operation, such as leaks from the power steering system, A/C system or cooling system, clean all pulleys with soap and water, rinse with clean water and install a new accessory drive belt. If the drive belt has been exposed to fluids in a localized area during routine vehicle service, such as replacement of hoses or fluids, the drive belt and pulleys should be washed with soap and water immediately (prior to starting the engine), and rinsed with clean water.
- if the accessory drive belt is too long. A drive belt that is too long will allow the accessory drive belt tensioner arm to go all the way to the arm travel stop under certain load conditions, which will release tension to the drive belt. If the accessory drive belt tensioner indicator is outside the normal installation wear range window, install a new accessory drive belt.
- **NOTE:** The accessory drive belt tensioner arm should rotate freely without binding.

Install a new accessory drive belt tensioner if the drive belt tensioner is worn or damaged.

Drive Belt — Incorrect Installation

⚠ CAUTION: Incorrect accessory drive belt installation will cause excessive drive belt wear and can cause the drive belt to come off the pulleys.

Non-standard accessory drive belts can track differently or incorrectly. If an accessory drive belt tracks incorrectly, install a new accessory drive belt to avoid performance failure or loss of the drive belt.

Incorrect Installation

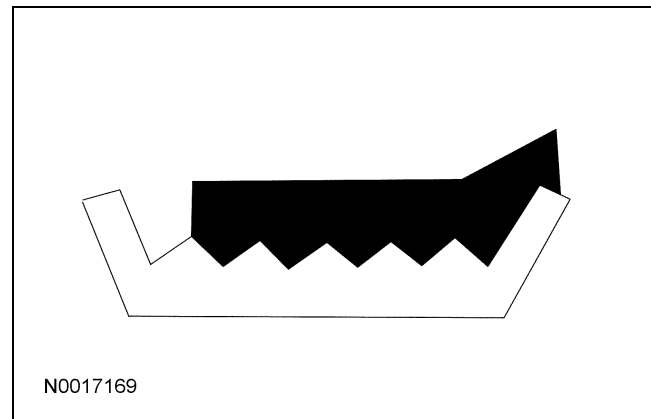

Correct Installation

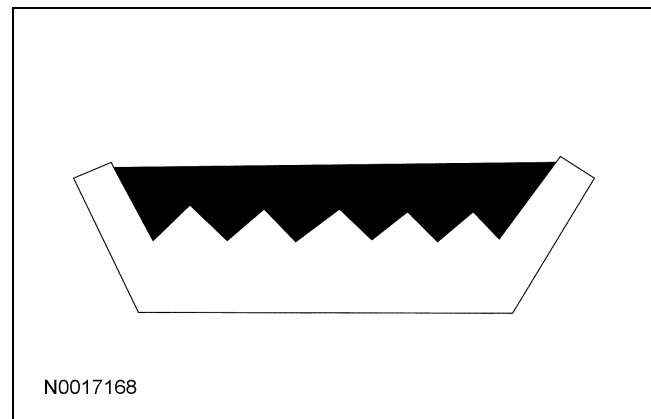

DIAGNOSIS AND TESTING (Continued)

With the engine running, check accessory drive belt tracking on all pulleys. If the edge of the accessory drive belt rides beyond the edge of the pulleys, noise and premature wear will occur. Make sure the accessory drive belt rides correctly on the pulley. If an accessory drive belt tracking condition exists, proceed with the following:

- Visually check the accessory drive belt tensioner for damage, especially the mounting pad surface. If the accessory drive belt tensioner is not installed correctly, the mounting surface pad will be out of position. This will result in chirp and squeal noises.
- With the engine running, visually observe the grooves in the pulleys (not the pulley flanges or the pulley forward faces) for excessive wobble. Install new components as necessary.
- Check all accessories, mounting brackets and the accessory drive belt tensioner for any interference that would prevent the component from mounting correctly. Correct any interference condition and recheck the accessory drive belt tracking.
- Tighten all accessories, mounting brackets and accessory drive belt tensioner retaining hardware to specification. Recheck the accessory drive belt tracking.

Belt Tensioner — Mechanical

The only mechanical check that needs to be made is a check for tensioner stick, grab or bind.

1. With the engine OFF, check routing of the accessory drive belt. Refer to the illustrations under Description and Operation in this section.
2. **NOTE:** The accessory drive belt tensioner spring is very strong and requires substantial force to release.

Using a suitable, commercially available serpentine belt tensioner release tool, release the tension on the belt and detach the accessory drive belt in the area of the tensioner.

3. Using a suitable, commercially available serpentine belt tensioner release tool, move the tensioner from its relaxed position, through its full stroke and back to the relaxed position to make sure there is no stick, grab or bind, and to make sure that there is tension on the tensioner spring.
4. Rotate the tensioner pulley by hand and check for a binding, contaminated or seized condition. Install a new accessory drive belt tensioner if necessary.
5. Inspect the area surrounding the accessory drive belt tensioner for oil leaks or contamination and repair any leaks. Install a new accessory drive belt tensioner as necessary.
6. If the accessory drive belt tensioner meets the above criteria, proceed to testing the tensioner dynamically. If the accessory drive belt tensioner does not meet the above criteria, install a new tensioner.

Belt Tensioner — Dynamics

The accessory drive belt tensioner can be checked dynamically as follows:

1. With the engine running, observe the accessory drive belt tensioner movement. The accessory drive tensioner should move (respond) when the air conditioning clutch cycles (if equipped), or when the engine is accelerated rapidly. If the accessory drive belt tensioner movement is excessive without air conditioning clutch cycling or engine acceleration, check belt rideout. Excessive belt rideout (uneven depth of grooves in the belt) can cause excessive accessory drive belt tensioner movement. Check rideout condition by installing a new belt. If excessive accessory drive belt tensioner movement still exists, install a new accessory drive belt tensioner.