

# IN-VEHICLE REPAIR

## Intake Manifold

### Material

| Item                                   | Specification |
|--|---------------|
| Motorcraft Metal Surface Prep<br>ZC-31 | —             |

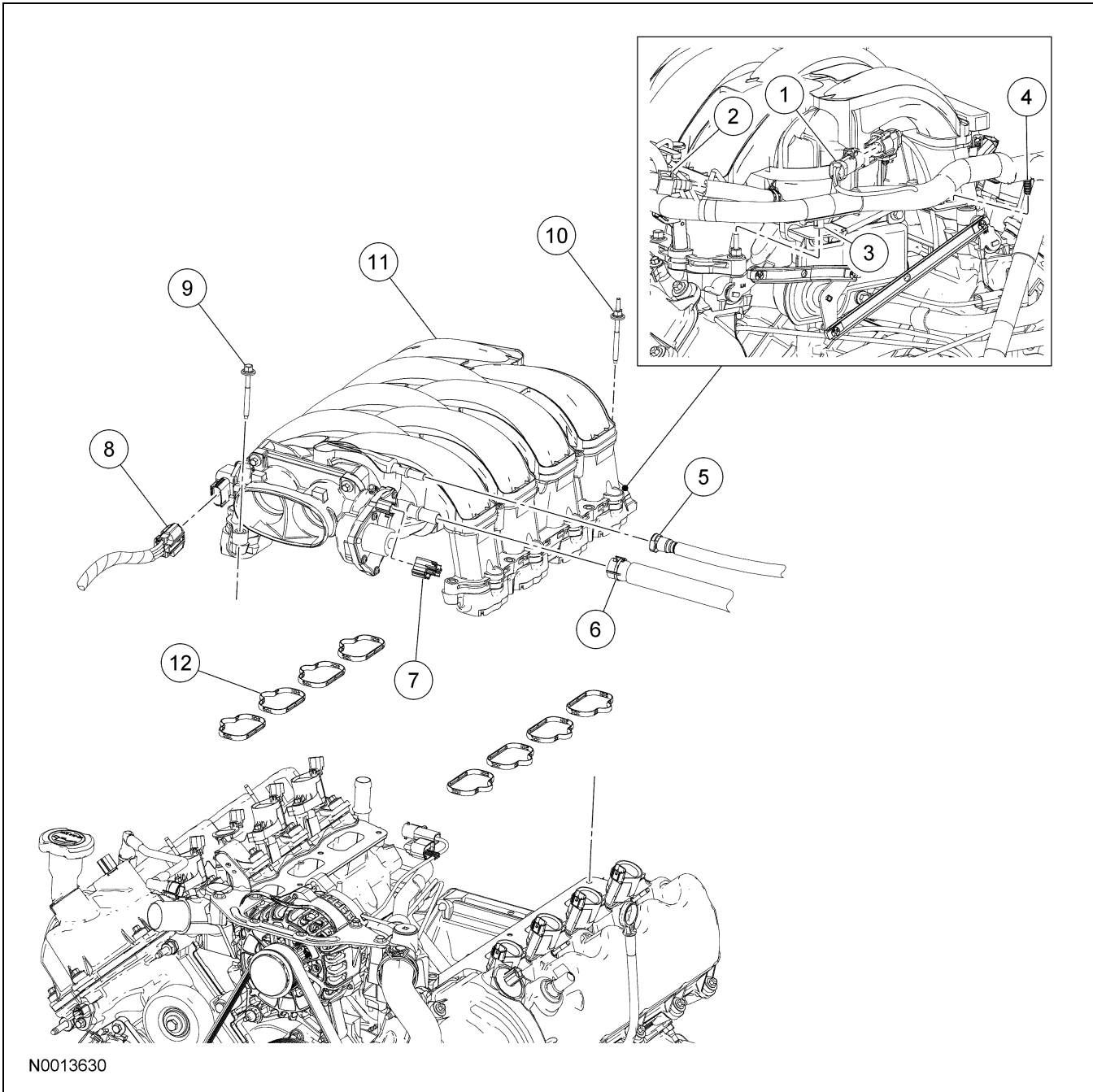

## IN-VEHICLE REPAIR (Continued)

| Item | Part Number | Description  |
|------|-------------|--|
| 1    | 14A464      | Charge motion control valve (CMCV) electrical connector (part of 12B637) |
| 2    | 9F792       | Vacuum hose T-fitting  |
| 3    | —           | Wiring harness retainer (part of 12B637)                                 |
| 4    | —           | Wiring harness pin-type retainer (part of 12B637)                        |
| 5    | 9G271       | Evaporative emissions (EVAP) tube  |
| 6    | 6K817       | Positive crankcase ventilation (PCV) tube                                |
| 7    | 14A464      | Electronic throttle body electrical connector (part of 12B637)           |
| 8    | 14A464      | Throttle position (TP) sensor electrical connector (part of 12B637)      |
| 9    | W709552     | Intake manifold bolt (9 required)  |
| 10   | W710464     | Intake manifold stud bolt  |
| 11   | 9425        | Intake manifold  |
| 12   | 9439        | Intake manifold gasket (8 required)                                      |

## Removal

**⚠ WARNING: Do not smoke or carry lighted tobacco or open flame of any type when working on or near any fuel-related component. Highly flammable mixtures are always present and may be ignited. Failure to follow these instructions may result in personal injury.**

**⚠ WARNING: Fuel in the fuel system remains under high pressure even when the engine is not running. Before servicing or disconnecting any of the fuel lines or fuel system components, the fuel system pressure must be relieved to prevent accidental spraying of fuel, causing personal injury or a fire hazard.**

1. Release the fuel system pressure. For additional information, refer to Section 310-00.
2. Remove the air cleaner outlet pipe. For additional information, refer to Section 303-12.
3. Remove the fuel rail and injectors. For additional information, refer to Section 303-04B.

4. Disconnect the evaporative emissions (EVAP) tube from the intake manifold and position the tube aside.
5. Disconnect the positive crankcase ventilation (PCV) tube from the intake manifold and position the tube aside.
6. Disconnect the throttle position (TP) sensor and electronic throttle body electrical connectors.
7. Disconnect the charge motion control valve (CMCV) electrical connector.
8. Detach the wiring retainers from the intake manifold stud bolt and the CMCV bracket and then position the wiring harness aside.
9. Disconnect the vacuum hose from the T-fitting.
10. **⚠ CAUTION: Do not use metal scrapers, wire brushes, power abrasive discs or other abrasive means to clean the sealing surfaces. These tools cause scratches and gouges which make leak paths. Use a plastic scraping tool to remove all traces of old sealant.**

**NOTE:** Clean and inspect the sealing surfaces with metal surface prep. Follow the directions on the packaging.

Remove the 9 bolts, the stud bolt and the intake manifold.

- Discard the gaskets.

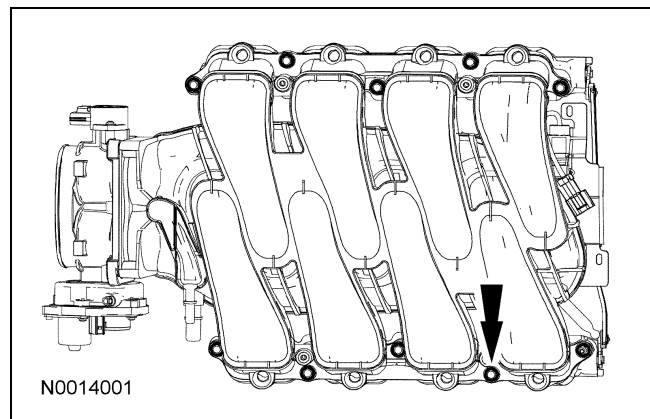

**IN-VEHICLE REPAIR (Continued)****Installation**

1. **NOTE:** Electrical and vacuum harnesses must not restrict movement of the charge motion control valve (CMCV) control rods at rear of the intake manifold. Use extreme care on installation of the intake manifold to prevent any pinching of electrical and vacuum harnesses.

Using new intake manifold gaskets, position the intake manifold.

2. Install the intake manifold bolts and stud bolt.
  - Tighten in the sequence shown to 10 Nm (89 lb-in).

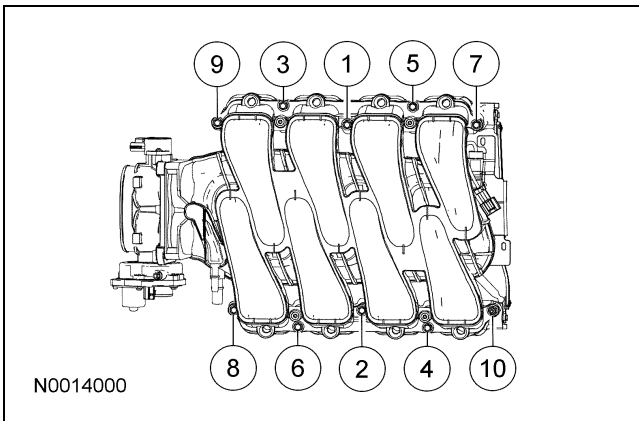

3. Connect the vacuum hose to the T-fitting.
4. Position the wiring harness and attach the wiring retainers to the intake manifold stud bolt and the CMCV bracket.
5. Connect the CMCV electrical connector.
6. Connect the TP sensor and electronic throttle body electrical connectors.
7. Connect the PCV tube to the intake manifold.
8. Connect the EVAP tube to the intake manifold.
9. Install the fuel rail and injectors. For additional information, refer to Section 303-04B.
10. Install the air cleaner outlet pipe. For additional information, refer to Section 303-12.