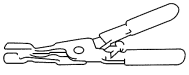
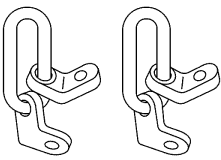
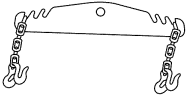

REMOVAL

Engine

Special Tool(s)

 <p>ST1394-A</p>	<p>Remover, Spark Plug Wire 303-106 (T74P-6666A)</p>
 <p>ST1595-A</p>	<p>Lifting Bracket, Engine 303-050 (D70P-6000) or equivalent</p>
 <p>ST1602-A</p>	<p>Spreader Bar 303-D089 (D93P-6001-A3) or equivalent</p>

Removal

All vehicles

1. With the vehicle in NEUTRAL, position it on a hoist. For additional information, refer to Section 100-02.
2. Release the fuel system pressure. For additional information, refer to Section 310-00.
3. Disconnect the battery ground and positive cables. For additional information, refer to Section 414-01.
4. Remove the air cleaner and air cleaner outlet pipe. For additional information, refer to Section 303-12.
5. Release the 2 windshield washer hose retainers and the one hood insulation pin-type retainer.

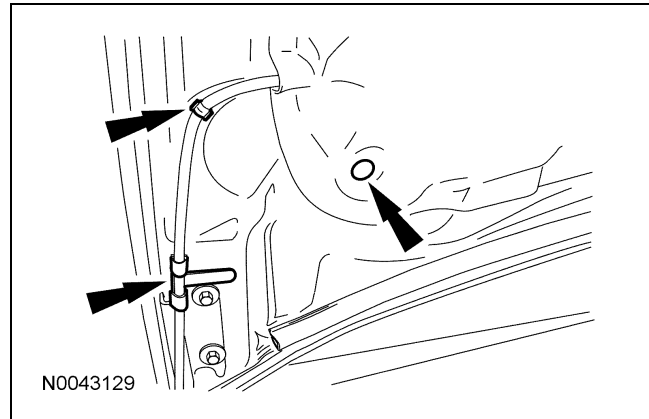

6. Position the hood insulation aside and disconnect the windshield washer hose.

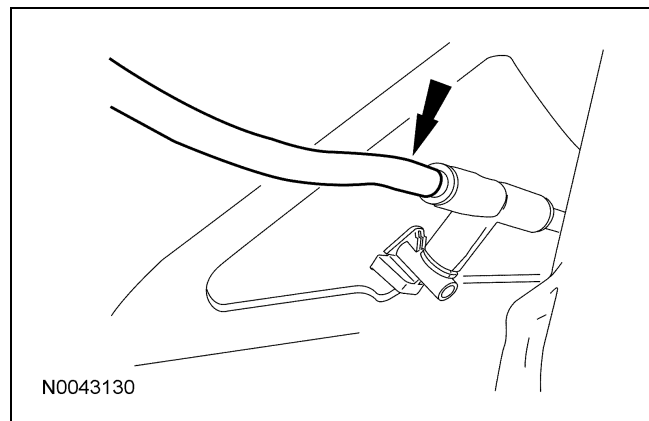

7. **NOTE:** Index-mark the hood hinge location to aid in hood installation.
Remove the 4 bolts and the hood.
8. Drain the cooling system. For additional information, refer to Section 303-00.

Vehicles with automatic transmission

9. Remove the transmission. For additional information, refer to Section 307-01.

Vehicles with manual transmission

10. Remove the clutch. For additional information, refer to Section 308-01.

REMOVAL (Continued)**All vehicles**

11. Disconnect the 2 heated oxygen sensor (HO2S) and the 2 catalyst monitor sensor electrical connectors.

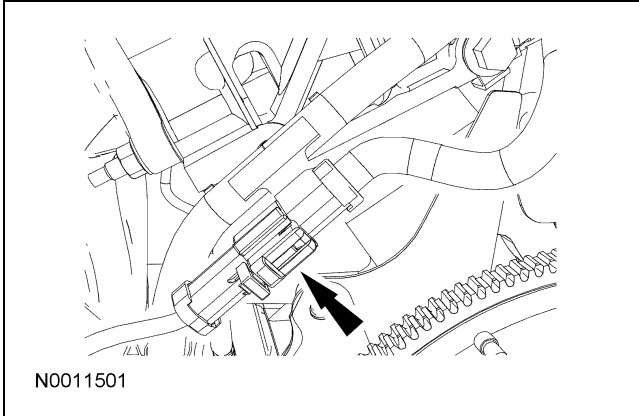

12. **NOTE:** LH side shown, RH side similar.
Remove the 4 catalytic converter-to-exhaust manifold nuts.

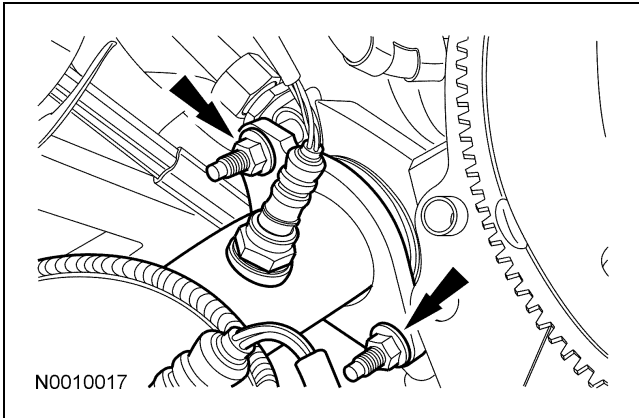

13. Remove the stud bolt and detach the ground strap.
• Position the ground strap aside.

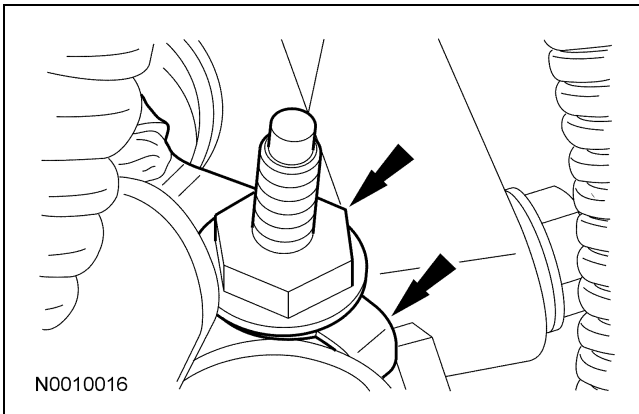

14. Remove the oil pan drain plug and drain the engine oil.
• Install the drain plug and tighten to 26 Nm (19 lb-ft).

15. Disconnect the upper radiator hose from the thermostat housing.

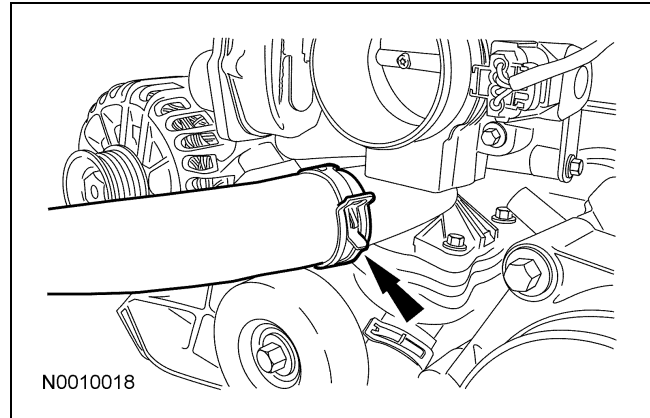

16. Disconnect the lower radiator hose from the coolant pump.

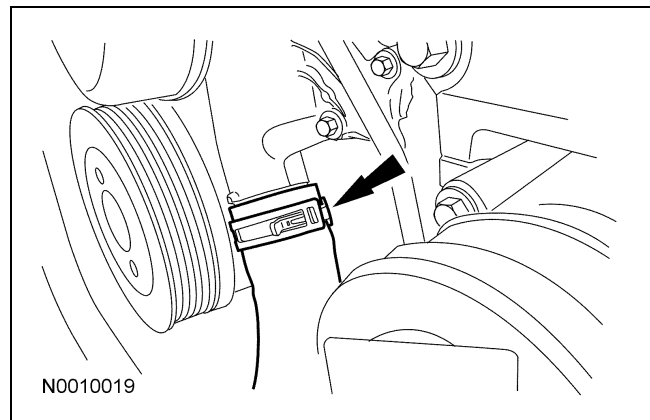

17. Remove the nut and power steering pressure tube bracket from the A/C compressor.

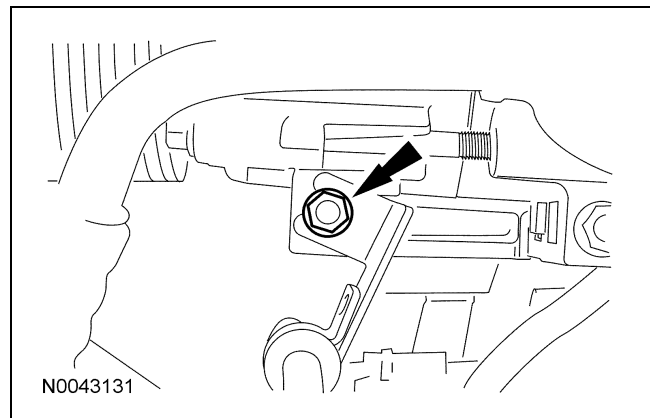

REMOVAL (Continued)

18. Remove the bolt and detach the power steering supply hose bracket from the front engine accessory drive (FEAD) bracket.

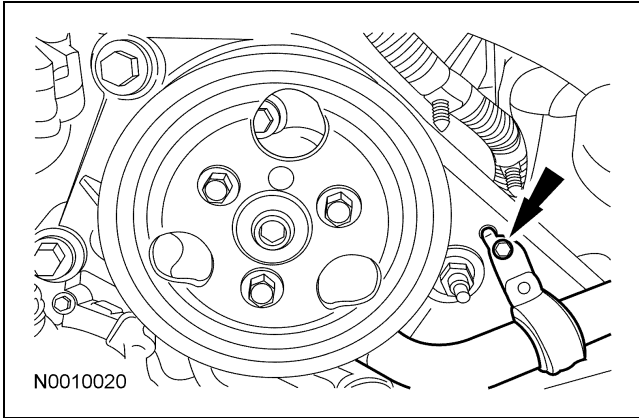

19. Disconnect the PSP switch electrical connector.

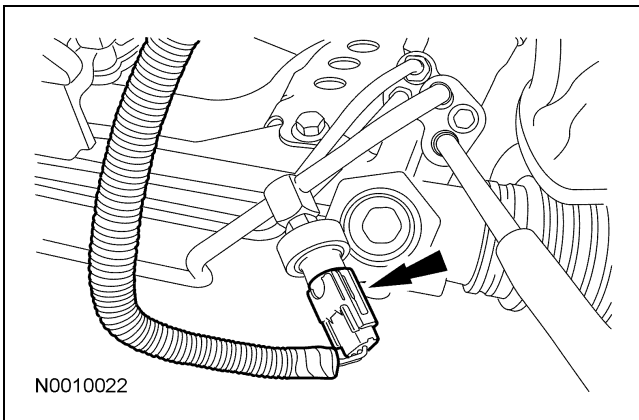

20. Disconnect the A/C compressor and A/C high pressure switch electrical connectors.

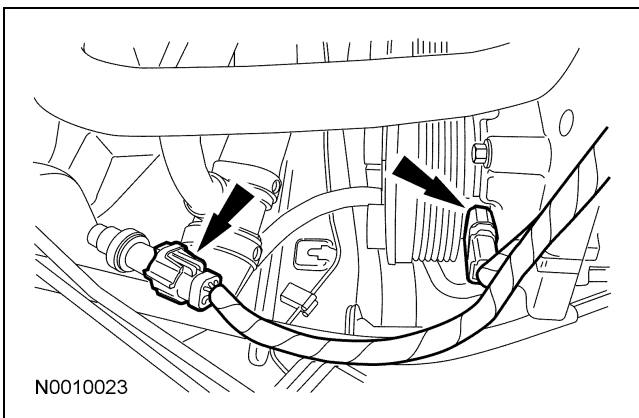

21. Detach the 2 wiring retainers from the FEAD bracket.

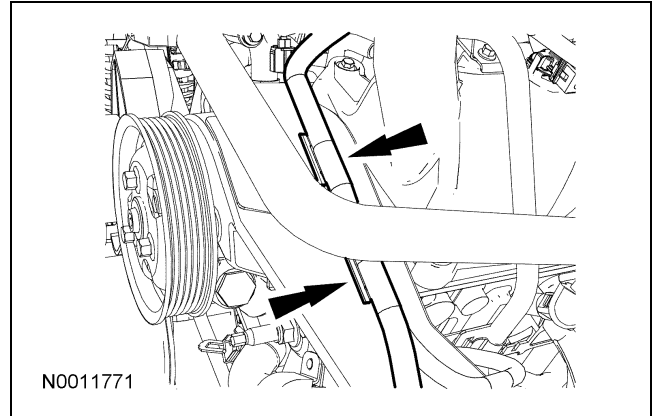

22. Disconnect the fuel supply tube coupling. For additional information, refer to Section 310-00.

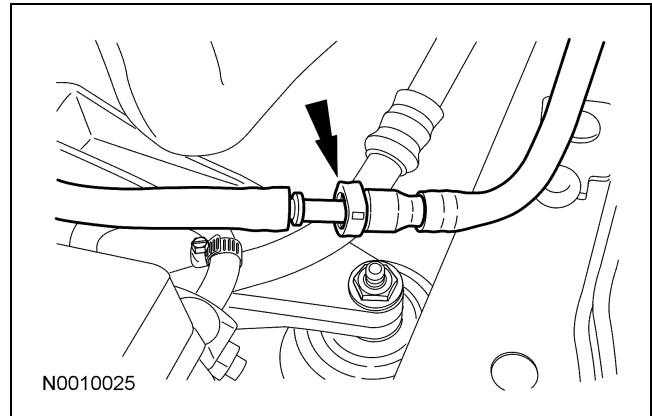

23. Rotate the accessory drive belt tensioner counterclockwise and remove the accessory drive belt.

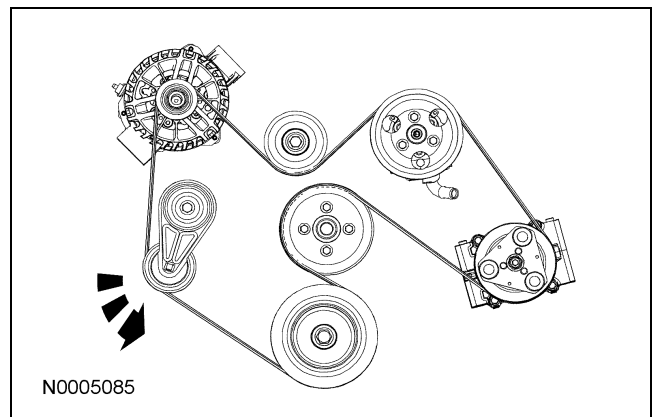

REMOVAL (Continued)

24. Remove the 3 bolts and the power steering pump pulley.

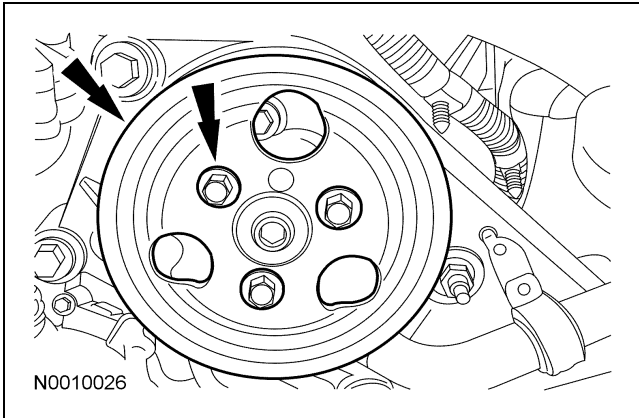

25. Remove the 3 bolts and position the power steering pump aside.

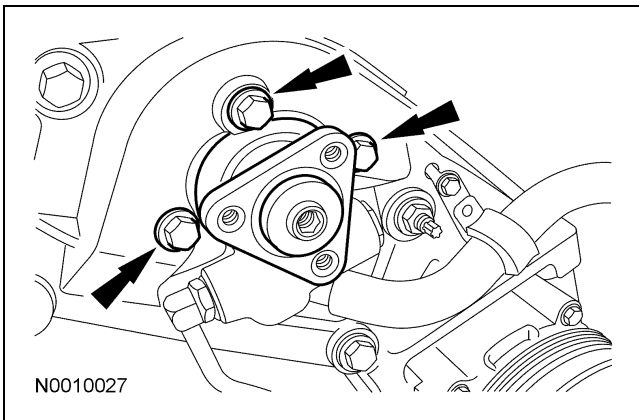

26. Remove the 3 bolts, the nut and position the FEAD bracket and A/C compressor aside.

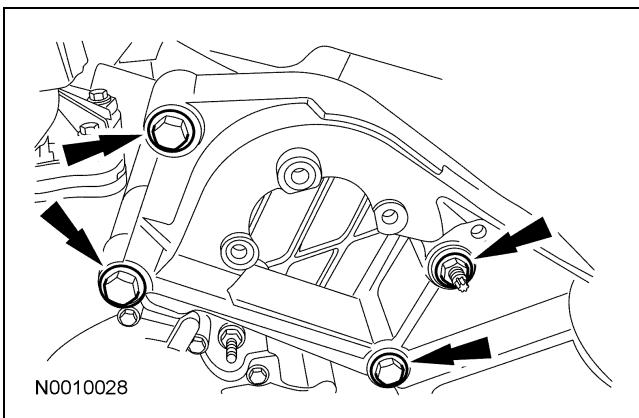

27. Disconnect the 2 heater hoses from the coolant tube.

- Detach the heater hose bracket from the RH valve cover.

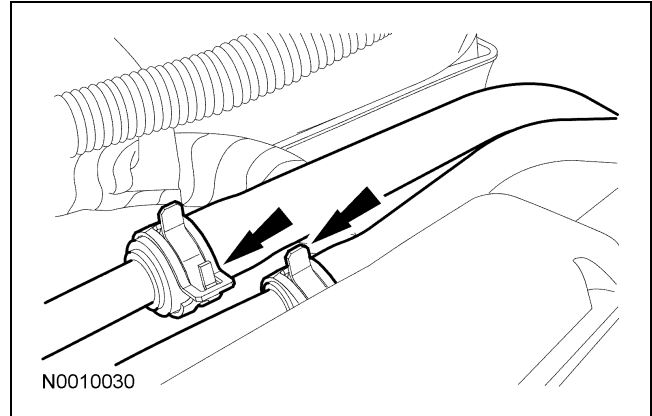

28. Remove the 2 coolant tube bracket bolts.

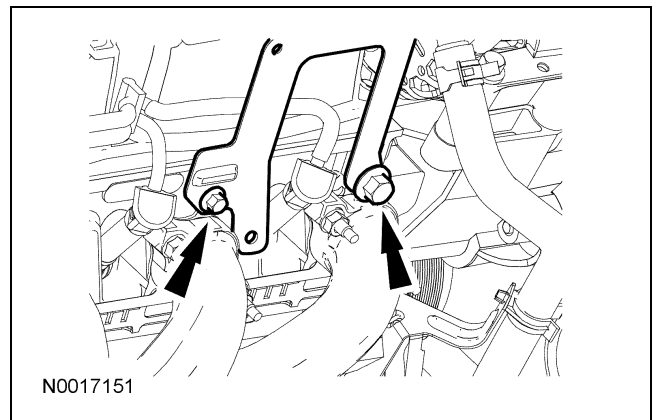

29. **NOTE:** When removing the ignition wires, a slight twisting motion will break the seal and ease removal.

Using the special tool, disconnect the 6 spark plug wires from the spark plugs.

- Detach the retainers from the valve cover stud bolts and the ignition coil bracket.

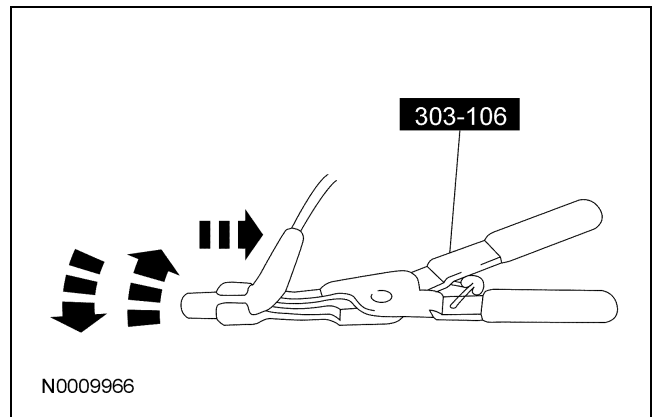

REMOVAL (Continued)

30. Detach the spark plug wire retainer from the intake manifold.

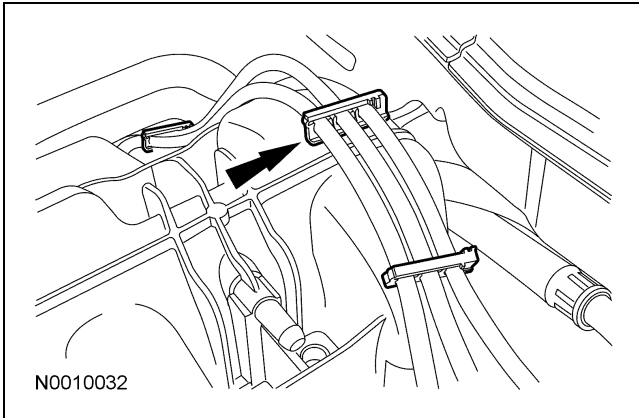

31. Disconnect the radio ignition interference capacitor electrical connector.

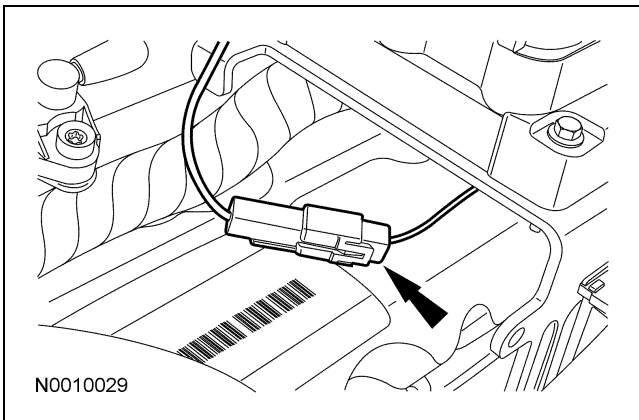

32. Disconnect the ignition coil electrical connector.

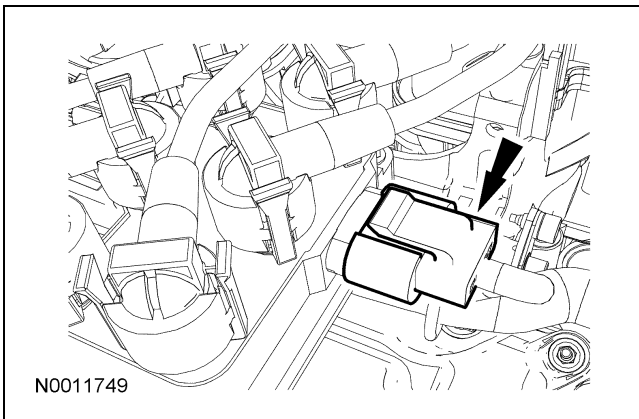

33. Remove the 2 upper ignition coil bracket bolts.

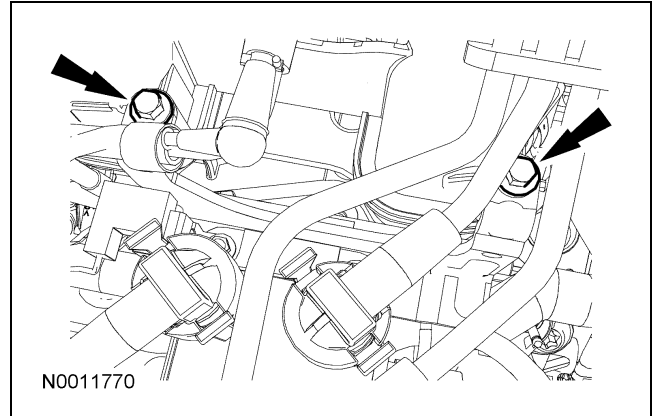

34. Remove the 2 lower ignition coil bracket bolts and then remove the ignition coil and spark plug wires.

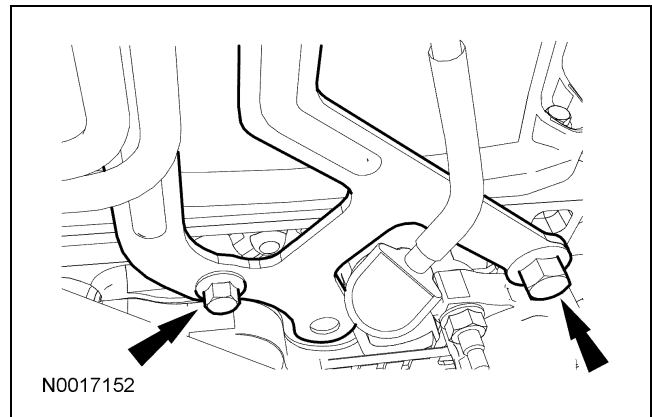

35. Detach the crankcase vent tube from the LH valve cover and remove the tube.

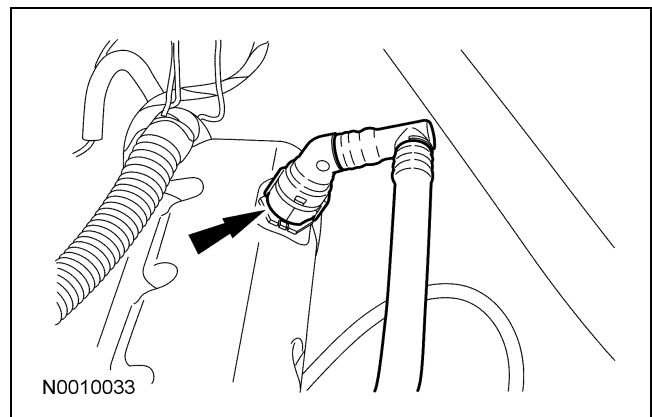

REMOVAL (Continued)

36. Disconnect the brake booster vacuum hose from the upper intake manifold.

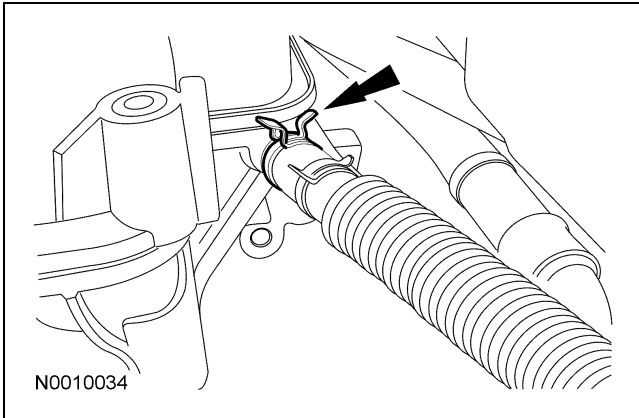

37. Disconnect the fuel vapor vent tube from the intake manifold.

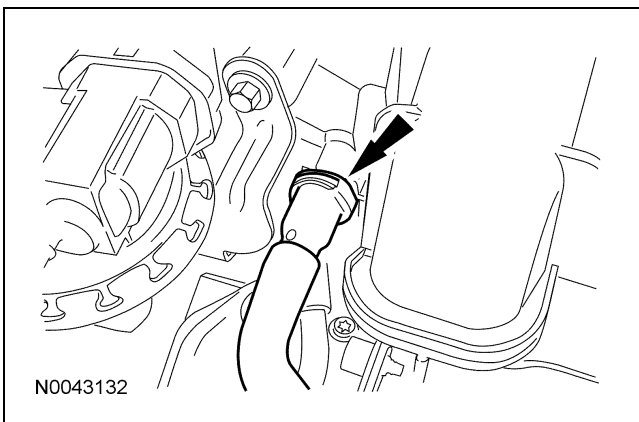

38. Disconnect the upper and lower powertrain control module (PCM) electrical connectors.

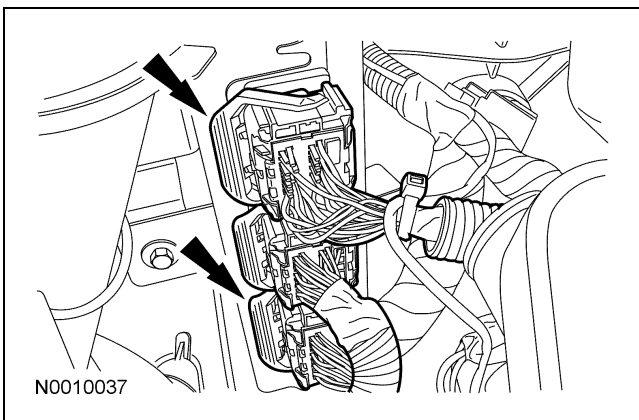

39. Disconnect the 16 pin electrical connector and detach the 2 wiring retainers.

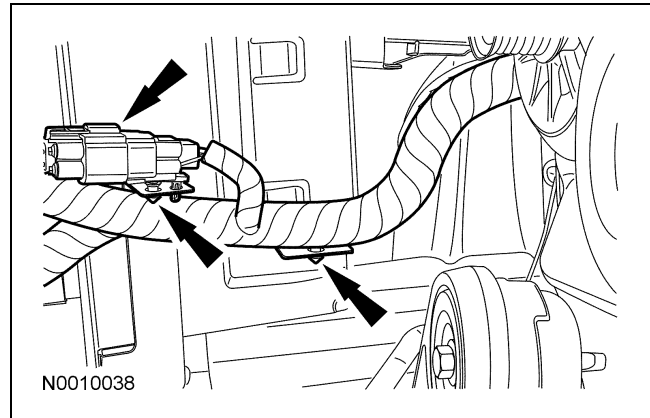

40. Detach the 3 wiring harness retainers.

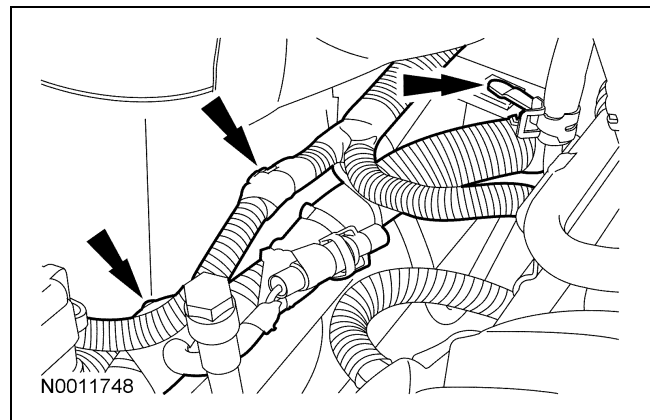

41. Remove the power distribution box cover.

42. Remove the bolt and detach the B+ terminal from the power distribution box.

- Detach the pin-type retainer from the strut tower.

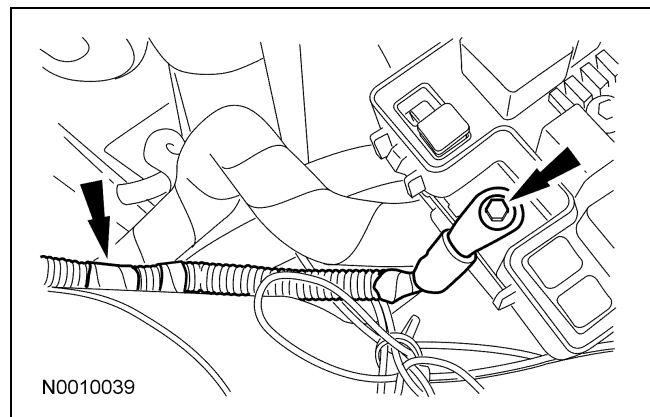

REMOVAL (Continued)

43. Detach the power distribution box upper housing from the lower housing, loosen the bolt and then disconnect the 68-pin connector from the power distribution box.

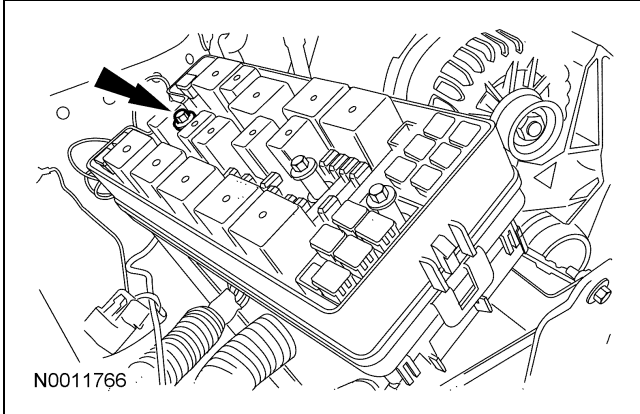

44. Remove the bolt and detach the ground cable from the RH strut tower.

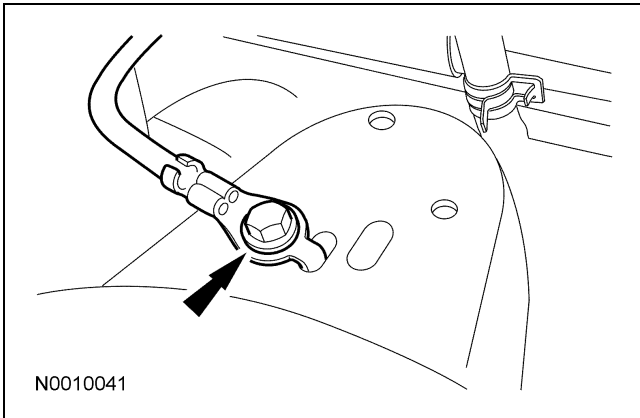

45. Detach the battery cable harness pin-type retainer from the cowl.

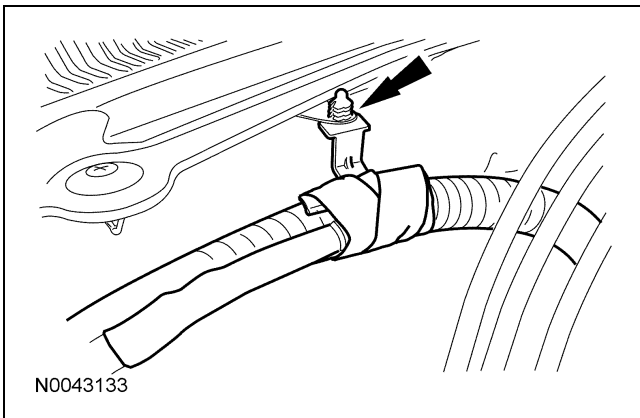

46. Install the special tool to the RH cylinder head.

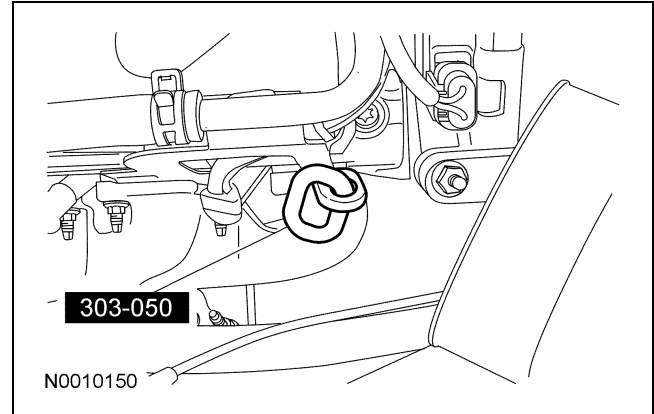

47. Install the special tool to the LH cylinder head.

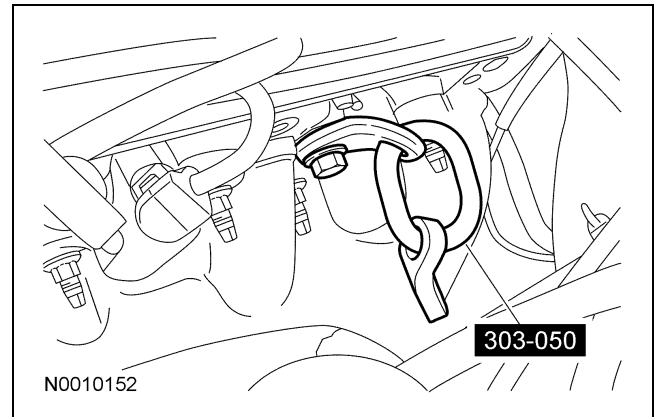

48. Remove the LH engine mount nut.

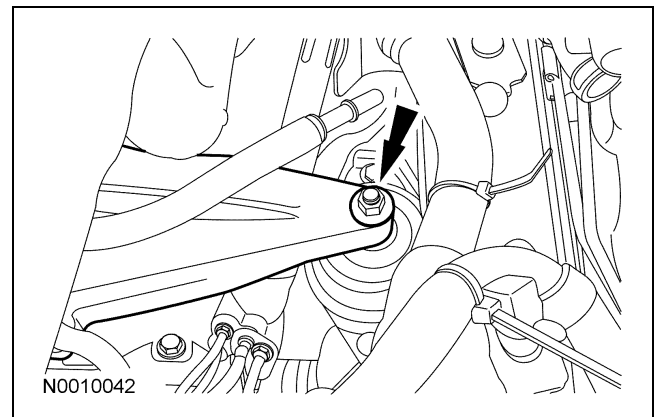

REMOVAL (Continued)

49. Remove the RH engine mount nut.

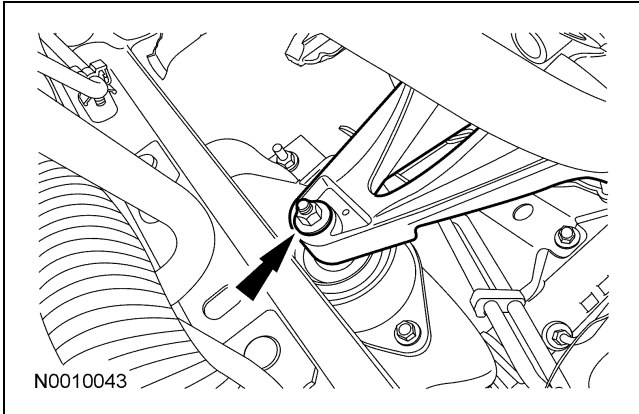

50. Using the special tools, remove the engine.

