

IN-VEHICLE REPAIR

Exhaust Manifold — LH

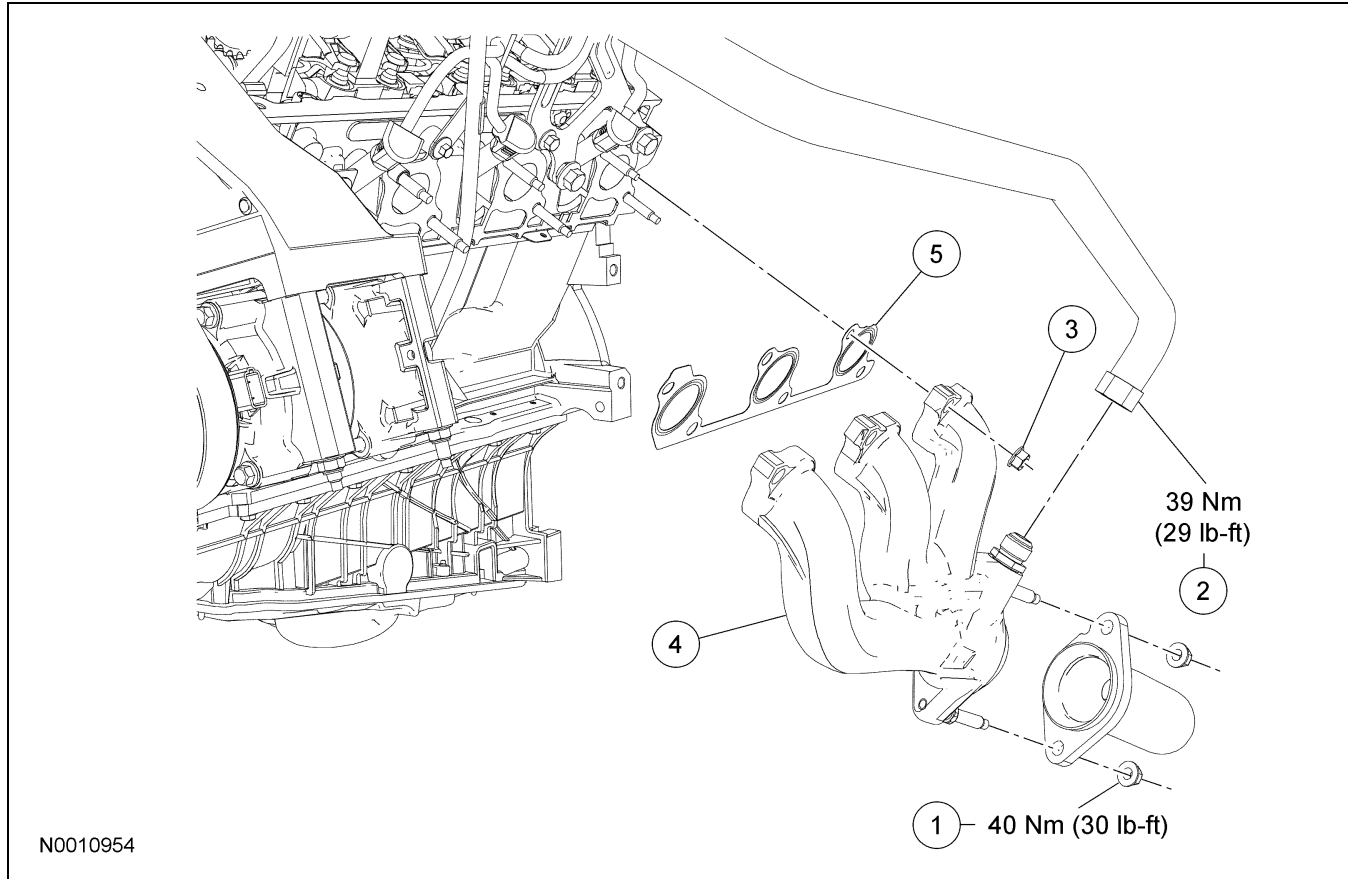

Item	Part Number	Description
1	W701706	LH catalytic converter-to-exhaust manifold nut (2 required)
2	—	Exhaust gas recirculation (EGR) system module tube fitting (part of 9E649)
3	W701706	LH exhaust manifold nut (6 required)
4	9431	LH exhaust manifold
5	9448	LH exhaust manifold gasket

Removal and Installation

1. With the vehicle in NEUTRAL, position it on a hoist. For additional information, refer to Section 100-02.

2. Remove the 2 catalytic converter-to-exhaust manifold nuts.
 - To install, tighten to 40 Nm (30 lb-ft).
3. Disconnect the exhaust gas recirculation (EGR) system module tube from the exhaust manifold.
 - To install, tighten to 39 Nm (29 lb-ft).
4. Remove the 6 nuts, the LH exhaust manifold and the gasket.
 - Remove and discard the gasket.
 - To install, tighten to 23 Nm (17 lb-ft).
5. **NOTE:** Install a new LH exhaust manifold gasket.
To install, reverse the removal procedure.