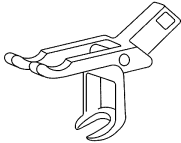

IN-VEHICLE REPAIR

Camshaft Roller Follower

Special Tool(s)

 <p>ST1330-A</p>	<p>Compressor, Valve Spring 303-581 (T97T-6565-A)</p>
---	---

Material

Item	Specification
<p>Motorcraft SAE 5W-30 Premium Synthetic Blend Motor XO-5W30-QSP (in Canada Motorcraft SAE 5W-30 Super Premium Motor Oil CXO-5W30-LSP12) or equivalent</p>	<p>WSS-M2C929-A</p>

Removal and Installation

1. Remove the fuel rail. For additional information, refer to Section 303-04A.
2. Remove the LH and RH valve covers. For additional information, refer to Valve Cover — RH and Valve Cover — LH in this section.
3. Rotate the crankshaft until the camshaft for the cylinder being serviced is at base circle.

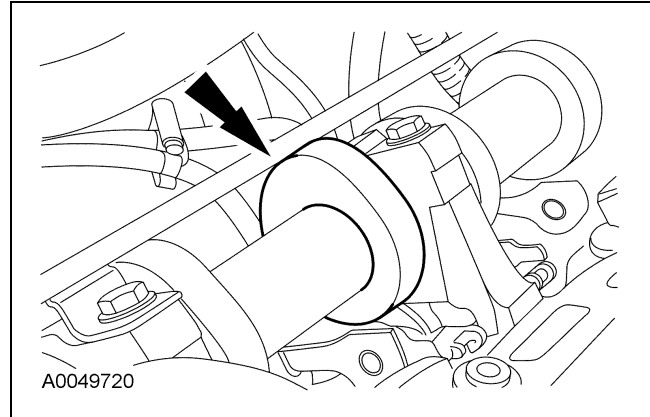

4. **NOTE:** Mark the position of the camshaft roller followers so they can be installed in their original positions.
Using the special tool, remove the camshaft roller followers.

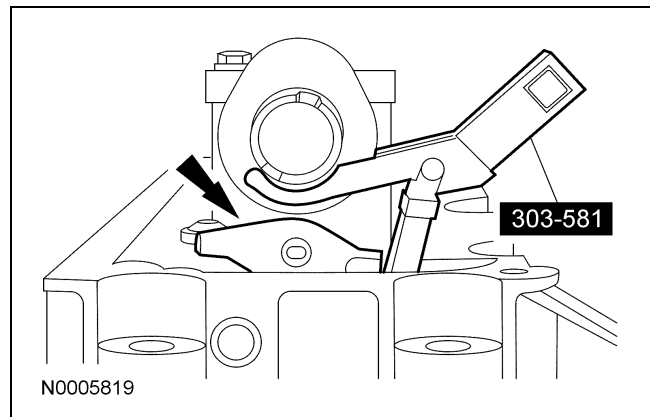

5. **NOTE:** The camshaft roller followers must be installed in their original positions.
NOTE: Lubricate the camshaft roller followers with clean engine oil.
To install, reverse the removal procedure.