

GENERAL PROCEDURES

Headlamp Adjustment

Headlamp Aiming

- The headlamp aiming procedure depends on the type of beam pattern the headlamp is equipped with. Vehicles may come equipped with visual optical right (VOR), visual optical left (VOL), or SAE only (includes sealed beam-type) headlamps. To identify the headlamp beam pattern, look on the headlamp lens. Molded in small letters on the headlamp lens is one of the following:
 - SAE
 - VOR or SAE
 - VOL or SAE
- Once the headlamp beam pattern is identified, aim the headlamps using one of the following methods as applicable.
 - Photometric aimers can aim SAE-, VOR- and VOL- type headlamps. This is the preferred method of headlamp aiming.
 - Visual or screen method aiming can be used to aim SAE-, VOR- and VOL-type headlamps.
 - Mechanical aimers can be used only with SAE-type headlamps. Lamps that can be aimed mechanically will have three nibs molded into the lens of the lamp.

Photometric Aiming

- For the photometric aiming procedure, refer to the appropriate photometric headlamp aimer instruction manual.

Screen Method Aiming

All headlamp types

NOTE: Horizontal aim is not necessary for VOR or VOL headlamps.

NOTE: Consult your state vehicle inspection manual for recommended tolerance ranges for visual aiming.

NOTE: The sight shield may need to be positioned or removed for access to the adjusters.

- Before starting headlamp adjustment:
 - Check the tire inflation.
 - Check that no other load is in the vehicle other than a half tank of fuel.
 - Check that the headlamps are clean.
 - Check for correct headlamp operation.
 - Check that the vehicle is on level ground.
 - If the vehicle is equipped with air suspension, make sure that the switch is on.

- NOTE:** The vertical wall or screen must be a minimum of 2.4-meters (8-feet) wide.

Park the vehicle on a level surface approximately 7.6 meters (25 feet) from the vertical wall or screen directly in front of it.

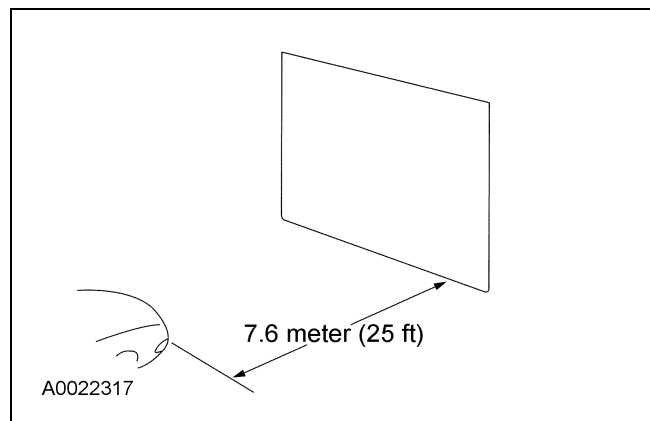

GENERAL PROCEDURES (Continued)

3. **NOTE:** The center of the lamp is marked either on the lens (circle, crosshair or other mark) or on the bulb shield internal to the lamp (crosshair or other mark).

Mark a horizontal reference line on the vertical wall or screen.

- 1 Measure the center of the headlamp height to ground and record.
- 2 Make a 2.4-meter (8-foot) horizontal mark (masking tape) on the vertical wall or screen at the same distance from the ground as previously recorded.

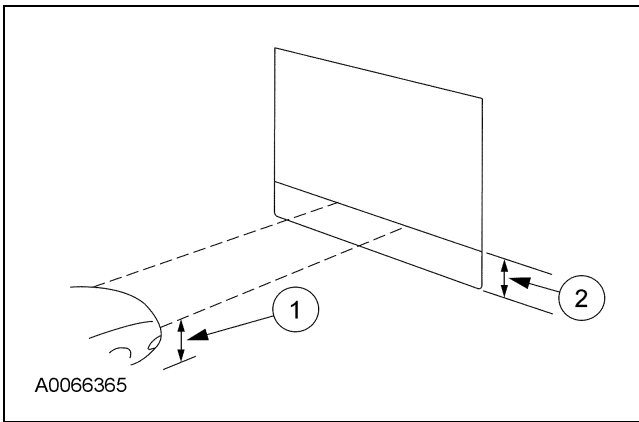

4. **NOTE:** This procedure should be done in a dark environment to effectively see the headlamp beam pattern.
- Turn on the low beam headlamps to illuminate the wall or screen and open the hood.

5. **NOTE:** For SAE type headlamps, the appearance of the beam pattern may vary between vehicles.

On the wall or screen, locate the high intensity area of the beam pattern. Place the top edge of the high intensity zone even with the horizontal reference line.

VOR-type headlamps

6. **NOTE:** The appearance of the VOR beam pattern may vary between vehicles.

Identify at the top edge of this high intensity area a distinct horizontal cutoff in the beam pattern. If the top edge of this cutoff is not even with the horizontal reference line, the headlamp beam will need to be adjusted.

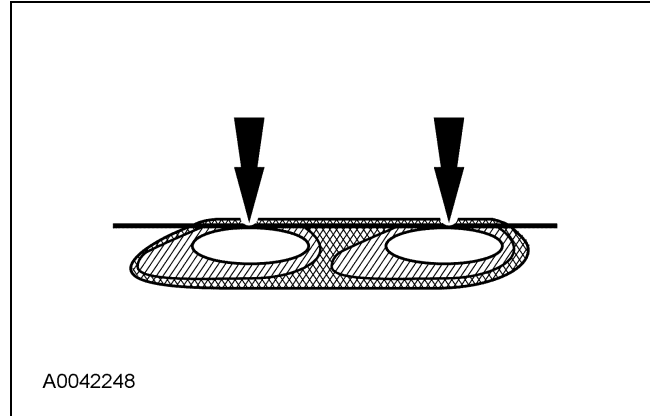

VOL-type headlamps

7. For VOL-type headlamps, there will be a distinct cutoff in the left portion of the beam pattern. The edge of this cutoff should be positioned 50.2 mm (2 in) below the horizontal reference line.

- 1 Horizontal reference line.
- 2 Top edge of the beam pattern.
- 3 High intensity zone.

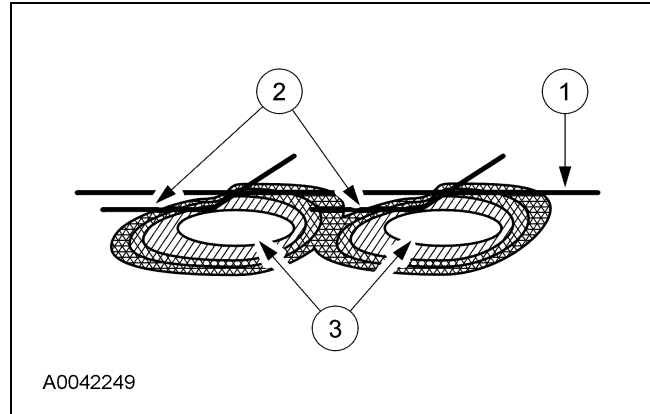

GENERAL PROCEDURES (Continued)**Mechanical Aiming**

1. For the mechanical aiming procedure, refer to the appropriate mechanical headlamp aimer instruction manual.
-