

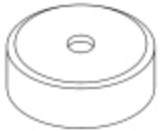





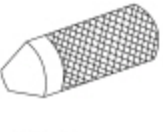

### Differential Ring And Pinion

#### Special Tool(s)

 ST2026-A	2 Jaw Puller <a href="#">205-D072</a> (D79L-4221-A1) or equivalent
 ST1743-A	Adapter for 205-S127 <a href="#">205-105</a> (T76P-4020-A3)
 ST1429-A	Adapter for 205-S127 <a href="#">205-109</a> (T76P-4020-A9)
 ST1431-A	Adapter for 205-S127 <a href="#">205-110</a> (T76P-4020-A10)
 ST1432-A	Adapter for 205-S127 <a href="#">205-111</a> (T76P-4020-A11)
 ST1743-A	Adapter for 205-S127 <a href="#">205-129</a> (T79P-4020-A18)
 ST1434-A	Adapter for 205-S127 <a href="#">205-130</a> (T79P-4020-A19)
 ST1375-A	Installer, Differential Side Bearing <a href="#">205-010</a> (T57L-4221-A2)

 <p>ST1678-A</p>	<p>Installer, Drive Pinion Bearing Cup  <a href="#">205-024</a> (T67P-4616-A)</p>
 <p>ST1367-A</p>	<p>Installer, Shaft Bearing Cone  <a href="#">308-169</a> (T88T-7025-B)</p>
 <p>ST1254-A</p>	<p>Plate, Bearing Oil Seal  205-090 (T75L-1165-B)</p>
 <p>ST1744-A</p>	<p>Protector, Drive Pinion Thread  <a href="#">205-460</a> or equivalent</p>
 <p>ST1543-A</p>	<p>Step Plate  <a href="#">205-D016</a> (D80L-630-5) or equivalent</p>

**Material**

Item	Specification
Maximum Strength Retaining Compound Loctite® 638™	—

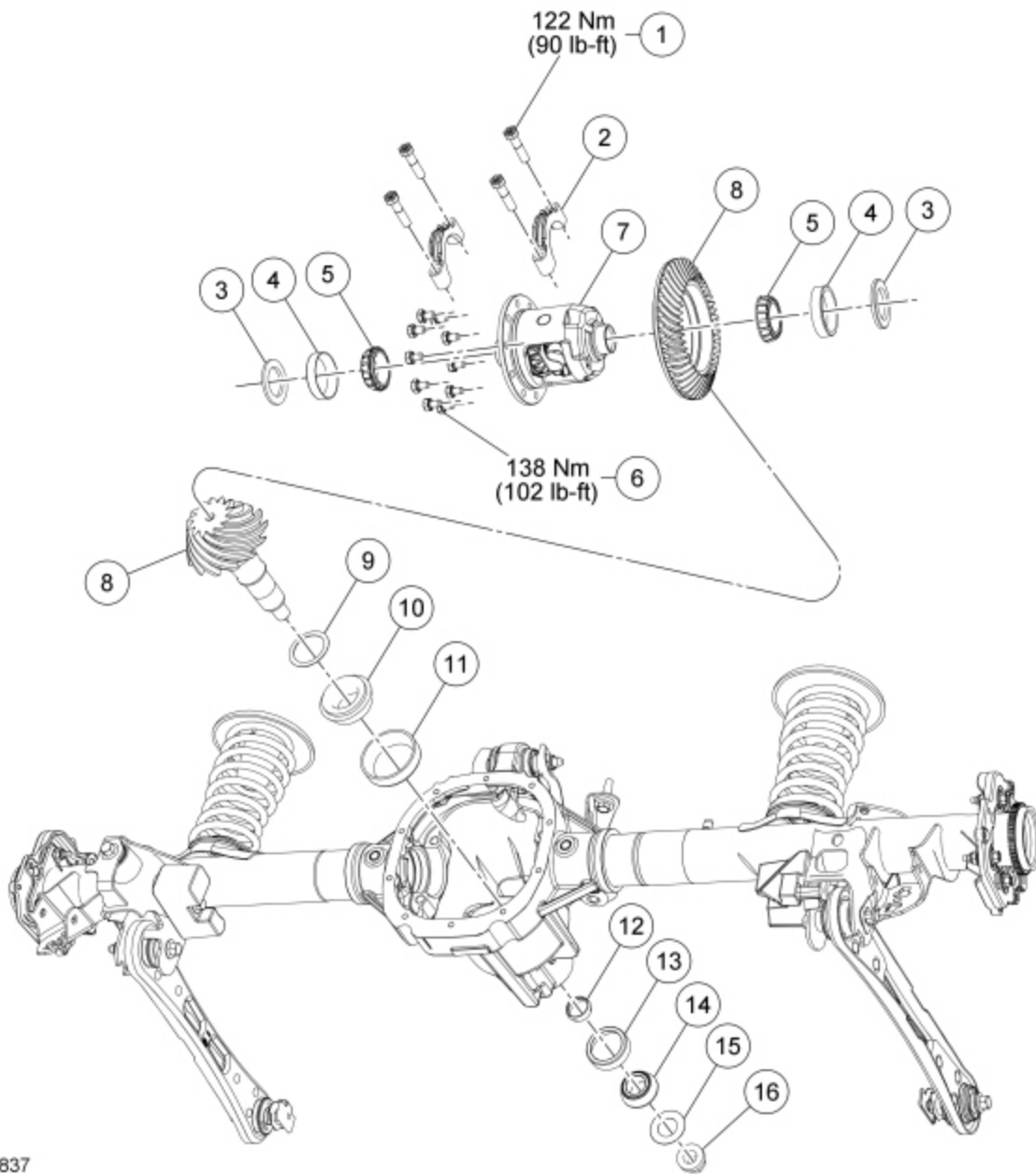

N0116837

Item	Part Number	Description
1	—	Differential bearing cap bolt (part of 4010)
2	—	Differential bearing cap (part of 4010)
3	4067	Differential bearing shims (2 required)
4	4221	Differential bearing cups (2 required)
5	4222	Differential bearing cones (2 required)
6	4216	Differential ring gear bolt (10 required)
7	—	Differential carrier assembly
8	4209	Ring gear (set with drive pinion)
9	4663	Pinion bearing adjustment shim
10	4630	Inner pinion bearing
11	4628	Inner pinion bearing cup
12	4662	Collapsible spacer
13	4616	Outer pinion bearing cup
14	4621	Outer pinion bearing

15	4670	Pinion oil slinger
16	4320	Pinion nut

## Removal

1. Remove the drive pinion flange seal. For additional information, refer to [Drive Pinion Flange and Drive Pinion Seal](#) in this section.
2. Remove the differential carrier. For additional information, refer to [Differential Carrier](#) in this section.
3. Remove and discard the 10 differential ring gear bolts.

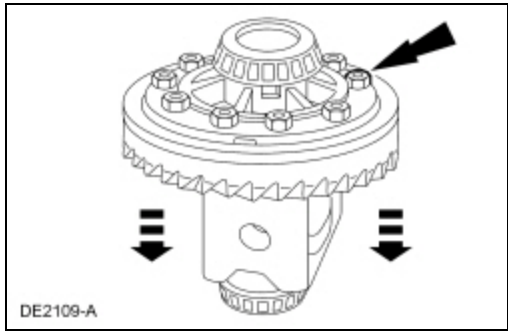

4. **NOTE:** Do not damage the differential ring gear bolt hole threads.

Insert a punch in the differential ring gear bolt holes and drive the differential ring gear off.

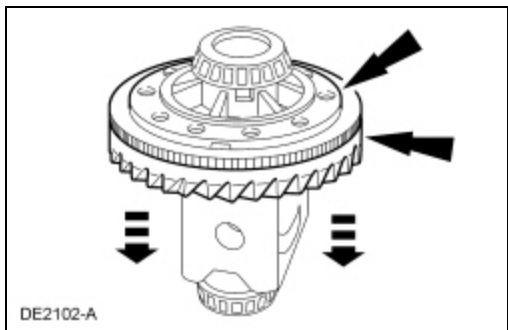

5. **NOTE:** The differential flange and ring gear flange must be free of any old retaining compound material. Failure to clean the surfaces can result in ring gear runout concerns.

Clean all traces of the old retaining compound material from the differential flange.

- Use solvent and Scotch-Brite® pads to remove.

6. Using the 2 Jaw Puller and Step Plate, remove the 2 differential bearings.

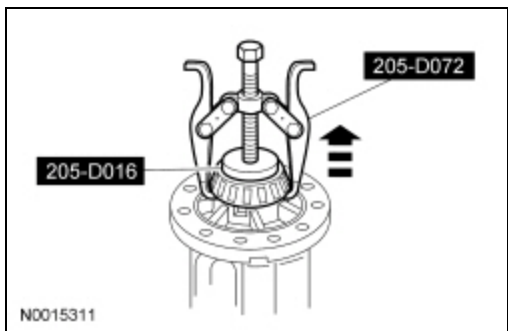

7. Remove the drive pinion shaft oil slinger and the outer drive pinion bearing.
8. Install the Drive Pinion Thread Protector. Using a soft-faced hammer, drive the pinion assembly out of the axle housing.

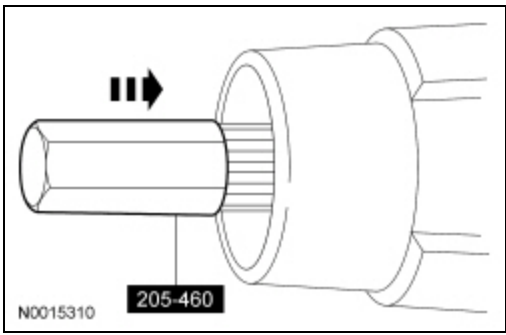

9. Remove and discard the drive pinion collapsible spacer.

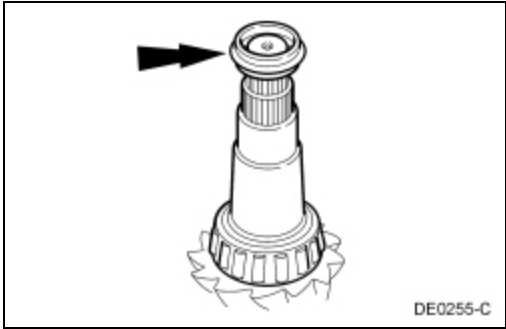

10. Using a brass drift, remove the drive pinion bearing cups by tapping alternately on opposite sides of the drive pinion bearing cups.

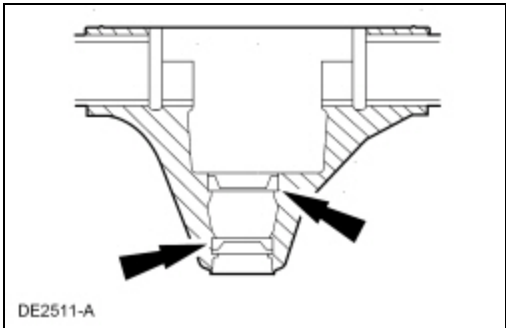

## Installation

1. Position the Drive Pinion Bearing Cup Installer and the inner and outer drive pinion bearing cups in their respective bores.
  1. After placing the inner and outer drive pinion bearing cups in their bores, place the Drive Pinion Bearing Cup Installer (inner) on the inner drive pinion bearing cup.
  2. Place the Drive Pinion Bearing Cup Installer (outer) on the outer drive pinion bearing cup.
  3. Install the Drive Pinion Bearing Cup Installer.

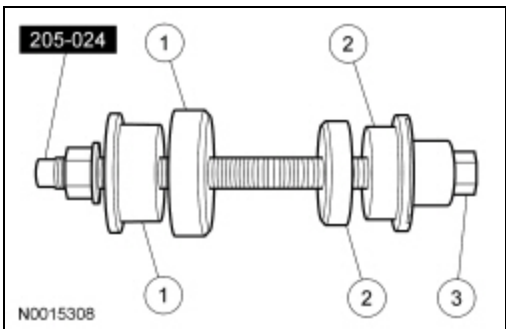

2. Tighten the Drive Pinion Bearing Cup Installer to seat the drive pinion bearing cups into their bores.

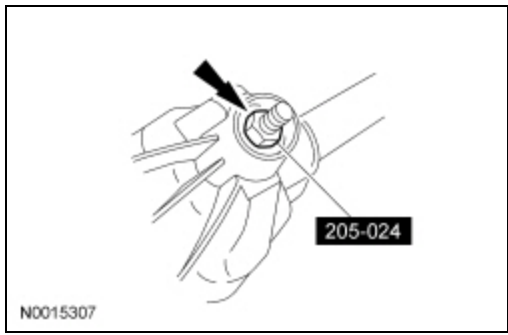

3. **NOTE:** If a feeler gauge can be inserted between a drive pinion bearing cup and the bottom of its bore at any point around the drive pinion bearing cup, the drive pinion bearing cup is not correctly seated.

Make sure the drive pinion bearing cups are correctly seated in their bores.

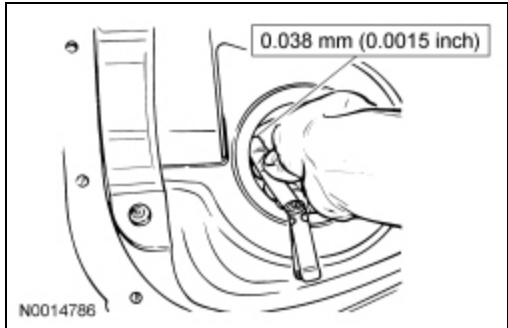

4. **NOTE:** Install new drive pinion bearings without any additional lubricant since the anti-rust oil provides adequate lubricant without upsetting the drive pinion bearing preload settings.

Assemble and position the Adapters for 205-S127.

Item	Part Number	Description
1	205-105	Adapter for 205-S127 (1.612 inch OD) (T76P-4020-A3)
2	205-111	Adapter for 205-S127 (T76P-4020-A11)
3	4621	Drive pinion bearing (outer)
4	205-109	Adapter for 205-S127 (T76P-4020-A9)
5	4630	Drive pinion bearing (inner)
6	205-129	Adapter for 205-S127 (1.1884 inch thick) (T79P-4020-A18)
7	205-110	Adapter for 205-S127 (1.7 inch thick) (T76P-4020-A10)

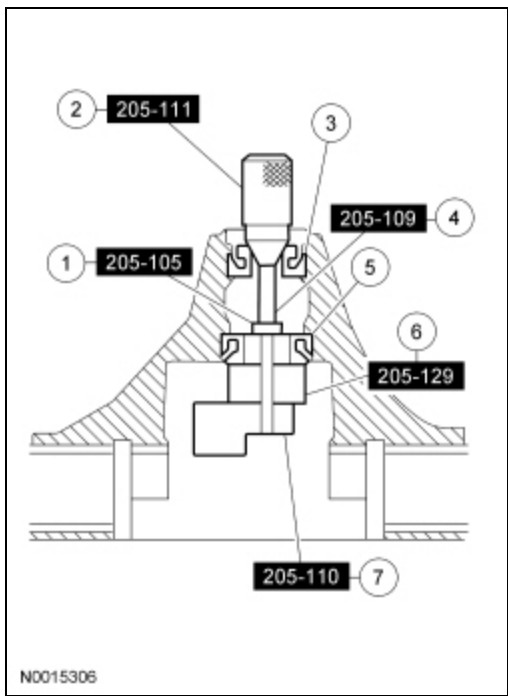

5. **NOTE:** This step duplicates final drive pinion bearing preload.

Tighten the Adapter.

- Tighten to 2.2 Nm (20 lb-in).

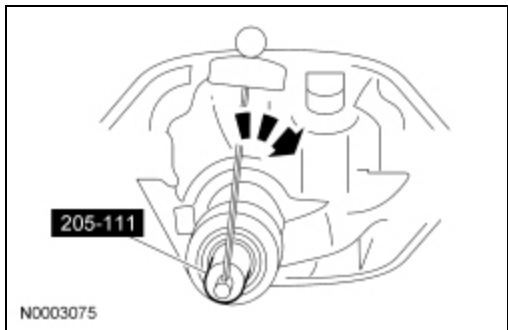

6. **NOTE:** The Adapter must be offset to obtain an accurate reading.

Rotate the Adapter several half-turns to make sure of correct seating of the drive pinion bearings.

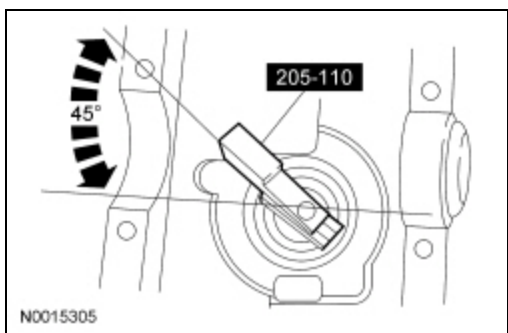

7. Install the Adapter.

1. Position the Adapter.
2. Install the 2 differential bearing caps.
3. Install the 4 differential bearing cap bolts.
  - Tighten to 122 Nm (90 lb-ft).

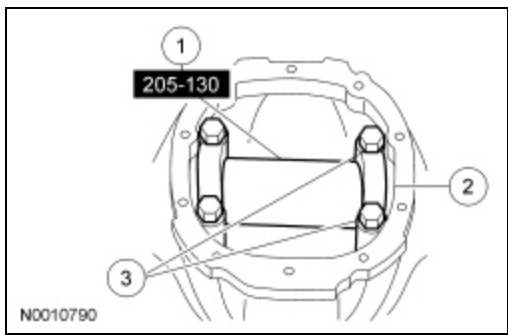

8. **NOTE:** Drive pinion bearing adjustment shims must be flat and clean.

**NOTE:** A slight drag should be felt for correct drive pinion bearing adjustment shim selection. Do not attempt to force the drive pinion bearing adjustment shim between the gauge block and the gauge tube. This will minimize selection of a drive pinion bearing adjustment shim thicker than required, which results in a deep tooth contact in final assembly of integral axle assemblies.

Use a drive pinion bearing adjustment shim as a gauge for drive pinion bearing adjustment shim selection.

- After the correct drive pinion bearing adjustment shim thickness has been determined, remove all of the Adapters.

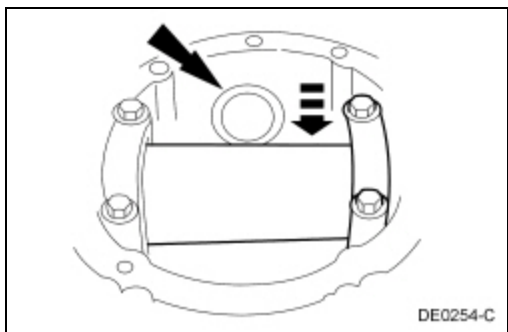

9. Using the Shaft Bearing Cone Installer and Bearing Oil Seal Plate with a shop press, drive the inner drive pinion bearing and the selected drive pinion bearing adjustment shim until they are firmly seated on the pinion shaft.

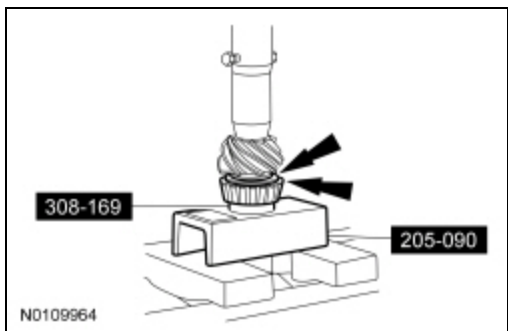

10. Install a new drive pinion collapsible spacer on the pinion shaft against the pinion shaft shoulder.

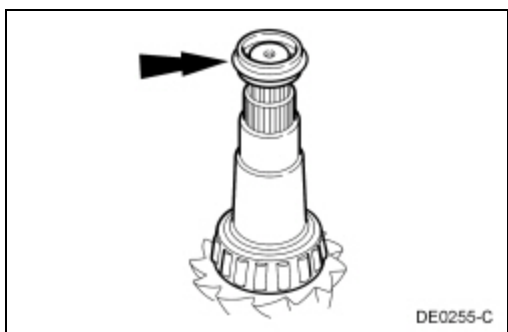

11. Install the drive pinion assembly into the axle housing.

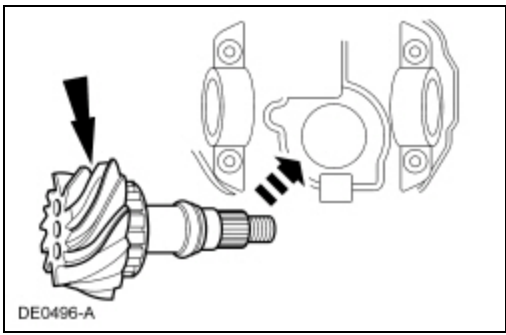

12. Install the outer drive pinion bearing and the drive pinion shaft oil slinger.

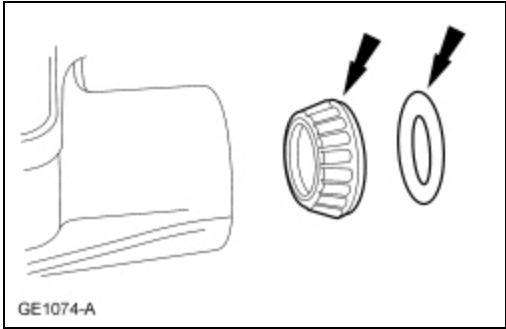

13. Using the Differential Side Bearing Installer, install the 2 new differential bearings.

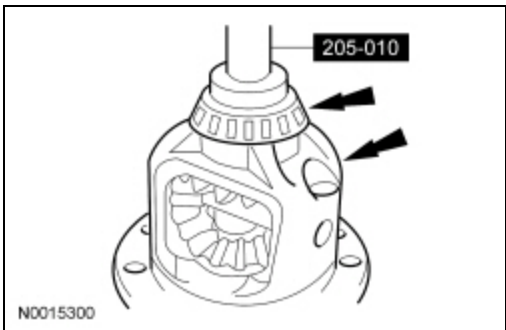

14. Apply a one-eighth inch bead of maximum strength retaining compound on the rear face of the ring in the pattern shown.

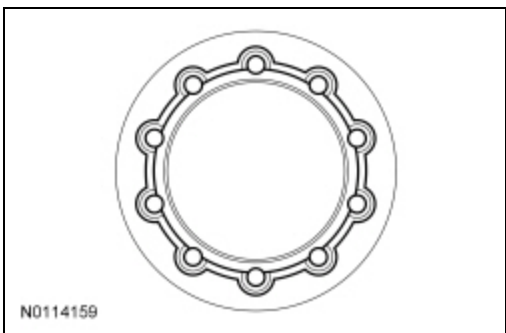

15. Using 2 ring gear bolts as a guide, press the ring gear on the differential assembly.

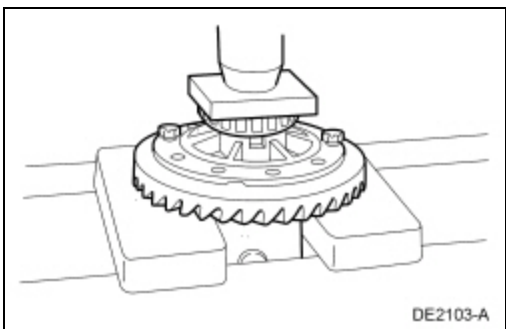

16. Install the 10 new differential ring gear bolts.
- Tighten to 138 Nm (102 lb-ft).

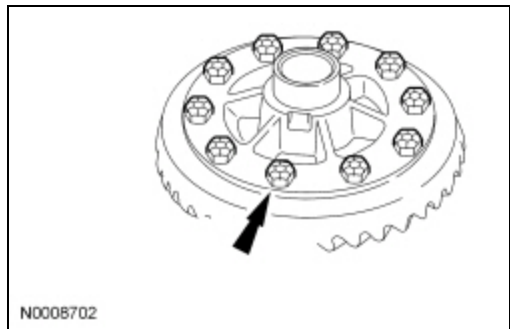

17. Install the drive pinion seal and flange. For additional information, refer to [Drive Pinion Flange and Drive Pinion Seal](#) in this section.

18. Install the differential carrier. For additional information, refer to [Differential Carrier](#) in this section.