





Rear Wheel Bearing and Axle Shaft Seal

Special Tool(s)

 ST1326-A	Adapter for 303-224 205-153 (T80T-4000-W)
 ST1541A	Installer, Axle Shaft Bearing 205-124 (T78P-1225-A)
 ST2027-A	Installer, Rear Axle Oil Seal 205-390 (T97T-1177-B)
 ST2035-A	Remover, Axle Bearing 205-219 (T85L-1225-AH)
 ST1185-A	Slide Hammer 100-001 (T50T-100-A)

Material

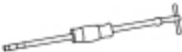
Item	Specification
Motorcraft® SAE 75W-140 Synthetic Rear Axle Lubricant XY-75W140-QL (US); CXY-75W140-1L (Canada)	WSL-M2C192-A and GL-5
Motorcraft® SAE 75W-85 Premium Synthetic Hypoid Gear Lubricant XY-75W85-QL	WSS-M2C942-A
Motorcraft® Premium Long-Life Grease XG-1-E1	ESA-M1C75-B

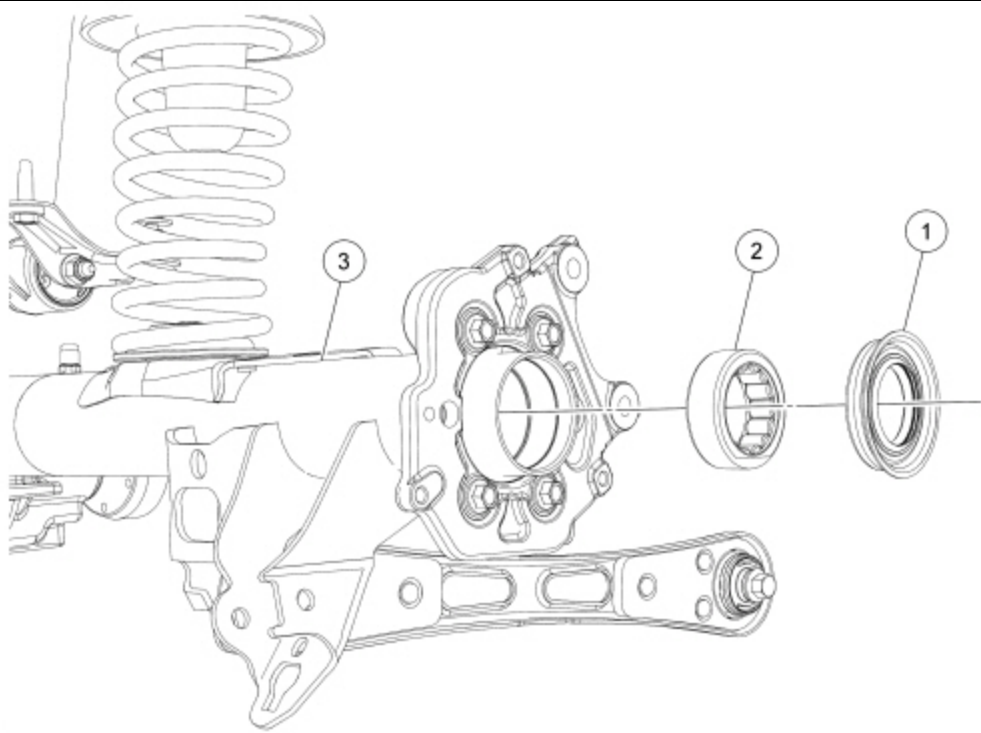

N0071952

Item	Part Number	Description
1	1177	Axle shaft oil seal
2	1225	Rear axle wheel bearing
3	4010	Axle housing

Removal

1. Remove the axle shaft. Refer to [Axle Shaft](#) in this section.
2. **NOTE:** *If the axle shaft oil seal is leaking, the axle housing vent may be plugged.*

Using the Slide Hammer and Axle Bearing Remover, remove the rear wheel bearing and axle shaft oil seal.

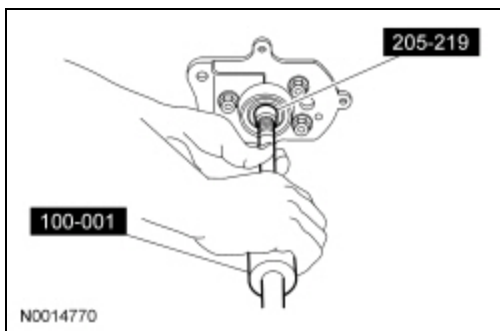

N0014770

Installation

1. Lubricate the new rear wheel bearing with the axle lubricant.
2. Using the Axle Shaft Bearing Installer and Adapter, install the new rear wheel bearing.

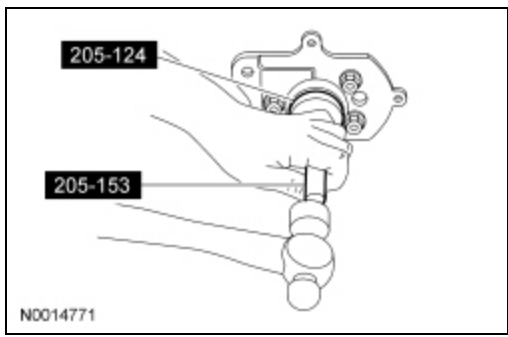

3. Lubricate the lip of the new axle shaft oil seal with grease.
4. Using the Rear Axle Oil Seal Installer and Adapter, install the new axle shaft oil seal.

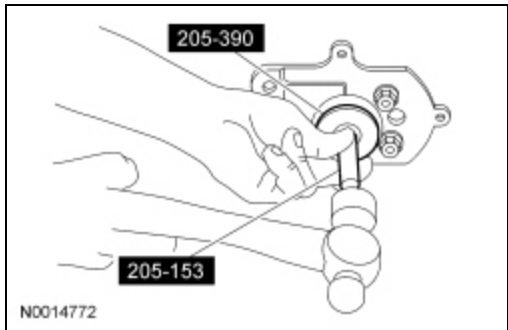

5. Install the axle shaft. Refer to [Axle Shaft](#) in this section.