

Differential Housing Cover

Material

Item	Specification
Motorcraft® Additive Friction Modifier XL-3 (US); CXL-3 (Canada)	EST-M2C118-A
Motorcraft® SAE 75W-140 Synthetic Rear Axle Lubricant XY-75W140-QL (US); CXY-75W140-1L (Canada)	WSL-M2C192-A and GL-5
Motorcraft® SAE 75W-85 Premium Synthetic Hypoid Gear Lubricant XY-75W85-QL	WSS-M2C942-A
Motorcraft® Silicone Gasket and Sealant TA-30	WSE-M4G323-A4

Removal

NOTE: Aluminum cover shown, steel cover similar.

1. If equipped with aluminum cover, remove the panhard rod. Refer to [Section 204-02](#).
2. If equipped.

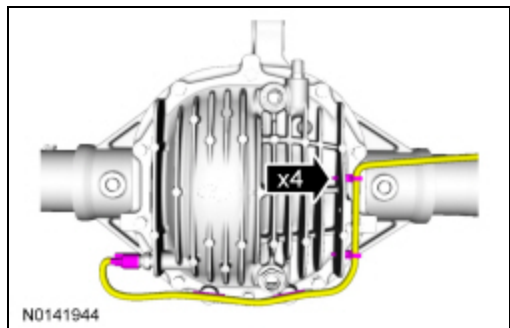

3. If equipped.
 - To install, tighten the bolt to 10 Nm (89 lb-ft).

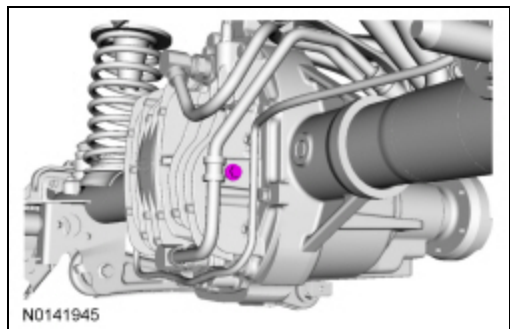

4. If equipped.

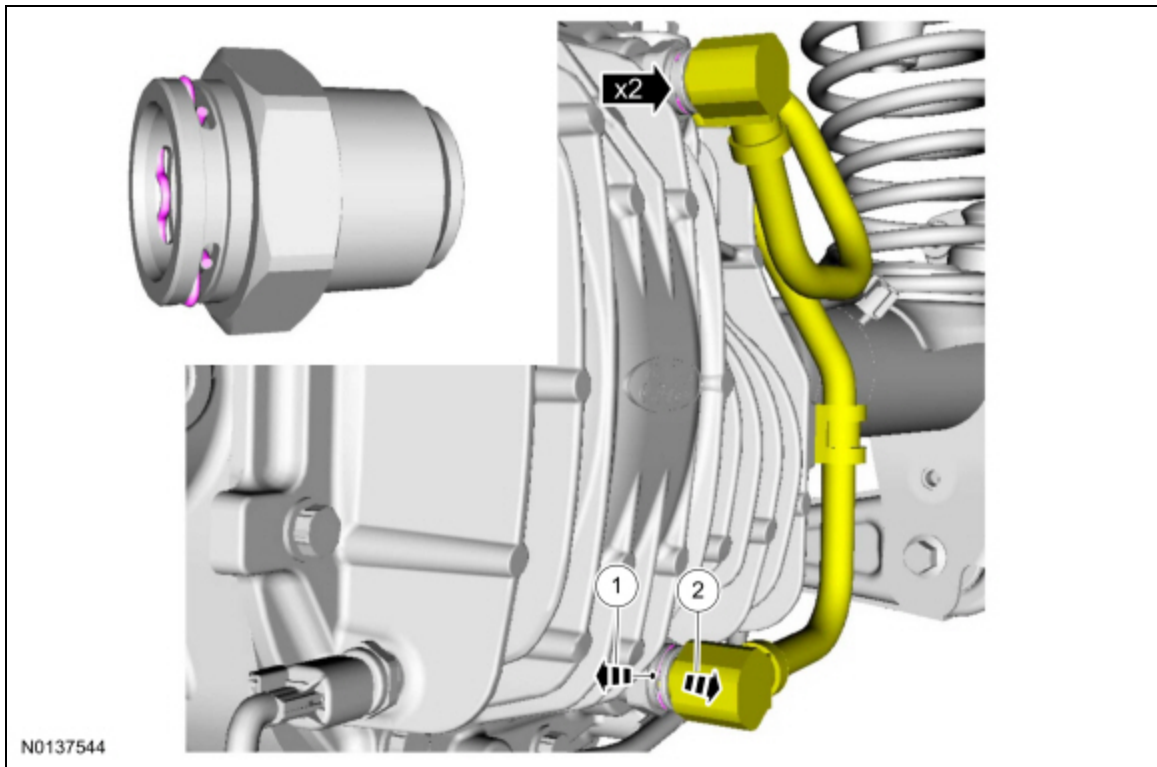

5. **NOTE:** The differential housing cover must be installed within 15 minutes of application of the silicone sealant, or new sealant must be applied. If possible, allow one hour before filling the axle housing with axle lubricant to make sure the silicone sealant has cured.

- To install, tighten steel cover bolts to 46 Nm (34 lb-ft).
- To install, tighten aluminum cover bolts to 32 Nm (24 lb-ft).

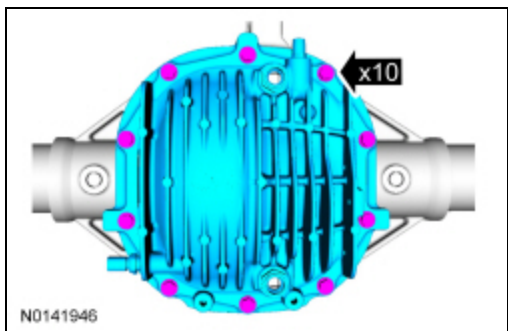

Installation

1. **NOTICE:** Make sure the machined surfaces on both the axle housing and the differential housing cover are clean and free of oil before installing the new silicone sealant. The inside of the axle housing must be covered when cleaning the machined surface to prevent contamination.

Apply a continuous bead of the specified diameter from the specified cartridge.

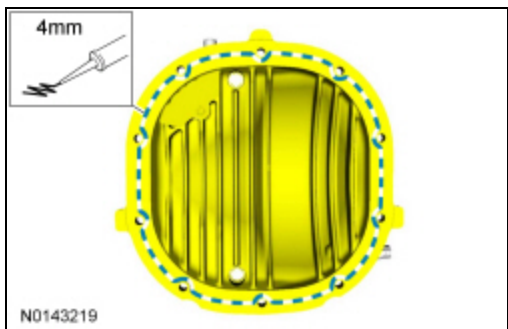

2. To install, reverse the removal procedure.

3. **NOTE:** *Service refill capacities are determined by filling the axle to a level of 5mm below the bottom of the fill hole with the axle at ride height.*

Remove the axle plug and fill the axle with 1.89-2.01L (4-4.25 pt) of axle lubricant and a additional 4.0 oz of friction modifier additive, vehicles with a differential cooler then use a scan tool to operate the oil cooler pump and add a additional 1.10L (2 pt) of axle lubricant and a additional 2 oz of friction modifier and install the filler plug.

- Tighten the plug to 30 Nm (22 lb-ft).

© Copyright 2024, Ford Motor Company.
