

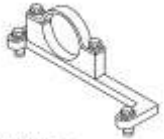



Camshafts

Special Tool(s)

 <p>ST1777-A</p>	Holding Tool, Camshaft Sprocket 303-564 (T97T-6256-B) or equivalent
 <p>ST1776-A</p>	Adapter for 303-564 303-578 (T97T-6256-A) or equivalent
 <p>ST1775-A</p>	Timing Tool, Crankshaft TDC 303-573 (T97T-6303-A) or equivalent
 <p>ST1780-A</p>	Extension, Torque Wrench 303-575 (T97T-6256-F) or equivalent
 <p>ST1781-A</p>	Socket, Camshaft Sprocket Nut 303-565 (T97T-6256-G)

Material

Item	Specification
Motorcraft SAE 5W-30 Premium Synthetic Blend Motor Oil XO-5W30-QSP (US); Motorcraft SAE 5W-30 Super Premium Motor Oil CXO-5W30-LSP12 (Canada); or equivalent	WSS-M2C929-A

Removal

Both sides

- NOTE:** Early build engines are equipped with an oil supply tube mounted above the camshaft that provides lubrication to the camshaft lobe/roller follower. Late build engines are equipped with an updated roller follower that performs the function of lubricating the camshaft lobe/roller follower. Therefore, the roller followers are not interchangeable between early build and late build engines.

Remove the camshaft roller followers. For additional information, refer to [Camshaft Roller Follower](#) in this section.

- NOTE:** The RH and LH camshaft timing procedure must be carried out when either camshaft is serviced.

Rotate the crankshaft clockwise to position the No. 1 cylinder at TDC.

3. **NOTICE: Do not rotate the engine counterclockwise. Rotating the engine counterclockwise will result in incorrect timing of the engine.**

NOTE: The special tool must be installed on the damper and should contact the engine block. This positions the piston at TDC.

Install the special tool.

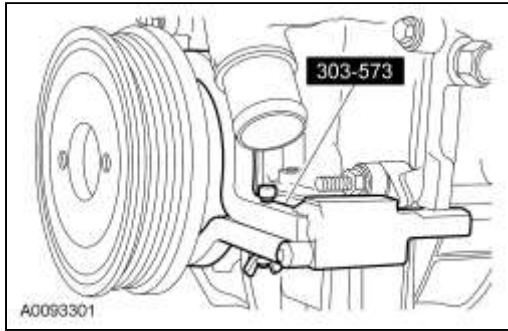

RH side

4. Install the special tools on the rear of the RH cylinder head and tighten the top 2 clamp bolts to 10 Nm (89 lb-in).

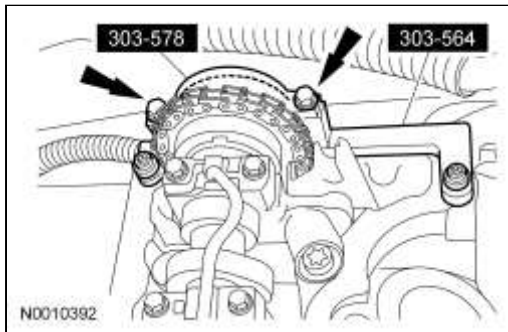

5. **NOTICE: The RH camshaft sprocket is a LH-threaded bolt.**

Using the special tool and the Camshaft Sprocket Nut Socket, loosen the camshaft sprocket bolt.

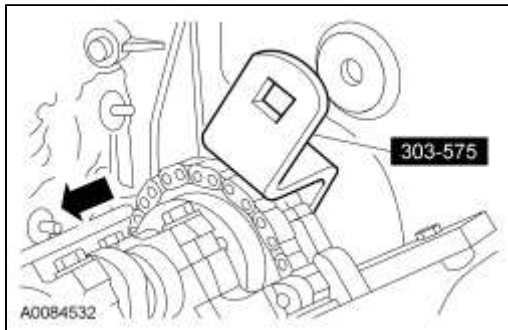

6. Remove the bolt and position the RH camshaft sprocket aside.

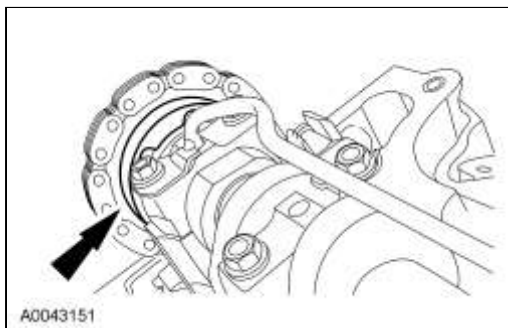

LH side

7. Install the special tools on the front of the LH camshaft and tighten the 2 top clamp bolts to 10 Nm (89 lb-in).

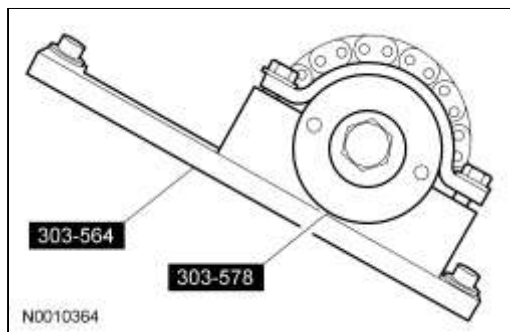

8. Loosen the bolt.

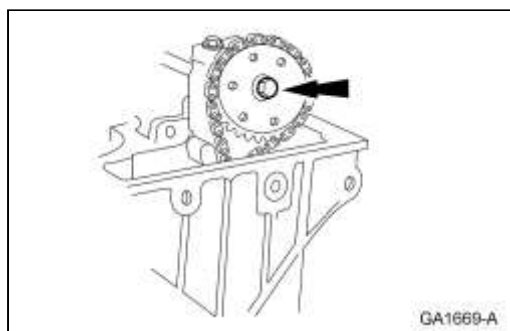

9. Remove the bolt and position the LH camshaft sprocket aside.

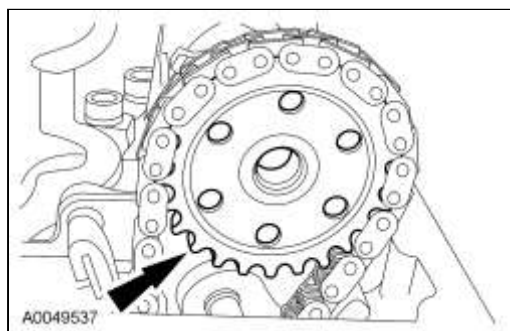

Both sides

10. **NOTE:** Mark the position of the camshaft bearing caps so they can be installed in their original positions.

Remove the bolts in the sequence shown and remove the camshaft bearing caps and, if equipped, the oil supply tube.

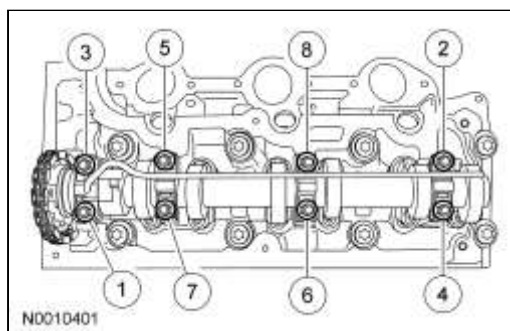

11. Remove the camshaft.

Installation

Both sides

1. **NOTE:** Lubricate the camshafts with clean engine oil.

Install the camshaft.

2. **NOTE:** Lubricate the camshaft bearing caps with clean engine oil.

NOTE: The camshaft bearing caps must be installed in their original positions.

NOTE: After installing the bolts, check the camshaft for free rotation.

Position the oil supply tube (if equipped), the camshaft bearing caps and the bolts.

- Tighten the bolts in the sequence shown in 2 stages.
 - Stage 1: Tighten to 6 Nm (53 lb-in).
 - Stage 2: Tighten to 16 Nm (12 lb-ft).

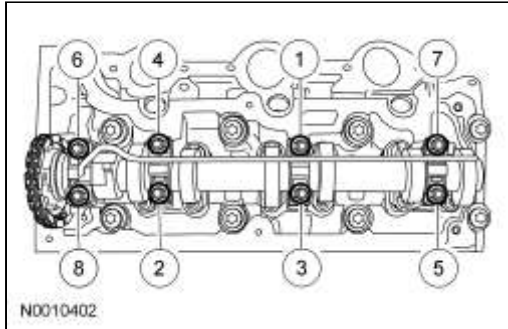

RH side

3. **NOTICE:** The camshaft gear must turn freely on the camshaft. **DO NOT** tighten the bolt at this time.

Install the RH camshaft sprocket and loosely install the bolt.

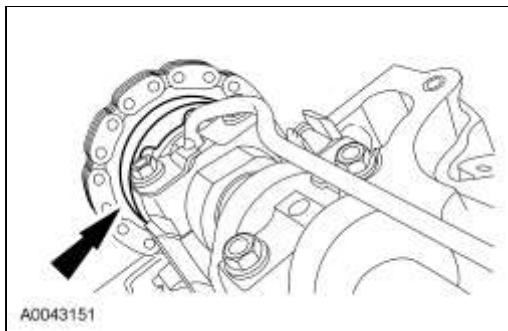

LH side

4. **NOTICE:** The camshaft gear must turn freely on the camshaft. **DO NOT** tighten the bolt at this time.

Install the LH camshaft sprocket and loosely install the bolt.

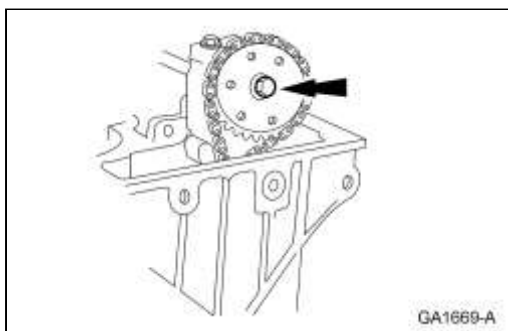

Both sides

5. Retime the camshafts. For additional information, refer to [Camshaft Timing](#) in this section.

6. Install the camshaft roller followers. For additional information, refer to [Camshaft Roller Follower](#) in this section.

