

# REMOVAL AND INSTALLATION

## Upper Arm Bushing

### Special Tool(s)

 <p>ST1535-A</p>	<p>Adapter 204-034 (T78P-5638-A4)</p>
 <p>ST1124-A</p>	<p>Receiver Cup 205-813</p>
 <p>ST2942-A</p>	<p>Remover/Installer, Bushing 204-590</p>
 <p>ST1869-A</p>	<p>Forcing Screw 205-813</p>

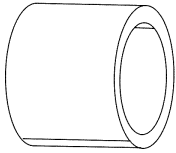
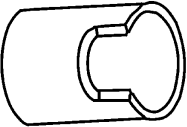
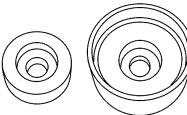
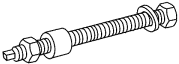
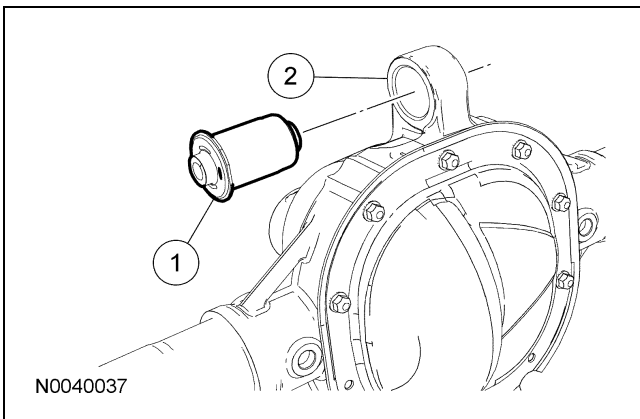

Item	Part Number	Description
1	5A638	Upper control arm bushing
2	4001	Rear drive axle

### Removal

**⚠ CAUTION:** Suspension fasteners are critical parts because they affect performance of vital parts and systems and their failure can result in major service expense. A new part with the same part number must be installed if installation becomes necessary. Torque values must be used as specified during reassembly to make sure of correct retention of these parts.

1. Mark the rear shock absorber relative to the protective sleeve with the vehicle in a static, level ground position (curb height).

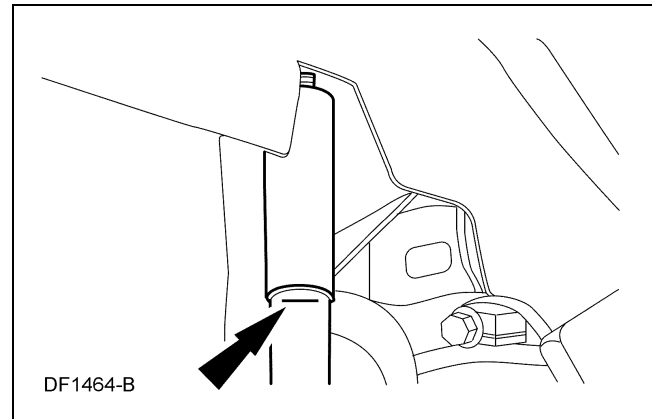

2. With the vehicle in NEUTRAL, position it on a hoist. For additional information, refer to Section 100-02.
3. **⚠ CAUTION:** Do not support the rear axle at the differential housing.  
Using 2 suitable jack stands, support the rear axle.
4. Remove and discard the upper control arm bushing nut and flag bolt.

**REMOVAL AND INSTALLATION (Continued)**

- Partially lower the rear axle and, using the special tools, remove the upper control arm bushing.

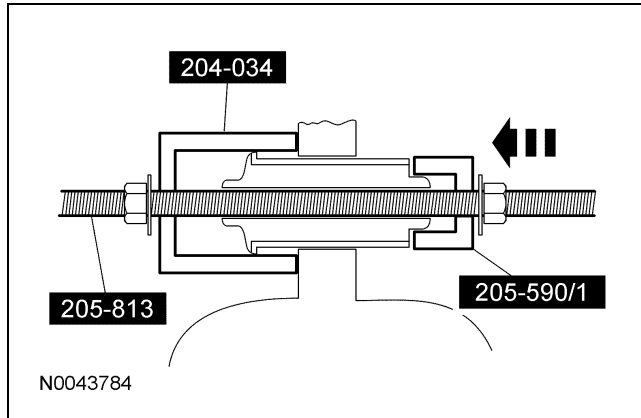

- Install the bushing so there is a 12 mm (0.47 in) gap between the bushing flange and the rear axle bracket.

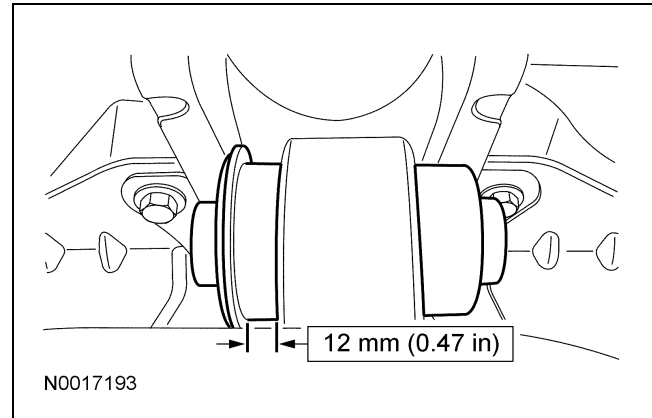
**Installation**

- Position the new bushing into the rear axle bracket with the voids in the rubber positioned at the top and bottom of the bushing.

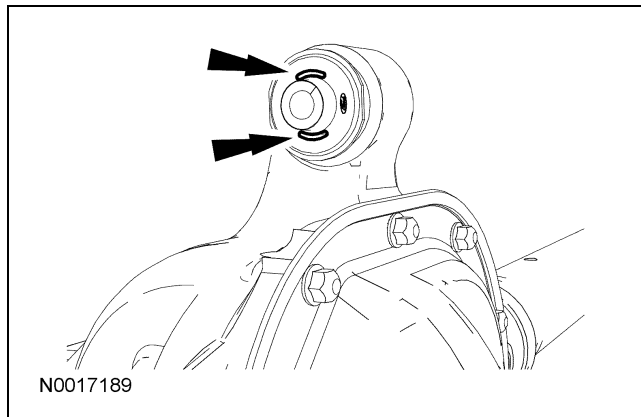

- Raise the rear axle so the mark made on the rear shock absorber in Removal Step 1 lines up with the protective sleeve.

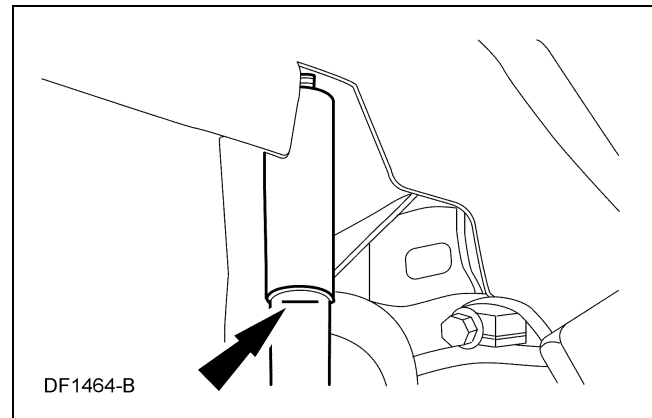

- Using the special tools, install the upper control arm bushing.

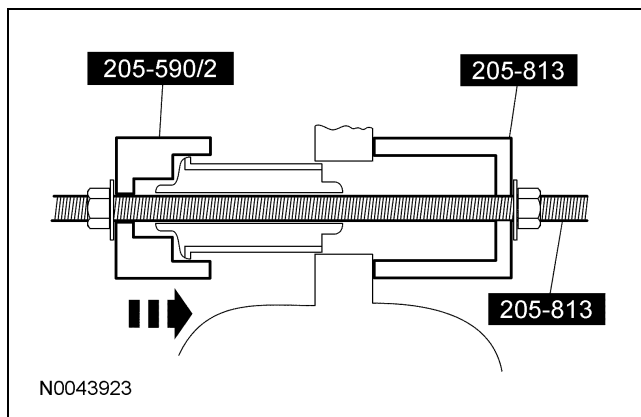

- ⚠ CAUTION: Tighten the upper control arm rear nut with the suspension at curb height.**

Install a new upper control arm rear nut and flag bolt.

- Tighten to 175 Nm (129 lb-ft).