

Glass, Frames and Mechanisms

The door window mechanism should be well lubricated to provide ease of operation. The window glass mechanism should be lubricated whenever the glass channel or window regulator is removed or excessive effort is required to operate the windows. Lubricate entire surface prior to assembly with Multi-Purpose Grease (spray) D7AZ-19584-AA (ESB-M1C106-B and ESR-M1C159-A) or equivalent. To lubricate a door window mechanism, apply an even coating of Multi-Purpose Grease (tube) D0AZ-19584-AA (ESB-M1C93-A and ESR-M1C159-A) or equivalent to the window regulator rollers, shafts and entire length of the roller guides as illustrated by the shaded areas.

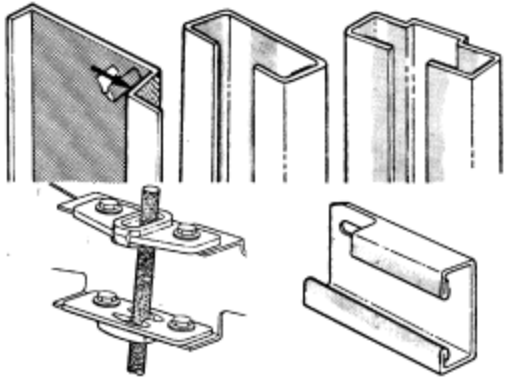

APPLY AN EVEN COATING OF MULTI-PURPOSE GREASE D0AZ-19584-AA TO ALL WINDOW REGULATOR ROLLERS, SHAFTS AND THE ENTIRE LENGTH OF ROLLER GUIDES AS ILLUSTRATED BY THE SHADED AREAS
N1607-H