

**TECHNICAL SERVICE BULLETIN****Poor Air Conditioning (A/C) Performance - Evaporator Can Now Be Serviced Separately From The Climate Control Housing**

This bulletin supersedes 18-2166. Reason for update: Replace Awareness/Interim Message

Model:

Ford 2015-2017 Mustang

Summary

This article supersedes TSB 18-2166 to update the causal part.

Issue: Some 2015-2017 Mustang vehicles may exhibit poor A/C performance. If the cause of this is found to be a refrigerant leak from the evaporator, it is recommended to replace only the evaporator as opposed to the entire climate control housing.

Action: Follow the Service Procedure steps to correct the condition.

Parts

Service Part Number	Package Order Quantity	Description
FR3Z-19860-A	1	Evaporator Core Service Kit (2.3L Engine)
FR3Z-19860-B	1	Evaporator Core Service Kit (3.7L, 5.0L, & 5.2L Engine)
W715969-S442	1	Upper Instrument Panel Cowl Bolts (4 per package)
W714878-S450	1	Steering Shaft Bolt (4 per package)
6E5Z-19E889-D	1	Thermostatic Expansion Valve Upper O-Ring Seal
6E5Z-19E889-E	1	Thermostatic Expansion Valve Lower O-Ring Seal
YN-19	1	Motorcraft® R-134a Refrigerant
YN-12-D	1	Motorcraft® PAG Refrigerant Compressor Oil
VC-3-B	1	Motorcraft® Orange Concentrated Antifreeze/Coolant

Warranty Status: Eligible under provisions of New Vehicle Limited Warranty (NVLW)/Service Part Warranty (SPW)/Service Part New Vehicle (SPNV)/Extended Service Plan (ESP) coverage. Limits/policies/prior approvals are not altered by a TSB. NVLW/SPW/SPNV/ESP coverage limits are determined by the identified causal part and verified using the OASIS part coverage tool.

Labor Times

Description	Operation No.	Time
2015 Mustang Manual Transmission: Visually Inspect A/C System And Replace Evaporator Core Following The Service Procedure (Do Not Use With Any Other Labor Operations)	182256A	4.9 Hrs.
2016-2017 Mustang Manual Transmission: Visually Inspect A/C System And Replace Evaporator Core Following The Service Procedure (Do Not Use With Any Other Labor Operations)	182256B	5.1 Hrs.
2015 Mustang Automatic Transmission: Visually Inspect A/C System And Replace Evaporator Core Following The Service Procedure (Do Not Use With Any Other Labor Operations)	182256C	5.2 Hrs.
2016-2017 Mustang Automatic Transmission: Visually Inspect A/C System And Replace Evaporator Core Following The Service Procedure (Do Not Use With Any Other Labor Operations)	182256D	5.4 Hrs.

Repair/Claim Coding

Causal Part:	19860
Condition Code:	D7

Drive	Tool Name
1/4"	Impact
1/4"	Power Ratchet
1/4"	Ratchet
1/4"	Long Handle Ratchet
1/4"	Torque Wrench
1/4"	6" Extension
1/4"	8" Extension
1/4"	Universal Joint
1/4"	10 mm Deep Socket
1/4"	Torx® T27
1/4"	Torx® T20
1/4"	7 mm Socket
1/4"	8 mm Socket
3/8"	Ratchet
3/8"	Torque Wrench
3/8"	6" Extension
3/8"	10" Extension
3/8"	13 mm Deep Socket
3/8"	15 mm Deep Socket
3/8"	19 mm Deep Socket
3/8"	13 mm Socket
3/8"	15 mm Socket
3/8"	Hex #4
3/8"	Torx® T40
3/8"	13 mm Crows Foot
3/8"	19 mm Crows Foot
3/8"	13 mm Swivel Socket
	Pocket Flathead Screwdriver
	Medium Flathead Screwdriver
	19 mm Wrench
	13 mm Flex Head Ratchet Wrench
	10 mm Flex Head Ratchet Wrench
	Plastic Trim Tool
	Metal Trim Tool

Service Procedure

1. Inspect the A/C system. Does the system show signs of leaks in components other than the evaporator?
 - (1). Yes – this article does not apply. Refer to Workshop Manual (WSM), Section 412-00.
 - (2). No – proceed to Step 2.
2. Remove the climate control housing. Refer to WSM, Section 412-00.
3. Disconnect and position the wiring harnesses aside. (Figures 1 - 2)

Figure 1

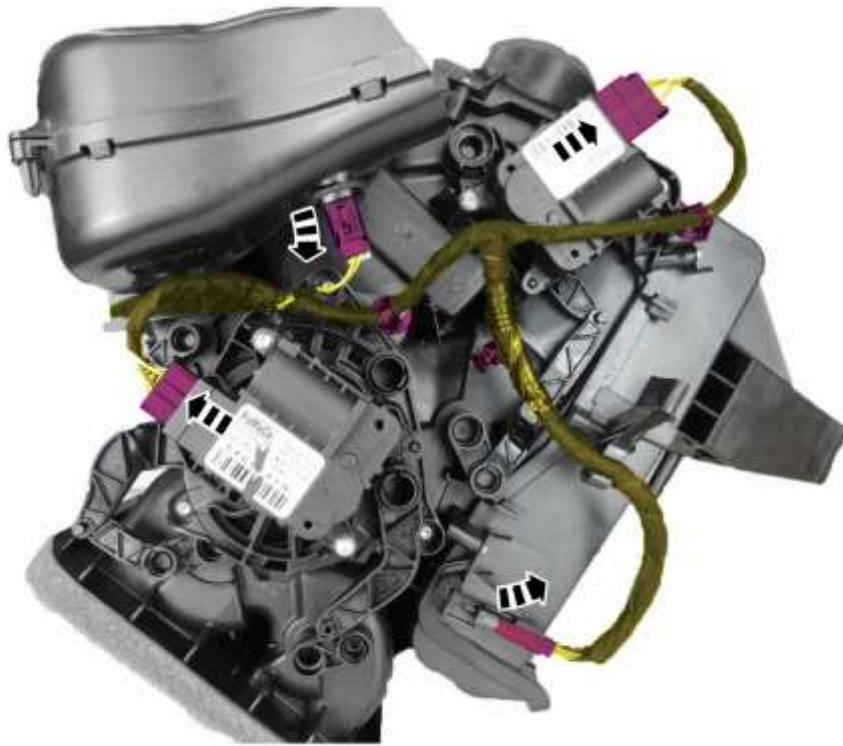

E284057

Figure 2

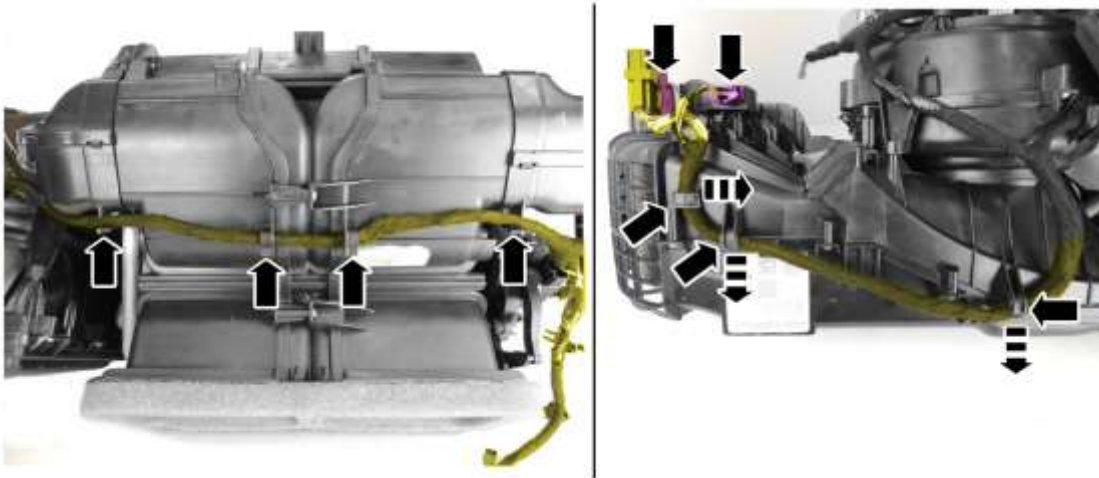

E284058

4. If equipped with dual zone climate control, disconnect the passenger blend door actuator electrical connector and remove the 3 upper plenum housing to blower motor fasteners. (Figure 3)

Figure 3

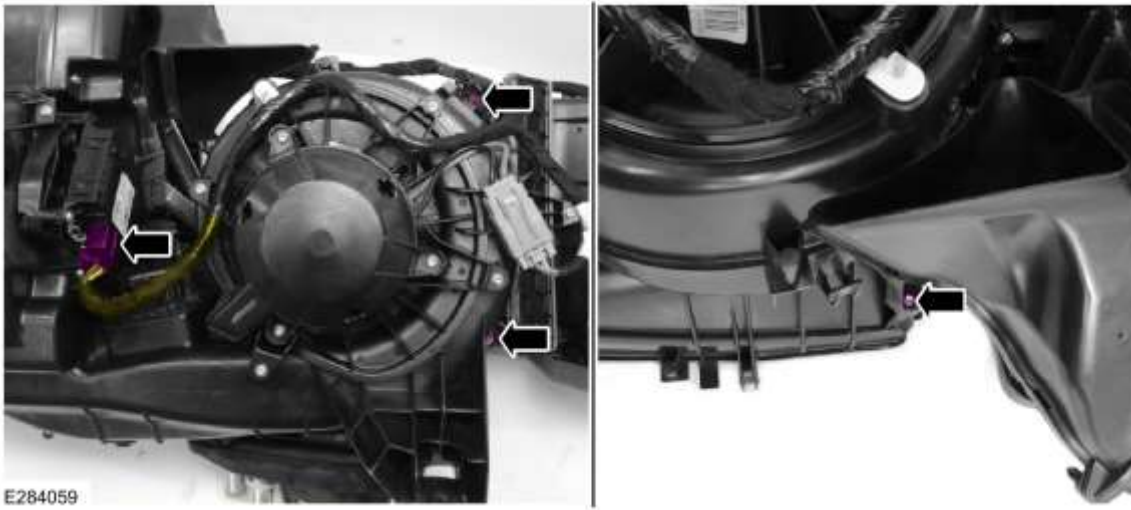

5. Remove the 4 upper plenum housing to blower motor fasteners. (Figure 4)

Figure 4

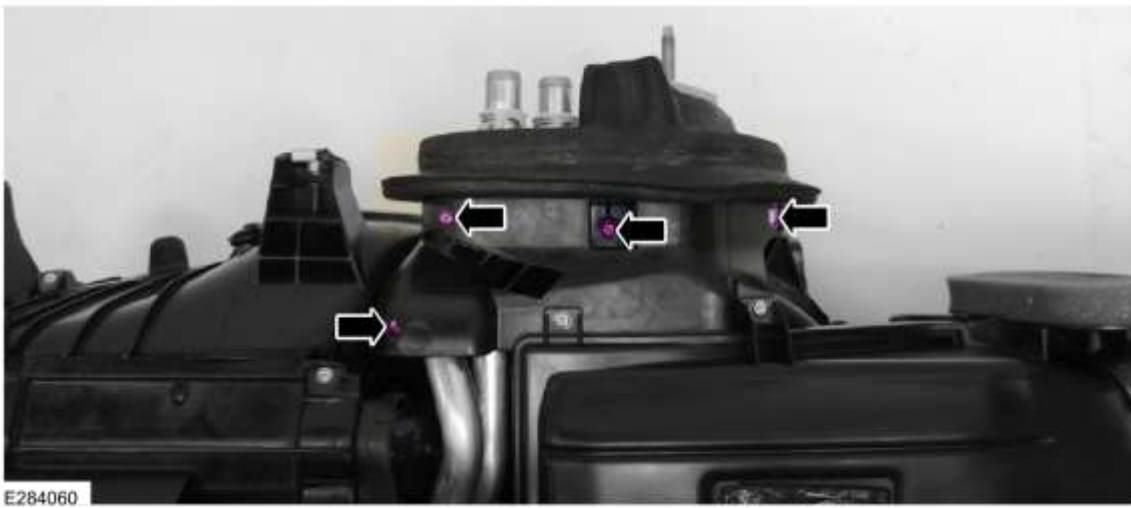

6. Position the climate control housing to bulkhead insulator aside and remove the upper plenum housing from the climate control housing. (Figure 5)

Figure 5

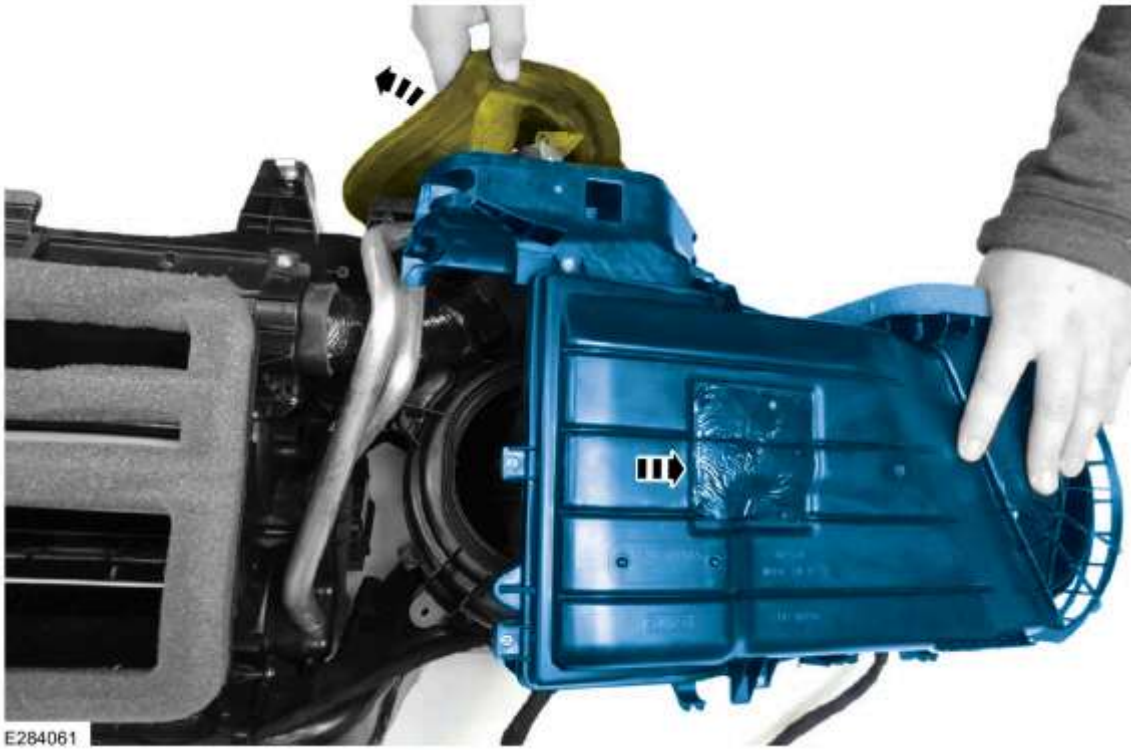

E284061

7. Remove the 2 footwell duct to climate control housing fasteners and remove the footwell duct. (Figure 6)

Figure 6



E284062

8. Remove the 2 heater core outlet pipe cover fasteners from the climate control housing and remove the cover. (Figure 7)

Figure 7



E284063

9. Remove the 2 climate control housing perimeter fasteners. (Figure 8)

Figure 8



E284064

10. Remove the 3 climate control housing perimeter fasteners. (Figure 9)

Figure 9

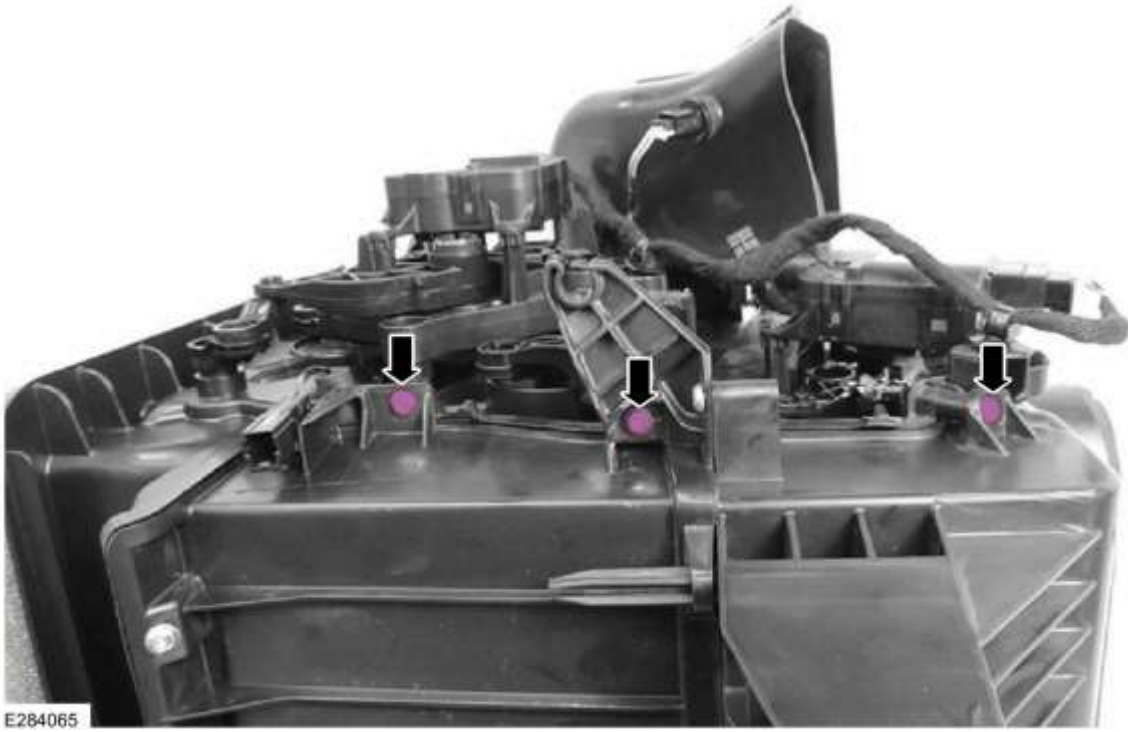

E284065

11. Remove the 4 climate control housing lower perimeter fasteners. (Figure 10)

Figure 10

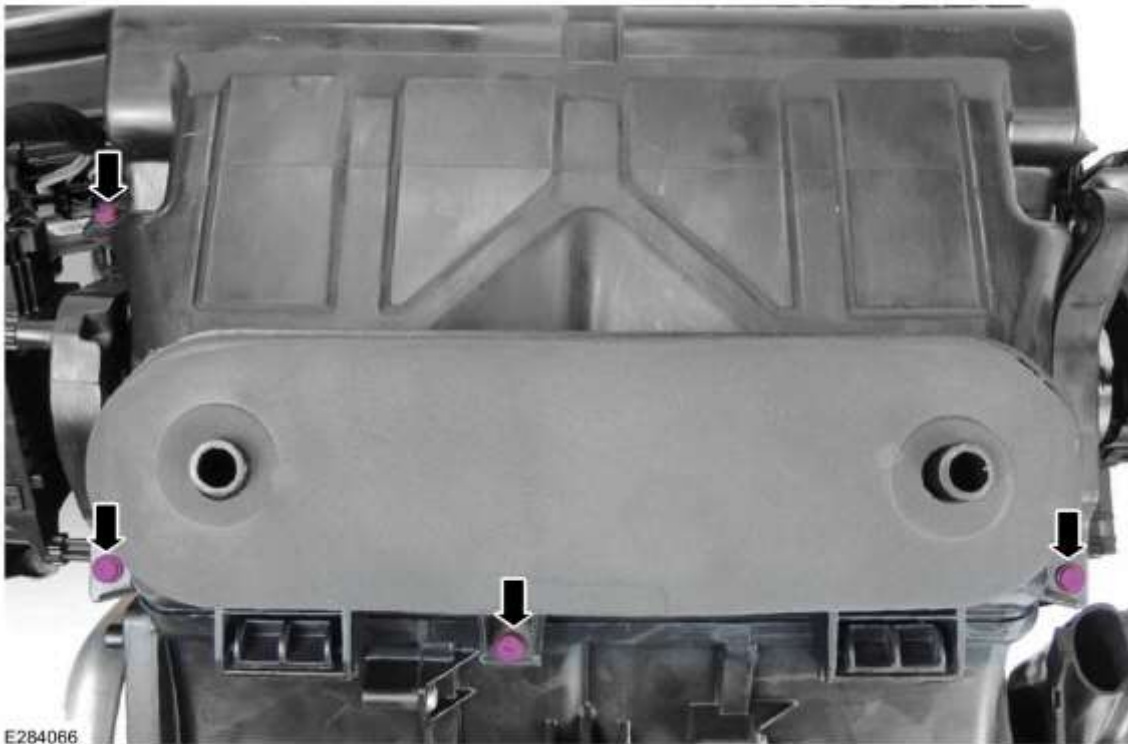

E284066

12. Remove the 4 climate control assembly perimeter fasteners. (Figure 11)

Figure 11

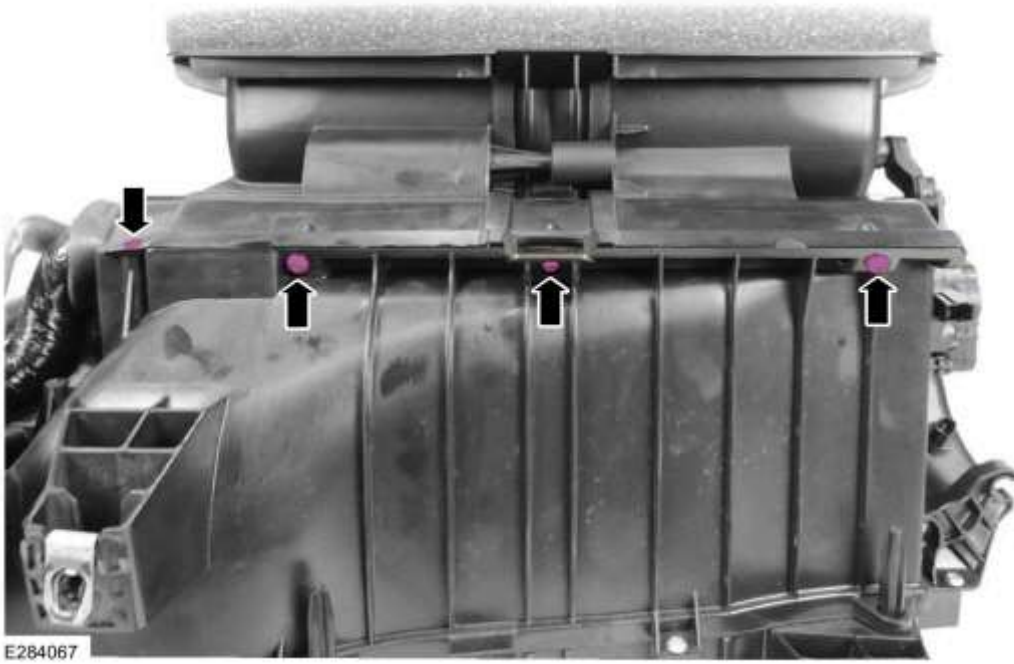

13. Position the bulkhead insulator over the thermostatic expansion valve (TXV). (Figure 12)

Figure 12



14. Remove the plenum chamber and heater core as an assembly from the climate control core housing. (Figure 13)

Figure 13

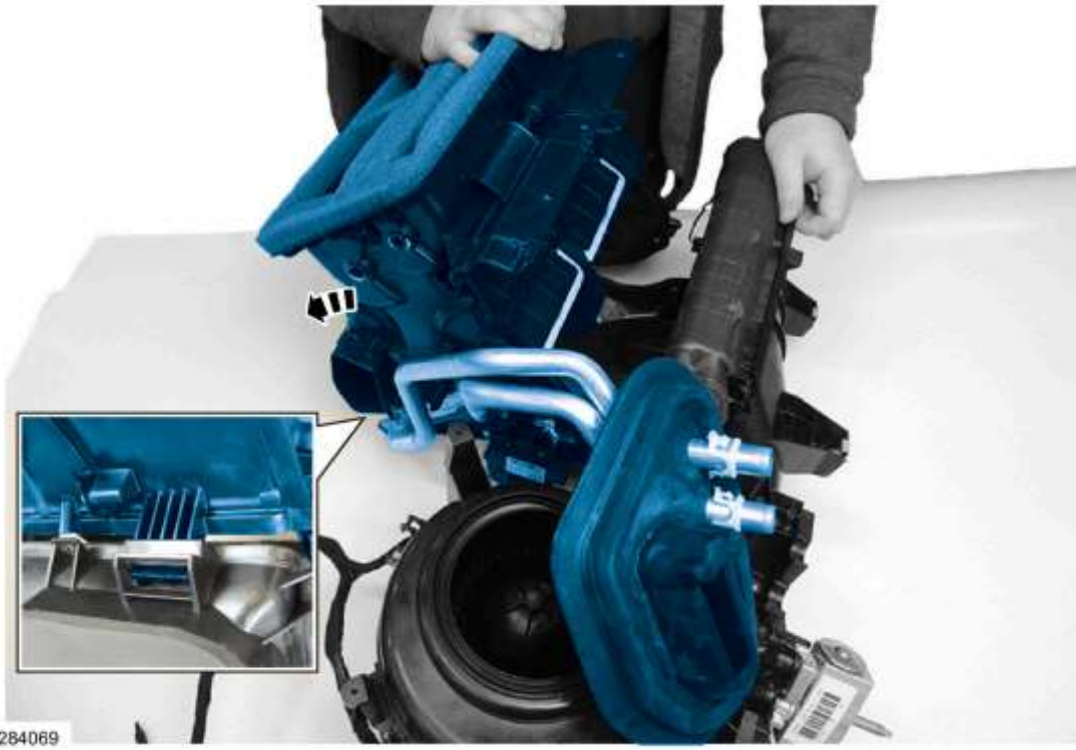

E284069

15. Remove the evaporator temperature sensor wiring seal from the slot in the climate control housing. (Figure 14)

Figure 14

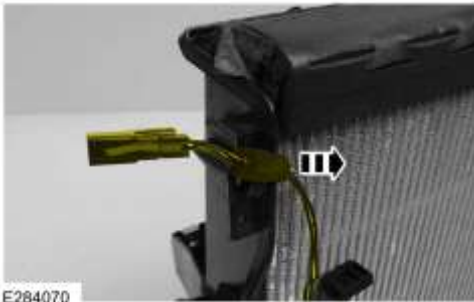

E284070

16. Remove the evaporator core from the climate control housing. (Figure 15)

Figure 15



E284071

17. Install the new evaporator core. Push down on the evaporator core firmly to make sure it is fully seated in the climate control housing. (Figure 16)

Figure 16



E284072

18. The new evaporator core may require a minor adjustment to the lines in order to fit properly in the climate control housing. (Figure 17)

Figure 17



E284073

19. Install the evaporator temperature sensor wiring seal into the slot in the climate control housing. (Figure 18)

Figure 18



E284074

20. Assemble the two climate control housing halves.

(1). Push down on the corners of the housing, not the center tab.

(2). The housing fasteners may need to be started in order to draw the two halves together due to the new evaporator core foam being uncompressed. (Figure 19)

Figure 19

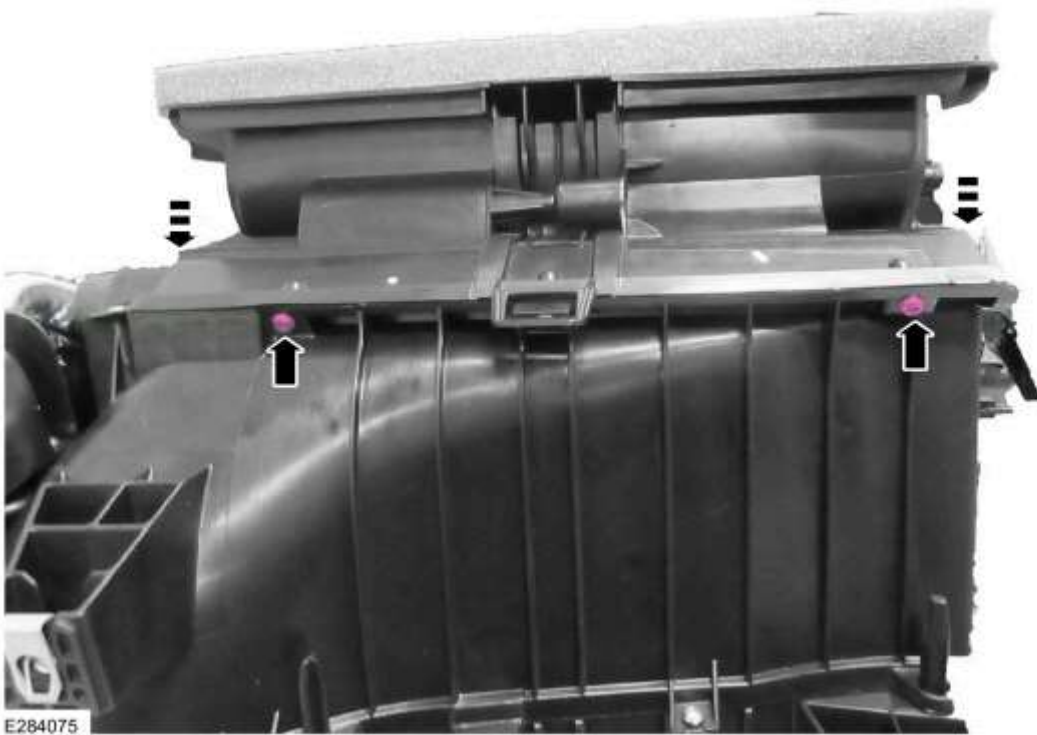

E284075

21. Install the bulkhead insulator over the TXV. (Figure 12)

22. Install the 4 climate assembly perimeter fasteners. (Figure 11)

23. Install the 4 climate control housing lower perimeter fasteners. (Figure 10)

24. Install the 3 climate control housing perimeter fasteners. (Figure 9)

25. Install the 2 climate control housing perimeter fasteners. (Figure 8)

26. Install the heater core outlet pipe cover and the 2 fasteners in the climate control housing. (Figure 7)

27. Install the footwell duct to the climate control housing and install the two fasteners. (Figure 6)
28. Install the upper plenum housing to the climate control housing and position the bulkhead insulator back on. (Figure 5)
29. Install the 4 upper plenum housing to blower motor fasteners. (Figure 4)
30. If equipped with dual zone climate control, connect the passenger blend door actuator electrical connector and install the 3 upper plenum housing to blower motor fasteners. (Figure 3)
31. Connect and position the wiring harness into the anchor points. (Figure 2)
32. Connect and position the wiring harness back together. (Figure 1)
33. Apply the supplied black putty to the outside of the climate control housing where the two case halves come together. (Figure 20)

Figure 20



34. Remove the old climate control housing assembly foam isolator and apply the new foam isolator. (Figure 21)

Figure 21



35. Reinstall the climate control housing. Refer to WSM, Section 412-00.

- (1). Prior to connecting the lines, replace the rubber O-ring gaskets between the A/C lines and evaporator core.
- (2). Prior to charging the A/C system, evacuate the system for a minimum of 45 minutes using a refrigerant service unit. After 45 minutes turn off the vacuum pump and monitor the low pressure gauge for a minimum of 15 minutes to make sure no other refrigerant leaks are present. Refer to WSM, Section 412-00.

© 2018 Ford Motor Company

All rights reserved.

NOTE: The information in Technical Service Bulletins is intended for use by trained, professional technicians with the knowledge, tools, and equipment to do the job properly and safely. It informs these technicians of conditions that may occur on some vehicles, or provides information that could assist in proper vehicle service. The procedures should not be performed by "do-it-yourselfers". Do not assume that a condition described affects your car or truck. Contact a Ford or Lincoln dealership to determine whether the Bulletin applies to your vehicle. Warranty Policy and Extended Service Plan documentation determine Warranty and/or Extended Service Plan coverage unless stated otherwise in the TSB article. The information in this Technical Service Bulletin (TSB) was current at the time of printing. Ford Motor Company reserves the right to supersede this information with updates. The most recent information is available through Ford Motor Company's on-line technical resources.