



Smart Junction Box (SJB)

Special Tool(s)

	Fluke 77-IV Digital Multimeter FLU77-4 or equivalent
	Vehicle Communication Module (VCM) and Integrated Diagnostic System (IDS) software with appropriate hardware, or equivalent scan tool
	Flex Probe Kit 300-NUD105-R025DE or equivalent

Principles of Operation

NOTE: The Smart Junction Box (SJB) is also known as the Generic Electronic Module (GEM) .

The SJB controls various systems by monitoring inputs from switches, sensors and messages sent from other modules on the Medium Speed Controller Area Network (MS-CAN) . Based on the inputs received, the SJB activates outputs. For example, the SJB monitors the headlamp switch position. Based on this input, the SJB may provide voltage to the exterior lamps.

Field-Effect Transistor (FET) Protection

A Field-Effect Transistor (FET) is a type of transistor that when used with module software can be used to monitor and control current flow on module outputs. The FET protection strategy is used to prevent module damage in the event of excessive current flow.

The SJB utilizes an FET protective circuit strategy for many of its outputs (for example, a headlamp output circuit). Output loads (current level) are monitored for excessive current (typically short circuits) and are shut down (turns off the voltage or ground provided by the module) when a fault event is detected. A short circuit DTC is stored at the fault event and a cumulative counter is started.

When the demand for the output is no longer present, the module resets the FET circuit protection to allow the circuit to function. The next time the driver requests a circuit to activate that has been shut down by a previous short (FET protection) and the circuit is still shorted, the FET protection shuts off the circuit again and the cumulative counter advances.

When the excessive circuit load occurs often enough, the module shuts down the output until a repair procedure is carried out. Each FET protected circuit has 3 predefined levels of short circuit tolerance based on the harmful effect of each circuit fault on the FET and the ability of the FET to withstand it. A module lifetime level of fault events is established based upon the durability of the FET . If the total tolerance level is determined to be 600 fault events, the 3 predefined levels would be 200, 400 and 600 fault events.

When each tolerance level is reached, the short circuit DTC that was stored on the first failure cannot be cleared by a command to clear the continuous DTCs. The module does not allow this code to be cleared or the circuit restored to normal operation until a successful self-test proves that the fault has been repaired. After the self-test has successfully completed (no on-demand DTCs present), DTC B106E and the associated DTC (the DTC related to the shorted circuit) automatically clears and the circuit function returns.

When each level is reached, the DTC associated with the short circuit sets along with DTC B106E. These DTCs can be cleared using the module on-demand self-test, then the Clear DTC operation on the scan tool (if the on-demand test shows the fault corrected). The module never resets the fault event counter to zero and continues to advance the fault event counter as short circuit fault events occur.

If the number of short circuit fault events reach the third level, then DTCs B106F and B1342 set along with the associated short circuit DTC. DTC B106F cannot be cleared and the module must be replaced after the repair.

Inspection and Verification

1. Verify the customer concern.
2. Visually inspect for obvious signs of electrical damage.

Visual Inspection Chart

Electrical

- Smart Junction Box (SJB) fuse 5 (10A)
- Wiring, terminals or connectors
- SJB

3. If an obvious cause for an observed or reported concern is found, correct the cause (if possible) before proceeding to the next step.

4. **NOTE:** *Make sure to use the latest scan tool software release.*

If the cause is not visually evident, connect the scan tool to the Data Link Connector (DLC) .

5. **NOTE:** *The Vehicle Communication Module (VCM) LED prove-out confirms power and ground from the DLC are provided to the VCM .*

If the scan tool does not communicate with the VCM

- Check the VCM connection to the vehicle.
- Check the scan tool connection to the VCM .
- Refer to [Section 418-00](#), No Power To The Scan Tool, to diagnose no power to the scan tool.

6. If the scan tool does not communicate with the vehicle:

- Verify the ignition is in the ON state.
- Verify the scan tool operation with a known good vehicle.
- Refer to [Section 418-00](#) to diagnose no response from the PCM.

7. Carry out the network test.

- If the scan tool responds with no communication for one or more modules, refer to [Section 418-00](#).
- If the network test passes, retrieve and record the continuous memory DTCs.

8. Clear the continuous DTCs and carry out the self-test diagnostics for the SJB .

9. If the DTCs retrieved are related to the concern, go to the Smart Junction Box (SJB) DTC Chart.

10. If no DTCs related to the concern are retrieved, GO to [Symptom Chart](#).

DTC Charts

Smart Junction Box (SJB) DTC Chart

DTC	Description	Action
B106B	Tire Pressure Sensor Low Battery	REFER to Section 204-04 .
B106D	Tire Pressure Monitor System (TPMS) Initiators Not Configured	REFER to Section 204-04 .
B106E	Solid State Driver Disabled Due to Short Circuit	GO to Pinpoint Test A .
B106F	Module Disabled Due to External Fault	GO to Pinpoint Test A .
B1138	Memory Full	REFER to Section 419-01B .
B1139	Invalid Transmitter Identification Code	REFER to Section 501-14 .
B1302	Accessory Delay Relay Coil Circuit Failure	REFER to Section 501-11 .
B1304	Accessory Delay Relay Coil Circuit Short To Battery	REFER to Section 501-11 .
B1317	Battery Voltage High	GO to Pinpoint Test B .

DTC	Description	Action
B1318	Battery Voltage Low	GO to Pinpoint Test C.
B1320	Driver Door Ajar Circuit Open	REFER to Section 417-02.
B1328	Passenger Door Ajar Circuit Open	REFER to Section 417-02.
B1331	Decklid Ajar Rear Door Circuit Failure	REFER to Section 417-02.
B1342	ECU Is Faulted	DIAGNOSE all other DTCs first. If no other DTCs are present, INSTALL a new SJB . REFER to Smart Junction Box (SJB) in this section. TEST the system for normal operation.
B1352	Ignition Key-In Circuit Failure	REFER to Section 413-01.
B1472	Lamp Headlamp Input Circuit Short To Ground	REFER to Section 417-01.
B1485	Brake Pedal Input Short To Battery	REFER to Section 417-01.
B1510	Flash To Pass Switch Circuit Short To Ground	REFER to Section 417-01.
B1520	Hood Switch Circuit Open	REFER to Section 419-01A.
B1578	Lamp Park Input Circuit Short To Ground	REFER to Section 417-01.
B1688	Lamp Dome Input Circuit Short To Ground	REFER to Section 417-02.
B1696	Autolamp On Circuit Short To Ground	REFER to Section 417-01.
B1791	Autolamp Sensor Input Circuit Open	REFER to Section 417-01.
B1793	Autolamp Sensor Input Circuit Short to Ground	REFER to Section 417-01.
B2008	Wipers On Signal Circuit Short to Ground	REFER to Section 417-01.
B2044	Left Rear Stop Lamp Circuit Short To Ground	REFER to Section 417-01.
B2046	Right Rear Stop Lamp Circuit Short To Ground	REFER to Section 417-01.
B2048	Left Rear Turn Lamp Circuit Short To Ground	REFER to Section 417-01.
B2050	Right Rear Turn Lamp Circuit Short To Ground	REFER to Section 417-01.
B2071	Hazard Switch Signal Short To Ground	REFER to Section 417-01.
B2100	Door Driver Key Cylinder Switch Failure	REFER to Section 419-01A.
B2212	Panel Dim Switch Out of Range	REFER to Section 413-00.
B2254	Front Fog Lamp Switch Failure	REFER to Section 417-01.
B2276	Less Than 2 Transmitters Programmed	REFER to Section 501-14.
B2281	Right Turn Switch Short To Ground	REFER to Section 417-01.
B2282	Left Turn Switch Short To Ground	REFER to Section 417-01.

DTC	Description	Action
B2425	Remote Keyless Entry Out of Synchronization	REFER to Section 501-14 .
B2477	Module Configuration Failure	CARRY OUT Programmable Module Installation (PMI) on the <u>SJB</u> . REFER to Section 418-01 .
B2479	Park Brake Switch Circuit Short To Ground	REFER to Section 413-01 .
B2494	Anti-Theft Horn Output Circuit Short to Battery	Diagnose all other DTCs and symptoms before proceeding. Using as built data, CARRY out Programmable Module Installation (PMI) on the <u>SJB</u> . REFER to Section 418-01 . CLEAR the DTCs and verify successful module configuration. REPEAT the self-test. If DTC B2494 is retrieved again, INSTALL a new <u>SJB</u> . REFER to Smart Junction Box (SJB) in this section.
B2498	Headlamp Switch Multiple Signals Input Active	REFER to Section 417-01 .
B2572	Brake Shift Interlock Output Circuit Failure	REFER to Section 307-05 .
B2844	Ignition Fault	REFER to Section 211-05 .
B2868	Left Front Tire Pressure Sensor Fault	REFER to Section 204-04 .
B2869	Right Front Tire Pressure Sensor Fault	REFER to Section 204-04 .
B2870	Right Rear Tire Pressure Sensor Fault	REFER to Section 204-04 .
B2871	Left Rear Tire Pressure Sensor Fault	REFER to Section 204-04 .
B2872	Tire Pressure Sensor Fault	REFER to Section 204-04 .
B287A	Tire Pressure System Fault	REFER to Section 204-04 .
B2A20	Ignition Stuck in START	REFER to Section 211-05 .
B2A21	One or More Configuration Files Missing or Corrupt	CARRY out Programmable Module Installation (PMI) on the <u>SJB</u> . REFER to Section 418-01 . CLEAR the DTCs. REPEAT the self-test. If DTC B2A21 is retrieved again, INSTALL a new <u>SJB</u> . REFER to Smart Junction Box (SJB) in this section. TEST the system for normal operation.
B2A22	Headlamp OFF Circuit Open	REFER to Section 417-01 .
B2A23	High Beam Input Circuit Short To Ground	REFER to Section 417-01 .
B2A24	Turn Signal Input Circuit Failure	REFER to Section 417-01 .
B2A25	Trim Panel Lock Switch Circuit Failure	REFER to Section 501-14 .
B2A27	Right Front Turn Lamp Circuit Open	REFER to Section 417-01 .
B2A28	Right Front Turn Lamp Circuit Short to Ground	REFER to Section 417-01 .
B2A29	Left Front Turn Lamp Circuit Open	REFER to Section 417-01 .
B2A2A	Left Front Turn Lamp Circuit Short to Ground	REFER to Section 417-01 .
B2A2B	Left Corner Lamp Output Circuit Short to Ground	REFER to Section 417-01 .
B2A2C	Right Corner Lamp Output Circuit Short to Ground	REFER to Section 417-01 .
B2A2E	Right Front Lamp Low Beam Circuit Open	REFER to Section 417-01 .

DTC	Description	Action
B2A2F	Right Front Lamp Low Beam Circuit Short to Ground	REFER to Section 417-01 .
B2A30	Left Front Lamp Low Beam Circuit Open	REFER to Section 417-01 .
B2A31	Left Front Lamp Low Beam Circuit Short to Ground	REFER to Section 417-01 .
B2A32	LED Backlighting Output Circuit Open	REFER to Section 413-00 .
B2A33	LED Backlighting Output Circuit Short to Ground	REFER to Section 413-00 .
B2A35	Interior Lighting Output Circuit Open	REFER to Section 417-02 .
B2A36	Interior Lighting Output Circuit Short to Ground	REFER to Section 417-02 .
B2A38	Floor Lamp Output Circuit Short to Ground	REFER to Section 417-02 .
B2A3A	Puddle Lamp Output Circuit Short to Ground	REFER to Section 417-02 .
P062F	Internal Control Module EEPROM Error	CLEAR the DTCs. REPEAT the self-test. If DTC P062F is retrieved again, INSTALL a new SJB . REFER to Smart Junction Box (SJB) in this section. TEST the system for normal operation.
C1125	Brake Fluid Level Sensor Input Circuit Failure	REFER to Section 413-01 .
C2780	ECU in Manufacturer Sub-State	REFER to Section 204-04 .
U0155	Lost Communication With Instrument Panel Cluster (IC) Control Module	GO to Pinpoint Test D .
U2050	No Application Present	CARRY out Programmable Module Installation (PMI) on the SJB . REFER to Section 418-01 . CLEAR the DTCs. REPEAT the self-test. If DTC U2050 is retrieved again, INSTALL a new SJB . REFER to Smart Junction Box (SJB) in this section. TEST the system for normal operation.
U2472	Unexpected Ignition State	REFER to Section 211-05 .
U2473	Unexpected Vehicle Speed (VSS)	NOTE: Sets during the self-test if vehicle speed exceeds 3 mph (5 kph) or vehicle speed cannot be determined by the SJB . VERIFY the speedometer operates correctly. If the speedometer does not operate correctly, REFER to Section 413-01 . If the speedometer operates correctly, the self-test is carried out while the vehicle is moving. STOP the vehicle and REPEAT the self-test.

Symptom Chart

Symptom Chart

Condition	Possible Sources	Action
• No communication with the Smart Junction Box (SJB)	<ul style="list-style-type: none"> • Fuse • Wiring, terminals or connectors • SJB 	• REFER to Section 418-00 , The SJB Does Not Respond To The Scan Tool.

Pinpoint Tests

Pinpoint Test A: DTCs B106E, B106F

Normal Operation

The Smart Junction Box (SJB) controls the output of several vehicle systems by means of solid state drivers. A DTC sets when an overload occurs on any of these drivers. The module also tracks the number of repetitive faults on each of these circuits, and then it compares said number of overloads to 3 progressive thresholds established for each circuit. If the third threshold has not been met, the DTC for the affected circuit can be cleared by eliminating the fault, clearing the DTCs and then running a self-test.

At the point that each of the first 2 thresholds is met, DTC B106E sets along with a DTC related to the affected circuit. Once the final (third) threshold has been met, the affected output is permanently disabled, and DTC B106F sets, at which time the SJB must be replaced.

- DTC B106E (Solid State Driver Disabled Due to Short Circuit) — a continuous DTC that sets when the SJB has disabled an output circuit due to a repetitive fault that overloads said circuit. A corresponding DTC for the circuit in question is also set.
- DTC B106F (Module Disabled Due to External Fault) — a continuous DTC that sets when the SJB has permanently disabled one or more output functions due to a repetitive circuit overload. DTC B1342 also sets at this time.

When DTC B1342 is set because the module has reached a third threshold and the SJB has permanently disabled an output, no DTCs can be cleared from the SJB . Using the module self-test to confirm a repair is not possible and a measurement using a digital multimeter of the affected output circuit is required to make sure the fault condition no longer exists.

This pinpoint test is intended to diagnose the following:

- Output circuit short
- SJB

PINPOINT TEST A : DTCS B106E, B106F

A1 REVIEW THE DTCS	
NOTICE: First follow the necessary diagnostics to resolve DTC B106E and any other present DTCs (ignoring B106F). DTC B106E is only present when there is another DTC due to software or circuitry issues that must be resolved before another self-test is run. DTC B106F is only present once the final threshold has been met. Failure to correct the fault condition first may cause damage to the new <u>SJB</u> , resulting in a repeat repair.	
• Review the DTCs from the <u>SJB</u> self-test.	
Are any other DTCs present, besides B106E, B106F or B1342?	
Yes	CORRECT the DTCs. REFER to the Smart Junction Box (SJB) DTC chart in this section. After the repair, GO to A2 .
No	GO to A2 .

A2 REPEAT THE SJB SELF-TEST	
<ul style="list-style-type: none"> • Ignition ON. • Enter the following diagnostic mode on the scan tool: <u>SJB</u> Self-Test . • Clear the DTCs and repeat the <u>SJB</u> self-test. 	
Is DTC B106F or DTC B1342 present?	
Yes	INSTALL a new <u>SJB</u> . REFER to Smart Junction Box (SJB) in this section. TEST the system for normal operation.
No	The system is operating correctly at this time. The circuit short has been repaired.

Pinpoint Test B: DTC B1317

Refer to Wiring Diagrams Cell [13](#), Power Distribution/SJB for schematic and connector information.

Normal Operation

- DTC B1317 (Battery Voltage High) — a continuous memory DTC that sets when the SJB detects battery voltage above 15 volts.

This pinpoint test is intended to diagnose the following:

- Charging system concern
- SJB

PINPOINT TEST B : DTC B1317

NOTE: DTC B1317 may be stored in the module memory due to previous battery charging or vehicle jump starting events.

B1 CHECK FOR DTCS B1317, B1676 OR P0563 SET IN OTHER MODULES

- Ignition ON.
- Enter the following diagnostic mode on the scan tool: Self-Test .
- Retrieve the continuous memory DTCs from all modules.

Is DTC B1317, B1676 or P0563 (PCM) set in more than one module?

Yes	REFER to Section 414-00 to diagnose an overcharging condition.
No	GO to B2 .

B2 CHECK THE BATTERY VOLTAGE

- Turn off all interior/exterior lights and accessories.
- Start and run the engine at approximately 2,000 rpm for 3 minutes while monitoring the battery voltage.

Does the battery voltage rise to 15 volts or higher?

Yes	REFER to Section 414-00 to diagnose an overcharging condition.
No	GO to B3 .

B3 RECHECK FOR DTC B1317

- Turn the engine off.
- Ignition ON.
- Enter the following diagnostic mode on the scan tool: SJB Self-Test .
- Clear the continuous memory DTCs.
- Carry out the SJB self-test.

Is DTC B1317 present?

Yes	INSTALL a new <u>SJB</u> . REFER to Smart Junction Box (SJB) in this section. TEST the system for normal operation.
No	The system is operating normally at this time. The DTC may have been set previously during battery charging or while jump starting the vehicle.

Pinpoint Test C: DTC B1318

Refer to Wiring Diagrams Cell [13](#), Power Distribution/SJB for schematic and connector information.

Normal Operation

- DTC B1318 (Battery Voltage Low) — a continuous memory DTC that sets when the SJB detects battery voltage below 10 volts.

This pinpoint test is intended to diagnose the following:

- Wiring, terminals or connectors
- High circuit resistance
- SJB

PINPOINT TEST C : DTC B1318

NOTICE: Use the correct probe adapter(s) when making measurements. Failure to use the correct probe adapter(s) may damage the connector.

NOTE: Failure to disconnect the battery when instructed results in false resistance readings. Refer to [Section 414-01](#).

C1 RECHECK THE SJB DTCS

- Ignition ON.
- Enter the following diagnostic mode on the scan tool: [SJB Self-Test](#) .
- Clear the DTCs. Repeat the [SJB](#) self-test.

Is DTC B1318 still present?

Yes	GO to C2 .
No	The system is operating normally at this time. The DTC may have been set due to a previous low battery voltage condition.

C2 CHECK FOR CHARGING SYSTEM DTCS IN THE PCM

- Enter the following diagnostic mode on the scan tool: PCM Self-Test .
- Carry out the PCM [KOEO](#) self-test.
- Retrieve the continuous memory DTCs from the PCM.

Is DTC P0562, P0620, P0622, P0625, P0626 or P065B set in the PCM?

Yes	REFER to Section 414-00 .
No	GO to C3 .

C3 CHECK THE BATTERY CONDITION AND STATE OF CHARGE

- Ignition OFF.
- Check the battery condition and verify the battery is fully charged. Refer to [Section 414-01](#).

Is the battery OK and fully charged?

Yes	GO to C4 .
No	REFER to Section 414-00 .

C4 CHECK THE SJB VOLTAGE PID

- Ignition ON.
- Measure and record the voltage at the battery.
- Enter the following diagnostic mode on the scan tool: [SJB DataLogger](#) .
- Monitor the [SJB](#) voltage PID (GEM_VBAT).

Is the voltage within 0.2 volt of the recorded battery voltage?

Yes	GO to C7 .
No	GO to C5 .

C5 CHECK THE SJB VOLTAGE SUPPLY

- Ignition OFF.
- Disconnect: [SJB C2280G](#) .
- Ignition ON.
- Measure the voltage between the [SJB C2280G](#) Pin 1, circuit SBB01 (RD), harness side and ground.

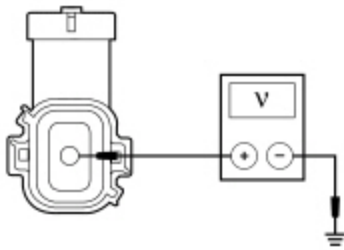

N0082086

Is the voltage within 0.2 volt of the recorded battery voltage?

Yes	GO to C6 .
No	REPAIR circuit SBB01 (RD) for high resistance. CLEAR the DTC. REPEAT the self-test.

C6 CHECK THE SJB GROUND CIRCUIT FOR HIGH RESISTANCE

- Ignition OFF.
- Disconnect: Negative Battery Cable .
- Disconnect: [SJB C2280D](#) .
- Measure the resistance between the [SJB](#) and ground as follows:

SJB Connector-Pin	Circuit
C2280D Pin 7	GD133 (BK)
C2280D Pin 8	GD139 (BK/YE)
C2280D Pin 12	GD139 (BK/YE)
C2280D Pin 24	GD139 (BK/YE)

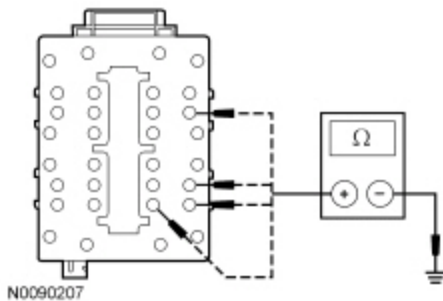

N0090207

Are the resistances less than 5 ohms?

Yes	GO to C7 .
No	REPAIR the ground circuit in question for high resistance. CLEAR the DTC. REPEAT the self-test.

C7 CHECK FOR CORRECT SJB OPERATION

- Disconnect the [SJB](#) connectors.
- Check for:
 - corrosion
 - damaged pins
 - pushed-out pins
- Connect the [SJB](#) connectors and make sure they seat correctly.
- Operate the system and verify the concern is still present.

Is the concern still present?

Yes	INSTALL a new <u>SJB</u> . REFER to Smart Junction Box (SJB) in this section. TEST the system for normal operation.
No	The system is operating correctly at this time. The concern may have been caused by a loose or corroded connector.

Pinpoint Test D: DTC U0155

Normal Operation

- DTC U0155 (Lost Communication With Instrument Panel Cluster (IC) Control Module) — a continuous DTC that sets when the SJB does not receive messaged data (loses communication) from the Instrument Panel Cluster (IPC) for longer than 5 minutes.

This pinpoint test is intended to diagnose the following:

- Communication network concern
- SJB
- IPC

PINPOINT TEST D : DTC U0155

D1 VERIFY CUSTOMER CONCERN

- Ignition ON.
- Verify that there is an observable symptom present.

Is an observable symptom present?

Yes	GO to D2 .
No	The system is operating normally at this time. The DTC may have been set due to high network traffic or an intermittent fault condition.

D2 CHECK THE COMMUNICATION NETWORK

- Ignition ON.
- Enter the following diagnostic mode on the scan tool: Network Test .
- Carry out the network test.

Does the IPC pass the network test?

Yes	GO to D3 .
No	REFER to Section 418-00 , The <u>IPC</u> Does Not Respond To The Scan Tool.

D3 RETRIEVE THE RECORDED DTCS FROM THE SJB SELF-TEST

- Check for recorded SJB DTCs from the self-test.

Is DTC B1317 or DTC B1318 recorded?

Yes	For DTC B1317, GO to Pinpoint Test B . For DTC B1318, GO to Pinpoint Test C .
No	GO to D4 .

D4 RECHECK THE SJB DTCS

NOTE: If new modules were installed prior to the DTC being set, the module configuration may be incorrectly set during Programmable Module Installation (PMI) or the PMI may not have been carried out.

- Clear the DTCs. Repeat the [SJB](#) self-test.

Is DTC U0155 still present?

Yes	GO to D5 .
No	The system is operating correctly at this time. The DTC may have been set due to high network traffic or an intermittent fault condition.

D5 CHECK FOR DTC U0155 SET IN OTHER MODULES

- Clear the DTCs.
- Ignition OFF.
- Ignition ON.
- Wait 10 seconds.
- Enter the following diagnostic mode on the scan tool: Self-Test .
- Retrieve the continuous memory DTCs from all modules.

Is DTC U0155 set in any other module?

Yes	INSTALL a new IPC. Refer to the appropriate Removal and Installation procedure in Section 413-01.
No	INSTALL a new SJB . REFER to Smart Junction Box (SJB) in this section.