

FORD:
2011-2012 Mustang

ISSUE

Some 2011-2012 Mustang vehicles equipped with a manual transmission may exhibit a squeak or creak noise from the clutch pedal during actuation.

ACTION

Follow the Service Procedure steps to correct the condition.

SERVICE PROCEDURE

Lubricate both the assist spring pivot shafts and the main pedal pivot shaft using Motorcraft Silicone Spray Lubricant. (Figure 1)

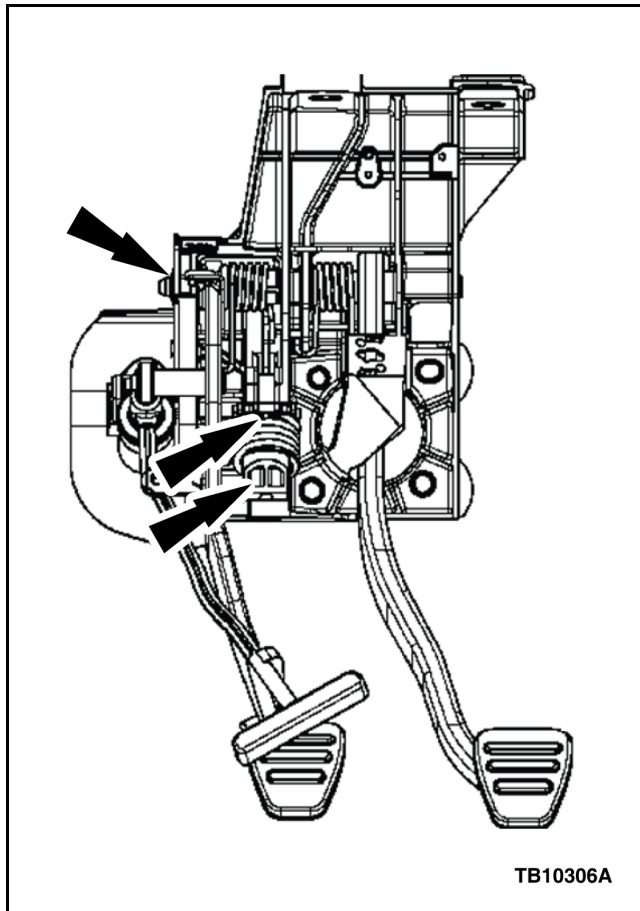

Figure 1 - Article 12-6-11

PART NUMBER	PART NAME
XL-6	Motorcraft® Silicone Spray Lubricant

WARRANTY STATUS: Eligible Under Provisions Of New Vehicle Limited Warranty Coverage. Warranty/ESP coverage limits/policies/prior approvals are not altered by a TSB. Warranty/ESP coverage limits are determined by the identified causal part and verified using the OASIS part coverage tool.

OPERATION	DESCRIPTION	TIME
120611A	2011-2012 Mustang: Lubricate The Assist Spring Pivot Shafts And The Main Pedal Pivot Shaft (Do Not Use With Any Other Labor Operations)	0.2 Hr.

DEALER CODING	CONDITION CODE
BASIC PART NO. 2455	42

NOTE: The information in Technical Service Bulletins is intended for use by trained, professional technicians with the knowledge, tools, and equipment to do the job properly and safely. It informs these technicians of conditions that may occur on some vehicles, or provides information that could assist in proper vehicle service. The procedures should not be performed by "do-it-yourselfers". Do not assume that a condition described affects your car or truck. Contact a Ford or Lincoln dealership to determine whether the Bulletin applies to your vehicle. Warranty Policy and Extended Service Plan documentation determine Warranty and/or Extended Service Plan coverage unless stated otherwise in the TSB article. The information in this Technical Service Bulletin (TSB) was current at the time of printing. Ford Motor Company reserves the right to supersede this information with updates. The most recent information is available through Ford Motor Company's on-line technical resources.