

The top of the boot will fit tightly on the machined groove on the upper portion of the Steeda shift lever, see #2

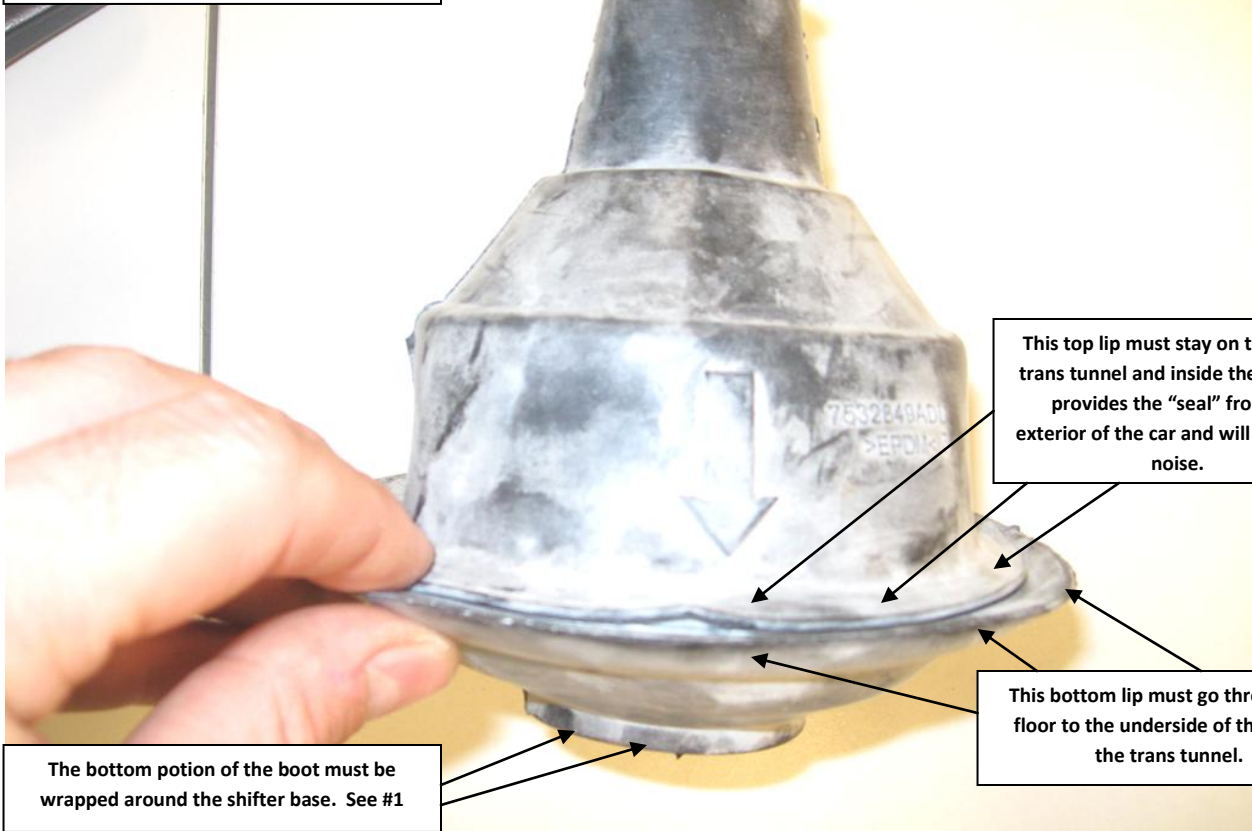

This top lip must stay on top of the trans tunnel and inside the car. This provides the "seal" from the exterior of the car and will eliminate noise.

This bottom lip must go through the floor to the underside of the car, in the trans tunnel.

The bottom portion of the boot must be wrapped around the shifter base. See #1

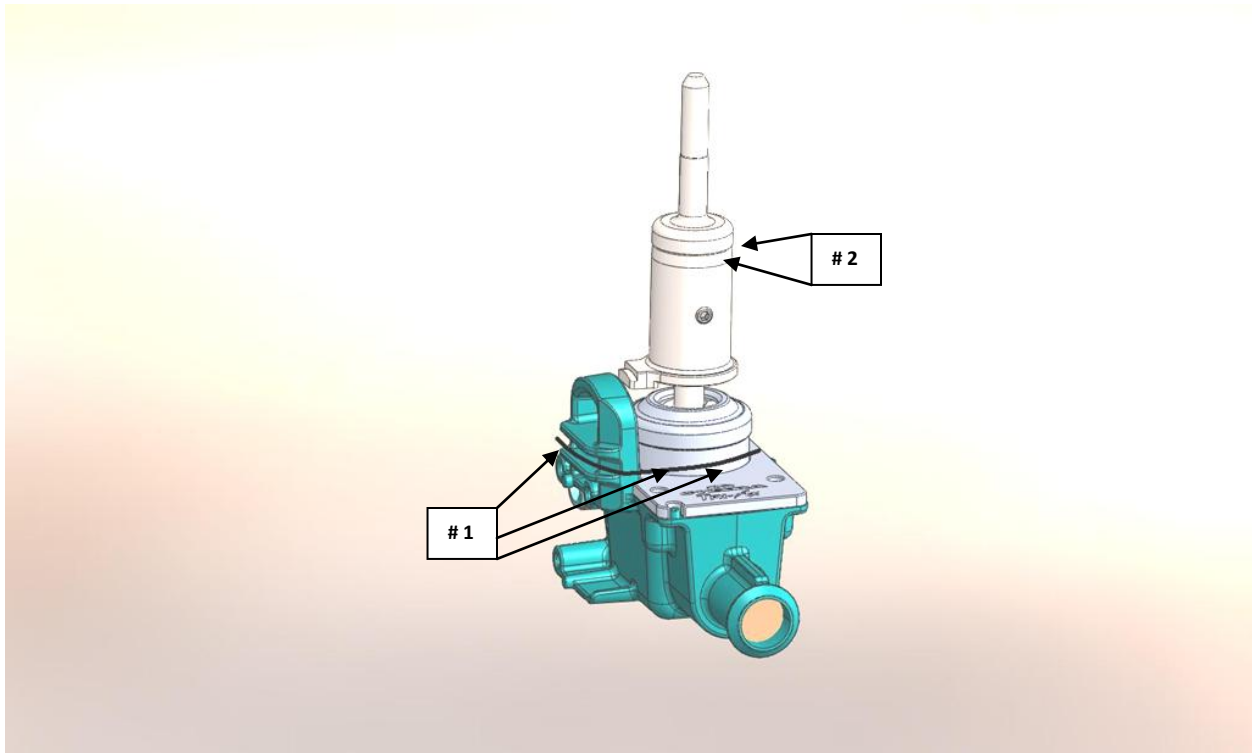

#1

#2