

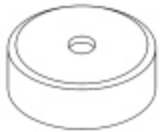

Differential Ring And Pinion

Special Tool(s)

 <p>ST2026-A</p>	<p>2 Jaw Puller 205-D072 (D79L-4221-A1) or equivalent</p>
 <p>ST1743-A</p>	<p>Adapter for 205-S127 205-105 (T76P-4020-A3)</p>
 <p>ST1429-A</p>	<p>Adapter for 205-S127 205-109 (T76P-4020-A9)</p>
 <p>ST1431-A</p>	<p>Adapter for 205-S127 205-110 (T76P-4020-A10)</p>
 <p>ST1432-A</p>	<p>Adapter for 205-S127 205-111 (T76P-4020-A11)</p>

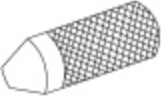
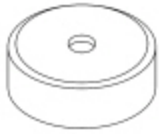

ST1743-A

Adapter for 205-S127
[205-125](#) (T78P-4020-A15)

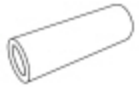

ST1434-A

Gauge Tube
[205-D034](#) (D80T-4020-F49) or equivalent



ST1375-A

Installer, Differential Side Bearing
[205-009](#) (T57L-4221-A1)



ST1367-A

Installer, Drive Pinion Bearing Cone
[205-005](#) (T53T-4621-C)



ST1678-A

Installer, Drive Pinion Bearing Cup
[205-054](#) (T71P-4616-A)

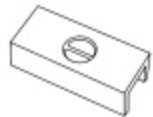

ST1254-A

Plate, Bearing/Oil Seal
[205-090](#) (T75L-1165-B)

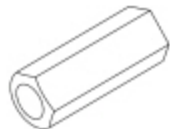

ST1744-A

Protector, Drive Pinion Thread
[205-460](#)



ST1543-A

Step Plate

[205-D016](#) (D80L-630-5) or equivalent

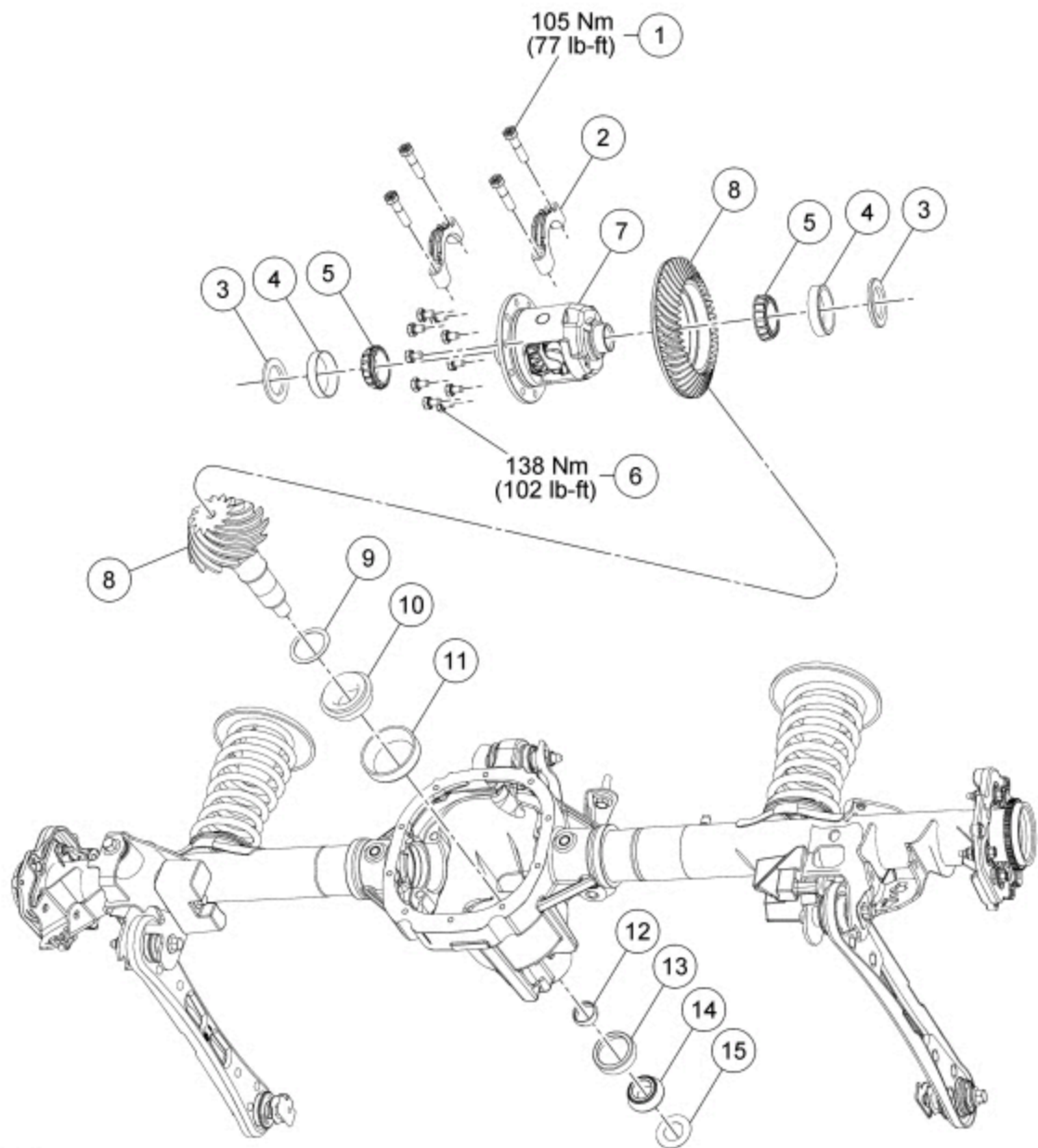

N0100475

Item	Part Number	Description
1	—	Differential bearing cap bolt (part of 4010)
2	—	Differential bearing cap (part of 4010)
3	4067	Differential bearing shims (2 required)

4	4221	Differential bearing cups (2 required)
5	4222	Differential bearing cones (2 required)
6	4216	Differential ring gear bolt (10 required)
7	—	Differential carrier assembly
8	4209	Ring gear (set with drive pinion)
9	4663	Pinion bearing adjustment shim
10	4630	Inner pinion bearing
11	4628	Inner pinion bearing cup
12	4662	Collapsible spacer
13	4616	Outer pinion bearing cup
14	4621	Outer pinion bearing
15	4670	Pinion oil slinger

Removal

1. Remove the differential carrier. For additional information, refer to [Differential Carrier](#) in this section.
2. Remove the drive pinion flange seal. For additional information, refer to [Drive Pinion Flange and Drive Pinion Seal](#) in this section.
3. Remove and discard the 10 differential ring gear bolts.

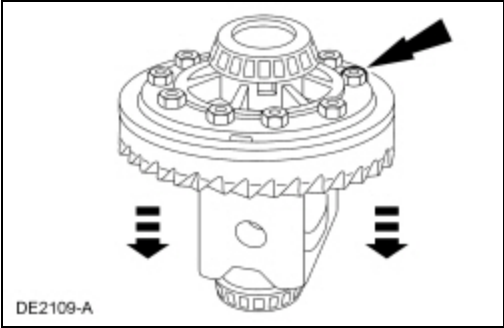

4. **NOTE:** Do not damage the differential ring gear bolt hole threads.
 Insert a punch in the differential ring gear bolt holes and drive the differential ring gear off.

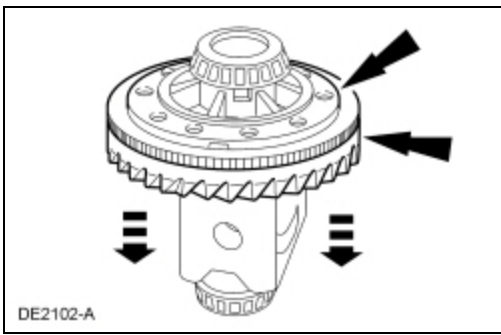

5. Using the 2 Jaw Puller and Step Plate, remove the differential bearings.

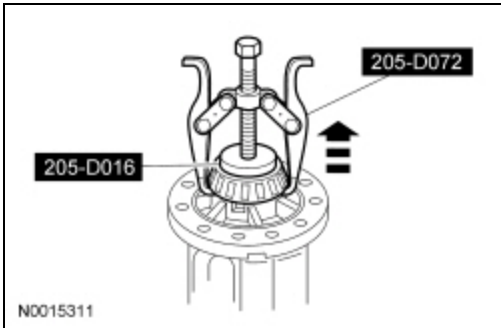

6. Remove the drive pinion shaft oil slinger and the outer drive pinion bearing.

7. Install the Drive Pinion Thread Protector. Using a soft-faced hammer, drive the pinion assembly out of the axle housing.

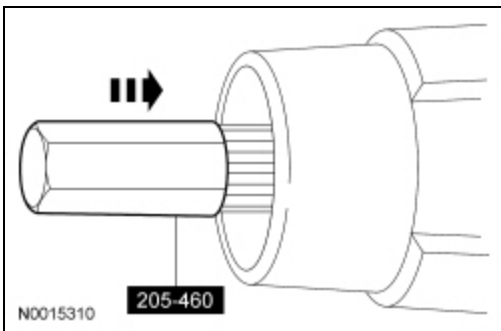

8. Remove and discard the drive pinion collapsible spacer.

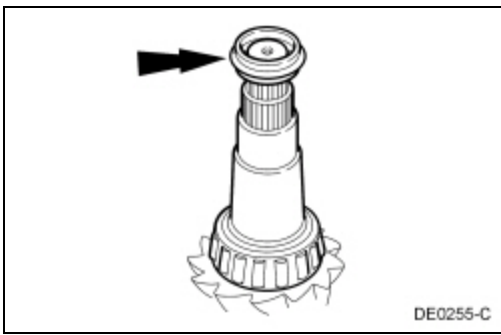

9. Using a brass drift, remove the drive pinion bearing cups by tapping alternately on opposite sides of the drive pinion bearing cups.

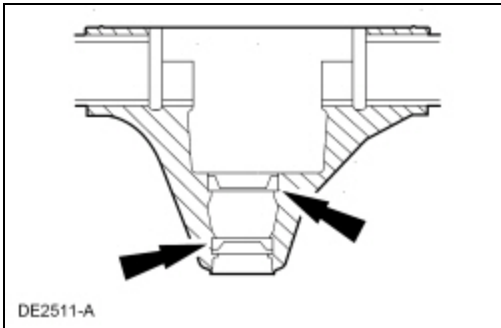

Installation

1. Position the Drive Pinion Bearing Cup Installer and the inner and outer drive pinion bearing cups in their respective bores.
 1. After placing the inner and outer drive pinion bearing cups in their bores, place the Drive Pinion Bearing Cup Installer (inner) on the inner drive pinion bearing cup.
 2. Place the Drive Pinion Bearing Cup Installer (outer) on the outer drive pinion bearing cup.
 3. Install the Drive Pinion Bearing Cup Installer.

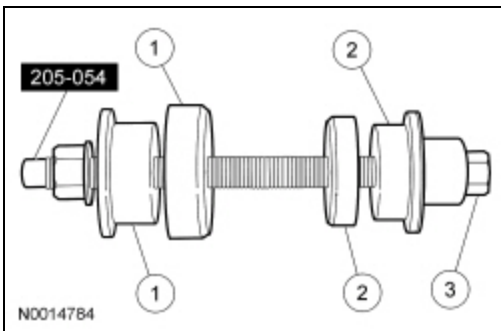

2. Tighten the Drive Pinion Bearing Cup Installer to seat the drive pinion bearing cups into their bores.

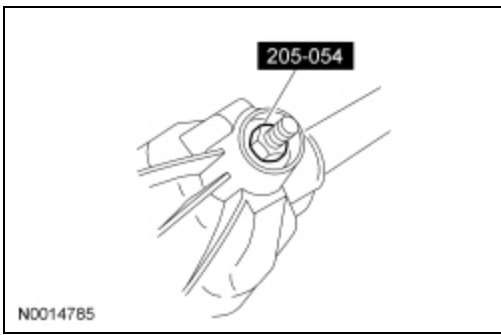

3. **NOTE:** *If a feeler gauge can be inserted between a drive pinion bearing cup and the bottom of its bore at any point around the drive pinion bearing cup, the drive pinion bearing cup is not correctly seated.*

Make sure the drive pinion bearing cups are correctly seated in their bores.

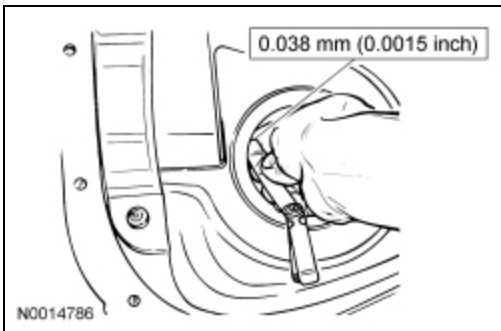

4. **NOTE:** *Install new drive pinion bearings without any additional lubricant since the anti-rust oil provides adequate lubricant without upsetting the drive pinion bearing preload settings.*

Assemble and position the Adapters in the sequence shown.

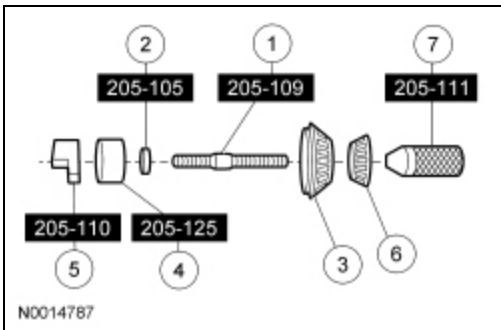

5. **NOTE:** *This step duplicates final drive pinion bearing preload.*

Tighten the Adapter.

- Tighten to 2.2 Nm (20 lb-in).

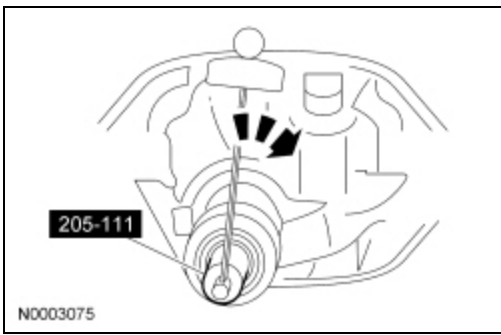

6. **NOTE:** *The Adapter must be offset to obtain an accurate reading.*

Rotate the Adapter several half-turns to make sure of correct seating of the drive pinion bearings.

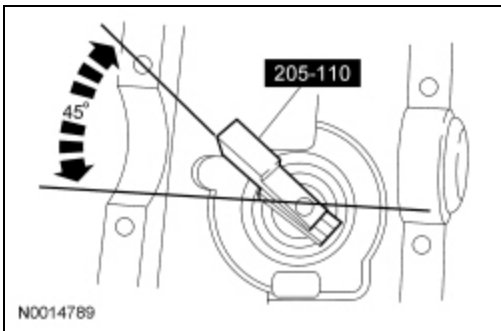

7. Install the Gauge Tube.

1. Position the Gauge Tube.
2. Install the 2 differential bearing caps.
3. Install the 4 differential bearing cap bolts.
 - Tighten to 105 Nm (77 lb-ft).

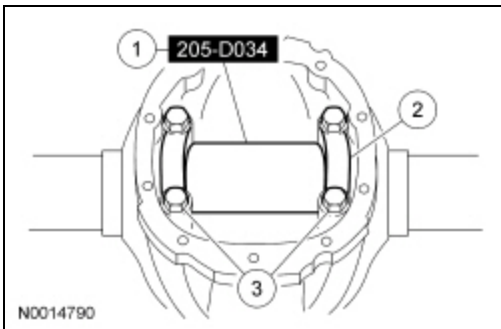

8. **NOTE:** *Drive pinion bearing adjustment shims must be flat and clean.*

NOTE: *A slight drag should be felt for correct drive pinion bearing adjustment shim selection. Do not attempt to force the drive pinion bearing adjustment shim between the gauge block and the Gauge Tube. This will minimize selection of a drive pinion bearing adjustment shim thicker than required, which results in a deep tooth contact in final assembly of integral axle assemblies.*

Use a drive pinion bearing adjustment shim as a gauge for drive pinion bearing adjustment shim selection.

- After the correct drive pinion bearing adjustment shim thickness has been determined, remove all of the Adapters.

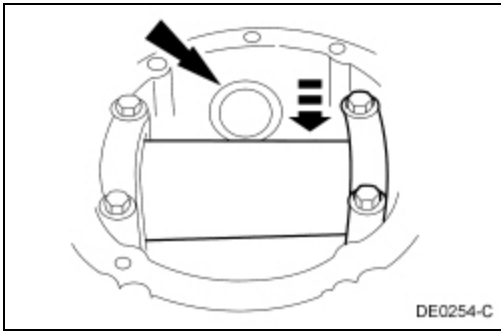

9. Using the Drive Pinion Bearing Cone Installer and Bearing/Oil Seal Plate, press the inner drive pinion bearing and drive pinion bearing adjustment shim until it is firmly seated on the pinion shaft.

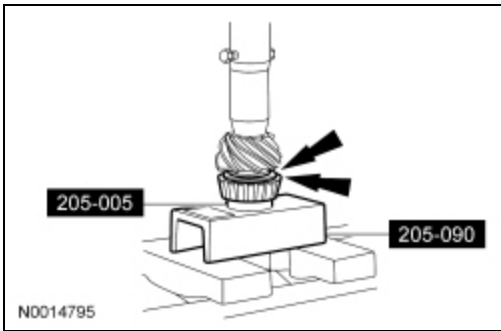

10. Install a new drive pinion collapsible spacer on the pinion shaft against the pinion shaft shoulder.

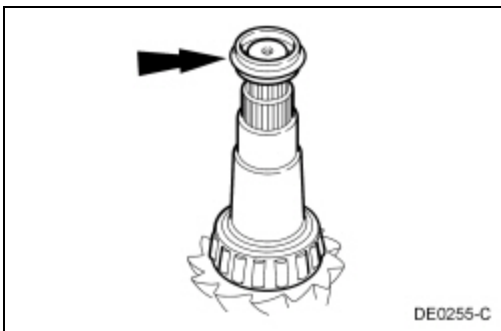

11. Install the outer drive pinion bearing and the drive pinion shaft oil slinger.

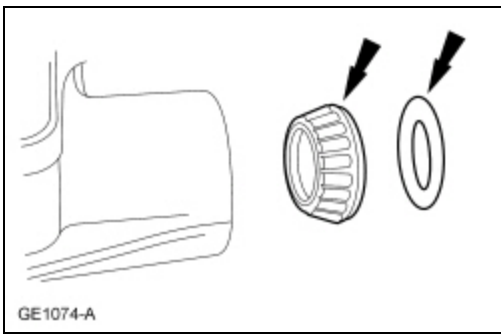

12. Position the drive pinion assembly into the axle housing.

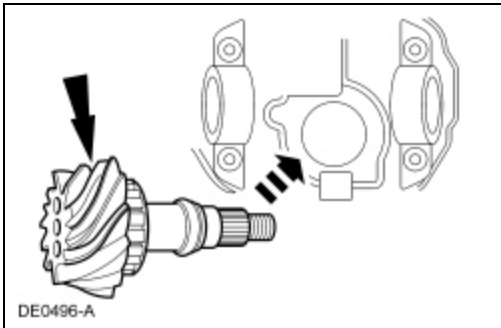

13. Using the Differential Side Bearing Installer, install the 2 new differential bearings.

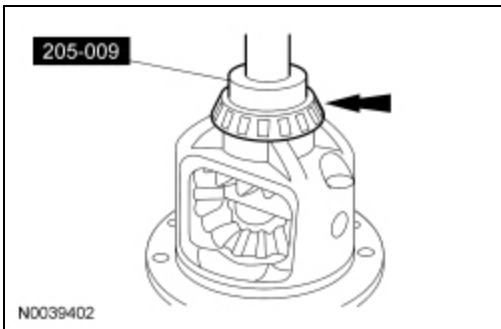

14. Press the differential ring gear on the differential assembly.

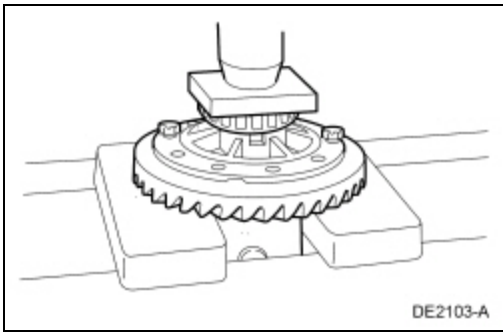

15. Install the 10 new differential ring gear bolts.
- Tighten to 138 Nm (102 lb-ft).

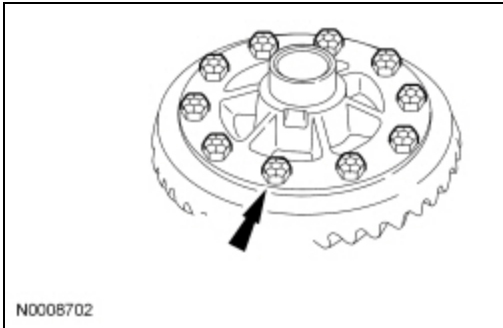

16. Install the drive pinion seal and flange. For additional information, refer to [Drive Pinion Flange and Drive Pinion Seal](#) in this section.
17. Install the differential carrier. For additional information, refer to [Differential Carrier](#) in this section.