





Transmission Fluid Level Check

Special Tool(s)

 ST2467-A	Rubber Tip Air Nozzle 100-D009 (D93L-7000-A)
 ST1269-A	Vacuum Pump Kit 416-D002 (D95L-7559-A)
 ST2715-A	Fluid Transporter/Evacuator/Injector 307-D465
 ST2332-A	Worldwide Diagnostic System (WDS) Vehicle Communication module (VCM) with appropriate adapters, or equivalent diagnostic tool
 ST2951-A	Adapter, Fluid Level and Fill Plug 307-437

Material

Item	Specification
MERCON® V Automatic Transmission Fluid XT-5-QM	MERCON® V

Fluid Fill Reference

NOTE: Left side of case shown.

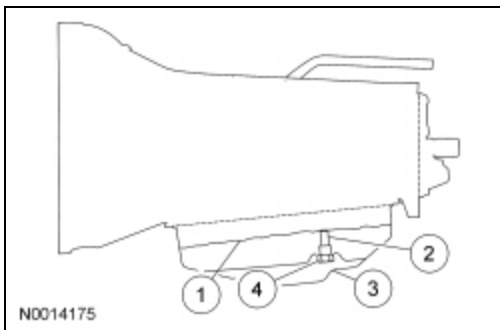

Item	Part Number	Description
1	—	Fluid level
2	7A010	Fluid level tube
3	W704999 -S309	Fluid level and fill plug (small) (in-vehicle)
4	7A010	Fluid drain plug (large)

- Using the diagnostic tool, monitor the transmission fluid temperature (TFT) using PID: TFT.
- Start the vehicle.
- NOTE:** Engine idle speed is approximately 650 rpm.

While proceeding with this procedure, run the engine until the transmission fluid temperature is between 27°-49°C (80°-120°F).

4. Move the range selector lever slowly through each gear, stopping in each position and allowing the transmission to engage.

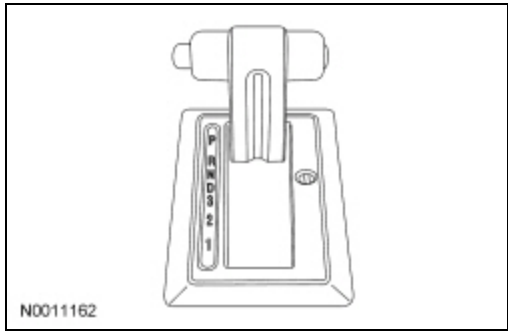

5. Place the range selector lever in the PARK position.
6. With the engine running, position the vehicle on a hoist and set it as close to level as possible. For additional information, refer to [Section 100-02](#).
7. Hold the larger drain plug with a wrench and remove the small (center) fluid level indicating plug.

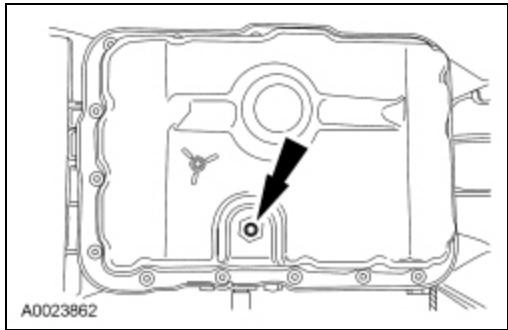

8. Install the special tool into the pan.

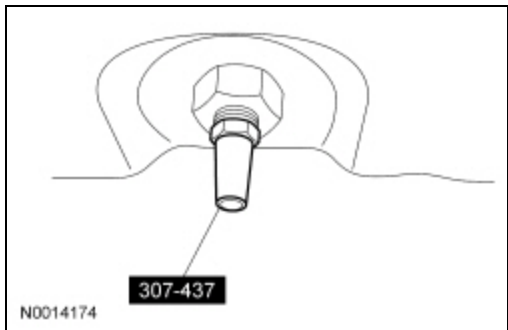

9. **NOTE:** Prior to filling the special tool with clean transmission fluid, make sure that the canister is clean.

Fill the special tool with clean automatic transmission fluid.

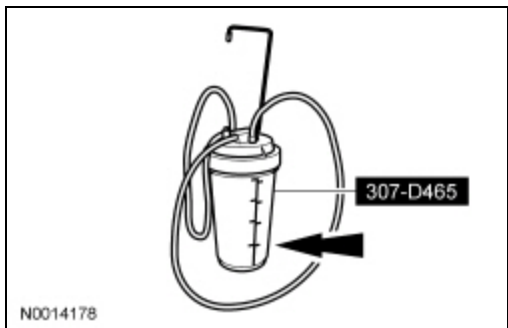

10. Hang the special tool under the vehicle. Position it upright and close to the transmission.

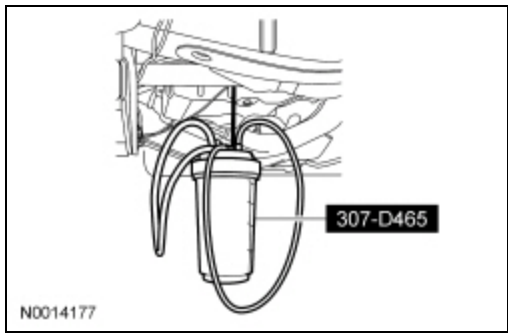

11. Connect the special tools.

- Connect the open end of the fluid hose from the Fluid Transporter/Evacuator/Injector to the Fluid Level and Fill Plug Adapter at the bottom of the transmission fluid pan.

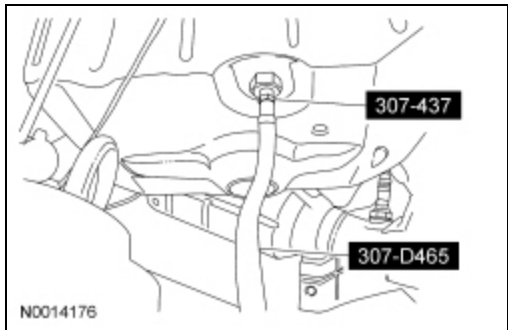

12. Apply a maximum of 206.85 kPa (30 psi) to the open end of the vacuum/pressure hose from the special tool. Fluid will immediately start flowing out of the special tool into the transmission fluid pan.

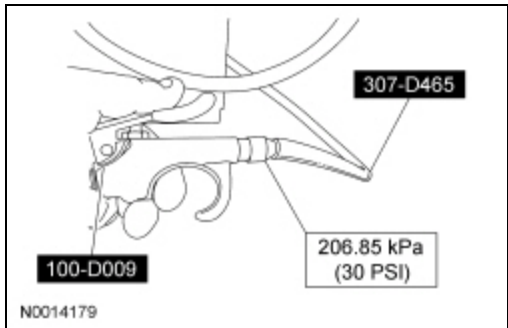

13. Add one pint of transmission fluid into the fluid pan. Stop the process by releasing the air pressure and removing the air nozzle from the end of the hose.

14. Inspect the fluid level in the special tool. If the fluid drains back into the canister, the transmission is full. If no fluid drains back, more fluid will need to be added. Repeat Steps 12 and 13.

15. Once the transmission is full, place a hand vacuum pump on the open end of the vacuum/pressure hose of the special tool and apply vacuum to the system. This will pull out any extra fluid trapped in the system and direct it into the container.

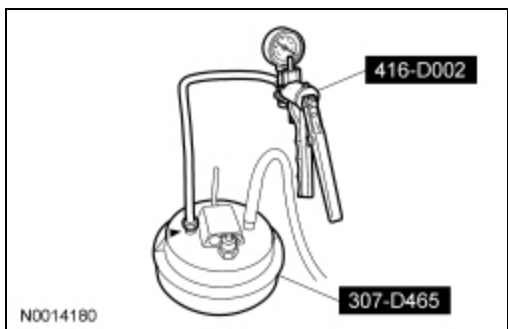

16. Allow the fluid to drain. Make sure that the fluid temperature is between 27°-49°C (80°-120°F). When the fluid comes out as a thin stream or drip, the fluid is at the correct level.

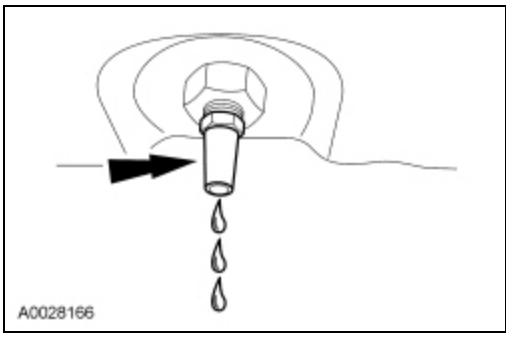

17. Reinstall the small (center) fluid level indicating plug and tighten to 10 Nm (89 lb-in).

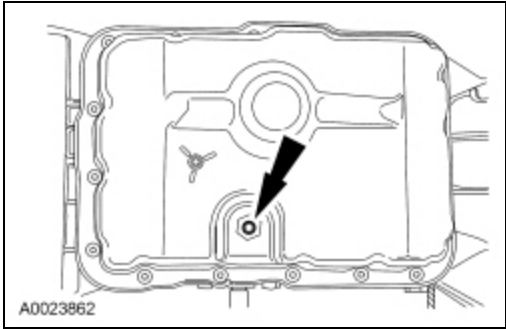

18. Check the operation of the transmission by moving the range selector lever slowly through each gear, stopping in each position and allowing the transmission to engage.