





Transmission Fluid Drain and Refill — Without Torque Converter Drain Plug

Special Tool(s)

	Rubber Tip Air Nozzle 100-D009 (D93L-7000-A)
	Vacuum Pump Kit 416-D002 (D95L-7559-A)
	Fluid Transporter/Evacuator/ Injector 307-D465
	Adapter, Fluid Level and Fill Plug 307-437
	Worldwide Diagnostic System (WDS) Vehicle Communication module (VCM) with appropriate adapters, or equivalent diagnostic tool

Material

Item	Specification
MERCON® V Automatic Transmission Fluid XT-5-QM	MERCON® V

Fluid Fill Reference

NOTE: Left side of case is shown.

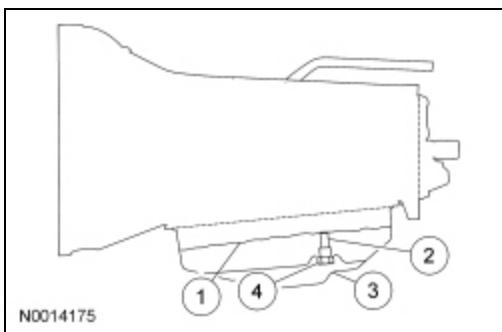

Item	Part Number	Description
1	—	Fluid level
2	7A010	Fluid level tube
3	W704999-S309	Fluid level and fill plug (small) (in-vehicle)
4	7A010	Fluid drain plug (large)

Draining

1. With the vehicle in NEUTRAL, position it on a hoist. Set the vehicle as close to level as possible. For additional information, refer to [Section 100-02](#).

2. Remove the drain plug (large plug) and allow the fluid to drain.

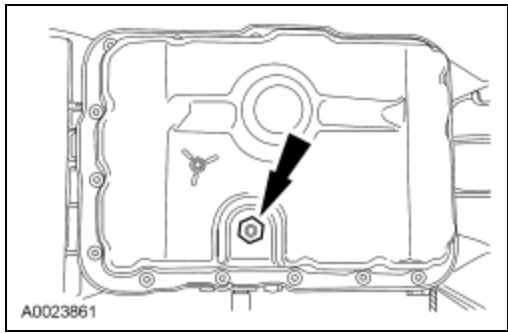

Filling

1. Install the fluid drain plug.
 - Tighten to 26 Nm (19 lb-ft).

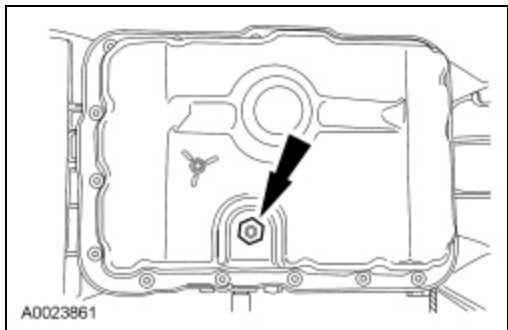

2. Hold the larger drain plug with a wrench and remove the small (center) fluid level indicating plug.

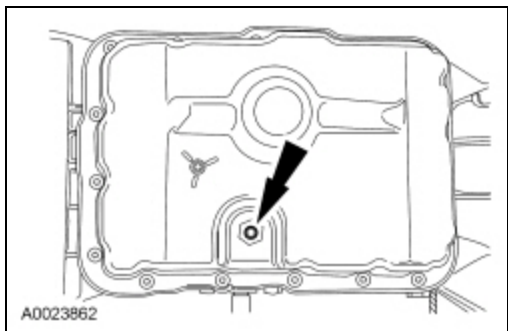

3. Install the special tool into the pan.

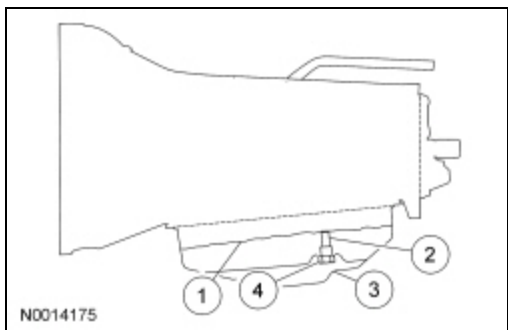

4. **NOTE:** Prior to filling the special tool with clean transmission fluid, make sure that the canister is clean.

Fill the special tool with clean automatic transmission fluid.

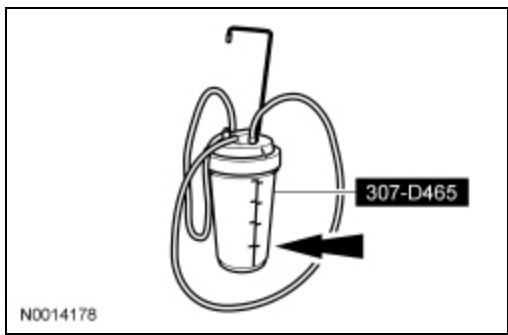

5. Hang the special tool under the vehicle, upright and close to the transmission.

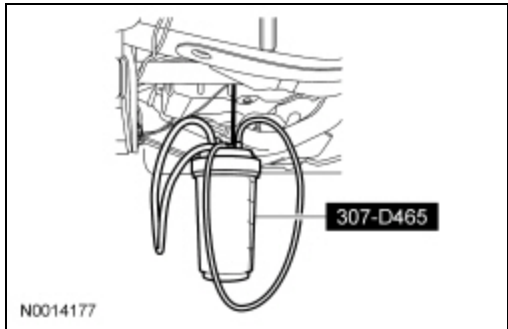

6. Connect the special tools.

- Connect the open end of the fluid hose from the Fluid Transporter/Evacuator/Injector to the Adapter, Fluid Level and Fill Plug at the bottom of the transmission fluid pan.

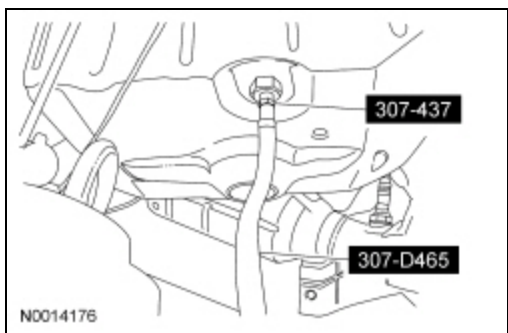

7. Apply a maximum of 206.85 kPa (30 psi) to the open end of the vacuum/pressure hose from the special tool. Fluid will immediately start flowing out of the special tool into the transmission fluid pan.

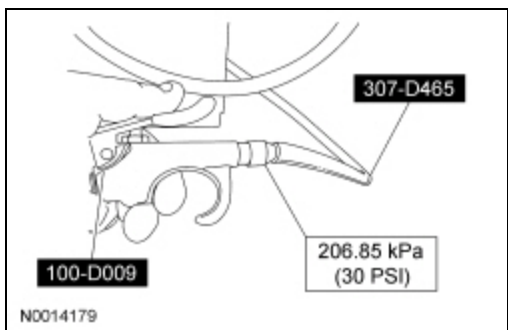

8. Add 2 or 3 quarts of transmission fluid into the fluid pan. Stop the process by releasing the air pressure and removing the air nozzle from the end of the hose.

9. **NOTE:** Engine idle speed is approximately 650 rpm.

Start and run the engine until the transmission fluid temperature is between 27°-49°C (80°-120°F).

10. Inspect the fluid level in the special tool. If the fluid drains back into the canister, the transmission is full. If no fluid drains back, more fluid will need to be added. Repeat Steps 8 and 9.

11. Once the transmission is full, place a hand vacuum pump on the open end of the vacuum/pressure hose of the special tool and apply vacuum to the system. This will pull out any extra fluid trapped in the system and direct it into the container.

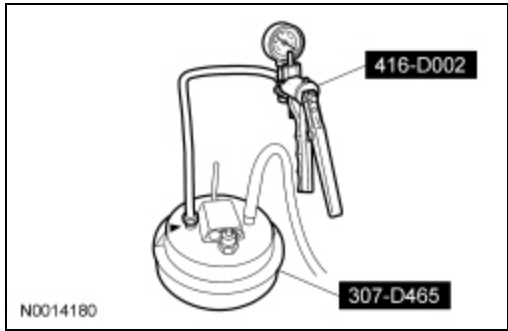

12. Allow the fluid to drain. When the fluid comes out as a thin stream or drip, the fluid is at the correct level.

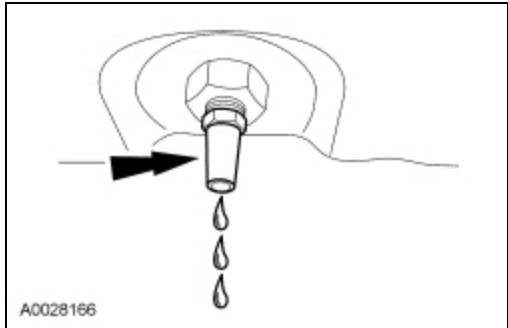

13. Reinstall the small (center) fluid level indicating plug using a 3/16-inch Allen key.
- Tighten to 10 Nm (89 lb-in).

