







Climate Control System

Special Tool(s)

 ST2085-A	A/C Flush Adapter Kit 219-00074 or equivalent
 ST2574-A	Flex Probe Kit 105-R025C or Equivalent
 ST1137-A	Fluke 77 III Automotive Meter 105-R0056 or equivalent
 ST1474-A	Pressure Test Kit 014-R1072 or equivalent
 ST1928-A	R-134a Manifold Gauge Set 176-R032A or equivalent
 ST2351-A	Refrigerant Leak Detector 216-00001 or equivalent
 ST2834-A	Vehicle Communication Module (VCM) and Integrated Diagnostic System (IDS) software with appropriate hardware, or equivalent scan tool

Principles of Operation

Compressor Anti-Slugging Strategy (CASS)

Liquid refrigerant may accumulate in the A/C compressor under certain conditions. To alleviate damage to the A/C compressor, Compressor Anti-Slugging Strategy (CASS) is utilized.

CASS is initiated only under specific conditions:

- When the ignition is OFF for more than 8 hours
- When the ambient temperature is above -4°C (25°F)
- When battery voltage is above 8.5 volts during engine cranking

When these conditions are present, the PCM will activate the A/C control relay prior to cranking of the engine. The A/C control relay engages the A/C compressor for approximately 4-15 A/C compressor revolutions or a maximum of 2 seconds (depending upon vehicle application), allowing the liquid refrigerant to be pushed from the A/C compressor. CASS is initiated by the PCM regardless of the function selector switch position or the HVAC system settings.

The Refrigerant Cycle

During stabilized conditions (A/C system shutdown), the refrigerant is in a vaporized state and pressures are equal throughout the system. When the A/C compressor is in operation, it increases pressure on the refrigerant vapor, raising its temperature. The high-pressure and high-temperature vapor is then released into the top of the condenser core.

The condenser core, being close to ambient temperature, causes the refrigerant vapor to condense into a liquid when heat is removed by ambient air passing over the fins and tubing. The now liquid refrigerant, still at high pressure, exits from the bottom of the condenser core and enters the inlet side of the evaporator core orifice.

The evaporator core orifice is the restriction in the refrigerant system that creates the low-pressure drop in the evaporator core and separates the high- and low-pressure sides of the A/C system. As the liquid refrigerant leaves this restriction, its pressure and boiling points are reduced.

The liquid refrigerant is now at its lowest pressure and temperature. As it passes through the evaporator core, it absorbs heat from the passenger compartment airflow passing over the plate/fin sections of the evaporator core. This addition of heat causes the refrigerant to boil (convert to gas). The now cooler passenger compartment air can no longer support the same humidity level of the warmer air and this excess moisture condenses on the exterior of the evaporator coils and fins and drains outside the vehicle.

The suction accumulator is designed to remove moisture from the refrigerant and to prevent any liquid refrigerant that may not have been vaporized in the evaporator core from reaching the A/C compressor. The A/C compressor is designed to pump refrigerant vapor only, as liquid refrigerant will not compress and can damage the A/C compressor.

The refrigerant cycle is now repeated with the A/C compressor again increasing the pressure and temperature of the refrigerant.

The A/C cycling switch interrupts compressor operation before the external temperature of the evaporator core gets low enough to cause the condensed water vapor (excess humidity) to turn to ice. It does this by monitoring low side line pressure. It is known that a refrigerant pressure of approximately 210 kPa (30 psi) will yield an operating temperature of 0°C (32°F). The A/C cycling switch controls system operation in an effort to maintain this temperature.

The high side line pressure is also monitored so that A/C compressor operation can be interrupted if system pressure becomes too high. When the A/C compressor discharge pressure rises, the A/C dual-function pressure switch contacts open (4.6L and 5.4L) or the A/C pressure transducer value changes (4.0L), disengaging the A/C compressor. When the pressure drops, operation of the A/C compressor resumes.

The A/C pressure relief valve will open and vent refrigerant to relieve unusually high system pressure.

Clutch Cycling Orifice Tube Type Refrigerant System

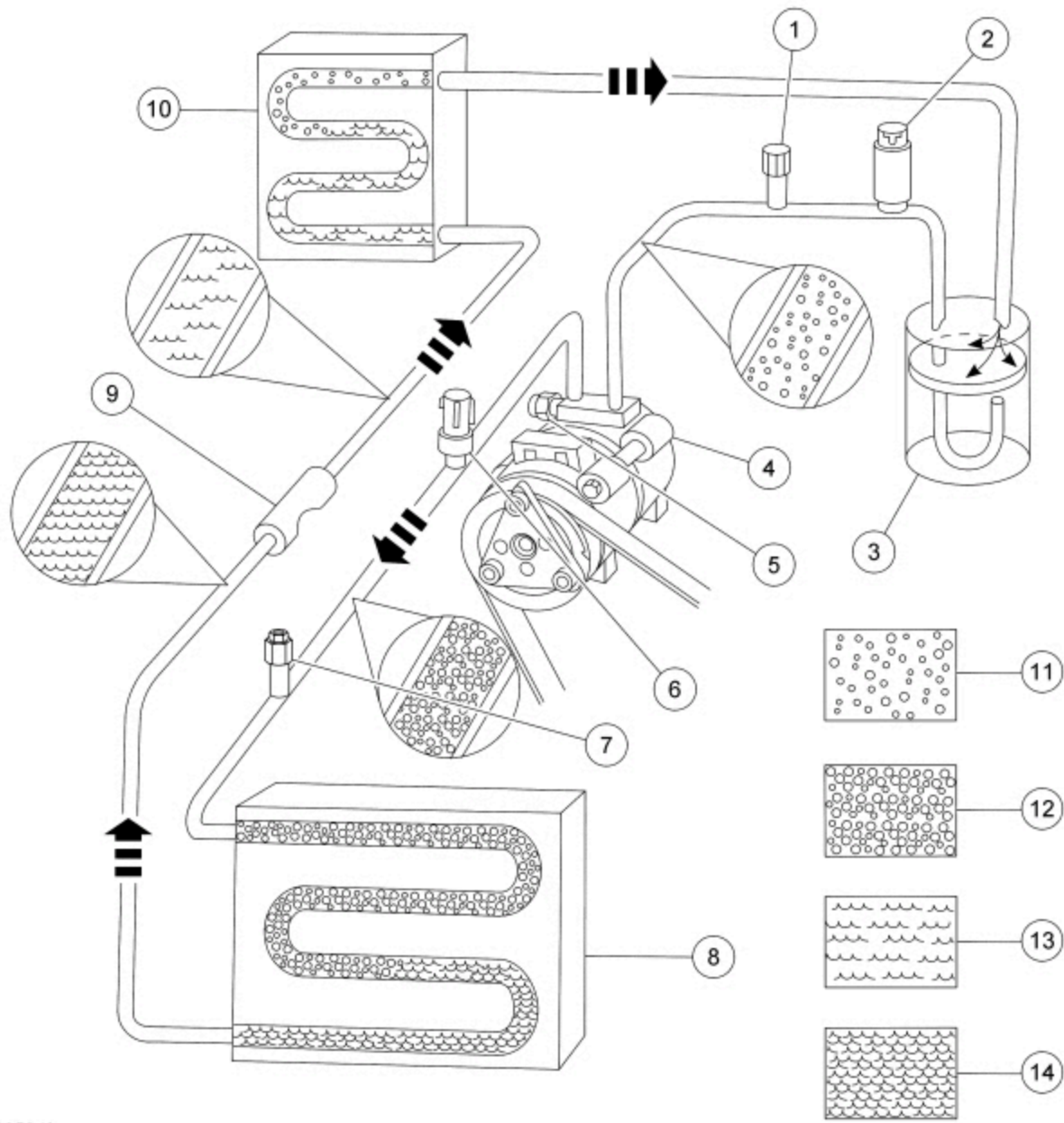

N0065049

Item	Description
1	A/C charge valve port (low side)
2	A/C cycling switch
3	Suction accumulator

Item	Description
4	A/C compressor
5	A/C compressor pressure relief valve
6	A/C pressure transducer (4.0L)
6	A/C dual function pressure switch (4.6L and 5.4L)
7	A/C charge valve port (high side)
8	Condenser core
9	Evaporator core orifice tube
10	Evaporator core
11	Low-pressure vapor
12	High-pressure vapor
13	Low-pressure liquid
14	High-pressure liquid

Inspection and Verification

1. Verify the customer concern.
2. Visually inspect for obvious signs of mechanical or electrical damage.

Visual Inspection Chart

Mechanical	Electrical
<ul style="list-style-type: none"> • Loose, missing or damaged A/C compressor drive belt • Loose or disconnected A/C clutch • Broken or binding door/actuator • Broken or leaking refrigerant lines 	<ul style="list-style-type: none"> • Smart Junction Box (SJB) fuse(s): <ul style="list-style-type: none"> ▪ 3 (10A) ▪ 14 (5A) ▪ 19 (5A) ▪ 10 (5A) ▪ 12 (5A) • Bussed Electrical Center (BEC) fuse(s): <ul style="list-style-type: none"> ▪ 2 (30A) ▪ 47 (15A) ▪ 49 (15A) • Blower motor inoperative • A/C compressor inoperative • Circuitry open/shorted • Disconnected electrical connectors • Cooling fan inoperative

3. As pinpoint tests and measurements are being carried out, be sure to inspect for any disconnected, loose-fitting or incorrectly installed components, module and in-line electrical connectors and pins.

4. If the inspection reveals obvious concern(s) that can be readily identified, repair as required.

5. **NOTE:** *Make sure to use the latest scan tool software release.*

If the cause is not visually evident, connect the scan tool to the Data Link Connector (DLC) .

6. **NOTE:** *The Vehicle Communication Module (VCM) LED prove-out confirms power and ground from the DLC are provided to the VCM .*

If the scan tool does not communicate with the VCM :

- check the VCM connection to the vehicle.
- check the scan tool connection to the VCM .
- refer to [Section 418-00](#), No Power To The Scan Tool, to diagnose no power to the scan tool.

7. If the scan tool does not communicate with the vehicle:

- verify the ignition key is in the ON position.
- verify the scan tool operation with a known good vehicle.
- **NOTE:** *The Smart Junction Box (SJB) may also be referred to as a Generic Electronic Module (GEM) .*

Refer to [Section 418-00](#) to diagnose no response from the SJB or PCM.

8. Carry out the network test.

- If the scan tool responds with no communication from one or more modules, refer to [Section 418-00](#).
- If the network test passes, retrieve and record the continuous memory DTCs.

9. **NOTE:** *Some PCM DTCs may inhibit A/C operation. If any PCM DTCs are retrieved, diagnose those first. Refer to Powertrain Control/Emissions Diagnosis (PC/ED) manual.*

Clear the continuous DTCs and carry out the self-test diagnostics for the SJB or PCM.

10. If the SJB DTCs retrieved are related to the concern, refer to the Smart Junction Box (SJB) DTC Chart. If the PCM DTCs retrieved are related to the concern, refer to the PCM DTC Chart.

11. If no DTCs related to the concern are retrieved, GO to [Symptom Chart — Climate Control Systems](#) or GO to [Symptom Chart — NVH](#).

HVAC Module Cold Boot Process

The purpose of the cold boot process is to allow the HVAC module to reinitialize and calibrate the actuators. To carry out the cold boot process, follow the steps below.

1. Turn the ignition switch to the OFF position.

2. Disconnect the HVAC module electrical connectors.

3. Inspect the module connectors for:

- corrosion.
- pushed-out pins.
- incorrectly seated connector.

4. Wait one minute.

5. Connect the HVAC module electrical connectors.

6. Turn the ignition switch to the ON position.

7. Select any position except OFF on the HVAC module.

The HVAC module will now initialize and calibrate the actuators. Calibration of the actuators will take approximately 30 seconds.

Smart Junction Box (SJB) DTC Chart

DTC	Description	Action to Take
B2175	A/C Request Signal Circuit Short to Ground	GO to Pinpoint Test G.
All Other DTCs	—	REFER to the Master DTC Chart in Section 419-10.

PCM DTC Chart

DTC	Description	Action to Take
P0532	A/C Pressure Refrigerant Sensor A Circuit Low	GO to Pinpoint Test A.
P0533	A/C Refrigerant Pressure Sensor A Circuit High	GO to Pinpoint Test A.
P0645	Air Conditioning Clutch Relay (A/CCR) Control Circuit	GO to Pinpoint Test B.
P1464	A/C Demand Out Of Self Test Range	If the HVAC selector was not in the OFF position, place it in the OFF position, CLEAR the DTCs and REPEAT the self-test. If the DTC does not return, ignore the DTC and continue diagnostics. If the DTC returns, GO to Pinpoint Test H. ^a
All Other DTCs	—	REFER to Powertrain Control/Emissions Diagnosis (PC/ED) manual.

^aPCM DTC P1464 will set if the function selector is in PANEL with A/C button pressed, DEFROST or MAX A/C mode when the on-demand self-test is being run.

Symptom Chart — Climate Control Systems

Symptom Chart — Climate Control Systems

Condition	Possible Causes	Action
NOTE: Some PCM DTCs may inhibit A/C operation. If any PCM DTCs are retrieved, diagnose those first. Refer to the PCM DTC Chart		
• HVAC functions verification	• HVAC system and/or related components	• GO to Pinpoint Test K.
• The air inlet mode door is inoperative	• Circuitry short/open • HVAC module • Air inlet mode door actuator/linkage	• GO to Pinpoint Test C.

<ul style="list-style-type: none"> • Incorrect/erratic direction of airflow from outlet(s) 	<ul style="list-style-type: none"> • Circuitry • Door actuator • Mode door binding or stuck • HVAC module • Door actuator arm not connected to the door crank 	<ul style="list-style-type: none"> • GO to Pinpoint Test D.
<ul style="list-style-type: none"> • Insufficient, erratic or no heat 	<ul style="list-style-type: none"> • Low engine coolant level • Engine overheating • Plugged or partially plugged heater core • Temperature blend door is binding or stuck • Temperature blend door actuator • Heater hose is kinked or binding 	<ul style="list-style-type: none"> • GO to Pinpoint Test E.
<ul style="list-style-type: none"> • The air conditioning (A/C) is inoperative 	<ul style="list-style-type: none"> • Fuse • Circuitry short/open • A/C system discharged/low charge • Dual-function pressure switch • PCM • Smart Junction Box (SJB) • HVAC module • A/C cycling switch • A/C compressor clutch air gap • A/C clutch relay 	<ul style="list-style-type: none"> • GO to Pinpoint Test F.
<ul style="list-style-type: none"> • The air conditioning (A/C) is always on — A/C compressor does not cycle 	<ul style="list-style-type: none"> • Circuitry short • PCM • <u>SJB</u> • A/C compressor clutch air gap • A/C cycling switch • A/C clutch relay 	<ul style="list-style-type: none"> • GO to Pinpoint Test G.
<ul style="list-style-type: none"> • The air conditioning (A/C) is always on — A/C mode always commanded ON 	<ul style="list-style-type: none"> • Circuitry short • PCM • <u>SJB</u> 	<ul style="list-style-type: none"> • GO to Pinpoint Test H.
<ul style="list-style-type: none"> • Temperature control is inoperative/does not operate correctly 	<ul style="list-style-type: none"> • Circuitry open/shorted • HVAC module • Temperature blend door • Temperature blend door actuator 	<ul style="list-style-type: none"> • GO to Pinpoint Test L.

<ul style="list-style-type: none"> The blower motor is inoperative 	<ul style="list-style-type: none"> Fuse(s) Circuitry open/shorted A/C blower motor switch Blower motor relay A/C blower motor 	<ul style="list-style-type: none"> GO to Pinpoint Test I.
<ul style="list-style-type: none"> The blower motor does not operate correctly 	<ul style="list-style-type: none"> Circuitry short A/C blower motor resistor A/C blower motor switch 	<ul style="list-style-type: none"> GO to Pinpoint Test J.
<ul style="list-style-type: none"> Reduced outlet airflow 	<ul style="list-style-type: none"> Circuitry short A/C compressor clutch air gap A/C cycling switch A/C clutch relay Blower motor Blower motor resistor Blower motor resistor PCM SJB 	<ul style="list-style-type: none"> If the A/C compressor does not cycle, GO to Pinpoint Test G. If the A/C compressor cycles normally, GO to Pinpoint Test J.
<ul style="list-style-type: none"> A/C pressure relief valve discharging 	<ul style="list-style-type: none"> High system pressure A/C pressure relief valve 	<ul style="list-style-type: none"> CHECK the high-side system pressure. If the pressure is below the A/C pressure relief valve open pressure, REPLACE the A/C pressure relief valve. If the system pressure is above the A/C pressure relief valve open pressure, REPAIR the system for a restriction.

Symptom Chart — NVH

Symptom Chart — NVH

Condition	Possible Causes	Action
<p>NOTE: NVH symptoms will be identified using the diagnostic tools that are available. For a list of these tools, an explanation of their uses and a glossary of common terms, refer to Section 100-04. Since it is possible any one of multiple systems may be the cause of a symptom, it may be necessary to use a process of elimination type of diagnostic approach to pinpoint the responsible system. If this is not the causal system for the symptom, refer back to Section 100-04 for the next likely system and continue diagnosis.</p>		
<ul style="list-style-type: none"> Noisy A/C compressor clutch 	<ul style="list-style-type: none"> A/C compressor clutch air gap out of specification 	<ul style="list-style-type: none"> CHECK and ADJUST the A/C compressor clutch gap if necessary. REFER to Air Conditioning (A/C) Clutch Air Gap Adjustment in this section. TEST the system for normal operation. If the A/C compressor clutch gap is OK, INSTALL an A/C compressor clutch. REFER to Section 412-01. TEST the system for normal operation.

Pinpoint Tests

Pinpoint Test A: DTC P0532 or P0533

Refer to Wiring Diagrams Cell [54](#) , Manual Climate Control System for schematic and connector information.

Normal Operation

Under normal operation, the A/C pressure transducer receives a ground from the PCM through circuit 359 (GY/RD). A 5-volt reference voltage is supplied to the A/C pressure transducer from the PCM through circuit 351 (BN/WH). The A/C pressure transducer sends a voltage to the PCM through circuit 439 (TN/RD) to indicate the A/C pressure.

- DTC P0532 A/C Pressure Refrigerant Sensor A Circuit Low — The A/C pressure transducer inputs a voltage to the PCM. If the voltage is below the calibrated level, this DTC sets.
- DTC P0533 A/C Pressure Refrigerant Sensor A Circuit High — The A/C pressure transducer inputs a voltage to the PCM. If the voltage is above the calibrated level this DTC sets.

This pinpoint test is intended to diagnose the following:

- Wiring, terminals or connectors
- A/C pressure transducer
- PCM

PINPOINT TEST A : DTC P0532 OR P0533

A1 CHECK THE PCM OUTPUT VOLTAGE

- Ignition OFF.
- Disconnect: A/C Pressure Transducer C1260 .
- Ignition ON.
- Measure the voltage between ground and A/C pressure transducer [C2160](#) Pin 2, circuit 351 (BN/WH), harness side.

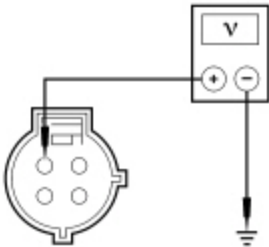

N0082573

Is the voltage between 4.7 and 5.1 volts?

Yes	GO to A2 .
No	REPAIR circuit 351 (BN/WH) for an open. CLEAR the DTCs. REPEAT the self-test. TEST the system for normal operation.

A2 CHECK THE PCM SENSOR GROUND

- Measure the voltage between A/C pressure transducer [C2160](#) Pin 1, circuit 359 (GY/RD), harness side and A/C pressure transducer [C2160](#) Pin 2, circuit 351 (BN/WH), harness side.

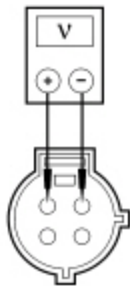

A0047632

Is the voltage between 4.7 and 5.1 volts?

Yes	If diagnosing DTC P0532, GO to A3 . If diagnosing DTC P0533, GO to A5 .
No	REPAIR circuit 359 (GY/RD) for an open. CLEAR the DTCs. REPEAT the self-test. TEST the system for normal operation.

A3 CHECK THE A/C PRESSURE TRANSDUCER HIGH

- Enter the following diagnostic mode on the scan tool: A/C Pressure (ACP_PRESS) PCM PID .
- While observing the ACP_PRESS PCM PID, connect a fused jumper between A/C pressure transducer [C2160](#) Pin 3, circuit 439 (TN/RD), harness side and A/C pressure transducer [C2160](#) Pin 2, circuit 351 (BN/WH), harness side.

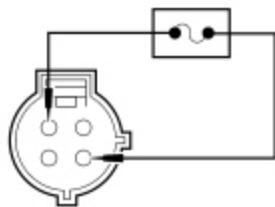

N0082574

Does the ACP_PRESS PCM PID voltage read greater than 4 volts?

Yes	INSTALL a new A/C pressure transducer. CLEAR the DTCs. REPEAT the self-test. TEST the system for normal operation.
No	GO to A4 .

A4 CHECK CIRCUIT 439 (TN/RD) FOR A SHORT TO GROUND

- Ignition OFF.
- Disconnect: PCM C175b .
- Measure the resistance between ground and A/C pressure transducer [C2160](#) Pin 3, circuit 439 (TN/RD), harness side.

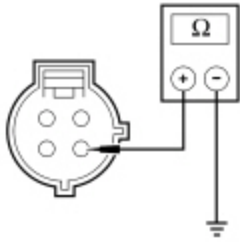

A0047688

Is the resistance greater than 10,000 ohms?

Yes	GO to A7 .
No	REPAIR circuit 439 (TN/RD) for a short to ground. CLEAR the DTCs. REPEAT the self-test. TEST the system for normal operation.

A5 CHECK THE A/C PRESSURE TRANSDUCER HIGH

- Enter the following diagnostic mode on the scan tool: A/C Pressure (ACP_PRESS) PCM PID .
- While observing the ACP_PRESS PCM PID, connect a fused jumper between A/C pressure transducer [C2160](#) Pin 3, circuit 439 (TN/RD), harness side and A/C pressure transducer [C2160](#) Pin 1, circuit 359 (GY/RD), harness side.

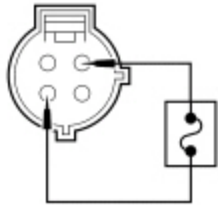

A0008126

Does the ACP_PRESS PCM PID voltage read less than 4.9 volts?

Yes	INSTALL a new A/C pressure transducer. CLEAR the DTCs. REPEAT the self-test. TEST the system for normal operation.
No	GO to A6 .

A6 CHECK CIRCUIT 439 (TN/RD) FOR A SHORT TO VOLTAGE

- Ignition OFF.
- Disconnect: PCM C175b .
- Ignition ON.
- Measure the voltage between ground and A/C pressure transducer [C2160](#) Pin 3, circuit 439 (TN/RD), harness side.

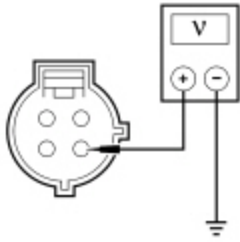

A0047689

Is any voltage present?

Yes	REPAIR circuit 439 (TN/RD) for a short to voltage. CLEAR the DTCs. REPEAT the self-test. TEST the system for normal operation.
No	GO to A7 .

A7 CHECK CIRCUIT 439 (TN/RD) FOR A SHORT TO CIRCUIT 351 (BN/WH) OR 359 (GY/RD)

- Ignition OFF.
- **NOTE:** For DTC P0532 only.

Measure the resistance between A/C pressure transducer [C2160](#) Pin 3, circuit 439 (TN/RD), harness side and A/C pressure transducer [C2160](#) Pin 1, circuit 359 (GY/RD), harness side.

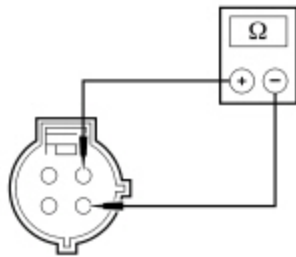

N0082575

- **NOTE:** For DTC P0533 only.

Measure the resistance between A/C pressure transducer [C2160](#) Pin 3, circuit 439 (TN/RD), harness side and A/C pressure transducer [C2160](#) Pin 2, circuit 351 (BN/WH), harness side.

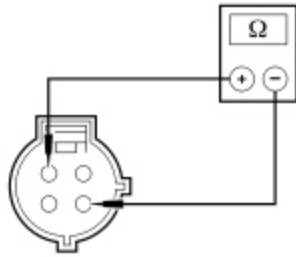

N0082576

Is the resistance greater than 10,000 ohms?

Yes	GO to A8 .
No	REPAIR circuit 439 (TN/RD) for a short to circuit 351 (BN/WH) or 359 (GY/RD). CLEAR the DTCs. REPEAT the self-test. TEST the system for normal operation.

A8 CHECK CIRCUIT 439 (TN/RD) FOR AN OPEN

- Measure the resistance between A/C pressure transducer [C2160](#) Pin 3, circuit 439 (TN/RD), harness side and PCM [C175B](#) Pin 26, circuit 439 (TN/RD), harness side.

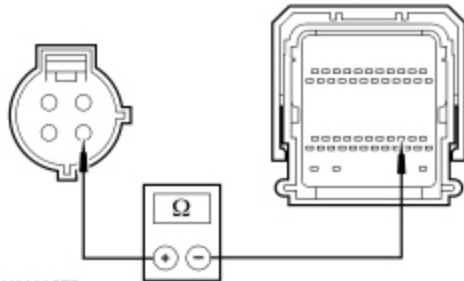

N0082577

Is the resistance less than 5 ohms?

Yes	GO to A9 .
No	REPAIR circuit 439 (TN/RD) for an open. CLEAR the DTCs. REPEAT the self-test. TEST the system for normal operation.

A9 CHECK THE PCM MODULE CONNECTION

- Clear the DTCs.
- Disconnect all the PCM connectors.
- Check for:
 - corrosion.
 - pushed-out pins.
 - incorrectly seated connector.

- Connect and correctly seat all the PCM connectors.
- Operate the system.

Does the concern return?

Yes	INSTALL a new PCM. TEST the system for normal operation.
No	The system is operating correctly at this time. The concern may have been caused by a loose or corroded connector.

Pinpoint Test B: DTC P0645 — Air Conditioning Clutch Relay (A/CCR) Control Circuit

Refer to Wiring Diagrams Cell [54](#) , Manual Climate Control System for schematic and connector information.

Normal Operation

Under normal operation, voltage is provided to the A/C clutch relay coil from Bussed Electrical Center (BEC) fuse 47 (15A). When A/C is requested, and A/C line pressures allow, a ground is provided to the A/C clutch relay from the PCM through circuit 321 (GY/WH), energizing the A/C clutch relay.

- DTC P0645 — A/C Clutch Relay Control Circuit — The DTC sets when the PCM grounds the relay circuit and excessive current draw is detected on the relay circuit. The DTC also sets when the relay circuit is OFF and no voltage is detected on the relay circuit. The PCM expects to detect voltage coming through the relay coil to the relay circuit when it is not grounding it.

This pinpoint test is intended to diagnose the following:

- Wiring, terminals or connectors
- A/C clutch relay
- PCM

PINPOINT TEST B : DTC P0645 — AIR CONDITIONING CLUTCH RELAY (A/CCR) CONTROL CIRCUIT

B1 CHECK THE VOLTAGE TO THE A/C CLUTCH RELAY

NOTICE: Use the Flex Probe Kit for all test connections to prevent damage to the wiring terminals. Do not use the test probe.

- Ignition OFF.
- Disconnect: A/C Clutch Relay .
- Ignition ON.
- Measure the voltage between ground and the A/C clutch relay socket.

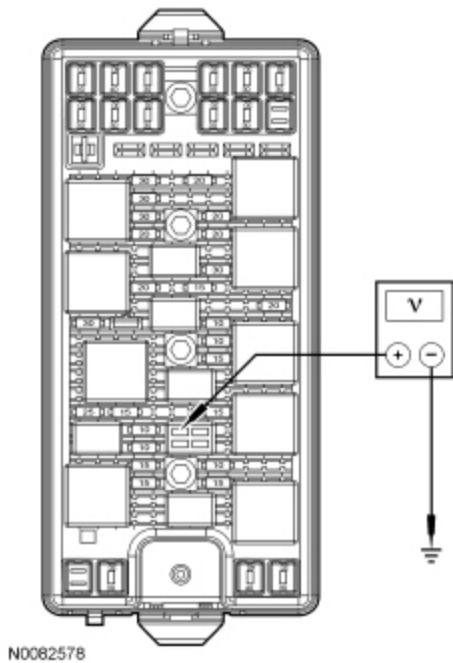

Is the voltage greater than 10 volts?

Yes	CARRY OUT the A/C clutch relay component test. REFER to Refer to Wiring Diagrams Cell 149 for component testing. If the relay tests OK, GO to B2 .
No	VERIFY BEC fuse 47 (15A) is OK. If OK, INSTALL a new BEC . If not OK, refer to the Wiring Diagrams Manual to identify the possible causes of the circuit short. CLEAR the DTCs. REPEAT the self-test. TEST the system for normal operation.

B2 CHECK CIRCUIT 321 (GY/WH) FOR A SHORT TO VOLTAGE

- Ignition OFF.
- Disconnect: PCM C175b .
- Ignition ON.
- Measure the voltage between ground and PCM [C175B](#) Pin 14, circuit 321 (GY/WH), harness side.

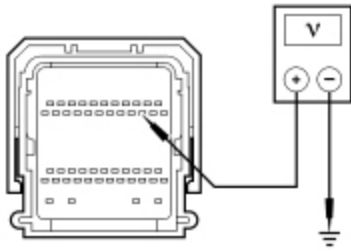

N0082579

Is any voltage present?

Yes	REPAIR circuit 321 (GY/WH) for a short to voltage. CLEAR the DTCs. REPEAT the self-test. TEST the system for normal operation.
No	GO to B3 .

B3 CHECK CIRCUIT 321 (GY/WH) FOR A SHORT TO GROUND

- Ignition OFF.
- Measure the resistance between ground and PCM [C175B](#) Pin 14, circuit 321 (GY/WH), harness side.

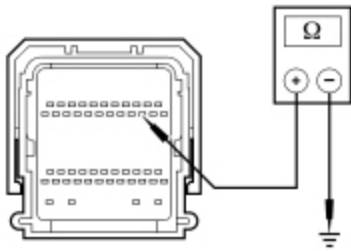

N0082580

Is the resistance greater than 10,000 ohms?

Yes	GO to B4 .
No	REPAIR circuit 321 (GY/WH) for a short to ground. CLEAR the DTCs. REPEAT the self-test. TEST the system for normal operation.

B4 CHECK CIRCUIT 321 (GY/WH) FOR AN OPEN

NOTICE: Use the Flex Probe Kit for all test connections to prevent damage to the wiring terminals. Do not use the test probe.

- Measure the resistance between A/C clutch relay socket, circuit 321 (GY/WH) and PCM [C175B](#) Pin 14, circuit 321 (GY/WH), harness side.

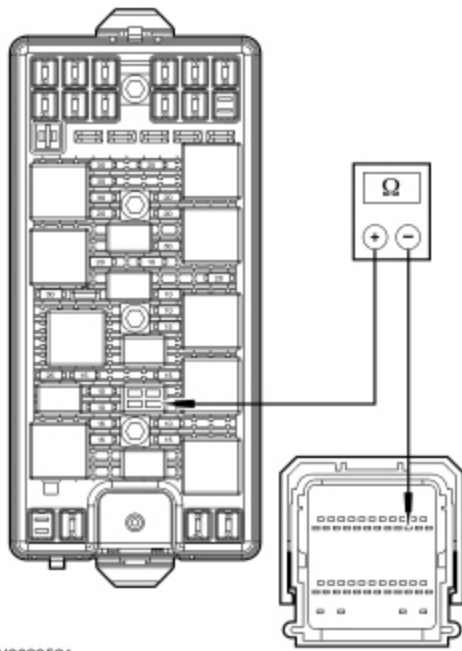

N0082581

Is the resistance less than 5 ohms?

Yes	GO to B5 .
No	REPAIR circuit 321 (GY/WH) for an open. CLEAR the DTCs. REPEAT the self-test. TEST the system for normal operation.

B5 CHECK THE PCM MODULE CONNECTION

- Clear the DTCs.
- Disconnect all the PCM connectors.
- Check for:
 - corrosion.
 - pushed-out pins.
 - incorrectly seated connector.
- Connect and correctly seat all the PCM connectors.
- Operate the system.

Does the concern return?

Yes	INSTALL a new PCM. TEST the system for normal operation.
No	The system is operating correctly at this time. The concern may have been caused by a loose or corroded connector.

Pinpoint Test C: The Air Inlet Mode Door is Inoperative

Refer to Wiring Diagrams Cell [54](#) , Manual Climate Control System for schematic and connector information.

Normal Operation

Under normal operation, the air inlet mode door actuator motor is supplied voltage or ground on circuit 1116 (DG), depending on desired actuator rotation, by the HVAC module. The HVAC module then supplies the appropriate voltage or ground to the other side of the actuator motor on circuit 1117 (LG).

This pinpoint test is intended to diagnose the following:

- Wiring, terminals or connectors
- Air inlet mode door actuator
- HVAC module
- Stuck or bound linkage or door

PINPOINT TEST C : THE AIR INLET MODE DOOR IS INOPERATIVE

C1 CHECK THE AIR INLET MODE DOOR ACTUATOR CLOCKWISE OPERATION

- Disconnect: HVAC Module C294a .
- Remove the door actuator and disengage the actuator driveshaft from the actuator door.
- Mark the door actuator driveshaft position.
- Connect a fused jumper wire between:
 - HVAC module [C294A](#) Pin 8, circuit 1116 (DG), harness side and [C294A](#) Pin 1, circuit 1205 (BK), harness side.
 - HVAC module [C294A](#) Pin 9, circuit 1117 (LG), harness side and [C294A](#) Pin 26, circuit 1566 (RD/YE), harness side.

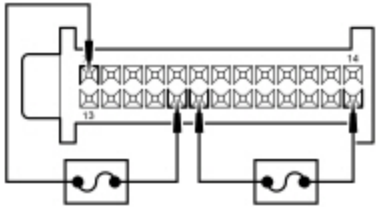

A0072894

Does the actuator motor move in the clockwise direction?

Yes	GO to C2 .
No	GO to C3 .

C2 CHECK THE AIR INLET MODE DOOR ACTUATOR COUNTERCLOCKWISE OPERATION

- Connect a fused jumper wire between:
 - HVAC module [C294A](#) Pin 8, circuit 1116 (DG), harness side and [C294A](#) Pin 26, circuit 1566 (RD/YE), harness side.
 - HVAC module [C294A](#) Pin 9, circuit 1117 (LG), harness side and [C294A](#) Pin 1, circuit 1205 (BK), harness side.

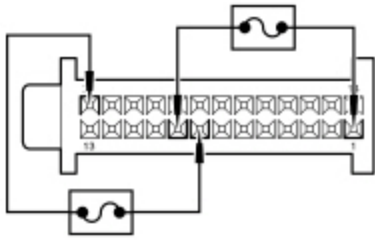

A0072895

Does the actuator motor move in the counterclockwise direction?

Yes	INSPECT for binding or broken door and linkage. If no condition is found, GO to C9 .
No	GO to C3 .

C3 CHECK CIRCUIT 1116 (DG) FOR A SHORT TO GROUND

- Disconnect: Air Inlet Mode Door Actuator C2325 .
- Measure the resistance between ground and HVAC module [C294A](#) Pin 8, circuit 1116 (DG), harness side.

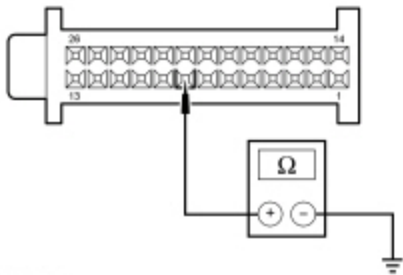

A0072896

Is the resistance greater than 10,000 ohms?

Yes	GO to C4 .
No	REPAIR circuit 1116 (DG) for a short to ground. TEST the system for normal operation.

C4 CHECK CIRCUIT 1117 (LG) FOR A SHORT TO GROUND

- Measure the resistance between ground and HVAC module [C294A](#) Pin 9, circuit 1117 (LG), harness side.

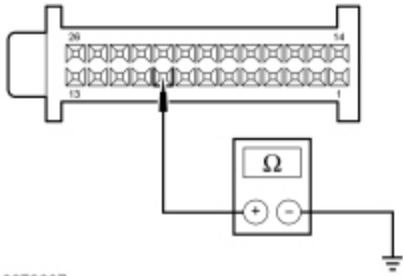

A0072897

Is the resistance greater than 10,000 ohms?

Yes	GO to C5 .
No	REPAIR circuit 1117 (LG) for a short to ground. TEST the system for normal operation.

C5 CHECK CIRCUIT 1116 (DG) FOR A SHORT TO VOLTAGE

- Ignition ON.
- Measure the voltage between ground and HVAC module [C294A](#) Pin 8, circuit 1116 (DG), harness side.

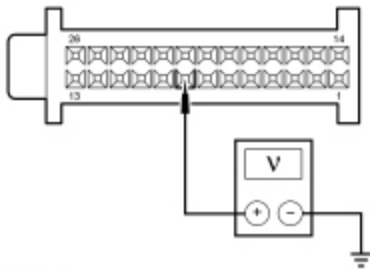

A0072898

Is any voltage present?

Yes	REPAIR circuit 1116 (DG) for a short to voltage. TEST the system for normal operation.
No	GO to C6 .

C6 CHECK CIRCUIT 1117 (LG) FOR A SHORT TO VOLTAGE

- Measure the voltage between ground and HVAC module [C294A](#) Pin 9, circuit 1117 (LG), harness side.

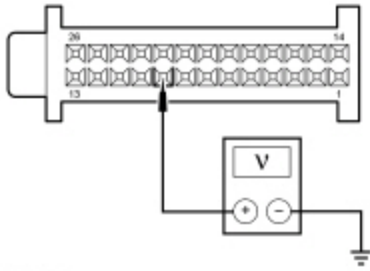

A0072899

Is any voltage present?

Yes	REPAIR circuit 1117 (LG) for a short to voltage. TEST the system for normal operation.
No	GO to C7 .

C7 CHECK CIRCUIT 1116 (DG) FOR AN OPEN

- Ignition OFF.
- Measure the resistance between HVAC module [C294A](#) Pin 8, circuit 1116 (DG), harness side and air inlet mode door actuator [C2325](#) Pin 1, circuit 1116 (DG), harness side.

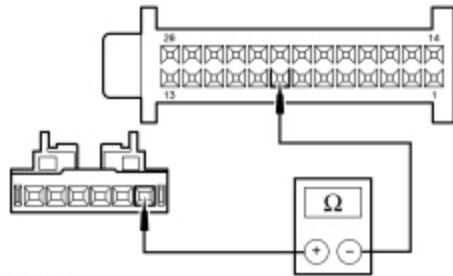

A0072900

Is the resistance less than 5 ohms?

Yes	GO to C8 .
No	REPAIR circuit 1116 (DG) for an open. TEST the system for normal operation.

C8 CHECK CIRCUIT 1117 (LG) FOR AN OPEN

- Measure the resistance between HVAC module [C294A](#) Pin 9, circuit 1117 (LG), harness side and air inlet mode door actuator [C2325](#) Pin 6, circuit 1117 (LG), harness side.

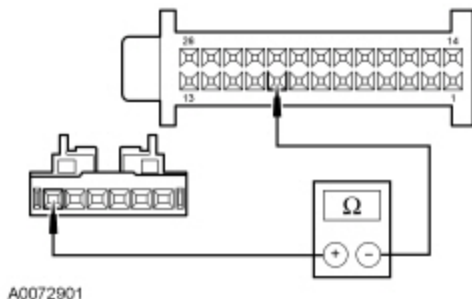

Is the resistance less than 5 ohms?

Yes	INSPECT for binding or broken linkage. If no condition is found, INSTALL a new air inlet mode door actuator. TEST the system for normal operation.
No	REPAIR circuit 1117 (LG) for an open. TEST the system for normal operation.

C9 CHECK THE MODULE CONNECTION

- Carry out the HVAC Module Cold Boot Process.
- Operate the system.

Does the concern return?

Yes	INSTALL a new HVAC module. REFER to Section 412-01 . TEST the system for normal operation.
No	The system is operating correctly at this time. The concern may have been caused by a loose or corroded connector. TEST the system for normal operation.

Pinpoint Test D: Incorrect/Erratic Direction of Airflow From Outlet(s)

Refer to Wiring Diagrams Cell [54](#) , Manual Climate Control System for schematic and connector information.

Normal Operation

Under normal operation, to rotate the mode door actuator clockwise, the HVAC module supplies voltage to the DEFROST and FLOOR/PANEL mode door actuator motors through the door actuator feed B circuits, and supplies ground through the door actuator feed A circuits. To rotate the mode door actuator counterclockwise, the HVAC module reverses the voltage and ground circuits.

The mode door actuator feedback resistors are supplied a ground from the HVAC module by the mode door actuator return circuits and a 5-volt reference voltage on the mode door actuator reference circuits. The HVAC module reads the voltage on the mode door actuator feedback circuits to determine the mode door actuator position by the position of the actuator feedback resistor wiper arm.

Door actuator feed B circuits

- Defrost — 1137 (YE/LG)
- Floor/Panel — 1129 (BN/WH)

Door actuator feed A circuits

- Defrost — 1136 (RD/WH)
- Floor/Panel — 1128 (GY/LB)

Door actuator return circuits

- Defrost — 438 (RD/WH)
- Floor/Panel — 438 (RD/WH)

Door actuator reference circuits

- Defrost — 436 (RD/LG)
- Floor/Panel — 436 (RD/LG)

Door actuator feedback circuits

- Defrost — 1982 (LB/BK)
- Floor/Panel — 435 (YE/LB)

This pinpoint test is intended to diagnose the following:

- Wiring, terminals or connectors
- HVAC module
- Stuck or bound linkage or door

PINPOINT TEST D : INCORRECT/ERRATIC DIRECTION OF AIRFLOW FROM OUTLET(S)

D1 CHECK THE AIRFLOW

- Ignition ON.
- Check the airflow in the PANEL, DEFROST and FLOOR modes.

Is the airflow correct in each setting?

Yes	The system is operating normally.
No	If the RECIRC button does not change the air inlet door position, GO to Pinpoint Test C. GO to D2 .

D2 CHECK THE FEEDBACK POTENTIOMETER TOTAL RESISTANCE

NOTICE: Use the correct size flex probe from the Flex Probe Kit for all test connections. The use of the correct size flex probe is critical to avoid damage to the connector terminals.

NOTE: Check all electrical connectors for proper seating before disconnecting. If incorrectly seated, reseal and lock the connector. Test the system operation. If the condition remains, continue with this test.

- Disconnect: HVAC Module C294a .
- Measure the resistance between HVAC module [C294A](#) Pin 5, circuit 436 (RD/LG) and HVAC module [C294A](#) Pin 15, circuit 438 (RD/WH).

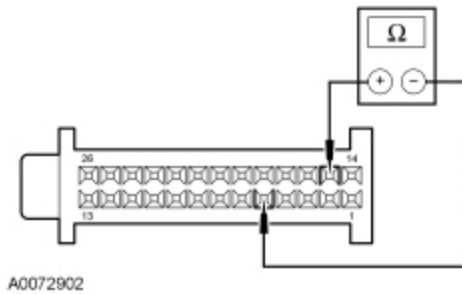

Is the resistance greater than 500 ohms?

Yes	If the airflow is from the floor only or panel only in any mode except OFF and DEFROST and airflow is from defrost only on DEFROST mode, follow diagnostics for floor/panel mode door actuator. GO to D3 . If the airflow is from the defrost only in all modes except OFF or from FLOOR/PANEL in DEFROST mode, follow diagnostics for defrost mode door actuator. GO to D3 .
No	REPAIR circuits 436 (RD/LG) and 438 (RD/WH) for a short together. TEST the system for normal operation.

D3 CHECK THE POTENTIOMETER LOW- AND HIGH-SIDE RESISTANCE

- Measure the **low-side** resistance between HVAC module [C294A](#) Pin 15, circuit 438 (RD/WH) and the following:
 - **For floor/panel mode door actuator:** HVAC module [C294A](#) Pin 16, circuit 435 (YE/LB).
 - **For defrost mode door actuator:** HVAC module [C294A](#) Pin 17, circuit 1982 (LB/BK).

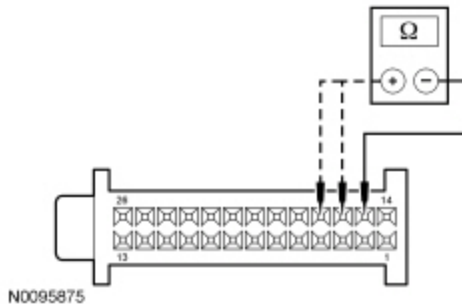

- Measure the **high-side** resistance between HVAC module [C294A](#) Pin 5, circuit 436 (RD/LG) and the following:
 - **For floor/panel mode door actuator:** HVAC module [C294A](#) Pin 16, circuit 435 (YE/LB).
 - **For defrost mode door actuator:** HVAC module [C294A](#) Pin 17, circuit 1982 (LB/BK).

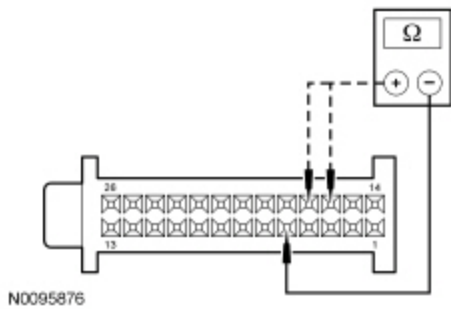

N0095876

Is the resistance between 225 and 11,275 ohms?

Yes	GO to D4 .
No	<p>CARRY OUT the Floor/Panel Mode Door Actuator or Defrost Mode Door Actuator Component Test in this section. If the actuator tests OK and:</p> <p>If the low-side resistance only is greater than 11,275 ohms, REPAIR circuit 438 (RD/WH) for an open. CLEAR the DTCs. REPEAT the self-test. TEST the system for normal operation.</p> <p>If the low-side resistance only is less than 225 ohms, REPAIR circuits (floor/panel) 435 (YE/LB) or (defrost) 1982 (LB/BK) and 438 (RD/WH) for a short together. CLEAR the DTCs. REPEAT the self-test. TEST the system for normal operation.</p> <p>If the high-side resistance only is greater than 11,275 ohms, REPAIR circuit 436 (RD/LG) for an open. CLEAR the DTCs. REPEAT the self-test. TEST the system for normal operation.</p> <p>If the high-side resistance only is less than 225 ohms, REPAIR circuits (floor/panel) 435 (YE/LB) or (defrost) 1982 (LB/BK) and 436 (RD/LG) for a short together. CLEAR the DTCs. REPEAT the self-test. TEST the system for normal operation.</p> <p>If the high-side and low-side resistance is greater than 11,275 ohms, REPAIR circuit (floor/panel) 435 (YE/LB) or (defrost) 1982 (LB/BK) for an open. CLEAR the DTCs. REPEAT the self-test. TEST the system for normal operation.</p>

D4 CHECK CIRCUITS 436 (RD/LG), 435 (YE/LB) OR 1982 (LB/BK) FOR A SHORT TO GROUND

- Measure the resistance between ground and the following:
 - HVAC module [C294A](#) Pin 5, circuit 436 (RD/LG).
 - **For floor/panel door actuator:** HVAC module [C294A](#) Pin 16, circuit 435 (YE/LB).
 - **For defrost door actuator:** HVAC module [C294A](#) Pin 17, circuit 1982 (LB/BK).

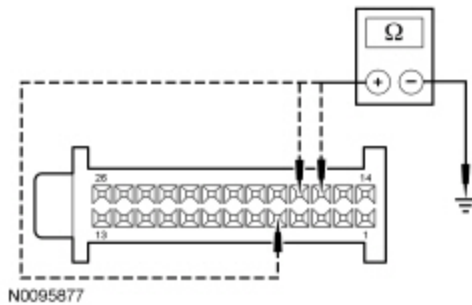

N0095877

Is the resistance greater than 10,000 ohms?

Yes	GO to D5 .
No	REPAIR circuit(s) for a short to ground. TEST the system for normal operation.

D5 CHECK CIRCUITS 438 (RD/WH), 435 (YE/LB) OR 1982 (LB/BK) FOR A SHORT TO POWER

- Ignition ON.
- Measure the voltage between ground and the following:
 - HVAC module [C294A](#) Pin 15, circuit 438 (RD/WH).
 - **For floor/panel door actuator:** HVAC module [C294A](#) Pin 16, circuit 435 (YE/LB).
 - **For defrost door actuator:** HVAC module [C294A](#) Pin 17, circuit 1982 (LB/BK).

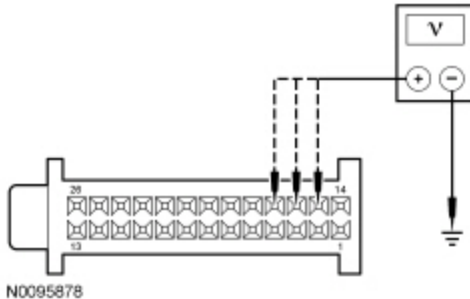

Is any voltage present?

Yes	REPAIR circuit(s) for a short to power. TEST the system for normal operation.
No	For floor/panel mode door actuator: GO to D6 . For defrost mode door actuator: GO to D7 .

D6 CHECK THE FLOOR/PANEL MODE DOOR ACTUATOR OPERATION

NOTE: If a jumper fuse opens while carrying out this test step, repair the circuit(s) for a short.

- Measure the **low-side** resistance between HVAC module [C294A](#) Pin 15, circuit 438 (RD/WH) and HVAC module [C294A](#) Pin 16, circuit 435 (YE/LB).

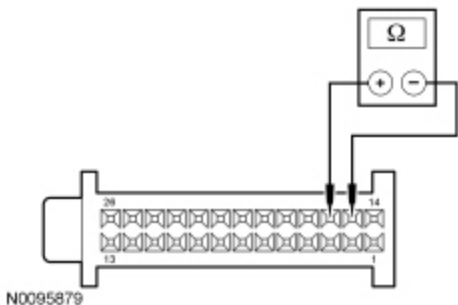

- For no more than 3 seconds, connect a fused jumper wire between:
 - HVAC module [C294A](#) Pin 26, circuit 1566 (RD/YE) and HVAC module [C294A](#) Pin 20, circuit 1129 (BN/WH).

- HVAC module [C294A](#) Pin 1, circuit 1205 (BK) and HVAC module [C294A](#) Pin 19, circuit 1128 (GY/LB).

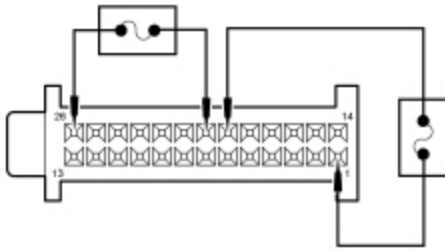

N0095880

- Remove the fused jumpers.
- For no more than 3 seconds, connect a fused jumper wire between:
 - HVAC module [C294A](#) Pin 1, circuit 1205 (BK) and HVAC module [C294A](#) Pin 20, circuit 1129 (BN/WH).
 - HVAC module [C294A](#) Pin 26, circuit 1566 (RD/YE) and HVAC module [C294A](#) Pin 19, circuit 1128 (GY/LB).

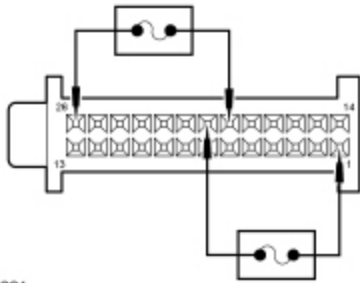

N0095881

Does the resistance smoothly increase and/or decrease when the jumpers are connected?

Yes	INSPECT for broken door and linkage. REPAIR as necessary. If no condition is found, GO to D9 .
No	GO to D8 .

D7 CHECK THE DEFROST MODE DOOR ACTUATOR OPERATION

- Measure the **low-side** resistance between HVAC module [C294A](#) Pin 15, circuit 438 (RD/WH) and HVAC module [C294A](#) Pin 17, circuit 1982 (LB/BK).

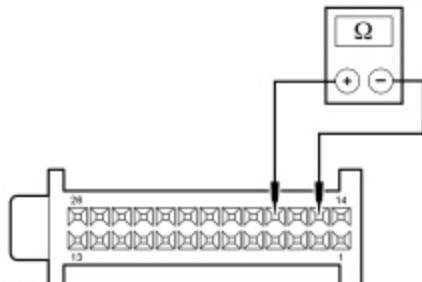

N0095882

- For no more than 3 seconds, connect a fused jumper wire between:
 - HVAC module [C294A](#) Pin 26, circuit 1566 (RD/YE) and HVAC module [C294A](#) Pin 25, circuit 1137 (YE/LG).
 - HVAC module [C294A](#) Pin 1, circuit 1205 (BK) and HVAC module [C294A](#) Pin 24, circuit 1136 (RD/WH).

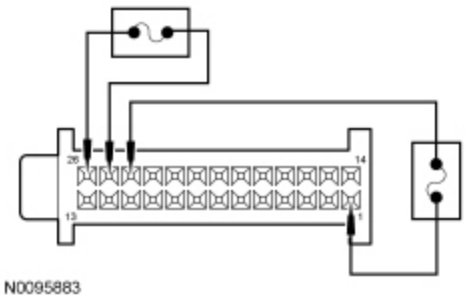

- For no more than 3 seconds, connect a fused jumper wire between:
 - HVAC module [C294A](#) Pin 1, circuit 1205 (BK) and HVAC module [C294A](#) Pin 25, circuit 1137 (YE/LG).
 - HVAC module [C294A](#) Pin 26, circuit 1566 (RD/YE) and HVAC module [C294A](#) Pin 24, circuit 1136 (RD/WH).

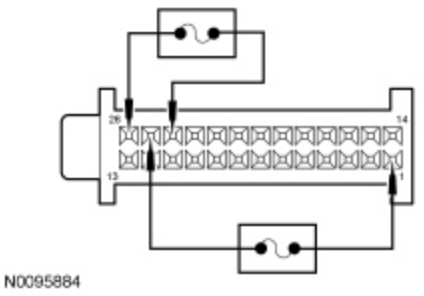

Does the resistance smoothly increase and/or decrease when the jumpers are connected?

Yes	INSPECT for broken door and linkage. REPAIR as necessary. If no condition is found, GO to D9 .
No	GO to D8 .

D8 CHECK THE ACTUATOR MOTOR DRIVE CIRCUITS FOR AN OPEN

NOTE: Due to limited connector accessibility, before carrying out this test step, visually inspect the wiring between the HVAC module and actuator for opens or shorts. If no damage is visually evident, proceed with the test.

- Ignition OFF.
- Disconnect: Floor/Panel Door Actuator C234 or Defrost Door Actuator C232 .
- Measure the resistance between:
 - **For floor/panel door actuator:** HVAC module [C294A](#) Pin 20, circuit 1129 (BN/WH) and floor/panel door actuator [C234](#) Pin 6, circuit 1129 (BN/WH).
 - **For defrost door actuator:** HVAC module [C294A](#) Pin 25, circuit 1137 (YE/LG) and defrost door actuator [C232](#) Pin 6, circuit 1997 (BN/YE).

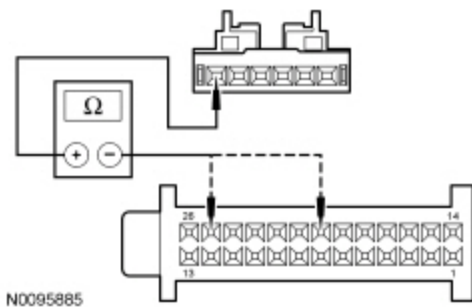

• Measure the resistance between:

- **For floor/panel door actuator:** HVAC module [C294A](#) Pin 19, circuit 1128 (GY/LB) and floor/panel door actuator [C234](#) Pin 1, circuit 1128 (GY/LB).
- **For defrost door actuator:** HVAC module [C294A](#) Pin 24, circuit 1136 (RD/WH) and defrost door actuator [C232](#) Pin 1, circuit 1136 (RD/WH).

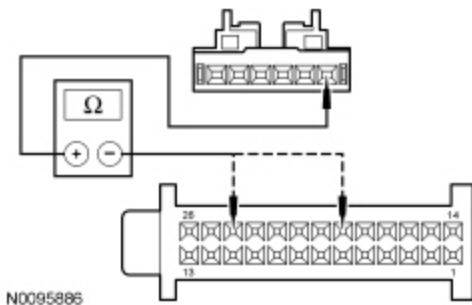

Are the resistances less than 5 ohms?

Yes	INSPECT for binding or broken linkage. REPAIR as necessary. If no condition is found, INSTALL a new door actuator. TEST the system for normal operation.
No	REPAIR the circuit(s) for an open. TEST the system for normal operation.

D9 MODULE ACTUATOR POSITION CALIBRATION

NOTE: The purpose of the module actuator position calibration is to allow the HVAC module to reinitialize and calibrate the actuator stop points. To carry out the calibration, follow the steps below.

- Ignition OFF.
 - Inspect the module connectors for:
 - corrosion.
 - pushed-out terminals.
 - damaged terminals.
 - Connect: EMTC Module C294a .
 - Ignition ON.
 - Select any position except OFF.
 - **NOTE:** The HVAC module will now initialize and calibrate the actuators. Calibration of the actuators will take approximately 30 seconds.
- Operate the system.

Does the concern return?

Yes	INSTALL a new HVAC module. REFER to Section 412-01 . TEST the system for normal operation.
No	The system is now operating correctly. The concern may have been caused by a foreign object in the HVAC case or temporary binding that restricted actuator door travel. CHECK any actuator external linkage. If condition recurs, INSPECT actuator linkage and door for binding and CHECK HVAC case for foreign objects.

Pinpoint Test E: Insufficient, Erratic or No Heat

Normal Operation

Under normal operation, warm coolant flows from the engine through the heater core and back to the engine.

This pinpoint test is intended to diagnose the following:

- Plugged heater core
- Coolant level
- Temperature blend door

PINPOINT TEST E : INSUFFICIENT, ERRATIC OR NO HEAT

E1 CHECK FOR CORRECT ENGINE COOLANT LEVEL

- Ignition OFF.
- Check the engine coolant level when hot and cold.

Is the engine coolant at the correct level (hot/cold) as indicated on the engine coolant recovery reservoir?

Yes	GO to E3 .
No	GO to E2 .

E2 CHECK THE ENGINE COOLING SYSTEM FOR LEAKS

- Pressure test the cooling system for leaks. Refer to [Section 303-03A](#).

Does the engine cooling system leak?

Yes	REPAIR the engine coolant leak. TEST the system for normal operation.
No	GO to E3 .

E3 CHECK FOR COOLANT FLOW TO THE HEATER CORE

- Ignition ON.

- Run the engine until it reaches normal operating temperature. Select the FLOOR position on the control assembly. Set the temperature control to full warm.
- Using a suitable temperature measuring device, check the heater core inlet hose to see if it is hot.

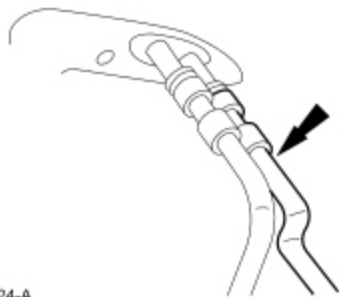

GL1024-A

Is the heater core inlet hose hot?

Yes	GO to E4 .
No	REFER to Section 303-03A to check cooling system function.

E4 CHECK FOR A PLUGGED OR RESTRICTED HEATER CORE

- Using a suitable temperature measuring device, measure the heater core outlet hose temperature.

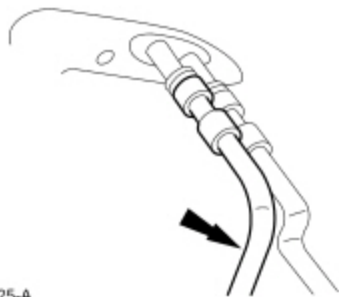

GL1025-A

Is the heater core outlet hose temperature similar to the inlet hose temperature (within approximately 6-17°C [10-30°F])?

Yes	GO to Pinpoint Test D and diagnose for a blend door actuator.
No	INSTALL a new heater core. TEST the system for normal operation.

Pinpoint Test F: The Air Conditioning (A/C) Is Inoperative

Refer to Wiring Diagrams Cell [54](#) , Manual Climate Control System for schematic and connector information.

Normal Operation

Under normal operation, when A/C is requested, a ground signal is sent from the HVAC module to the Smart Junction Box (SJB) through circuit 1397 (GY/RD). The SJB then transmits an A/C request message through the High Speed Controller Area Network (HS-CAN) bus to the PCM.

4.0L only

Voltage is provided to the A/C cycling switch through circuit 391 (RD/YE). If the A/C cycling switch is closed (sufficient pressure) voltage is sent from the A/C cycling switch to the PCM (4.0L) through circuit 198 (DG/OG)/420 (DB/YE). When the PCM receives voltage from the pressure switch and the A/C pressure transducer does not indicate excessive pressure, the PCM provides a ground for the A/C clutch relay through circuit 321 (GY/WH).

4.6L and 5.4L only

Voltage is provided to the A/C cycling switch through circuit 391 (RD/YE). If the A/C cycling switch is closed (sufficient pressure) voltage is sent from the A/C cycling switch to the dual-function pressure switch (4.6L and 5.4L) through circuit 198 (DG/OG). If the dual-function pressure switch (4.6L and 5.4L) is closed (pressure not excessive), voltage is sent to the PCM through circuit 420 (DB/YE). When the PCM receives voltage from the pressure switches, the PCM provides a ground for the A/C clutch relay through circuit 321 (GY/WH).

When the relay is activated, ignition voltage is supplied to the A/C clutch solenoid through circuit 883 (PK/LB). Ground is supplied for the A/C clutch through circuit 1205 (BK).

This pinpoint test is intended to diagnose the following:

- Fuse
- Wiring, terminals or connectors
- PCM
- HVAC module
- A/C cycling switch
- Dual-function pressure switch
- A/C compressor clutch field coil
- A/C control relay
- A/C clutch air gap

PINPOINT TEST F : THE AIR CONDITIONING (A/C) IS INOPERATIVE

NOTICE: It is important to install relays in their correct position in the Bussed Electrical Center (BEC) . Installing a relay incorrectly may cause wiring shorts or damage to modules. While carrying out diagnostics on BEC relays, have only one BEC relay removed at a time. Failure to follow these instructions may result in damage to the vehicle circuitry or to control modules.

NOTE: Some PCM DTCs may inhibit A/C operation. If any PCM DTCs are retrieved, diagnose those first. Refer to the PCM DTC Chart.

NOTE: Before carrying out the following test, check that the A/C system pressure is above 290 kPa (42 psi). If the pressure is below 290 kPa (42 psi), refer to [Fluorescent Dye Leak Detection](#) in this section.

F1 CHECK THE AIR CONDITIONING REQUEST SIGNAL (AC_REQST) GEM PID

- Ignition ON.
- Enter the following diagnostic mode on the scan tool: AC_REQST GEM PID .
- With the engine running, select PANEL mode and press the A/C button on the HVAC module.

Does the AC_REQST GEM PID read ON?

Yes	GO to F5 .
No	GO to F2 .

F2 CHECK THE A/C SIGNAL WITH THE A/C ON

- Ignition OFF.
- Disconnect: [SJB C2280b](#) .
- Disconnect: [SJB C2280a](#) .
- Ignition ON.
- Select PANEL mode and press the A/C button on the HVAC module.
- Measure the voltage between [SJB C2280B](#) Pin 29, circuit 1397 (GY/RD), harness side and [SJB C2280A](#) Pin 36, circuit 1044 (WH/YE), harness side.

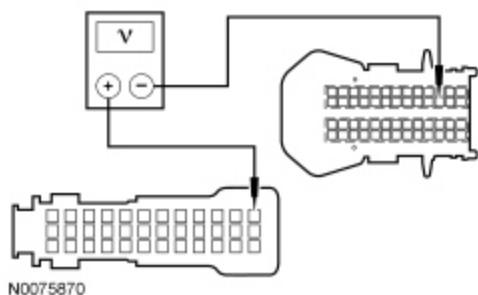

Is the voltage greater than 10 volts?

Yes	GO to F18 .
No	GO to F3 .

F3 CHECK CIRCUIT 1397 (GY/RD) FOR A SHORT TO VOLTAGE

- Ignition OFF.
- Disconnect: HVAC Module [C294a](#) .
- Ignition ON.
- Measure the voltage between HVAC module [C294A](#) Pin 3, circuit 1397 (GY/RD), harness side and ground.

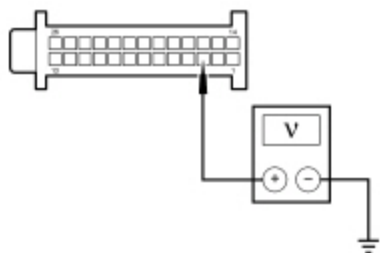

Is any voltage present?

Yes	REPAIR circuit 1397 (GY/RD) for a short to voltage. TEST the system for normal operation.
No	GO to F4 .

F4 CHECK CIRCUIT 1397 (GY/RD) FOR AN OPEN

- Ignition OFF.
- Disconnect: HVAC Module C294a .
- Measure the resistance between HVAC module [C294A](#) Pin 3, circuit 1397 (GY/RD), harness side and [SJB C2280B](#) Pin 29, circuit 1397 (GY/RD), harness side.

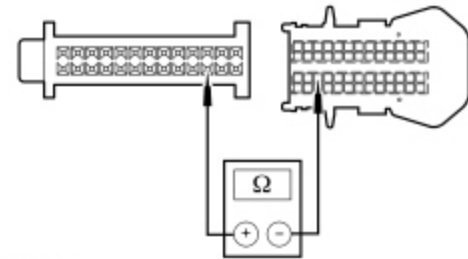

A0081824

Is the resistance less than 5 ohms?

Yes	GO to F19 .
No	REPAIR circuit 1397 (GY/RD) for an open. TEST the system for normal operation.

F5 CHECK THE AIR CONDITIONING COMPRESSOR CYCLING SWITCH (ACCS) PCM PID WITH THE A/C ON

- Enter the following diagnostic mode on the scan tool: ACCS PCM PID .
- Select PANEL mode and press the A/C button on the HVAC module.

Does the ACCS PCM PID read ON?

Yes	For 4.0L, GO to F6 . For 4.6L and 5.4L, GO to F12 .
No	GO to F7 .

F6 CHECK THE A/C PRESSURE SENSOR (ACP_PRESS) PCM PID

- Enter the following diagnostic mode on the scan tool: A/C Pressure PCM PID .
- With the manifold gauge set connected, compare the pressure readings of the manifold gauge set and the ACP_PRESS PCM PID.

Are the pressure values of the manifold gauge set and the ACP_PRESS PCM PID similar?

Yes	GO to F12 .
------------	-----------------------------

No | INSTALL a new A/C pressure transducer. TEST the system for normal operation.

F7 CHECK THE ACCS PCM INPUT

- Ignition OFF.
- Disconnect: PCM C175b .
- Ignition ON.
- Measure the voltage between PCM [C175B](#) Pin 15, circuit 420 (DB/YE), harness side and ground.

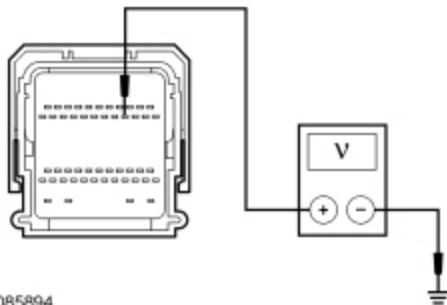

Is the voltage greater than 10 volts?

Yes	GO to F20 .
No	GO to F8 .

F8 CHECK THE A/C CYCLING SWITCH VOLTAGE

- Ignition OFF.
- Disconnect: A/C Cycling Switch C130 .
- Ignition ON.
- Measure the voltage between ground and A/C cycling switch [C130](#) Pin 1, circuit 298 (VT/OG), harness side.

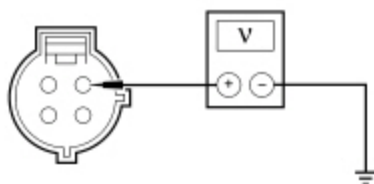

Is the voltage greater than 10 volts?

Yes	GO to F9 .
No	VERIFY SJB fuse 14 (5A) is OK. If OK, REPAIR circuit 298 (VT/OG) for an open. If not OK, REFER to the Wiring Diagrams Manual to identify the possible causes of the circuit short. TEST the system for normal operation.

F9 CHECK CIRCUIT 420 (DB/YE)/198 (DG/OG) FOR AN OPEN

- Ignition OFF.
- Disconnect: PCM C175b (4.0L only) .
- Disconnect: Dual-Function Pressure Switch C1078 (4.6L and 5.4L only) .
- **NOTE:** 4.0L only.

Measure the resistance between A/C cycling switch [C130](#) Pin 4, circuit 198 (DG/OG), harness side and PCM [C175B](#) Pin 15, circuit 420 (DB/YE), harness side.

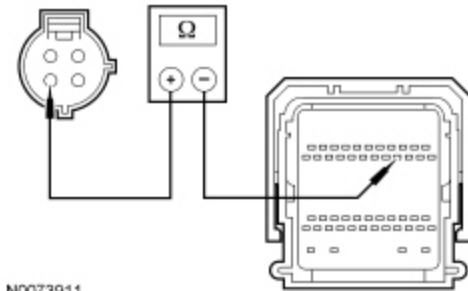

N0073911

- **NOTE:** 4.6L and 5.4L only.

Measure the resistance between A/C cycling switch [C130](#) Pin 4, circuit 198 (DG/OG), harness side and dual-function pressure switch [C1078](#) Pin 1, circuit 198 (DG/OG), harness side.

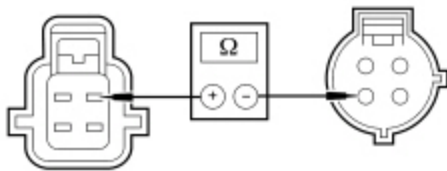

N0008285

Is the resistance less than 5 ohms?

Yes	For 4.0L, INSTALL a new A/C cycling switch. TEST the system for normal operation. For 4.6L and 5.4L, GO to F10 .
No	REPAIR circuit 420 (DB/YE)/198 (DG/OG) for an open. TEST the system for normal operation.

F10 CHECK VOLTAGE TO THE DUAL-FUNCTION PRESSURE SWITCH

- Ignition OFF.
- Connect: A/C Cycling Switch C130 .
- Ignition ON.
- Measure the voltage between dual-function pressure switch [C1078](#) Pin 1, circuit 198 (DG/OG), harness side and ground.

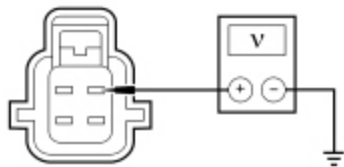

A0042077

Is the voltage greater than 10 volts?

Yes	GO to F11 .
No	INSTALL a new A/C cycling switch. TEST the system for normal operation.

F11 CHECK CIRCUIT 420 (DB/YE) FOR AN OPEN

- Ignition OFF.
- Disconnect: PCM C175b .
- Measure the resistance between dual-function pressure switch [C1078](#) Pin 4, circuit 420 (DB/YE), harness side and PCM [C175B](#) Pin 15, circuit 420 (DB/YE), harness side.

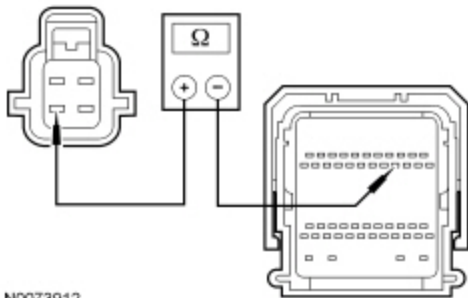

N0073912

Is the resistance less than 5 ohms?

Yes	INSTALL a new dual-function pressure switch. TEST the system for normal operation.
No	REPAIR circuit 420 (DB/YE) for an open. TEST the system for normal operation.

F12 CHECK THE AIR CONDITIONING CLUTCH (WAC/ACCR) PID WITH THE A/C ON

- Enter the following diagnostic mode on the scan tool: WAC/ACCR PCM PID.
- With the engine running, select MAX A/C on the HVAC module.

Does the WAC/ACCR PCM PID read ON?

Yes	GO to F13 .
No	GO to F20 .

F13 CHECK THE GROUND AT THE A/C COMPRESSOR CLUTCH FIELD COIL

- Ignition OFF.
- Disconnect: A/C Compressor Clutch Field Coil C100 .
- Measure the resistance between A/C compressor clutch field coil [C100](#) Pin 2, circuit 1205 (BK), harness side and ground.

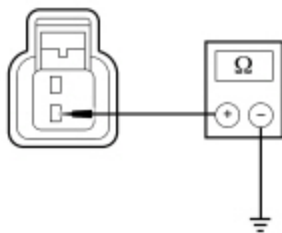

N0003085

Is the resistance less than 5 ohms?

Yes	GO to F14 .
No	REPAIR circuit 1205 (BK) for an open. TEST the system for normal operation.

F14 CHECK THE VOLTAGE AT THE A/C COMPRESSOR CLUTCH FIELD COIL

- Ignition ON.
- Select PANEL mode and press the A/C button on the HVAC module.
- With the engine running, measure the voltage between A/C compressor clutch field coil [C100](#) Pin 1, circuit 883 (PK/LB), harness side and ground.

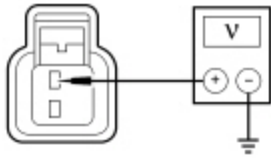

A0048576

Is the voltage greater than 10 volts?

Yes	GO to F15 .
No	GO to F16 .

F15 CHECK THE A/C COMPRESSOR CLUTCH AIR GAP

- Measure the A/C compressor clutch air gap at 3 equally spaced locations between the clutch hub and the A/C compressor clutch pulley.

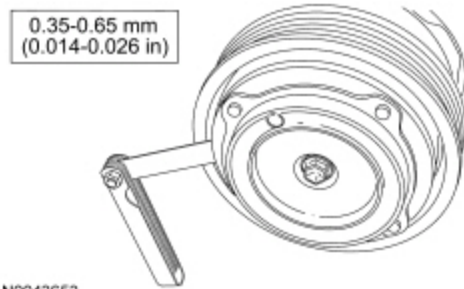

N0043653

Is the A/C compressor clutch air gap average greater than 0.65 mm (0.026 in)?

Yes	ADJUST the A/C compressor clutch gap. REFER to Air Conditioning (A/C) Clutch Air Gap Adjustment in this section. TEST the system for normal operation.
No	INSTALL a new A/C compressor clutch field coil. TEST the system for normal operation.

F16 CHECK VOLTAGE TO RELAY SWITCH

NOTICE: Use the Flex Probe Kit for all test connections to prevent damage to the wiring terminals. Do not use the test probe.

- Ignition OFF.
- Disconnect: A/C Clutch Relay .
- Ignition ON.
- Measure the voltage between A/C control relay socket and ground.

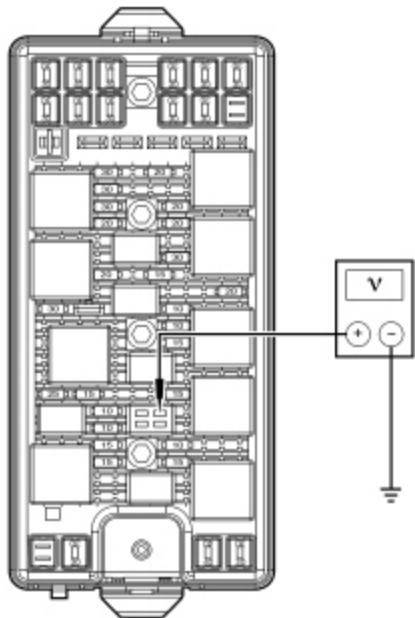

N0040282

Is the voltage greater than 10 volts?

Yes	GO to F17 .
No	VERIFY the Bussed Electrical Center (BEC) fuse 49 (15A) is OK. If OK, INSTALL a new BEC . If not OK, refer to the Wiring Diagrams Manual to identify the possible causes of the circuit short. TEST the system for normal operation.

F17 CHECK CIRCUIT 883 (PK/LB) FOR AN OPEN

NOTICE: Use the Flex Probe Kit for all test connections to prevent damage to the wiring terminals. Do not use the test probe.

- Measure the resistance between A/C control relay socket, circuit 883 (PK/LB) and A/C compressor clutch field coil [C100](#) Pin 1, circuit 883 (PK/LB), harness side.

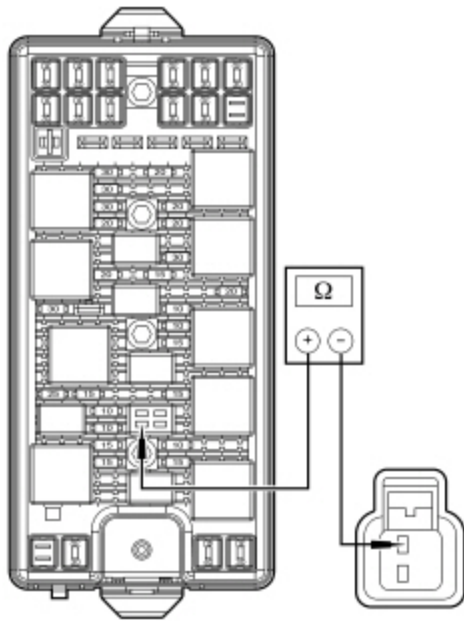

N0051114

Is the resistance less than 5 ohms?

Yes	INSTALL a new A/C control relay. TEST the system for normal operation.
No	REPAIR circuit 883 (PK/LB) for an open. TEST the system for normal operation.

F18 CHECK THE SJB MODULE CONNECTION

- Clear the DTCs.
- Disconnect all the SJB connectors.
- Check for:
 - corrosion.
 - pushed-out pins.
 - incorrectly seated connector.
- Connect and correctly seat all the SJB connectors.
- Operate the system.

Does the concern return?

Yes	INSTALL a new <u>SJB</u> . REFER to Section 419-10 . TEST the system for normal operation.
No	The system is operating correctly at this time. The concern may have been caused by a loose or corroded connector.

F19 CHECK THE MODULE CONNECTION

- Carry out the HVAC Module Cold Boot Process.
- Operate the system.

Does the concern return?

Yes	INSTALL a new HVAC module. REFER to Section 412-01 . TEST the system for normal operation.
No	The system is operating correctly at this time. The concern may have been caused by a loose or corroded connector. TEST the system for normal operation.

F20 CHECK THE PCM MODULE CONNECTION

- Clear the DTCs.
- Disconnect all the PCM connectors.
- Check for:
 - corrosion.
 - pushed-out pins.
 - incorrectly seated connector.
- Connect and correctly seat all the PCM connectors.
- Operate the system.

Does the concern return?

Yes	INSTALL a new PCM. TEST the system for normal operation.
No	The system is operating correctly at this time. The concern may have been caused by a loose or corroded connector.

Pinpoint Test G: The Air Conditioning (A/C) is Always On — A/C Compressor Does Not Cycle

Refer to Wiring Diagrams Cell [54](#) , Manual Climate Control System for schematic and connector information.

Normal Operation

Under normal operation, when A/C is requested, a ground signal is sent from the HVAC module to the Smart Junction Box (SJB) through circuit 1397 (GY/RD). The SJB then transmits an A/C request message through the High Speed Controller Area Network (HS-CAN) bus to the PCM.

4.0L only

Voltage is provided to the A/C cycling switch through circuit 391 (RD/YE). If the A/C cycling switch is closed (sufficient pressure) voltage is sent from the A/C cycling switch to the PCM (4.0L) through circuit 198 (DG/OG)/420 (DB/YE). When the PCM receives voltage from the pressure switch and the A/C pressure transducer does not indicate excessive pressure, the PCM provides a ground for the A/C clutch relay through circuit 321 (GY/WH).

4.6L and 5.4L only

Voltage is provided to the A/C cycling switch through circuit 391 (RD/YE). If the A/C cycling switch is closed (sufficient pressure) voltage is sent from the A/C cycling switch to the dual-function pressure switch (4.6L and 5.4L) through circuit 198 (DG/OG). If the dual-function pressure switch (4.6L and 5.4L) is closed (pressure not excessive), voltage is sent to the PCM through circuit 420 (DB/YE). When the PCM receives voltage from the pressure switches, the PCM provides a ground for the A/C clutch relay through circuit 321 (GY/WH).

When the relay is activated, ignition voltage is supplied to the A/C clutch solenoid through circuit 883 (PK/LB). Ground is supplied for the A/C clutch through circuit 1205 (BK).

- DTC B2175 A/C Request Signal Circuit Short to Ground — The module senses a continuous short to ground on the A/C request circuit.

This pinpoint test is intended to diagnose the following:

- Wiring, terminals or connectors
- PCM
- SJB
- HVAC module
- A/C cycling switch
- A/C control relay
- A/C clutch air gap

PINPOINT TEST G : THE AIR CONDITIONING (A/C) IS ALWAYS ON — A/C COMPRESSOR DOES NOT CYCLE

G1 CHECK THE AIR CONDITIONING REQUEST SIGNAL (AC_REQST) GEM PID

- Ignition ON.
- With the engine running, select the OFF position on the HVAC module.
- Enter the following diagnostic mode on the scan tool: AC_REQST Generic Electronic Module (GEM) PID .

Does the AC_REQST GEM PID read OFF?

Yes	GO to G4 .
No	GO to G2 .

G2 CHECK THE A/C SIGNAL WITH THE A/C OFF

- Ignition OFF.
- Disconnect: SJB C2280a .
- Disconnect: SJB C2280b .
- Ignition ON.
- With the engine running, select the OFF position on the HVAC module.
- Measure the voltage between SJB [C2280B](#) Pin 29, circuit 1397 (GY/RD), harness side and SJB [C2280A](#) Pin 36, circuit 1044 (WH/YE), harness side.

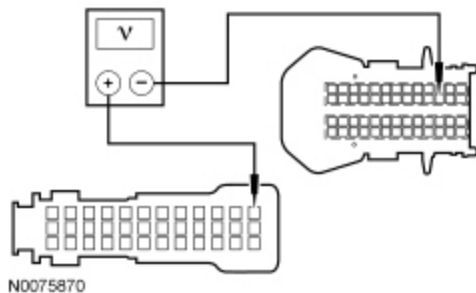

Is the voltage greater than 10 volts?

Yes	GO to G3 .
No	GO to G11 .

G3 CHECK CIRCUIT 1397 (GY/RD) FOR A SHORT TO GROUND

- Ignition OFF.
- Disconnect: HVAC Module C294a .
- Measure the resistance between [SJB C2280B](#) Pin 29, circuit 1397 (GY/RD), harness side and ground.

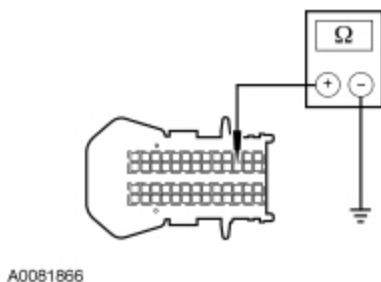

Is the resistance greater than 10,000 ohms?

Yes	GO to G12 .
No	REPAIR circuit 1397 (GY/RD) for a short to ground. TEST the system for normal operation.

G4 CHECK THE AIR CONDITIONING COMPRESSOR CYCLING SWITCH (ACCS) PCM PID WITH THE A/C OFF

- With the engine running, select the OFF position on the HVAC module.
- Enter the following diagnostic mode on the scan tool: ACCS PCM PID .

Does the ACCS PCM PID read OFF?

Yes	GO to G5 .
No	GO to G13 .

G5 CHECK THE AIR CONDITIONING CLUTCH (WAC/ACCR) PID WITH THE A/C OFF

- Enter the following diagnostic mode on the scan tool: WAC/ACCR PCM PID .
- With the engine running, select PANEL mode on the HVAC module and make sure the A/C button is OFF.

Does the WAC/ACCR PCM PID read OFF?

Yes	GO to G6 .
No	GO to G13 .

G6 CHECK THE A/C CLUTCH RELAY

- Ignition OFF.
- Disconnect: A/C Clutch Relay .
- Ignition ON.
- With the engine running, observe the A/C clutch operation.

Does the A/C clutch engage?

Yes	GO to G7 .
No	CARRY OUT the A/C clutch relay component test. Refer to Wiring Diagrams Cell 149 for component testing. If the relay tests OK, GO to G8 .

G7 CHECK CIRCUIT 883 (PK/LB) FOR A SHORT TO VOLTAGE

- Ignition OFF.
- Disconnect: A/C Compressor Clutch Field Coil C100 .
- Ignition ON.
- Measure the voltage between A/C compressor clutch field coil [C100](#) Pin 1, circuit 883 (PK/LB), harness side and ground.

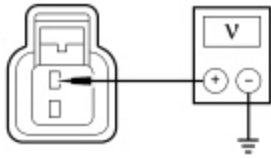

A0048576

Is any voltage present?

Yes	REPAIR circuit 883 (PK/LB) for a short to voltage. TEST the system for normal operation.
No	ADJUST the A/C compressor clutch gap. REFER to Air Conditioning (A/C) Clutch Air Gap Adjustment in this section. TEST the system for normal operation.

G8 CHECK CIRCUIT 420 (DB/YE) FOR VOLTAGE

- Ignition OFF.
- Disconnect: PCM C175b .
- Disconnect: A/C Cycling Switch C130 .
- Ignition ON.
- Measure the voltage between PCM [C175B](#) Pin 15, circuit 420 (DB/YE), harness side and ground.

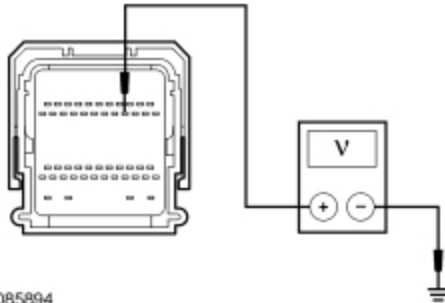

A0085894

Is any voltage present?

Yes	For 4.0L, REPAIR circuit 420 (DB/YE)/198 (DG/OG) for a short to voltage. TEST the system for normal operation. For 4.6L and 5.4L, GO to G10 .
No	GO to G9 .

G9 CHECK THE A/C CYCLING SWITCH

- Ignition OFF.

- Remove the A/C cycling switch from the vehicle.
- Measure the resistance between the A/C cycling switch pins.

Is the resistance greater than 10,000 ohms?

Yes	GO to G13 .
No	INSTALL a new A/C cycling switch. TEST the system for normal operation.

G10 CHECK FOR A SHORT TO VOLTAGE

- Ignition OFF.
- Disconnect: Dual-Function Pressure Switch C1078 .
- Ignition ON.
- Measure the voltage between PCM [C175B](#) Pin 15, circuit 420 (DB/YE), harness side and ground.

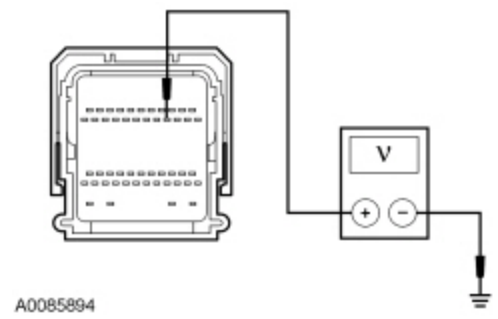

Is any voltage present?

Yes	REPAIR circuit 420 (DB/YE) for a short to voltage. TEST the system for normal operation.
No	REPAIR circuit 198 (DG/OG) for a short to voltage. TEST the system for normal operation.

G11 CHECK THE SJB MODULE CONNECTION

- Clear the DTCs.
- Disconnect all the SJB connectors.
- Check for:
 - corrosion.
 - pushed-out pins.
 - incorrectly seated connector.
- Connect and correctly seat all the SJB connectors.
- Operate the system.

Does the concern return?

Yes	INSTALL a new <u>SJB</u> . REFER to Section 419-10 . TEST the system for normal operation.
------------	--

No	The system is operating correctly at this time. The concern may have been caused by a loose or corroded connector.
-----------	--

G12 CHECK THE MODULE CONNECTION

- Carry out the HVAC Module Cold Boot Process.
- Operate the system.

Does the concern return?

Yes	INSTALL a new HVAC module. REFER to Section 412-01 . TEST the system for normal operation.
No	The system is operating correctly at this time. The concern may have been caused by a loose or corroded connector. TEST the system for normal operation.

G13 CHECK THE PCM MODULE CONNECTION

- Clear the DTCs.
- Disconnect all the PCM connectors.
- Check for:
 - corrosion.
 - pushed-out pins.
 - incorrectly seated connector.
- Connect and correctly seat all the PCM connectors.
- Operate the system.

Does the concern return?

Yes	INSTALL a new PCM. TEST the system for normal operation.
No	The system is operating correctly at this time. The concern may have been caused by a loose or corroded connector.

Pinpoint Test H: The Air Conditioning (A/C) is Always On — A/C Mode Always Commanded ON

Refer to Wiring Diagrams Cell [54](#) , Manual Climate Control System for schematic and connector information.

Normal Operation

Under normal operation, when A/C is requested, a ground signal is sent from the HVAC module to the Smart Junction Box (SJB) through circuit 1397 (GY/RD). The [SJB](#) then transmits an A/C request message through the High Speed Controller Area Network (HS-CAN) bus to the PCM.

4.0L only

Voltage is provided to the A/C cycling switch through circuit 391 (RD/YE). If the A/C cycling switch is closed (sufficient pressure) voltage is sent from the A/C cycling switch to the PCM (4.0L) through circuit 198 (DG/OG)/420 (DB/YE). When the PCM receives voltage from the pressure switch and the A/C pressure transducer does not indicate excessive

pressure, the PCM provides a ground for the A/C clutch relay through circuit 321 (GY/WH).

4.6L and 5.4L only

Voltage is provided to the A/C cycling switch through circuit 391 (RD/YE). If the A/C cycling switch is closed (sufficient pressure) voltage is sent from the A/C cycling switch to the dual-function pressure switch (4.6L and 5.4L) through circuit 198 (DG/OG). If the dual-function pressure switch (4.6L and 5.4L) is closed (pressure not excessive), voltage is sent to the PCM through circuit 420 (DB/YE). When the PCM receives voltage from the pressure switches, the PCM provides a ground for the A/C clutch relay through circuit 321 (GY/WH).

When the relay is activated, ignition voltage is supplied to the A/C clutch solenoid through circuit 883 (PK/LB). Ground is supplied for the A/C clutch through circuit 1205 (BK).

- DTC B2175 A/C Request Signal Circuit Short to Ground — The module senses a continuous short to ground on the A/C request circuit.

This pinpoint test is intended to diagnose the following:

- Wiring, terminals or connectors
- PCM
- [SJB](#)
- HVAC module
- A/C cycling switch
- A/C control relay
- A/C clutch air gap

PINPOINT TEST H : THE AIR CONDITIONING (A/C) IS ALWAYS ON — A/C MODE ALWAYS COMMANDED ON

H1 CHECK THE AIR CONDITIONING REQUEST SIGNAL (AC_REQST) GEM PID

- Ignition ON.
- With the engine running, select the OFF position on the HVAC module.
- Enter the following diagnostic mode on the scan tool: AC_REQST Generic Electronic Module (GEM) PID .

Does the AC_REQST GEM PID read OFF?

Yes	GO to H4 .
No	GO to H2 .

H2 CHECK THE A/C SIGNAL WITH THE A/C OFF

- Ignition OFF.
- Disconnect: [SJB C2280a](#) .
- Disconnect: [SJB C2280b](#) .
- Ignition ON.
- With the engine running, select the OFF position on the HVAC module.
- Measure the voltage between [SJB C2280B](#) Pin 29, circuit 1397 (GY/RD), harness side and [SJB C2280A](#) Pin 36, circuit 1044 (WH/YE), harness side.

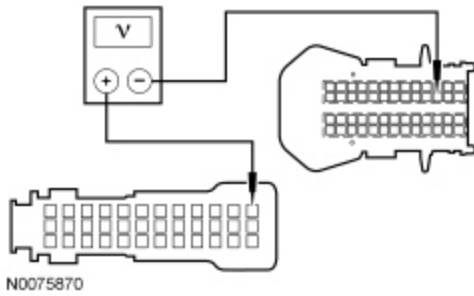

Is the voltage greater than 10 volts?

Yes	GO to H3 .
No	GO to H11 .

H3 CHECK CIRCUIT 1397 (GY/RD) FOR A SHORT TO GROUND

- Ignition OFF.
- Disconnect: HVAC Module C294a .
- Measure the resistance between [SJB C2280B](#) Pin 29, circuit 1397 (GY/RD), harness side and ground.

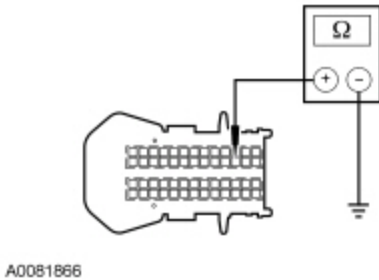

Is the resistance greater than 10,000 ohms?

Yes	GO to H12 .
No	REPAIR circuit 1397 (GY/RD) for a short to ground. TEST the system for normal operation.

H4 CHECK THE AIR CONDITIONING COMPRESSOR CYCLING SWITCH (ACCS) PCM PID WITH THE A/C OFF

- With the engine running, select the OFF position on the HVAC module.
- Enter the following diagnostic mode on the scan tool: ACCS PCM PID .

Does the ACCS PCM PID read OFF?

Yes	GO to H5 .
No	GO to H13 .

H5 CHECK THE AIR CONDITIONING CLUTCH (WAC/ACCR) PCM PID WITH THE A/C OFF

- Enter the following diagnostic mode on the scan tool: WAC/ACCR PCM PID .
- With the engine running, select PANEL mode on the HVAC module and make sure the A/C button is OFF.

Does the WAC/ACCR PCM PID read OFF?

Yes	GO to H6 .
No	GO to H13 .

H6 CHECK THE A/C CLUTCH RELAY

- Ignition OFF.
- Disconnect: A/C Clutch Relay .
- Ignition ON.
- With the engine running, observe the A/C clutch operation.

Does the A/C clutch engage?

Yes	GO to H7 .
No	CARRY OUT the A/C clutch relay component test. Refer to Wiring Diagrams Cell 149 for component testing. If the relay tests OK, GO to H8 .

H7 CHECK CIRCUIT 883 (PK/LB) FOR A SHORT TO VOLTAGE

- Ignition OFF.
- Disconnect: A/C Compressor Clutch Field Coil C100 .
- Ignition ON.
- Measure the voltage between A/C compressor clutch field coil [C100](#) Pin 1, circuit 883 (PK/LB), harness side and ground.

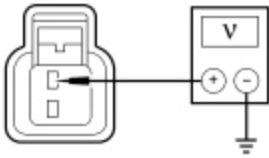

A0048576

Is any voltage present?

Yes	REPAIR circuit 883 (PK/LB) for a short to voltage. TEST the system for normal operation.
No	ADJUST the A/C compressor clutch gap. REFER to Air Conditioning (A/C) Clutch Air Gap Adjustment in this section. TEST the system for normal operation.

H8 CHECK CIRCUIT 420 (DB/YE) FOR VOLTAGE

- Ignition OFF.
- Disconnect: PCM C175b .
- Disconnect: A/C Cycling Switch C130 .
- Ignition ON.
- Measure the voltage between PCM [C175B](#) Pin 15, circuit 420 (DB/YE), harness side and ground.

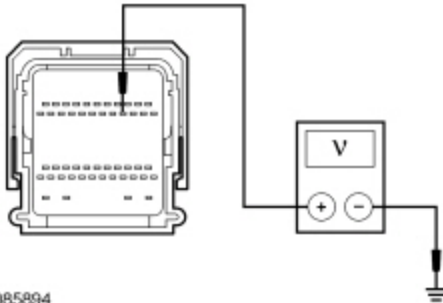

A0085894

Is any voltage present?

Yes	For 4.0L, REPAIR circuit 420 (DB/YE)/198 (DG/OG) for a short to voltage. TEST the system for normal operation. For 4.6L and 5.4L, GO to H10 .
No	GO to H9 .

H9 CHECK THE A/C CYCLING SWITCH

- Ignition OFF.

- Remove the A/C cycling switch from the vehicle.
- Measure the resistance between the A/C cycling switch pins.

Is the resistance greater than 10,000 ohms?

Yes	GO to H13 .
No	INSTALL a new A/C cycling switch. TEST the system for normal operation.

H10 CHECK FOR A SHORT TO VOLTAGE

- Ignition OFF.
- Disconnect: Dual-Function Pressure Switch C1078 .
- Ignition ON.
- Measure the voltage between PCM [C175B](#) Pin 15, circuit 420 (DB/YE), harness side and ground.

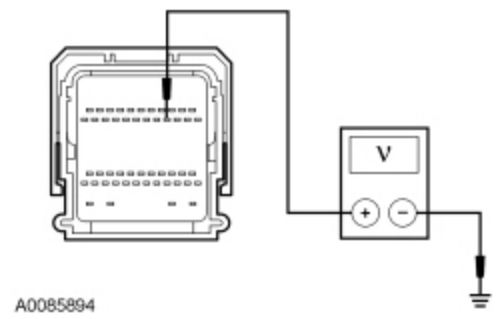

A0085894

Is any voltage present?

Yes	REPAIR circuit 420 (DB/YE) for a short to voltage. TEST the system for normal operation.
No	REPAIR circuit 198 (DG/OG) for a short to voltage. TEST the system for normal operation.

H11 CHECK THE SJB MODULE CONNECTION

- Clear the DTCs.
- Disconnect all the SJB connectors.
- Check for:
 - corrosion.
 - pushed-out pins.
 - incorrectly seated connector.
- Connect and correctly seat all the SJB connectors.
- Operate the system.

Does the concern return?

Yes	INSTALL a new <u>SJB</u> . REFER to Section 419-10 . TEST the system for normal operation.
------------	--

No	The system is operating correctly at this time. The concern may have been caused by a loose or corroded connector.
-----------	--

H12 CHECK THE MODULE CONNECTION

- Carry out the HVAC Module Cold Boot Process.
- Operate the system.

Does the concern return?

Yes	INSTALL a new HVAC module. REFER to Section 412-01 . TEST the system for normal operation.
No	The system is operating correctly at this time. The concern may have been caused by a loose or corroded connector. TEST the system for normal operation.

H13 CHECK THE PCM MODULE CONNECTION

- Clear the DTCs.
- Disconnect all the PCM connectors.
- Check for:
 - corrosion.
 - pushed-out pins.
 - incorrectly seated connector.
- Connect and correctly seat all the PCM connectors.
- Operate the system.

Does the concern return?

Yes	INSTALL a new PCM. TEST the system for normal operation.
No	The system is operating correctly at this time. The concern may have been caused by a loose or corroded connector.

Pinpoint Test I: The Blower Motor is Inoperative

Refer to Wiring Diagrams Cell [54](#) , Manual Climate Control System for schematic and connector information.

Normal Operation

Under normal operation, the blower motor relay coil receives ignition voltage. The coil receives ground from the HVAC module through circuit 364 (BK/LG) if any position but OFF is selected. Voltage is supplied to the relay switch contact. When the relay coil is energized, voltage is delivered to the blower motor through circuit 371 (PK/WH). Ground for the blower motor is provided through circuit 261 (OG/BK) from the blower resistor or the blower switch (HI). The blower resistor and blower switch is grounded through circuit 1205 (BK).

This pinpoint test is intended to diagnose the following:

- Wiring, terminals or connectors
- Blower motor
- Blower motor relay
- Blower motor switch

PINPOINT TEST I : THE BLOWER MOTOR IS INOPERATIVE

NOTICE: It is important to install relays in their correct position in the Bussed Electrical Center (BEC) . Installing a relay incorrectly may cause wiring shorts or damage to modules. While carrying out diagnostics on BEC relays, have only one BEC relay removed at a time. Failure to follow these instructions may result in damage to the vehicle circuitry or to control modules.

I1 CHECK CIRCUIT 261 (OG/BK) FOR GROUND

- Disconnect: Blower Motor C2066 .
- Turn the function selector switch to the PANEL position.
- Turn the blower motor switch to the high position.
- Measure the resistance between blower motor connector C2066 Pin 2, circuit 261 (OG/BK), harness side and ground.

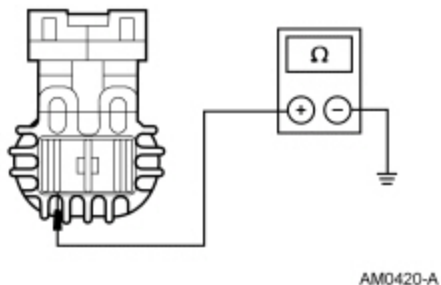

Is the resistance less than 5 ohms?

Yes	GO to I4 .
No	GO to I2 .

I2 CHECK CIRCUIT 261 (OG/BK) FOR AN OPEN

- Disconnect: Blower Motor Switch C294b .
- Measure the resistance between blower motor switch C294B Pin 2, circuit 261 (OG/BK), harness side and blower motor C2066 Pin 2, circuit 261 (OG/BK), harness side.

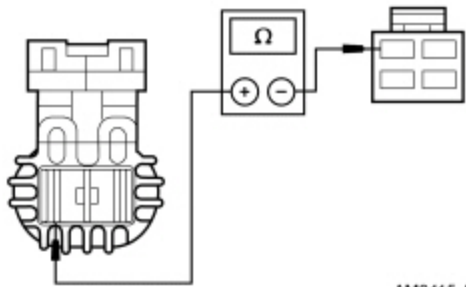

AM0415-A

Is the resistance less than 5 ohms?

Yes	GO to I3 .
No	REPAIR circuit 261 (OG/BK) for an open. TEST the system for normal operation.

I3 CHECK CIRCUIT 1205 (BK) FOR AN OPEN

- Measure the resistance between blower motor switch [C294B](#) Pin 1, circuit 1205 (BK), harness side and ground.

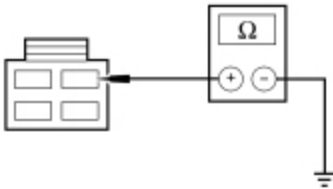

A0040182

Is the resistance less than 5 ohms?

Yes	INSTALL a new blower motor switch. TEST the system for normal operation.
No	REPAIR circuit 1205 (BK) for an open. TEST the system for normal operation.

I4 CHECK BLOWER MOTOR CIRCUIT 371 (PK/WH) FOR VOLTAGE

- Ignition ON.
- Measure the voltage between blower motor connector [C2066](#) Pin 1, circuit 371 (PK/WH), harness side and ground.

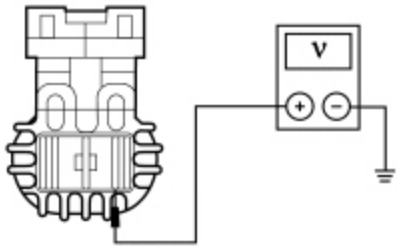

AM0416-A

Is the voltage greater than 10 volts?

Yes	INSTALL a new blower motor. TEST the system for normal operation.
No	GO to 15 .

15 CHECK CIRCUIT 371 (PK/WH) FOR AN OPEN

NOTICE: Use the Flex Probe Kit for all test connections to prevent damage to the wiring terminals. Do not use the test probe.

- Ignition OFF.
- Disconnect: Blower Motor Relay .
- Measure the resistance between blower motor relay socket, circuit 371 (PK/WH) and blower motor [C2066](#) Pin 1, circuit 371 (PK/WH), harness side.

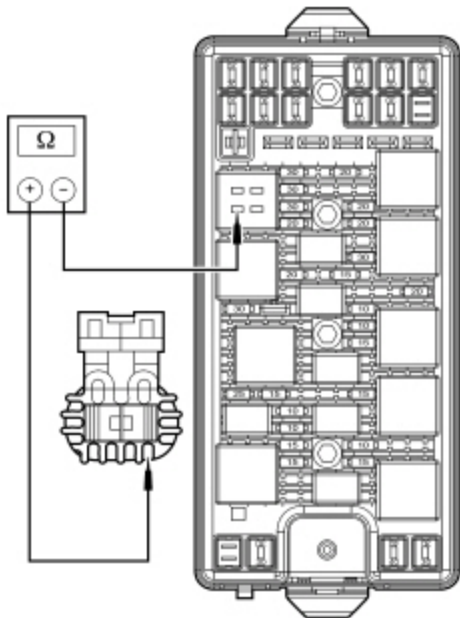

N0040284

Is the resistance less than 5 ohms?

Yes	GO to 16 .
No	REPAIR circuit 371 (PK/WH) for an open. TEST the system for normal operation.

16 CHECK THE BLOWER MOTOR RELAY

NOTICE: Use the Flex Probe Kit for all test connections to prevent damage to the wiring terminals. Do not use the test probe.

- Connect: Blower Motor C2066 .
- Ignition ON.
- Connect a fused jumper lead between blower motor relay socket and blower motor relay socket, circuit 371 (PK/WH).

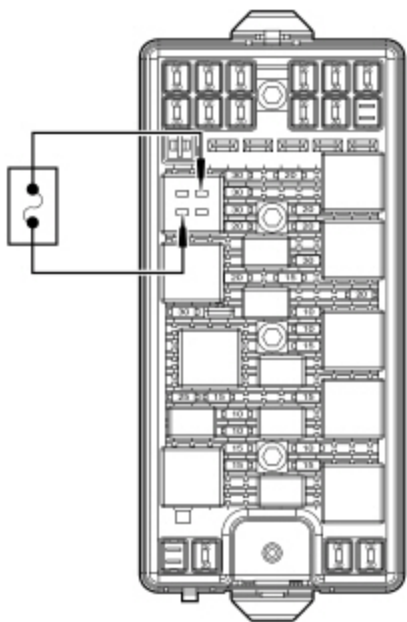

N0040285

Does the blower motor operate?

Yes	GO to 17 .
No	VERIFY Bussed Electrical Center (BEC) fuse 2 (30A) is OK. If OK, INSTALL a new <u>BEC</u> . If not OK, refer to the Wiring Diagrams Manual to identify the possible causes of the circuit short. TEST the system for normal operation.

17 CHECK THE RELAY COIL SUPPLY VOLTAGE

NOTICE: Use the Flex Probe Kit for all test connections to prevent damage to the wiring terminals. Do not use the test probe.

- Measure the voltage between blower motor relay socket, circuit 1322 (BN/WH) and ground.

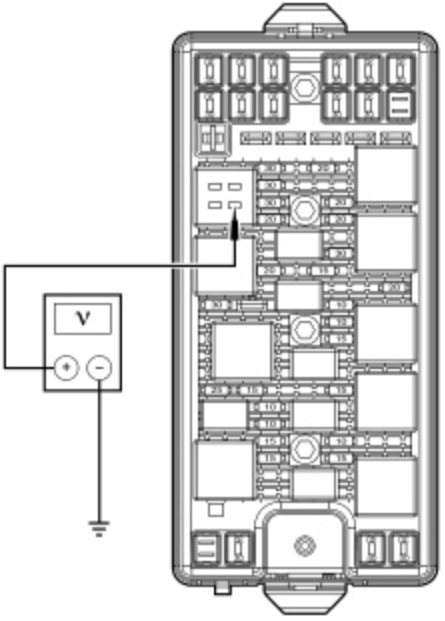

N0040286

Is the voltage greater than 10 volts?

Yes	GO to 18 .
No	VERIFY the Smart Junction Box (SJB) fuse 3 (10A) is OK. If OK, REPAIR circuit 1322 (BN/WH) for an open. If not OK, REFER to the Wiring Diagrams Manual to identify the possible causes of the circuit short. TEST the system for normal operation.

18 CHECK THE BLOWER MOTOR RELAY

NOTICE: Use the Flex Probe Kit for all test connections to prevent damage to the wiring terminals. Do not use the test probe.

- Ignition ON.
- Measure the voltage between blower motor relay socket, circuit 364 (BK/LG) and socket blower motor relay, circuit 1322 (BN/WH).

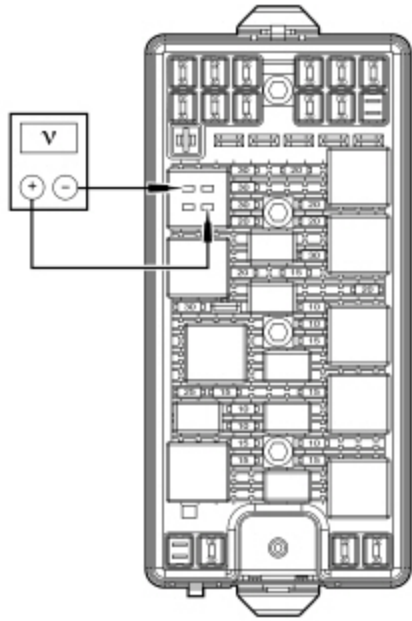

N0040287

Is the voltage greater than 10 volts?

Yes	INSTALL a new blower motor relay. TEST the system for normal operation.
No	GO to I9 .

I9 CHECK CIRCUIT 364 (BK/LG) FOR AN OPEN

NOTICE: Use the Flex Probe Kit for all test connections to prevent damage to the wiring terminals. Do not use the test probe.

- Ignition OFF.
- Disconnect: HVAC module C294a .
- Measure the resistance between blower motor relay socket, circuit 364 (BK/LG) and HVAC module [C294A](#) Pin 23, circuit 364 (BK/LG), harness side.

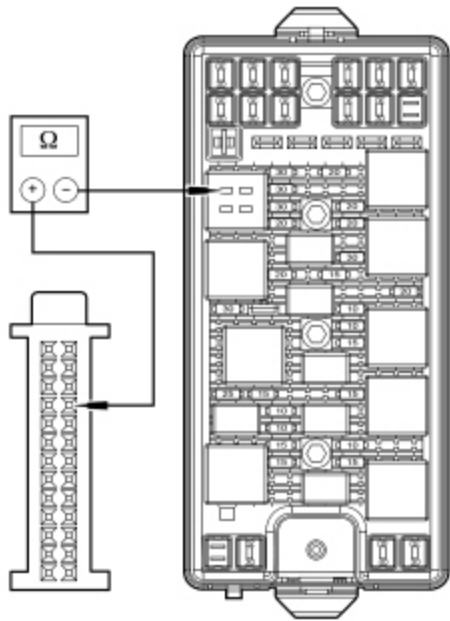

N0040288

Is the resistance less than 5 ohms?

Yes	GO to 110 .
No	REPAIR circuit 364 (BK/LG) for an open. TEST the system for normal operation.

110 CHECK THE MODULE CONNECTION

- Carry out the HVAC Module Cold Boot Process.
- Operate the system.

Does the concern return?

Yes	INSTALL a new HVAC module. REFER to Section 412-01 . TEST the system for normal operation.
No	The system is operating correctly at this time. The concern may have been caused by a loose or corroded connector. TEST the system for normal operation.

Pinpoint Test J: The Blower Motor Does Not Operate Correctly

Refer to Wiring Diagrams Cell [54](#) , Manual Climate Control System for schematic and connector information.

Normal Operation

Under normal operation, the blower motor is provided a ground from the blower resistor through circuit 261 (OG/BK). The resistor gets a ground from circuit 1205 (BK) in the lowest blower setting. In MED-LO and MED-HI, the resistor gets a ground through circuit 754 (LG/WH) or 752 (YE/RD), depending on selected speed. In HI, the blower motor is grounded directly through the blower switch from circuit 261 (OG/BK) to circuit 1205 (BK). The blower switch receives its ground from circuit 1205 (BK).

This pinpoint test is intended to diagnose the following:

- Wiring, terminals or connectors
- Blower motor resistor
- Blower motor switch

PINPOINT TEST J : THE BLOWER MOTOR DOES NOT OPERATE CORRECTLY

J1 CHECK THE BLOWER MOTOR OPERATION

- Ignition ON.
- Turn the function selector switch to the FLOOR position.
- Select all blower speed positions.

Does the blower motor operate in any speed position?

Yes	If the blower motor does not operate in HI setting only, GO to J2 . If the blower motor does not operate in LO setting only, GO to J3 . If the blower motor does not operate in MED-LO or MED-HI setting only, GO to J4 . If the blower motor operates in HI setting only, GO to J6 . If the blower motor operates in LO setting only, GO to J7 . For all other symptoms, GO to J8 .
No	GO to Pinpoint Test I.

J2 CHECK CIRCUIT 261 (OG/BK) FOR AN OPEN

- Ignition OFF.
- Disconnect: Blower Motor Switch C294b .
- Disconnect: Blower Motor C2066 .
- Measure the resistance between blower motor switch [C294B](#) Pin 2, circuit 261 (OG/BK) and blower motor [C2066](#) Pin 2, circuit 261 (OG/BK).

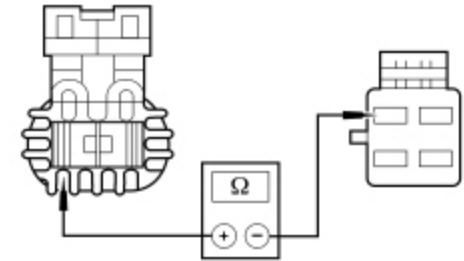

N0095887

Is the resistance less than 5 ohms?

Yes	INSTALL a new blower motor switch. TEST the system for normal operation.
No	REPAIR circuit 261 (OG/BK) for an open. TEST the system for normal operation.

J3 CHECK BLOWER MOTOR RESISTOR GROUND CIRCUIT 1205 (BK) FOR AN OPEN

- Ignition OFF.
- Disconnect: Blower Motor Resistor C2185 .
- Measure the resistance between blower motor resistor [C2185](#) Pin 4, circuit 1205 (BK) and ground.

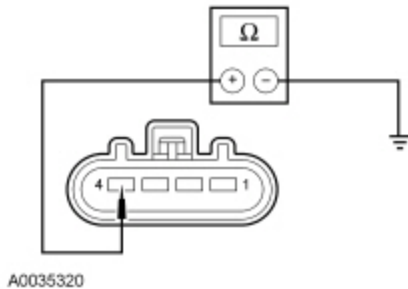

Is the resistance less than 5 ohms?

Yes	INSTALL a new blower motor resistor. TEST the system for normal operation.
No	REPAIR circuit 1205 (BK) for an open. TEST the system for normal operation.

J4 CHECK CIRCUIT 752 (YE/RD) OR 754 (LG/WH) FOR AN OPEN

NOTICE: Use the Flex Probe Kit for all test connections to prevent damage to the wiring terminals. Do not use the test lamp probe.

- Ignition OFF.
- Disconnect: Blower Motor Resistor C2185 .
- Ignition ON.
- For MED-LO inoperative

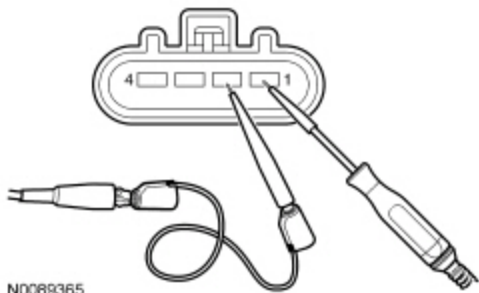

For MED-LO inoperative: With the blower motor switch in the MED-LO speed position, connect a 12-volt test lamp between blower motor resistor [C2185](#) Pin 2, circuit 261 (OG/BK), harness side and blower motor resistor [C2185](#) Pin 1, circuit 752 (YE/RD), harness side.

- **For MED-HI inoperative**

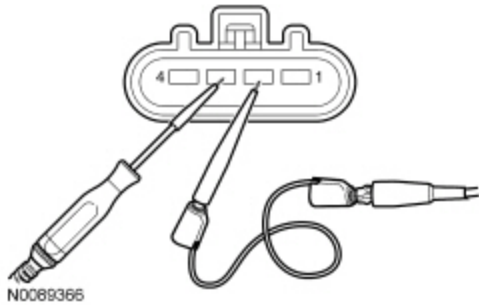

For MED-HI inoperative: With the blower motor switch in the MED-HI speed position, connect a 12-volt test lamp between blower motor resistor [C2185](#) Pin 2, circuit 261 (OG/BK), harness side and blower motor resistor [C2185](#) Pin 3, circuit 754 (LG/WH), harness side.

Does the test lamp illuminate?

Yes	INSTALL a new blower motor resistor. TEST the system for normal operation.
No	GO to J5 .

J5 CHECK CIRCUIT 752 (YE/RD) OR 754 (LG/WH) FOR AN OPEN

- Ignition OFF.
- Disconnect: Blower Motor Switch C294b .

- **For MED-LO inoperative**

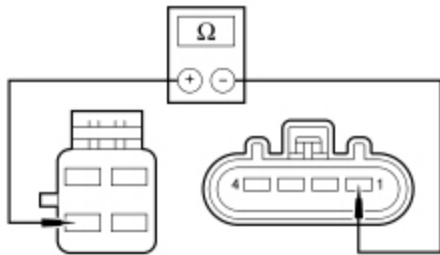

For MED-LO inoperative, measure the resistance between blower motor switch [C294B](#) Pin 4, circuit 752 (YE/RD), harness side and blower motor resistor [C2185](#) Pin 1, circuit 752 (YE/RD), harness side.

- **For MED-HI inoperative**

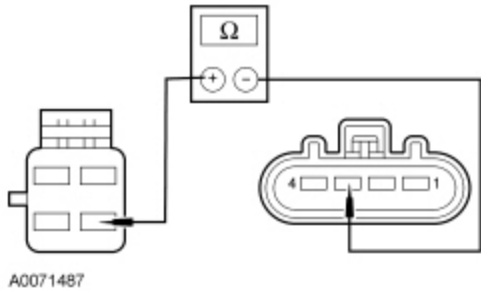

For **MED-HI inoperative**, measure the resistance between blower motor switch [C294B](#) Pin 3, circuit 754 (LG/WH), harness side and blower motor resistor [C2185](#) Pin 3, circuit 754 (LG/WH), harness side.

Is the resistance less than 5 ohms?

Yes	CARRY OUT the Blower Motor Resistor component test in this section. If the resistor tests OK, INSTALL a new blower motor switch. TEST the system for normal operation.
No	REPAIR circuit 752 (YE/RD) or 754 (LG/WH) for an open. TEST the system for normal operation.

J6 CHECK BLOWER MOTOR RESISTOR CIRCUIT 261 (OG/BK) FOR AN OPEN

- Ignition OFF.
- Disconnect: Blower Motor Resistor C2185 .
- Connect: Blower Motor C2066 .
- Measure the resistance between blower motor resistor [C2185](#) Pin 2, circuit 261 (OG/BK) and blower motor [C2066](#) Pin 2, circuit 261 (OG/BK).

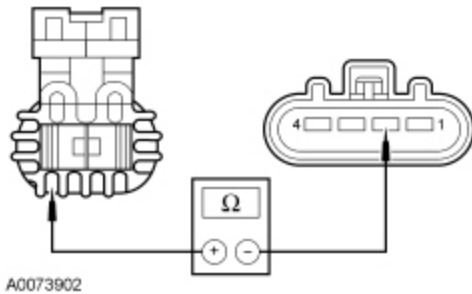

Is the resistance less than 5 ohms?

Yes	INSTALL a new blower motor resistor. TEST the system for normal operation.
No	REPAIR circuit 261 (OG/BK) for an open. TEST the system for normal operation.

J7 CHECK BLOWER MOTOR SWITCH CIRCUIT 1205 (BK) FOR AN OPEN

- Ignition OFF.
- Disconnect: Blower Motor Switch C294b .
- Measure the resistance between blower motor switch [C294B](#) Pin 1, circuit 1205 (BK) and ground.

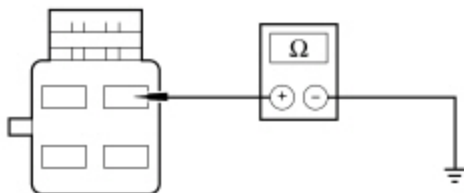

A0020414

Is the resistance less than 5 ohms?

Yes	INSTALL a new blower motor switch. TEST the system for normal operation.
No	REPAIR circuit 1205 (BK) for an open. TEST the system for normal operation.

J8 CHECK CIRCUITS 261 (OG/BK), 752 (YE/RD) AND 754 (LG/WH) FOR A SHORT TO GROUND

- Ignition OFF.
- Disconnect: Blower Motor C2066 .
- Disconnect: Blower Motor Switch C294b .
- Disconnect: Blower Motor Resistor C2185 .
- Measure the resistance between ground and blower motor resistor C2185, circuit:
 - 752 (YE/RD) pin 1
 - 261 (OG/BK) pin 2
 - 754 (LG/WH) pin 3

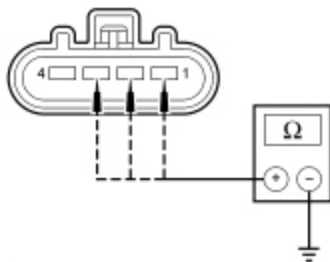

A0051664

Are the resistances greater than 10,000 ohms?

Yes	GO to J9 .
No	REPAIR the affected circuit. TEST the system for normal operation.

J9 CHECK THE BLOWER MOTOR CIRCUITS FOR SHORTS TOGETHER

- Measure the resistance between blower motor resistor C2185:
 - pin 1, circuit 752 (YE/RD) and pin 2, circuit 261 (OG/BK).
 - pin 1, circuit 752 (YE/RD) and pin 3, circuit 754 (LG/WH).
 - pin 2, circuit 261 (OG/BK) and pin 3, circuit 754 (LG/WH).

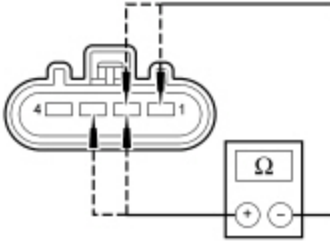

A0051665

Are the resistances greater than 10,000 ohms?

Yes	CARRY OUT the Blower Motor Resistor component test in this section. If the resistor tests OK, INSTALL a new blower motor switch. TEST the system for normal operation.
No	REPAIR the affected circuits. TEST the system for normal operation.

Pinpoint Test K: HVAC Functions Verification

This pinpoint test is intended to diagnose the following:

- Incorrect functioning of the HVAC system

PINPOINT TEST K : HVAC FUNCTIONS VERIFICATION

K1 CARRY OUT THE MODULES SELF-TESTS

- Ignition ON.
- Carry out the Smart Junction Box (SJB) and PCM modules self-tests. Record the DTCs displayed, if any.

Were any DTCs displayed as a result of the self-tests?

Yes	REFER to the Smart Junction Box (SJB) DTC Chart or PCM DTC Chart. CARRY OUT the necessary diagnosis and REPAIR as required.
No	GO to K2 .

K2 CHECK THE BLOWER MOTOR OPERATION

- Select PANEL mode.
- Observe blower motor operation and select each blower motor speed.

Does the blower motor operate in all selections and change speed in each?

Yes	GO to K3 .
No	If the blower motor does not operate in any setting, GO to Pinpoint Test I . If the blower motor does not properly change speeds or shut OFF, GO to Pinpoint Test J .

K3 CHECK AIRFLOW OPERATION

- Select the highest blower motor setting.
- **NOTE:** Refer to [Climate Control System](#) in Description and Operation for proper airflow descriptions.
While observing the airflow, select each of the airflow positions (PANEL, PANEL/FLOOR, FLOOR, FLOOR/DEFROST, DEFROST).

Is the airflow directed to the proper outlets?

Yes	GO to K4 .
No	GO to Pinpoint Test D .

K4 VERIFY TEMPERATURE CONTROL OPERATION

- Start the vehicle and allow it to reach normal operating temperature.
- With the A/C OFF, select PANEL mode.
- Change the temperature setting from the coldest to the warmest and back to the coldest

Does the temperature change between very warm to cool?

Yes	GO to K5 .
No	If the temperature does not get very warm, GO to Pinpoint Test E . If the temperature does not change at all, GO to Pinpoint Test D .

K5 VERIFY THE A/C CLUTCH DOES NOT ENGAGE WITH A/C OFF

- With the A/C OFF, select PANEL mode.
- Select the coldest temperature setting.

Is the outlet temperature close to ambient temperature?

Yes	GO to K6 .
No	If the temperature is warmer than ambient temperature, GO to Pinpoint Test D and diagnose for inoperative blend door. If the outlet temperature is significantly colder than ambient temperature and the A/C compressor clutch cycles normally, GO to Pinpoint Test

G.
H.

If the outlet temperature is significantly colder than ambient temperature and the A/C compressor clutch does not cycle, [GO to Pinpoint Test](#)

K6 VERIFY A/C CLUTCH ENGAGEMENT IN THE A/C MODE

- Make sure the ambient air temperature is above 2°C (35°F).
- Select PANEL mode.
- Press the A/C button (indicator ON).

Does the A/C clutch engage when the PANEL and A/C button (indicator ON) is pressed?

Yes	GO to K7 .
No	GO to Pinpoint Test F .

K7 CHECK THE RECIRC OPERATION

- Press the RECIRC button (indicator OFF).
- Select PANEL mode.
- Select the highest blower motor setting.
- Observe airflow noise.
- Press the RECIRC button (indicator ON).

Does the airflow noise increase when the RECIRC mode is selected (indicator ON)?

Yes	The system is operating normally.
No	GO to Pinpoint Test C .

Pinpoint Test L: Temperature Control is Inoperative/Does Not Operate Correctly

Refer to Wiring Diagrams Cell [54](#) , Manual Climate Control System for schematic and connector information.

Normal Operation

Under normal operation, to rotate the mode door actuator clockwise, the HVAC module supplies voltage to the BLEND door actuator motor through circuit 1376 (BK/LB), and supplies ground through circuit 1375 (PK/YE). To rotate the mode door actuator counterclockwise, the HVAC module reverses the voltage and ground circuits.

The blend door actuator feedback resistors are supplied a ground from the HVAC module by circuit 438 (RD/WH) and a 5-volt reference voltage on circuit 436 (RD/LG). The HVAC module reads the voltage on circuit 437 (YE/LG) to determine the blend door actuator position by the position of the actuator feedback resistor wiper arm.

This pinpoint test is intended to diagnose the following:

- An open, short to voltage, ground or together in door actuator open, close, return, reference or feedback circuits
- Blend, air inlet, defrost and floor/panel mode door actuator motor
- HVAC module
- Manual climate control module
- Stuck or bound linkage or door

PINPOINT TEST L : TEMPERATURE CONTROL IS INOPERATIVE/DOES NOT OPERATE CORRECTLY

L1 CHECK THE FEEDBACK POTENTIOMETER TOTAL RESISTANCE

NOTICE: Use the correct size flex probe from the Flex Probe Kit for all test connections. The use of the correct size flex probe is critical to avoid damage to the connector terminals.

NOTE: Check all electrical connectors for proper seating before disconnecting. If incorrectly seated, reseal and lock the connector. Test the system operation. If the condition remains, continue with this test.

- Disconnect: HVAC Module C294a .
- Measure the resistance between HVAC module [C294A](#) Pin 5, circuit 436 (RD/LG) and HVAC module [C294A](#) Pin 15, circuit 438 (RD/WH).

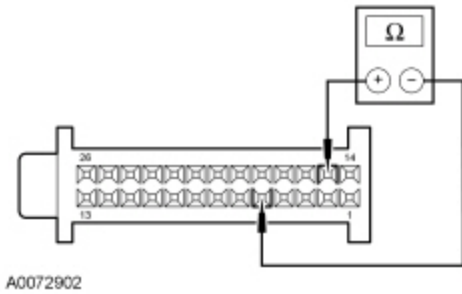

Is the resistance greater than 500 ohms?

Yes	GO to L2 .
No	REPAIR circuits 436 (RD/LG) and 438 (RD/WH) for a short together. TEST the system for normal operation.

L2 CHECK THE POTENTIOMETER LOW- AND HIGH-SIDE RESISTANCE

- Measure the **low-side** resistance between HVAC module [C294A](#) Pin 15, circuit 438 (RD/WH) and HVAC module [C294A](#) Pin 18, circuit 437 (YE/LG).

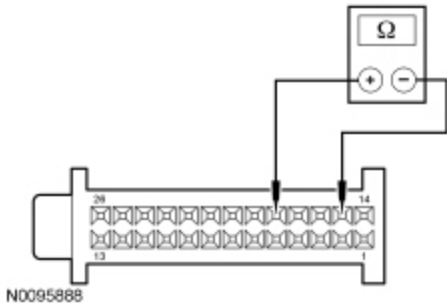

- Measure the **high-side** resistance between HVAC module [C294A](#) Pin 5, circuit 436 (RD/LG) and HVAC module [C294A](#) Pin 18, circuit 437 (YE/LG).

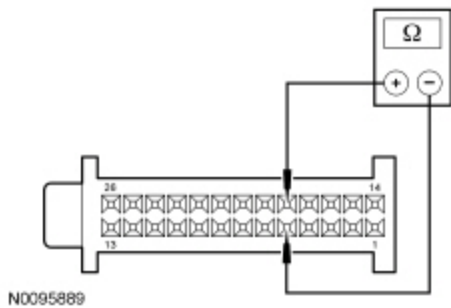

N0095889

Is the resistance between 225 and 11,275 ohms?

Yes	GO to L3 .
No	<p>CARRY OUT the Temperature Blend Door Actuator Component Test in this section. If the actuator tests OK and:</p> <p>If the low-side resistance only is greater than 11,275 ohms, REPAIR circuit 438 (RD/WH) for an open. CLEAR the DTCs. REPEAT the self-test. TEST the system for normal operation.</p> <p>If the low-side resistance only is less than 225 ohms, REPAIR circuits 437 (YE/LG) and 438 (RD/WH) for a short together. CLEAR the DTCs. REPEAT the self-test. TEST the system for normal operation.</p> <p>If the high-side resistance only is greater than 11,275 ohms, REPAIR circuit 436 (RD/LG) for an open. CLEAR the DTCs. REPEAT the self-test. TEST the system for normal operation.</p> <p>If the high-side resistance only is less than 225 ohms, REPAIR circuits 437 (YE/LG) and 436 (RD/LG) for a short together. CLEAR the DTCs. REPEAT the self-test. TEST the system for normal operation.</p> <p>If the high-side and low-side resistance is greater than 11,275 ohms, REPAIR circuit 437 (YE/LG) for an open. CLEAR the DTCs. REPEAT the self-test. TEST the system for normal operation.</p>

L3 CHECK CIRCUITS 436 (RD/LG) AND 437 (YE/LG) FOR A SHORT TO GROUND

- Disconnect: Blend Door Actuator C289 .
- Measure the resistance between ground and the following:
 - HVAC module [C294A](#) Pin 5, circuit 436 (RD/LG).
 - HVAC module [C294A](#) Pin 18, circuit 437 (YE/LG).

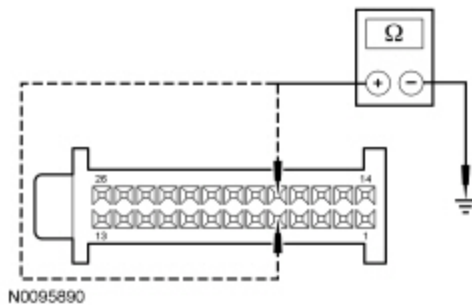

N0095890

Is the resistance greater than 10,000 ohms?

Yes	GO to L4 .
No	REPAIR circuit(s) for a short to ground. TEST the system for normal operation.

L4 CHECK CIRCUITS 438 (RD/WH) AND 437 (YE/LG) FOR A SHORT TO POWER

- Ignition ON.
- Measure the voltage between ground and the following:
 - HVAC module [C294A](#) Pin 15, circuit 438 (RD/WH).
 - HVAC module [C294A](#) Pin 18, circuit 437 (YE/LG).

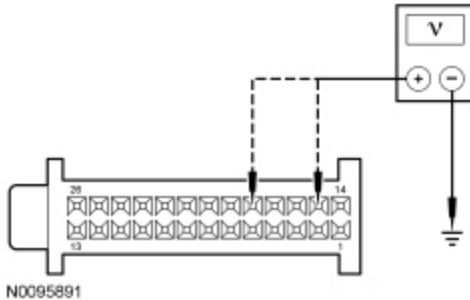

Is any voltage present?

Yes	REPAIR circuit(s) for a short to power. TEST the system for normal operation.
No	GO to L5 .

L5 CHECK THE DOOR ACTUATOR OPERATION

NOTE: If a jumper fuse opens while carrying out this test step, repair the circuit(s) for a short.

- Measure the **low-side** resistance between HVAC module [C294A](#) Pin 15, circuit 438 (RD/WH) and HVAC module [C294A](#) Pin 18, circuit 437 (YE/LG).

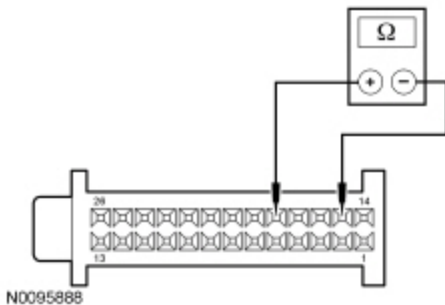

- For no more than 3 seconds, connect a fused jumper wire between:
 - HVAC module [C294A](#) Pin 26, circuit 1566 (RD/YE) and HVAC module [C294A](#) Pin 7, circuit 1376 (BK/LB).
 - HVAC module [C294A](#) Pin 1, circuit 1205 (BK) and HVAC module [C294A](#) Pin 6, circuit 1375 (PK/YE).

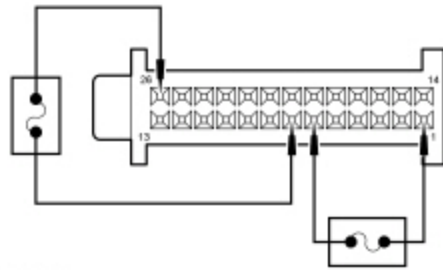

N0095892

- Remove the fused jumpers.
- For no more than 3 seconds, connect a fused jumper wire between:
 - HVAC module [C294A](#) Pin 1, circuit 1205 (BK) and HVAC module [C294A](#) Pin 7, circuit 1376 (BK/LB).
 - HVAC module [C294A](#) Pin 26, circuit 1566 (RD/YE) and HVAC module [C294A](#) Pin 6, circuit 1375 (PK/YE).

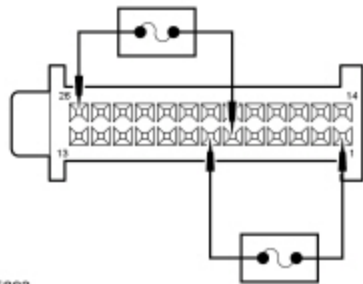

N0095893

Does the resistance smoothly increase and/or decrease when the jumpers are connected?

Yes	INSPECT for broken door and linkage. REPAIR as necessary. If no condition is found, GO to L7 .
No	GO to L6 .

L6 CHECK THE ACTUATOR MOTOR DRIVE CIRCUITS FOR AN OPEN

NOTE: Due to limited connector accessibility, before carrying out this test step, visually inspect the wiring between the HVAC module and actuator for opens or shorts. If no damage is visually evident, proceed with the test.

- Ignition OFF.
- Disconnect: Blend Door Actuator C289 .
- Measure the resistance between HVAC module [C294A](#) Pin 7, circuit 1376 (BK/LB) and blend door actuator [C289](#) Pin 6, circuit 1376 (BK/LB).

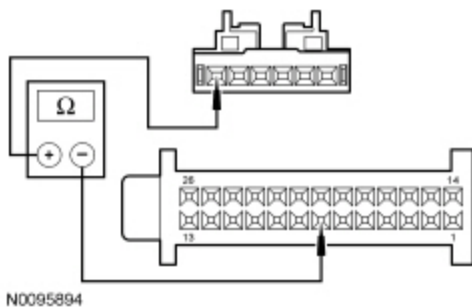

- Measure the resistance between HVAC module [C294A](#) Pin 6, circuit 1375 (PK/YE) and blend door actuator [C289](#) Pin 1, circuit 1375 (PK/YE).

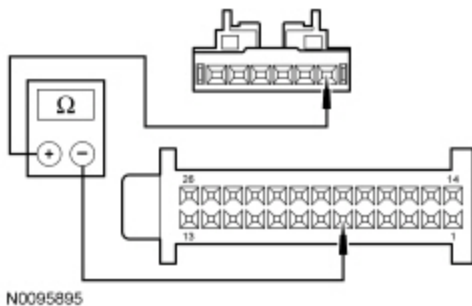

Is the resistance less than 5 ohms?

Yes	INSPECT for binding or broken linkage. REPAIR as necessary. If no condition is found, INSTALL a new door actuator. TEST the system for normal operation.
No	REPAIR the circuit(s) for an open. TEST the system for normal operation.

L7 MODULE ACTUATOR POSITION CALIBRATION

NOTE: The purpose of the module actuator position calibration is to allow the HVAC module to reinitialize and calibrate the actuator stop points. To carry out the calibration, follow the steps below.

- Ignition OFF.
 - Inspect the module connectors for:
 - corrosion.
 - pushed-out terminals.
 - damaged terminals.
 - Connect: EMTC Module C294a .
 - Ignition ON.
 - Select any position except OFF.
 - **NOTE:** The HVAC module will now initialize and calibrate the actuators. Calibration of the actuators will take approximately 30 seconds.
- Operate the system.

Does the concern return?

Yes	INSTALL a new HVAC module. REFER to Section 412-01 . TEST the system for normal operation.
No	The system is now operating correctly. The concern may have been caused by a foreign object in the HVAC case or temporary binding that restricted actuator door travel. CHECK any actuator external linkage. If condition recurs, INSPECT actuator linkage and door for binding and CHECK HVAC case for foreign objects.

Component Tests

Floor/Panel Mode Door Actuator

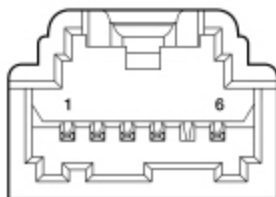

N0086131

Actuator Pins	Approx. Resistance
2 and 3	9,450-11,550 ohms
2 and 4	225-11,275 ohms
3 and 4	225-11,275 ohms
1 and 6	32-40 ohms

Defrost Mode Door Actuator

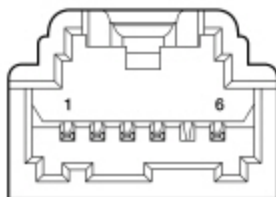

N0086131

Actuator Pins	Approx. Resistance
2 and 3	9,450-11,550 ohms
2 and 4	225-11,275 ohms
3 and 4	225-11,275 ohms
1 and 6	32-40 ohms

Blend Mode Door Actuator

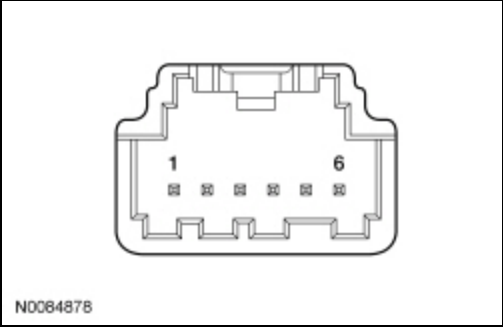

N0064878

Actuator Pins	Approx. Resistance
2 and 3	9,450-11,550 ohms
2 and 4	225-11,275 ohms
3 and 4	225-11,275 ohms
1 and 6	32-40 ohms

Resistor — Blower Motor

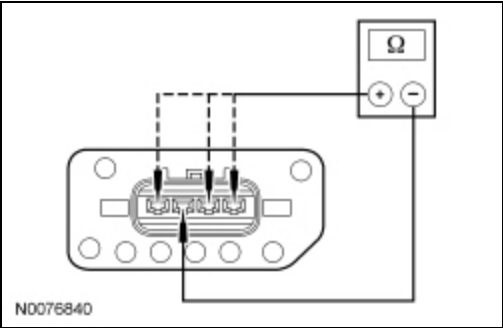

N0076840

Blower Motor Resistor Pins	Resistance
4 and 2	2.0-2.6 ohms
2 and 3	0.2-0.4 ohms
2 and 1	0.8-1.1 ohms

Heater Core

- NOTE:** *If a heater core leak is suspected, the heater core must be tested by carrying out the plugged heater core component test before the heater core pressure test. Carry out a system inspection by checking the heater system thoroughly as follows:*

Inspect for evidence of coolant leakage at the heater water hose to heater core attachments. A coolant leak in the heater water hose could follow the heater core tube to the heater core and appear as a leak in the heater core.

- NOTE:** *Spring-type clamps are installed as original equipment. Installation and overtightening of non-specification clamps can cause leakage at the heater water hose connection and damage the heater core.*

Check the integrity of the heater water hose clamps.

Heater Core — Plugged

- Check to see that the engine coolant is at the correct level.
- Start the engine and turn on the heater.
- When the engine coolant reaches operating temperature, check the heater core inlet and outlet hoses to see if they are hot.

If the inlet hose is not hot:

- the thermostat is not working correctly.

If the outlet hose is not hot:

- the heater core may have an air pocket.
- the heater core may be restricted or plugged.

Heater Core — Pressure Test

Use the Radiator/Heater Core Pressure Tester to carry out the pressure test.

- NOTE:** *Due to space limitations, a bench test may be necessary for pressure testing.*

Clamp off the heater hoses.

- ⚠️ WARNING:** **Before disconnecting any heater water hoses, shut OFF the engine and wait until engine is fully cool. Failure to comply with this warning may result in serious injury or burns from hot liquid escaping from the engine cooling system.**

Disconnect the heater water hoses from the heater core.

3. Install a short piece of heater hose, approximately 101 mm (4 in) long on each heater core tube.
4. Fill the heater core and heater hoses with water and install plug BT-7422-B and the adapter BT-7422-A from the Pressure Test Kit. Secure the heater hoses, plug and adapter with hose clamps.

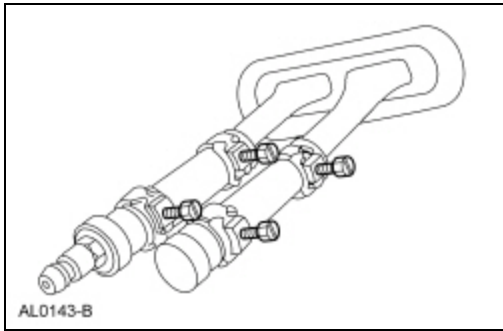

5. Attach the pump and gauge assembly from the Pressure Test Kit to the adapter.
6. Close the bleed valve at the base of the gauge. Pump 138 kPa (20 psi) of air pressure into the heater core.
7. Observe the pressure gauge for a minimum of 3 minutes.
8. If the pressure drops, check the heater water hose connections to the core tubes for leaks. If the heater water hoses do not leak, remove the heater core from the vehicle and carry out the bench test.

Heater Core — Bench Test

1. Remove the heater core from the vehicle. Refer to [Section 412-01](#).
2. Drain all of the coolant from the heater core.
3. Connect the 101 mm (4 in) test heater hoses with plug and adapter to the core tubes. Then connect the Pressure Test Kit to the adapter.
4. Apply 138 kPa (20 psi) of air pressure to the heater core. Submerge the heater core in water.
5. If a leak is observed, install a new heater core.

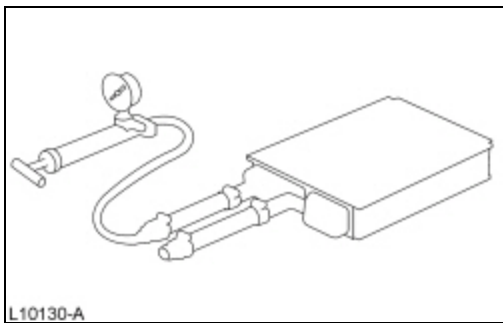

A/C Evaporator/Condenser Core — On Vehicle Leak Test

1. Recover the refrigerant. Refer to [Air Conditioning \(A/C\) System Recovery, Evacuation and Charging](#) in this section.

2. **NOTE:** *DO NOT leak test an A/C evaporator core with the suction accumulator/drier attached to the core tubes.*

Disconnect the suspect A/C evaporator core or A/C condenser core from the A/C system. Refer to [Section 412-01](#).

3. Clean the spring lock couplings. Refer to [Spring Lock Coupling](#) in this section.

4. Connect the appropriate test fittings from the A/C Flush Adapter Kit to the evaporator or condenser tube connections.

5. **NOTE:** *The automatic shut-off valves on some gauge set hoses do not open when connected to the test fittings. If available, use hoses without shut-off valves. If hoses with shut-off valves are used, make sure the valve opens when attached to the test fittings or install an adapter which will activate the valve. The test is not valid if the shut-off valve does not open.*

Connect the red and blue hoses from the R-134a Manifold Gauge Set to the test fittings on the A/C evaporator core or A/C condenser core. Connect the yellow hose to a known good vacuum pump.

6. Open both gauge set valves and start the vacuum pump. Allow the vacuum pump to operate for a minimum of 45 minutes after the gauge set low pressure gauge indicates 101 kPa (30 in-Hg). The 45 minute evacuation is necessary to remove any refrigerant from oil left in the A/C evaporator core or A/C condenser core. If the refrigerant is not completely removed from the oil, outgassing will degrade the vacuum and appear as a refrigerant leak.

7. If the low pressure gauge reading will not drop to 101 kPa (30 in-Hg) when the valves on the gauge and manifold set are open and the vacuum pump is operating, close the gauge set valves and observe the low pressure gauge. If the pressure rises rapidly to zero, a large leak is indicated. Recheck the test fitting connections and gauge set connections before installing a new A/C evaporator core or A/C condenser core.

8. After evacuating for 45 minutes, close the gauge set valves and stop the vacuum pump. Observe the low pressure gauge; it should remain at the 101 kPa (30 in-Hg) mark.

- If the low pressure gauge reading rises 34 or more kPa (10 or more in-Hg) of vacuum from the 101 kPa (30 in-Hg) position in 10 minutes, a leak is indicated.
- If a very small leak is suspected, wait 30 minutes and observe the vacuum gauge.
- If a small amount of vacuum is lost, operate the vacuum pump with gauge valves open for an additional 30 minutes to remove any remaining refrigerant from the oil in the A/C evaporator core or A/C condenser core. Then recheck for loss of vacuum.
- If a very small leak is suspected, allow the system to set overnight with vacuum applied and check for vacuum loss.

9. If the A/C evaporator core or A/C condenser core does leak, as verified by the above procedure, install a new A/C evaporator core or A/C condenser core. Refer to [Section 412-01](#).

A/C Compressor — External Leak Test

1. Install the correct adapter from the A/C Flush Adapter Kit on the rear head of the A/C compressor, using the existing manifold retaining bolt.

2. Connect the high- and low-pressure lines of a manifold gauge set or a refrigerant recovery/recycling station to the corresponding fittings on the adapter.

3. Attach the center hose of the manifold gauge set to a refrigerant container standing in an upright position.

4. Open the low-pressure gauge valve, the high-pressure gauge valve and the valve on the refrigerant container to allow the refrigerant vapor to flow into the A/C compressor.

5. Using the Refrigerant Leak Detector, check for leaks at the compressor shaft.

6. If an external leak is found, install a new A/C compressor. Refer to [Section 412-01](#).

7. When the leak test is complete, recover the refrigerant from the compressor.

