



2009 MY OBD System Operation

Summary for Gasoline Engines

Table of Contents

Introduction – OBD-I, OBD-II and EMD	4
Catalyst Efficiency Monitor	6
Misfire Monitor	11
AIR System Monitor – Flow Check	18
EVAP System Monitor - 0.040" dia. vacuum leak check	21
EVAP System Monitor - 0.020" dia. vacuum leak check	27
EVAP System Monitor - 0.020" dia. Engine Off Natural Vacuum leak check	34
EVAP System Monitor Component Checks	41
Evap Switching Valve (EVAPSV) Diagnostics.....	45
Blocked Purge Line Diagnostics	47
Fuel System Monitor	49
Flex Fuel Operation.....	53
Front HO2S Monitor	55
Front HO2S Signal.....	55
Front HO2S Heaters.....	60
Front UEGO Monitor	62
Front UEGO Signal.....	62
FAOSC (Rear Fuel Trim) Monitor	72
UEGO Heaters	73
Rear HO2S Monitor.....	75
Rear HO2S Signal	75

Rear HO2S Passive Response Test	78
Rear HO2S Decel Fuel Shut Off Response Test.....	81
Rear HO2S Heaters,	87
DPFE EGR System Monitor.....	89
ESM DPFE EGR System Monitor.....	95
Stepper Motor EGR System Monitor – Non-intrusive Monitor	102
PCV System Monitor.....	108
Thermostat Monitor	109
Enhanced Thermostat Monitor.....	110
Cold Start Emission Reduction Component Monitor	112
Cold Start Emission Reduction System Monitor	115
Variable Cam Timing System Monitor	118
Electronic Throttle Control.....	122
Accelerator and Throttle Position Sensor Inputs.....	124
Electronic Throttle Monitor	126
Throttle Plate Position Controller (TPPC) Outputs.....	127
Comprehensive Component Monitor - Engine.....	128
Engine Temperature Sensor Inputs.....	128
IAT Rationality Test.....	129
Fuel Rail Pressure Sensor	129
Throttle Position Sensor.....	129
Mass Air Flow Sensor	129
MAF/TP Rationality Test.....	129
Miscellaneous CPU Tests.....	129
Ignition System Tests.....	129
Engine Outputs.....	129
Intake Manifold Runner Control Systems	129
Intake Manifold Tuning Valve Systems.....	129
Comprehensive Component Monitor - Transmission	129
Transmission Inputs.....	129
Transmission Outputs.....	129
4R75E (RWD) Transmission.....	129
CD4E (FWD) Transmission	129
5R44E (RWD) Transmission.....	129
5R55E (RWD) Transmission.....	129
5R55S (RWD) Transmission.....	129
5R110W (RWD) Transmission.....	129
6R (RWD) Transmission	129
4F27E (FN) (FWD) Transmission	129

ZF 6HP26 (RWD) Transmission	129
Aisin F21 (FWD) Transmission	129
Mazda FNR5 (FWD) Transmission.....	129
6F (FWD) Transmission.....	129
On Board Diagnostic Executive	129
Exponentially Weighted Moving Average	129
I/M Readiness Code.....	129
Catalyst Temperature Model.....	129
Serial Data Link MIL Illumination.....	129
Calculated Load Value	129

Introduction – OBD-I, OBD-II and EMD

OBD-I Systems

OBD-I vehicles use that same PCM, J1850/CAN serial data communication link, J1962 Data Link Connector, and PCM software as the corresponding OBD-II vehicle. The only difference is the possible removal of the rear oxygen sensor(s), fuel tank pressure sensor, canister vent solenoid, and a different PCM calibration. Starting in the 2006 MY, all Federal vehicles from 8,500 to 14,000 lbs. GVWR will have been phased into OBD-II and OBD-I systems will no longer be utilized in vehicles up to 14,000 lbs GVWR.

OBD-II Systems

California OBD-II applies to all California and "California State" gasoline engine vehicles up to 14,000 lbs. Gross Vehicle Weight Rating (GVWR) starting in the 1996 MY and all diesel engine vehicles up to 14,000 lbs. GVWR starting in the 1997 MY.

"California States" are ones that have adopted California emission regulations, starting in the 1998 MY. At this time, Massachusetts, New York, Vermont and Maine have adopted California's regulations. These States receive California-certified vehicles for passenger cars and light trucks, and medium-duty vehicles, up to 14,000 lbs. GVWR."

Federal OBD-II applies to all gasoline engine vehicles up to 8,500 lbs. GVWR starting in the 1996 MY and all diesel engine vehicles up to 8,500 lbs. GVWR starting in the 1997 MY.

Starting in the 2004 MY, Federal vehicle over 8,500 lbs. are required to phase in OBD-II. Starting in 2004 MY, gasoline-fueled Medium Duty Passenger Vehicles (MDPVs) are required to have OBD-II. By the 2006 MY, all Federal vehicles from 8,500 to 14,000 lbs. GVWR will have been phased into OBD-II.

OBD-II system implementation and operation is described in the remainder of this document.

EMD Systems

Engine Manufacturer Diagnostics (EMD) applies to all 2007 MY and beyond California gasoline-fueled and diesel fueled on-road heavy duty engines used in vehicles over 14,000 lbs Gross Vehicle Weight Rating (GVWR). EMD systems are required to functionally monitor the fuel delivery system, exhaust gas recirculation system, particulate matter trap, as well as emission related ECM input inputs for circuit continuity and rationality, and emission-related outputs for circuit continuity and functionality. For gasoline engines, which have no PM trap, EMD requirements are very similar to current OBD-I system requirements. As such, OBD-I system philosophy will be employed, the only change being the addition of some comprehensive component monitor (CCM) rationality and functionality checks.

EMD vehicles use that same PCM, CAN serial data communication link, J1962 Data Link Connector, and PCM software as the corresponding OBD-II vehicle. The only difference is the possible removal of the rear oxygen sensor(s), fuel tank pressure sensor, canister vent solenoid, and a different PCM calibration.

The following list indicates what monitors and functions have been altered from OBD-II for EMD calibrations:

Monitor / Feature	Calibration
Catalyst Monitor	Not required, monitor calibrated out, rear O2 sensors may be deleted.
Misfire Monitor	Calibrated in for service, all DTCs are non-MIL. Catalyst damage misfire criteria calibrated out, emission threshold criteria set to 4%, enabled between 150 °F and 220 °F, 254 sec start-up delay.
Oxygen Sensor Monitor	Rear O2 sensor test calibrated out, rear O2 sensors may be deleted, front O2 sensor response test calibrated out.
EGR Monitor	Same as OBD-II calibration except that P0402 test uses slightly higher threshold.
Fuel System Monitor	Same as OBD-II calibration.
Secondary Air Monitor	Functional (low flow) test calibrated out, circuit codes are same as OBD-II calibration.
Evap System Monitor	Evap system leak check calibrated out, fuel level input circuit checks retained as non-MIL. Fuel tank pressure sensor and canister vent solenoid may be deleted.
PCV Monitor	Same hardware and function as OBD-II.
Thermostat Monitor	Thermostat monitor calibrated out.
Comprehensive Component Monitor	All circuit checks, rationality and functional tests same as OBD-II.
Communication Protocol and DLC	Same as OBD-II, all generic and enhanced scan tool modes work the same as OBD-II but reflect the EMD calibration that contains fewer supported monitors. "OBD Supported" PID indicates EMD (\$11).
MIL Control	Same as OBD-II, it takes 2 driving cycles to illuminate the MIL.

EMD system implementation and operation is a subset of OBD-II and is described in the remainder of this document.

Catalyst Efficiency Monitor

The Catalyst Efficiency Monitor uses an oxygen sensor after the catalyst to infer the hydrocarbon efficiency based on oxygen storage capacity of the ceria and precious metals in the washcoat. Under normal, closed-loop fuel conditions, high efficiency catalysts have significant oxygen storage. This makes the switching frequency of the rear HO₂S very slow and reduces the amplitude of those. As catalyst efficiency deteriorates due to thermal and/or chemical deterioration, its ability to store oxygen declines and the post-catalyst HO₂S signal begins to switch more rapidly with increasing amplitude. The predominant failure mode for high mileage catalysts is chemical deterioration (phosphorus deposition on the front brick of the catalyst), not thermal deterioration.

Index Ratio Method Using a Switching HO₂S Sensor

In order to assess catalyst oxygen storage, the catalyst monitor counts front HO₂S switches during part-throttle, closed-loop fuel conditions after the engine is warmed-up and inferred catalyst temperature is within limits. Front switches are accumulated in up to three different air mass regions or cells. While catalyst monitoring entry conditions are being met, the front and rear HO₂S signal lengths are continually being calculated. When the required number of front switches has accumulated in each cell (air mass region), the total signal length of the rear HO₂S is divided by the total signal length of front HO₂S to compute a catalyst index ratio. An index ratio near 0.0 indicates high oxygen storage capacity, hence high HC efficiency. An index ratio near 1.0 indicates low oxygen storage capacity, hence low HC efficiency. If the actual index ratio exceeds the threshold index ratio, the catalyst is considered failed.

If the catalyst monitor does not complete during a particular driving cycle, the already-accumulated switch/signal-length data is retained in Keep Alive Memory and is used during the next driving cycle to allow the catalyst monitor a better opportunity to complete, even under short or transient driving conditions.

If the catalyst monitor runs to completion during a driving cycle, it will be allowed to run again and collect another set of data during the same driving cycle. This would allow the catalyst monitor to complete up to a maximum of two times per driving cycle, however, the in-use performance ratio numerator for the catalyst monitor will only be allowed to increment once per driving cycle. For example, if the catalyst monitor completes twice during the current driving cycle, the catalyst monitor in-use performance numerator will be incremented once during the current driving cycle and will be incremented again for the second completion on the following driving cycle, after the catalyst monitor entry condition have been met.

Index Ratio Method Using a Wide Range HO₂S Sensor (UEGO)

The switching HO₂S control system compares the HO₂S signals before and after the catalyst to assess catalyst oxygen storage. The front HO₂S signal from UEGO control system is used to control to a target A/F ratio and does not have "switches" As a result, a new method of catalyst monitor is utilized.

The UEGO catalyst monitor is an active/intrusive monitor. The monitor performs a calibratable 10-20 second test during steady state rpm, load and engine air mass operating conditions at normal vehicle speeds. During the test, the fuel control system remains in closed loop, UEGO control with fixed system gains. In order to assess catalyst oxygen storage, the UEGO catalyst monitor is enabled during part-throttle, closed-loop fuel conditions after the engine is warmed-up and inferred catalyst temperature is within limits. While the catalyst monitoring entry conditions are being met, the rear HO₂S signal length is continually being calculated. When the required total calibrated time has been accumulated, the total voltage signal length of the rear HO₂S is divided by a calibrated threshold rear HO₂S signal length to compute a catalyst index ratio. The threshold rear HO₂S signal is calibrated as a function of air mass using a with a catalyst with no precious metal. This catalyst defines the worst case signal length because it has no oxygen storage. If the monitored catalyst has sufficient oxygen storage, little activity is observed on the rear HO₂S voltage signal. An index ratio near 0.0 indicates high oxygen storage capacity, hence high HC/NO_x efficiency. As catalyst oxygen storage degrades, the rear HO₂S voltage signal activity increases. An index ratio near, 1.0 indicates low oxygen storage capacity, hence low HC/NO_x efficiency. If the actual index ratio exceeds the calibrated threshold ratio, the catalyst is considered failed.

General Catalyst Monitor Operation

Rear HO₂S sensors can be located in various ways to monitor different kinds of exhaust systems. In-line engines and many V-engines are monitored by individual bank. A rear HO₂S sensor is used along with the front, fuel-control HO₂S sensor for each bank. Two sensors are used on an in-line engine; four sensors are used on a V-engine. Some V-engines have exhaust banks that combine into a single underbody catalyst. These systems are referred to as Y-pipe systems. They use only one rear HO₂S sensor along with the two front, fuel-control HO₂S sensors. Y-pipe system use three sensors in all. For Y-pipe systems which utilize switching front O₂ sensors, the two front HO₂S sensor signals are combined by the software to infer what the HO₂S signal would have been in front of the monitored catalyst. The inferred front HO₂S signal and the actual single, rear HO₂S signal is then used to calculate the switch ratio.

Most vehicles monitor less than 100% of the catalyst volume – often the first catalyst brick of the catalyst system. Partial volume monitoring is done on LEV and LEV-II vehicles in order to meet the 1.75 * emission-standard threshold for NMHC and NO_x. The rationale for this practice is that the catalysts nearest the engine deteriorate first, allowing the catalyst monitor to be more sensitive and illuminate the MIL properly at lower emission standards.

Many applications that utilize partial-volume monitoring place the rear HO₂S sensor after the first light-off catalyst can or, after the second catalyst can in a three-can per bank system. (A few applications placed the HO₂S in the middle of the catalyst can, between the first and second bricks.)

Index ratios for ethanol (Flex fuel) vehicles vary based on the changing concentration of alcohol in the fuel. The malfunction threshold typically increases as the percent alcohol increases. For example, a malfunction threshold of 0.5 may be used at E10 (10% ethanol) and 0.9 may be used at E85 (85% ethanol). The malfunction thresholds are therefore adjusted based on the % alcohol in the fuel. (Note: Normal gasoline is allowed to contain up to 10% ethanol (E10)).

All vehicles employ an Exponentially Weighted Moving Average (EWMA) algorithm to improve the robustness of the FTP catalyst monitor. During normal customer driving, a malfunction will illuminate the MIL, on average, in 3 to 6 driving cycles. If KAM is reset (battery disconnected), a malfunction will illuminate the MIL in 2 driving cycles. See the section on EWMA for additional information.

Index Ratio Catalyst Monitor

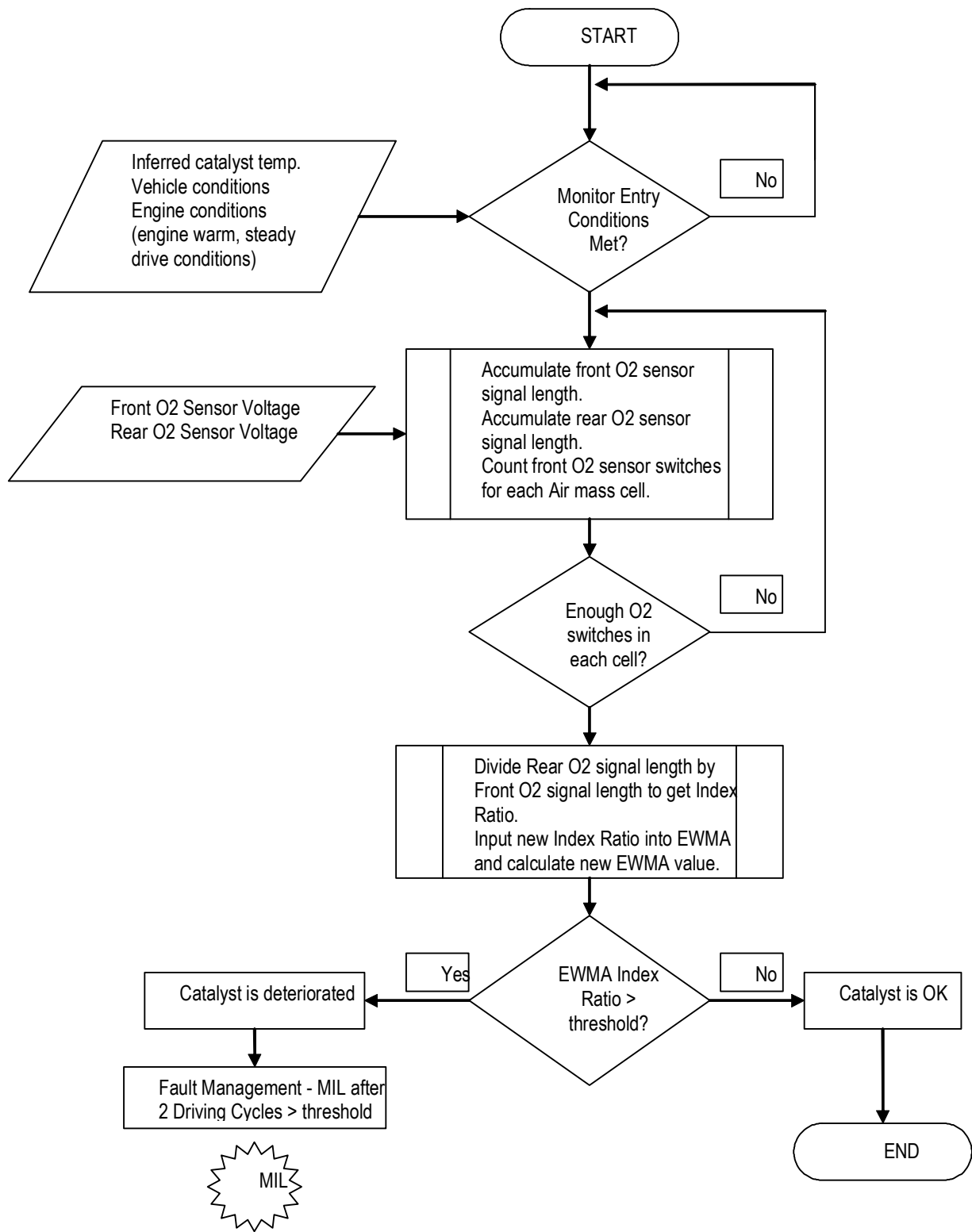

CATALYST MONITOR OPERATION:	
DTCs	P0420 Bank 1 (or Y-pipe), P0430 Bank 2
Monitor execution	once per driving cycle
Monitor Sequence	HO2S response test complete and no DTCs (P0133/P0153) prior to calculating switch ratio, no SAIR pump stuck on DTCs (P0412/P1414), no evap leak check DTCs (P0442/P0456), no EGR stuck open DTCs (P0402)
Sensors OK	ECT, IAT, TP, VSS, CKP
Monitoring Duration	Approximately 700 seconds during appropriate FTP conditions (approximately 100 to 200 oxygen sensor switches are collected) for switching O2 control sensors Approximately 10 to 20 seconds for wide range O2 control sensors.

TYPICAL SWITCHING O2 SENSOR INDEX RATIO CATALYST MONITOR ENTRY CONDITIONS:		
Entry condition	Minimum	Maximum
Time since engine start-up (70 °F start)	330 seconds	
Engine Coolant Temp	170 °F	230 °F
Intake Air Temp	20 °F	180 °F
Time since entering closed loop fuel	30 sec	
Inferred Rear HO2S sensor Temperature	900 °F	
EGR flow (Note: an EGR fault disables EGR)	1%	12%
Throttle Position	Part Throttle	Part Throttle
Rate of Change of Throttle Position		0.2 volts / 0.050 s
Vehicle Speed	5 mph	70 mph
Fuel Level	15%	
First Air Mass Cell	1.0 lb/min	2.0 lb/min
Engine RPM for first air mass cell	1,000 rpm	1,300 rpm
Engine Load for first air mass cell	15%	35%
Monitored catalyst mid-bed temp. (inferred) for first air mass cell	850 °F	1,200 °F
Number of front O2 switches required for first air mass cell	50	
Second Air Mass Cell	2.0 lb/min	3.0 lb/min
Engine RPM for second air mass cell	1,200 rpm	1,500 rpm
Engine Load for second air mass cell	20%	35%
Monitored catalyst mid-bed temp. (inferred) for second air mass cell	900 °F	1,250 °F
Number of front O2 switches required for second air mass cell	70	
Third Air Mass Cell	3.0 lb/min	4.0 lb/min
Engine RPM for third air mass cell	1,300 rpm	1,600 rpm
Engine Load for third air mass cell	20%	40%

Monitored catalyst mid-bed temp. (inferred) for third air mass cell	950 °F	1,300 °F
Number of front O2 switches required for third air mass cell	30	
(Note: Engine rpm and load values for each air mass cell can vary as a function of the power-to-weight ratio of the engine, transmission and axle gearing and tire size.)		

TYPICAL WIDE RANGE O2 SENSOR INDEX RATIO CATALYST MONITOR ENTRY CONDITIONS:		
Entry condition	Minimum	Maximum
Time since engine start-up (70 °F start)	330 seconds	
Engine Coolant Temp	170 °F	230 °F
Intake Air Temp	20 °F	180 °F
Time since entering closed loop fuel	30 sec	
Inferred Rear HO2S sensor Temperature	900 °F	
EGR flow (Note: an EGR fault disables EGR)	1%	12%
Throttle Position	Part Throttle	Part Throttle
Rate of Change of Throttle Position		0.2 volts / 0.050 s
Vehicle Speed	20 mph	80 mph
Fuel Level	15%	
Air Mass	2.0 lb/min	5.0 lb/min
Engine RPM	1,000 rpm	2,000 rpm
Engine Load	20%	60%
Monitored catalyst mid-bed temp. (inferred) for first air mass cell	850 °F	1,200 °F
(Note: Engine rpm, load and air mass values can vary as a function of the power-to-weight ratio of the engine, transmission and axle gearing and tire size.)		

TYPICAL MALFUNCTION THRESHOLDS:
Catalyst monitor index ratio > 0.75 (bank monitor)
Catalyst monitor index-ratio > 0.60 (Y-pipe monitor)
Catalyst monitor index ratio > 0.50 for E10 to > 0.90 for E85 (flex fuel vehicles)

J1979 CATALYST MONITOR MODE \$06 DATA			
Monitor ID	Test ID	Description for CAN	
\$21	\$80	Bank 1 index-ratio and max. limit	unitless
\$22	\$80	Bank 2 index-ratio and max. limit	unitless

** NOTE: In this document, a monitor or sensor is considered OK if there are no DTCs stored for that component or system at the time the monitor is running.

Misfire Monitor

There are two different misfire monitoring technologies used in the 2009 MY. They are Low Data Rate (LDR), and High Data Rate (HDR). The LDR system is capable of meeting the FTP monitoring requirements on most engines and is capable of meeting “full-range” misfire monitoring requirements on 4-cylinder engines. The HDR system is capable of meeting “full-range” misfire monitoring requirements on 6 and 8 cylinder engines. All software allows for detection of any misfires that occur 6 engine revolutions after initially cranking the engine. This meets the OBD-II requirement to identify misfires within 2 engine revolutions after exceeding the warm drive, idle rpm.

Low Data Rate System

The LDR Misfire Monitor uses a low-data-rate crankshaft position signal, (i.e. one position reference signal at 10 deg BTDC for each cylinder event). The PCM calculates crankshaft rotational velocity for each cylinder from this crankshaft position signal. The acceleration for each cylinder can then be calculated using successive velocity values. The changes in overall engine rpm are removed by subtracting the median engine acceleration over a complete engine cycle. The crankshaft acceleration is then processed by two algorithms. The first is optimized for detection of sporadic and single cylinder patterns of misfire; the second is optimized for multi-cylinder patterns. The resulting deviant cylinder acceleration values are used in evaluating misfire in the “General Misfire Algorithm Processing” section below.

High Data Rate System

The High Data Rate (HDR) Misfire Monitor uses a high data rate crankshaft position signal, (i.e. 18 position references per crankshaft revolution). This high-resolution signal is processed using two different algorithms. The first algorithm is optimized to detect “hard” misfires, i.e. one or more continuously misfiring cylinders. The low pass filter filters the high-resolution crankshaft velocity signal to remove some of the crankshaft torsional vibrations that degrade signal to noise. Two low pass filters are used to enhance detection capability – a “base” filter and a more aggressive filter to enhance single-cylinder capability at higher rpm. This significantly improves detection capability for continuous misfires on single cylinders up to redline. The second algorithm, called pattern cancellation, is optimized to detect low rates of misfire. The algorithm learns the normal pattern of cylinder accelerations from the mostly good firing events and is then able to accurately detect deviations from that pattern. Both the hard misfire algorithm and the pattern cancellation algorithm produce a deviant cylinder acceleration value, which is used in evaluating misfire in the “General Misfire Algorithm Processing” section below.

Due to the high data processing requirements, the HDR algorithm may be implemented by the PCM in a separate chip. The chip performs the HDR algorithm calculations and sends the deviant cylinder acceleration values to the PCM microprocessor for additional processing as described below. The chip requires proper operation of the crank and cam sensor inputs. A P1336 will be set if the chip detects noise on the crank sensor input, or if the chip is unable to synchronize with the missing tooth location.. A P1336 points noise present on the crank sensor input or a lack of synchronization between the cam and crank sensors.

Low Data Rate and High Data Rate Systems

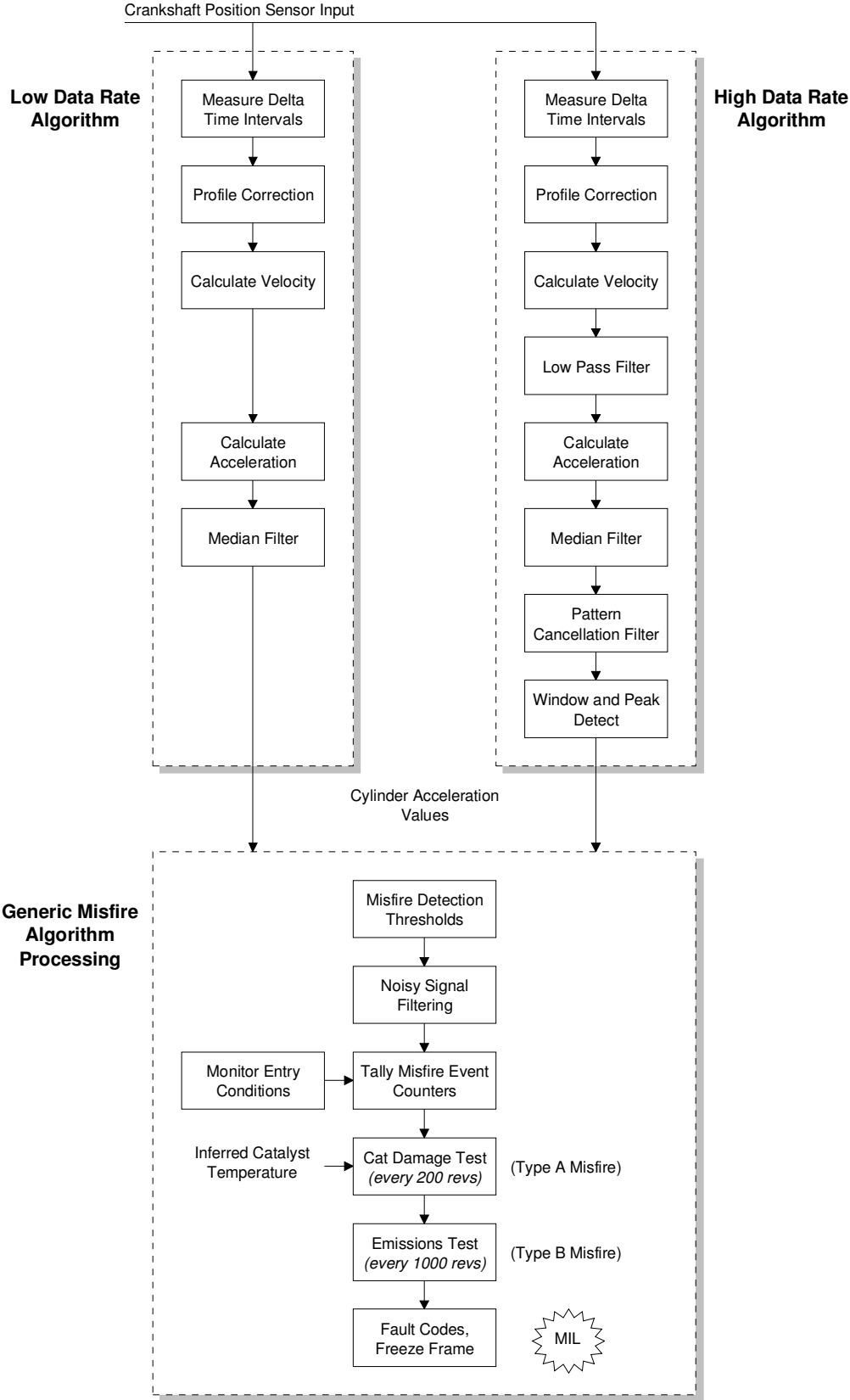

Generic Misfire Algorithm Processing

The acceleration that a piston undergoes during a normal firing event is directly related to the amount of torque that cylinder produces. The calculated piston/cylinder acceleration value(s) are compared to a misfire threshold that is continuously adjusted based on inferred engine torque. Deviant accelerations exceeding the threshold are conditionally labeled as misfires.

The calculated deviant acceleration value(s) are also evaluated for noise. Normally, misfire results in a non-symmetrical loss of cylinder acceleration. Mechanical noise, such as rough roads or high rpm/light load conditions, will produce symmetrical acceleration variations. Cylinder events that indicate excessive deviant accelerations of this type are considered noise. Noise-free deviant acceleration exceeding a given threshold is labeled a misfire.

The number of misfires is counted over a continuous 200 revolution and 1000 revolution period. (The revolution counters are not reset if the misfire monitor is temporarily disabled such as for negative torque mode, etc.) At the end of the evaluation period, the total misfire rate and the misfire rate for each individual cylinder is computed. The misfire rate evaluated every 200 revolution period (Type A) and compared to a threshold value obtained from an engine speed/load table. This misfire threshold is designed to prevent damage to the catalyst due to sustained excessive temperature (1650°F for Pt/Pd/Rh advanced washcoat and 1800°F for Pd-only high tech washcoat). If the misfire threshold is exceeded and the catalyst temperature model calculates a catalyst mid-bed temperature that exceeds the catalyst damage threshold, the MIL blinks at a 1 Hz rate while the misfire is present. If the misfire occurs again on a subsequent driving cycle, the MIL is illuminated.

If a single cylinder is determined to be consistently misfiring in excess of the catalyst damage criteria, the fuel injector to that cylinder will be shut off for 30 seconds to prevent catalyst damage. Up to two cylinders may be disabled at the same time on 6 and 8 cylinder engines and one cylinder is disabled on 4 cylinder engines. This fuel shut-off feature is used on all engines starting in the 2005 MY. After 30 seconds, the injector is re-enabled. If misfire on that cylinder is again detected after 200 revs (about 5 to 10 seconds), the fuel injector will be shut off again and the process will repeat until the misfire is no longer present. Note that ignition coil primary circuit failures (see CCM section) will trigger the same type of fuel injector disablement.

The misfire rate is also evaluated every 1000 rev period and compared to a single (Type B) threshold value to indicate an emission-threshold malfunction, which can be either a single 1000 rev exceedence from startup or four subsequent 1000 rev exceedences on a drive cycle after start-up. Some vehicles will set a P0316 DTC if the Type B malfunction threshold is exceeded during the first 1,000 revs after engine startup. This DTC is normally stored in addition to the normal P03xx DTC that indicates the misfiring cylinder(s). If misfire is detected but cannot be attributed to a specific cylinder, a P0300 is stored. This may occur on some vehicles at higher engine speeds, for example, above 3,500 rpm.

Rough Road Detection

The Misfire Monitor includes a Rough Road Detection (RRD) system to eliminate false misfire indications due to rough road conditions. The RRD system uses data from ABS wheel speed sensors for estimating the severity of rough road conditions. This is a more direct measurement of rough road over other methods which are based on driveline feedback via crankshaft velocity measurements. It improves accuracy over these other methods since it eliminates interactions with actual misfire.

In the event of an RRD system failure, the RRD output will be ignored and the Misfire Monitor will remain active. An RRD system failure could be caused by a failure in any of the input signals to the algorithm. This includes the ABS wheel speed sensors, Brake Pedal sensor, or CAN bus hardware failures. Specific DTCs will indicate the source of these component failures.

A redundant check is also performed on the RRD system to verify it is not stuck high due to other unforeseen causes. If the RRD system indicates rough road during low vehicle speed conditions where it is not expected, the RRD output will be ignored and the Misfire Monitor will remain active.

Profile Correction

"Profile correction" software is used to "learn" and correct for mechanical inaccuracies in the crankshaft position wheel tooth spacing. Since the sum of all the angles between crankshaft teeth must equal 360°, a correction factor can be calculated for each misfire sample interval that makes all the angles between individual teeth equal. . The LDR misfire system will learn one profile correction factor per cylinder (ex. 4 correction factors for a 4 cylinder engine), while the HDR system will learn 36 or 40 correction factors depending on the number of crankshaft wheel teeth (ex. 36 for V6/V8 engines, 40 for V10 engines).

The corrections are calculated from several engine cycles of misfire sample interval data. The "mature" correction factors are the average of a selected number of samples. In order to assure the accuracy of these corrections, a tolerance is placed on the incoming values such that an individual correction factor must be repeatable within the tolerance during learning. This is to reduce the possibility of learning corrections on rough road conditions which could limit misfire detection capability and to help isolate misfire diagnoses from other crankshaft velocity disturbances.

To prevent any fueling or combustion differences from affecting the correction factors, learning is done during decel-fuel cutout. This can be done during closed-throttle, non-braking, de-fueled decelerations in the 60 to 40 mph range after exceeding 60 mph (likely to correspond to a freeway exit condition). In order to minimize the learning time for the correction factors, a more aggressive decel-fuel cutout strategy may be employed when the conditions for learning are present and are typically learned in a single 60 to 40 MPH deceleration, but can be learned during up to 3 such decelerations, or over a higher number of shorter duration decelerations..

For Hybrid Electric Vehicles profile is learned by using the electric drive to spin the crankshaft on the first engine shutdown during which time profile is calculated.

Since inaccuracies in the wheel tooth spacing can produce a false indication of misfire, the misfire monitor is not active until the corrections are learned. In the event of battery disconnection or loss of Keep Alive Memory the correction factors are lost and must be relearned. If the software is unable to learn a profile after three 60 to 40 mph decels, a P0315 DTC is set.

Neutral Profile Correction and Non-Volatile Memory

Neutral profile learning is used at End of Line to learn profile correction via a series of one or more neutral engine rpm throttle snaps. This allows the Misfire Monitor to be activated at the Assembly Plant. A Test Tool command is required to enable this method of learning, so this method will only be performed by a Plant or Service technician. Learning profile correction factors at high-speed (3,000 rpm) neutral conditions versus during 60-40 mph decels optimizes correction factors for higher rpms where they are most needed and eliminates driveline/transmission and road noise effects. This improves signal to noise characteristics which means improved detection capability.

The profile correction factors learned at the Assembly Plant are stored into non-volatile memory. This eliminates the need for specific customer drive cycles. However, misfire profiles may need to be relearned in the Service Bay using a service procedure if major engine work is done or the PCM is replaced. (Re-learning is not required for a reflash.)

The 60-40 mph decel profile learning algorithm has been left active in the software as a backup.

Misfire Monitor Operation:	
DTCs	P0300 to P0310 (general and specific cylinder misfire) P1336 (noisy crank sensor, no cam/crank synchronization) P0315 (unable to learn profile) P0316 (misfire during first 1,000 revs after start-up)
Monitor execution	Continuous, misfire rate calculated every 200 or 1000 revs
Monitor Sequence	None
Sensors OK	CKP, CMP, MAF, ECT/GHT
Monitoring Duration	Entire driving cycle (see disablement conditions below)

Typical misfire monitor entry conditions:		
Entry condition	Minimum	Maximum
Time since engine start-up	0 seconds	0 seconds
Engine Coolant Temperature	20 °F	250 °F
RPM Range (Full-Range Misfire certified, with 2 rev delay)	2 revs after exceeding 150 rpm below "drive" idle rpm	redline on tach or fuel cutoff
Profile correction factors learned in KAM	Yes	
Fuel tank level	15%	

Typical misfire temporary disablement conditions:
Temporary disablement conditions:
Closed throttle decel (negative torque, engine being driven)
Fuel shut-off due to vehicle-speed limiting or engine-rpm limiting mode
High rate of change of torque (heavy throttle tip-in or tip out)
Rough Road conditions present

Typical misfire monitor malfunction thresholds:
Type A (catalyst damaging misfire rate): misfire rate is an rpm/load table ranging from 40% at idle to 4% at high rpm and loads
Type B (emission threshold rate): 1% to 2%

J1979 Misfire Mode \$06 Data

Monitor ID	Test ID	Description for CAN	
A1	\$80	Total engine misfire and catalyst damage misfire rate (updated every 200 revolutions)	percent
A1	\$81	Total engine misfire and emission threshold misfire rate (updated every 1,000 revolutions)	percent
A1	\$82	Highest catalyst-damage misfire and catalyst damage threshold misfire rate (updated when DTC set or clears)	percent
A1	\$83	Highest emission-threshold misfire and emission threshold misfire rate (updated when DTC set or clears)	percent
A1	\$84	Inferred catalyst mid-bed temperature	°C
A2 – AD	\$0B	EWMA misfire counts for last 10 driving cycles	events
A2 – AD	\$0C	Misfire counts for last/current driving cycle	events
A2 – AD	\$80	Cylinder X misfire rate and catalyst damage misfire rate (updated every 200 revolutions)	percent
A2 – AD	\$81	Cylinder X misfire rate and emission threshold misfire rate (updated every 1,000 revolutions)	percent

Profile Correction Operation	
DTCs	P0315 - unable to learn profile in three 60 to 40 mph decels
Monitor Execution	Once per profile learning sequence.
Monitor Sequence:	Profile must be learned before misfire monitor is active.
Sensors OK:	CKP, CMP, CKP/CMP in synch
Monitoring Duration;	10 cumulative seconds in conditions (a maximum of three 60-40 mph defueled decels)

Typical profile learning entry conditions (Customer drive cycle):		
Entry condition	Minimum	Maximum
Engine in decel-fuel cutout mode for 4 engine cycles		
Brakes applied (Brake On/Off Switch)	No	No
Engine RPM	1300 rpm	3700 rpm
Change in RPM		600 rpm/background loop
Vehicle Speed	30 mph	75 mph
Learning tolerance		1%

Typical profile learning entry conditions (Assembly Plant or Service Bay):		
Entry condition	Minimum	Maximum
Engine in decel-fuel cutout mode for 4 engine cycles		
Park/Neutral gear		
Engine RPM	2000 rpm	3000 rpm
Learning tolerance		1%

AIR System Monitor – Flow Check

Secondary air systems typically utilize an electric air pump as well as one or two electrically controlled check valves to deliver air into the exhaust manifold. For the 2006 MY, LEV-II vehicles are required to check for a decrease in secondary air flow that would cause emissions to exceed 1.5 * std. In addition, the secondary air flow system must be monitored during normal operation. Previously, a functional check was done on a hot, stabilized idle.

The only vehicle which uses secondary air in the 2009 MY is the 2.3L PZEV Fusion. It uses a system with ported air. This means that airflow is delivered to each individual exhaust port. The secondary air pump is energized soon after start-up while the fuel system is in open loop. After the O₂ sensors warm up, the secondary air pump may continue to be energized while the fuel system goes into closed loop fuel. The secondary air system may continue to run in closed loop fuel until the air pump is de-energized. The typical time period during which the AIR pump is energized is approximately 5 to 12 seconds.

In order to meet the 2006 MY monitoring requirements, the air pump inlet hose was routed so as to draw in airflow that has been metered by the Mass Air Flow (MAF) sensor. When the air pump is energized, the MAF sensor will show a corresponding increase in air flow. The AIR pump flow check monitors the MAF sensor signal and two air flow models during normal secondary air system operation to determine if secondary air is being delivered into the exhaust system. The air pump flow test compares the actual change in MAF during the pump on and off transitions to the expected change in air flow from the secondary air flow model. (A throttle body flow model is used to "zero out" errors in the air meter and to compensate for off idle driving conditions.) The actual air flow is divided by the expected air flow to calculate an "On flow ratio" and an "Off flow ratio". A flow ratio that is much less than 1.0 means that the air pump has no/low flow, or the inlet hose to the pump is disconnected. If secondary air system operation extends into closed loop fuel, fuel trim feedback is used to discriminate between low pump flow and inlet hose disconnection. A low flow ratio with a lean fuel system indicates a disconnected inlet hose. A flow ratio much higher than 1.0 (and a rich fuel system indication) means that the outlet hose from the pump is disconnected.

The flow test can set the following three codes: P0491 – Low Pump Flow, P0410 - Pump Inlet Hose Off, or P2448 - Pump Outlet Hose Off. If the flow ratio is low, the monitor will either set a P0491 or a P0410 if enough closed loop fuel operation has occurred. If there was insufficient closed loop fuel operation, the monitor will set both a P0491 and a P0410. If the flow ratio is too high, a P2448 code will be set for outlet hose off.

The electric air pump draws high current and must be energized through a separate relay. Both the primary and secondary circuits are checked for opens and shorts. First, the output driver within the PCM (primary circuit) is checked for circuit continuity (P0412). This circuit energizes the relay and the vacuum-operated check and control valve(s). Next, a feedback circuit from the secondary side of the relay to the PCM is used to check secondary circuit continuity (P2257, P2258).

PZEV Port Oxidation Secondary Air System

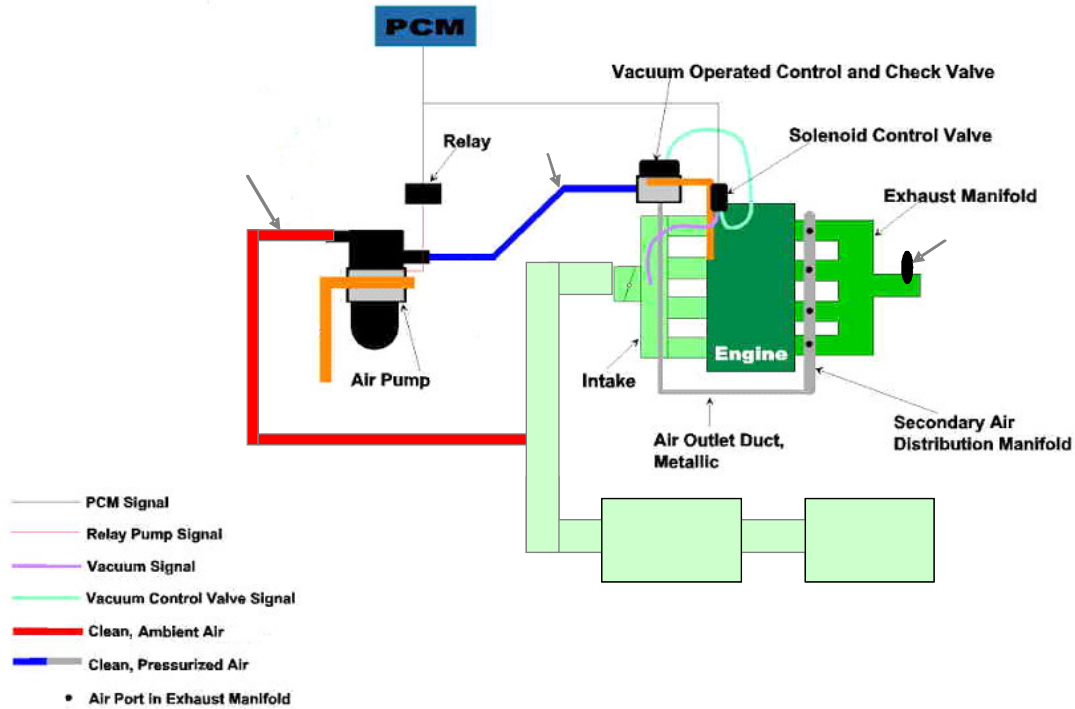

AIR Monitor Flow Check Operation:

DTCs	P0491 Pump Low Flow P0410 Pump Inlet Hose Off P2448 Pump Outlet Hose Off P0412 primary side circuit check P2257, P2258 secondary side circuit checks
Monitor execution	Flow check - once per driving cycle, circuit checks - continuous
Monitor Sequence	Runs approx. 5 seconds after start during normal SAIR operation
Sensors OK	ECT, IAT, MAF, TP, ETC, and HO2S
Monitoring Duration	From 5 to 12 seconds

Typical AIR flow check entry conditions: (The monitor will run when the air pump runs, the entry conditions below are secondary air system entry conditions.)

Entry condition	Minimum	Maximum
Time since engine start-up	5 seconds	13 seconds
Engine Coolant Temperature	40 °F	150 °F
Predicted Pump Flow	0.2 lbm/min	
Manifold Vacuum	7 in Hg	
Catalyst Temperature		1200 deg F
Battery Voltage	11 volts	

Note: There is a Throttle position stability check that can delay the calculation of the flow ratio. If the throttle is continuously moving, it is possible, to delay calculation of the flow ratio.

Typical AIR functional check malfunction thresholds:

On and Off Flow ratio < 0.4 (P0491 - Low Flow or, P0410 - Inlet Hose Off)

On Flow ratio > 1.6 (P2448 – Outlet Hose Off)

J1979 Secondary Air Mode \$06 Data

Mon ID	Comp ID	Description for CAN	Units
\$72	\$80	HO2S11 voltage for upstream flow test and rich limit	volts
\$72	\$81	HO2S lean timer test	
\$72	\$82	On Flow Ratio and limits	unitless
\$72	\$83	Off Flow Ratio and limits	unitless
\$72	\$84	Flow Ratio AF indicator and limits PETA_AF_SHIFT	unitless
\$72	\$85	Timer to indicate if a valid AF shift can be calculated PETA_CL_TMR	seconds

I/M Readiness Indication

If the ambient air temperature (IAT) is less than 40 °F, or the altitude is greater than 8,000 feet (BARO < 22.5 "Hg), the Secondary Air system will not be enabled, therefore, the Secondary Air monitor cannot complete. If all the conditions to run the Secondary Air Monitor are correct except for IAT and BARO, a timer starts to accumulate the time in these conditions. If the timer reaches the maximum value for Secondary Air enablement (approximately 13 seconds), the Secondary Air Monitor I/M Readiness bit will be set to a "ready" condition after two such driving cycles.

EVAP System Monitor - 0.040" dia. vacuum leak check

Vehicles that meet enhanced evaporative requirements utilize a vacuum-based evaporative system integrity check. The evap system integrity check uses a Fuel Tank Pressure Transducer (FTPT), a Canister Vent Solenoid (CVS) and Fuel Level Input (FLI) along with a Canister Purge Valve (CPV) to find 0.040" diameter or larger evap system leaks. Federal vehicles can utilize a 0.040" leak check rather than the 0.020" leak check required for California vehicles. Additionally, some programs may elect to run a 0.090" / 0.020" detection configuration and turn the 0.040" leak test off as provided for in the regulations. In the case of heavy duty gasoline engines (> 14,000 lbs), the regulations require 0.150" leak detection only

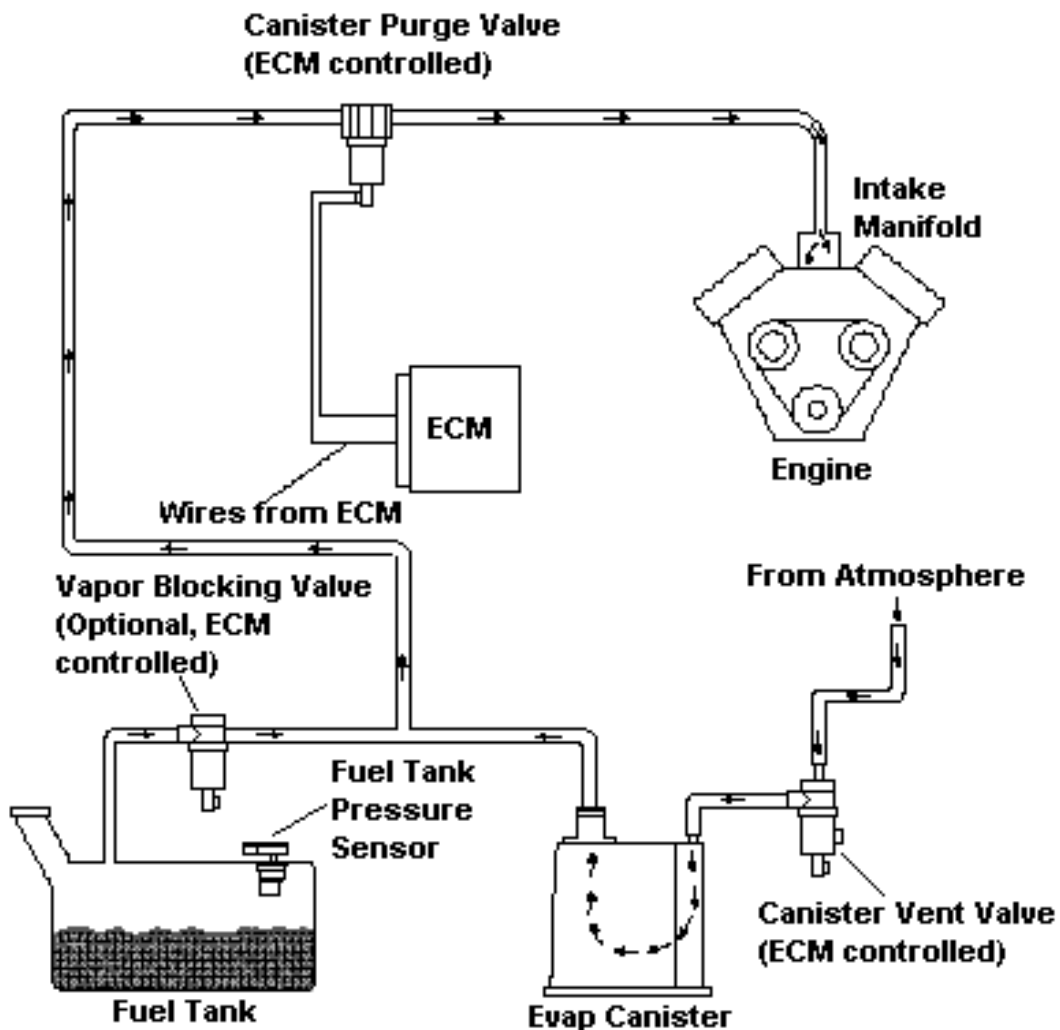

The evap system integrity test is done under conditions that minimize vapor generation and fuel tank pressure changes due to fuel slosh since these could result in false MIL illumination. The check is run after a 6 hour cold engine soak (engine-off timer), during steady highway speeds at ambient air temperatures (inferred by IAT) between 40 and 100 °F.

A check for refueling events is done at engine start. A refuel flag is set in KAM if the fuel level at start-up is at least 20% of total tank capacity greater than fuel fill at engine-off. It stays set until the evap monitor completes Phase 0 of the test as described below. Note that on some vehicles, a refueling check may also be done continuously, with the engine running to detect refueling events that occur when the driver does not turn off the vehicle while refueling (in-flight refueling).

The evap system integrity test is done in four phases.

(Phase 0 - initial vacuum pulldown):

First, the Canister Vent Solenoid is closed to seal the entire evap system, and then the Canister Purge Valve (CPV) is opened to pull an 8" H₂O vacuum. If the initial vacuum could not be achieved, a large system leak is indicated (P0455). This could be caused by a fuel cap that was not installed properly, a stuck open Capless Fuel Fill valve, a large hole, an overfilled fuel tank, disconnected/kinked vapor lines, a Canister Vent Solenoid that is stuck open, a CPV that is stuck closed, or a disconnected/blocked vapor line between the CPV and the FTPT.

Note: 2009 Model Year and beyond implementations require 2 or 3 gross leak failures in-a-row prior to setting a P0455 DTC.

If the initial vacuum could not be achieved after a refueling event, a gross leak, fuel cap off (P0457) is indicated and the recorded minimum fuel tank pressure during pulldown is stored in KAM. A "Check Fuel Cap" light may also be illuminated. On vehicles with capless fuel fill, a message instructing the customer to check the Capless Fuel Fill valve will appear in conjunction with a P0457 DTC. Depending on calibration, the MIL may be illuminated in two or three trips with a P0457 failure.

If the initial vacuum is excessive, a vacuum malfunction is indicated (P1450). This could be caused by kinked vapor lines or a stuck open CPV. If a P0455, P0457, or P1450 code is generated, the evap test does not continue with subsequent phases of the small leak check, phases 1-4.

Note: Not all vehicles will have the P0457 test or the Check Fuel Cap light implemented. These vehicles will continue to generate only a P0455. After the customer properly secures the fuel cap, the P0457, Check Fuel Cap and/or MIL will be cleared as soon as normal purging vacuum exceeds the P0457 vacuum level stored in KAM.

Phase 1 - Vacuum stabilization

If the target vacuum is achieved, the CPV is closed and vacuum is allowed to stabilize for a fixed time. If the pressure in the tank immediately rises, the stabilization time is bypassed and Phase 2 of the test is entered.

Some software has incorporated a "leaking" CPV test, which will also set a P1450 (excessive vacuum) DTC. This test is intended to identify a CPV that does not seal properly, but is not fully stuck open. If more than 1 " H₂O of additional vacuum is developed in Phase 1, the evap monitor will bypass Phase 2 and go directly to Phase 3 and open the canister vent solenoid to release the vacuum. Then, it will proceed to Phase 4, close the canister vent solenoid and measure the vacuum that develops. If the vacuum exceeds approximately 4 " H₂O, a P1450 DTC will be set.

Phase 2 - Vacuum hold and decay

Next, the vacuum is held for a calibrated time and the vacuum level is again recorded at the end of this time period. The starting and ending vacuum levels are checked to determine if the change in vacuum exceeds the vacuum bleed up criteria. Fuel Level Input and ambient air temperature are used to adjust the vacuum bleed-up criteria for the appropriate fuel tank vapor volume. Steady state conditions must be maintained throughout this bleed up portion of the test. The monitor will abort if there is an excessive change in load, fuel tank pressure or fuel level input since these are all indicators of impending or actual fuel slosh. If the monitor aborts, it will attempt to run again (up to 20 or more times). If the vacuum bleed-up criteria is not exceeded, the small leak test is considered a pass. If the vacuum bleed-up criteria is exceeded on three successive monitoring events, a 0.040 “ dia. leak is likely and a final vapor generation check is done to verify the leak, phases 3-4. Excessive vapor generation can cause a false MIL.

Phase 3 - Vacuum release

This stage of the vapor generation check is done by opening the CVS and releasing any vacuum. The system will remain vented to atmosphere for approximately 30 - 60 seconds and then proceed to phase 4.

Phase 4 - Vapor generation

This stage of the vapor generation check is done by closing the CVS and monitoring the pressure rise in the evaporative system. If the pressure rise due to vapor generation is below the threshold limit for absolute pressure and change in pressure, a P0442 DTC is stored.

0.040" Evaporative System Monitor

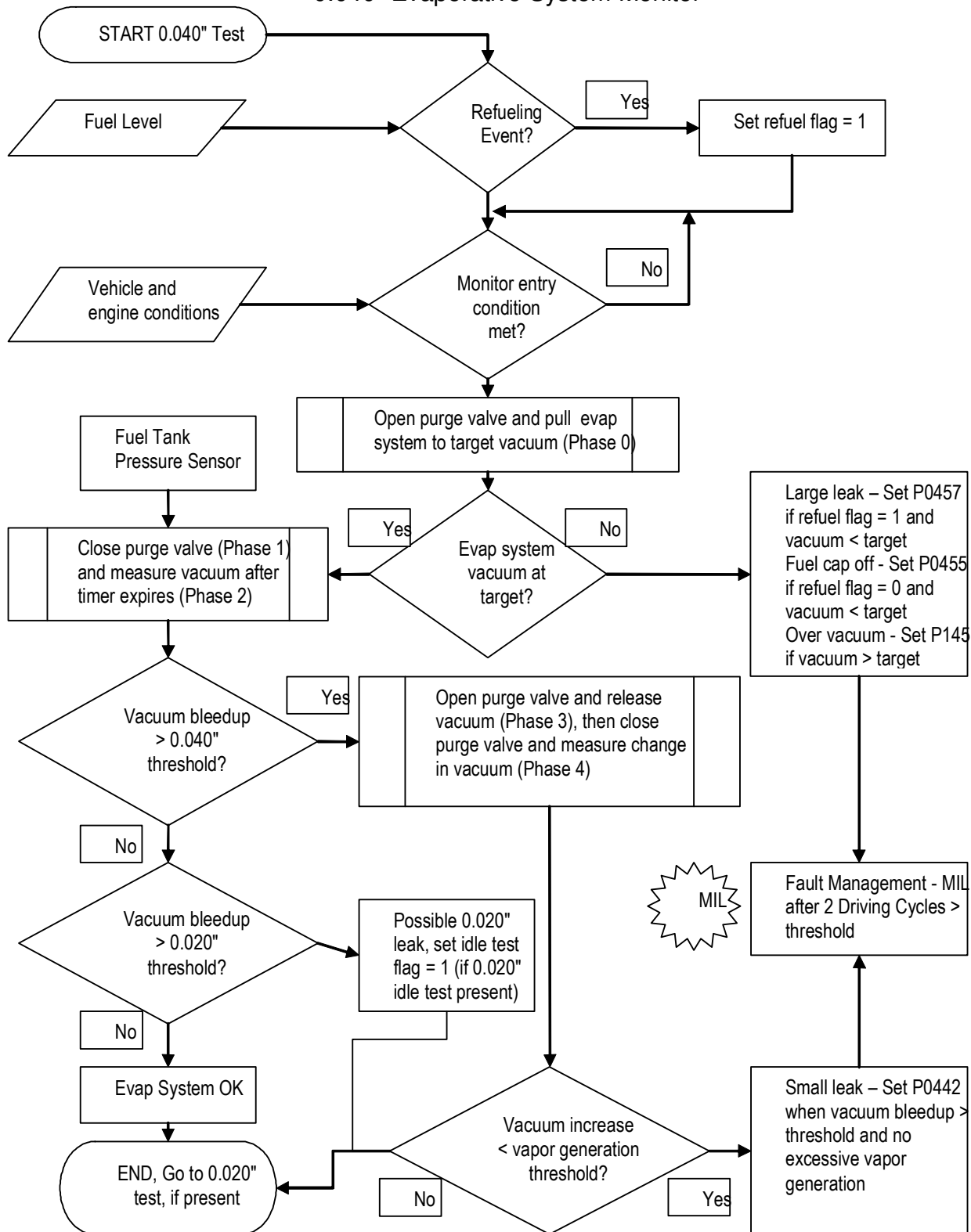

0.040" EVAP Monitor Operation:	
DTCs	P0455 (gross leak), P1450 (excessive vacuum), P0457 (gross leak, cap off), P0442 (0.040" leak)
Monitor execution	once per driving cycle
Monitor Sequence	HO2S monitor completed and OK
Sensors/Components OK	MAF, IAT, VSS, ECT, CKP, TP, FTP, CPV, CVS
Monitoring Duration	360 seconds (see disablement conditions below)

Typical 0.040" EVAP monitor entry conditions, Phases 0 through 4:		
Entry condition	Minimum	Maximum
Engine off (soak) time	6 hours	
Time since engine start-up	330 seconds	1800 to 2700 seconds
Intake Air Temp	40 °F	95 - 100 °F
BARO (<8,000 ft altitude)	22.0 " Hg	
Engine Load	20%	70%
Vehicle Speed	40 mph	90 mph
Purge Duty Cycle	75%	100%
Purge Flow	0.05 lbm/min	0.10 lbm/min
Fuel Fill Level	15%	85%
Fuel Tank Pressure Range	- 17 H ₂ O	1.5 H ₂ O

Typical 0.040" EVAP abort (fuel slosh) conditions for Phase 2:
Change in load: > 20%
Change in tank pressure: > 1 " H ₂ O
Change in fuel fill level: > 15%
Number of aborts: > 255

Typical 0.040 EVAP monitor malfunction thresholds:
P1450 (Excessive vacuum): < -8.0 in H ₂ O over a 30 second evaluation time or > -4. in H ₂ O vapor generation
P0455 (Gross leak): > -8.0 in H ₂ O over a 30 second evaluation time.
P0457 (Gross leak, cap off): > -8.0 in H ₂ O over a 30 second evaluation time after a refueling event.
P0442 (0.040" leak): > 2.5 in H ₂ O bleed-up over a 15 second evaluation time at 75% fuel fill. (Note: bleed-up and evaluation times vary as a function of fuel fill level and ambient air temperature)
P0442 vapor generation limit: < 2.5 in H ₂ O over a 120 second evaluation time

J1979 Evaporative System Mode \$06 Data

Test ID	Comp ID	Description	Units
\$3A	\$80	Phase 0 end pressure result and test limits (data for P1450 – excessive vacuum)	Pa
\$3A	\$81	Phase 4 vapor generation minimum change in pressure and test limits (data for P1450, CPV stuck open)	Pa
\$3A	\$82	Phase 0 end pressure result and test limits (data for P0455/P0457 – gross leak/cap off)	Pa
\$3B	\$80	Phase 2 0.040" cruise leak check vacuum bleed-up and test limits (data for P0442 – 0.040" leak)	Pa

Note: Default values (0.0 Pa) will be displayed for all the above TIDs if the evap monitor has never completed. Each TID is associated with a particular DTC. The TID for the appropriate DTC will be updated based on the current or last driving cycle, default values will be displayed for any phases that have not completed.

EVAP System Monitor - 0.020" dia. vacuum leak check

Some vehicles that meet enhanced evaporative requirements utilize a vacuum-based evaporative system integrity check that checks for 0.020" dia leaks. The evap system integrity check uses a Fuel Tank Pressure Transducer (FTPT), a Canister Vent Solenoid (CVS) and Fuel Level Input (FLI) along with the Canister Purge Valve (CPV) to find 0.020" diameter, 0.040" diameter, or larger evap system leaks.

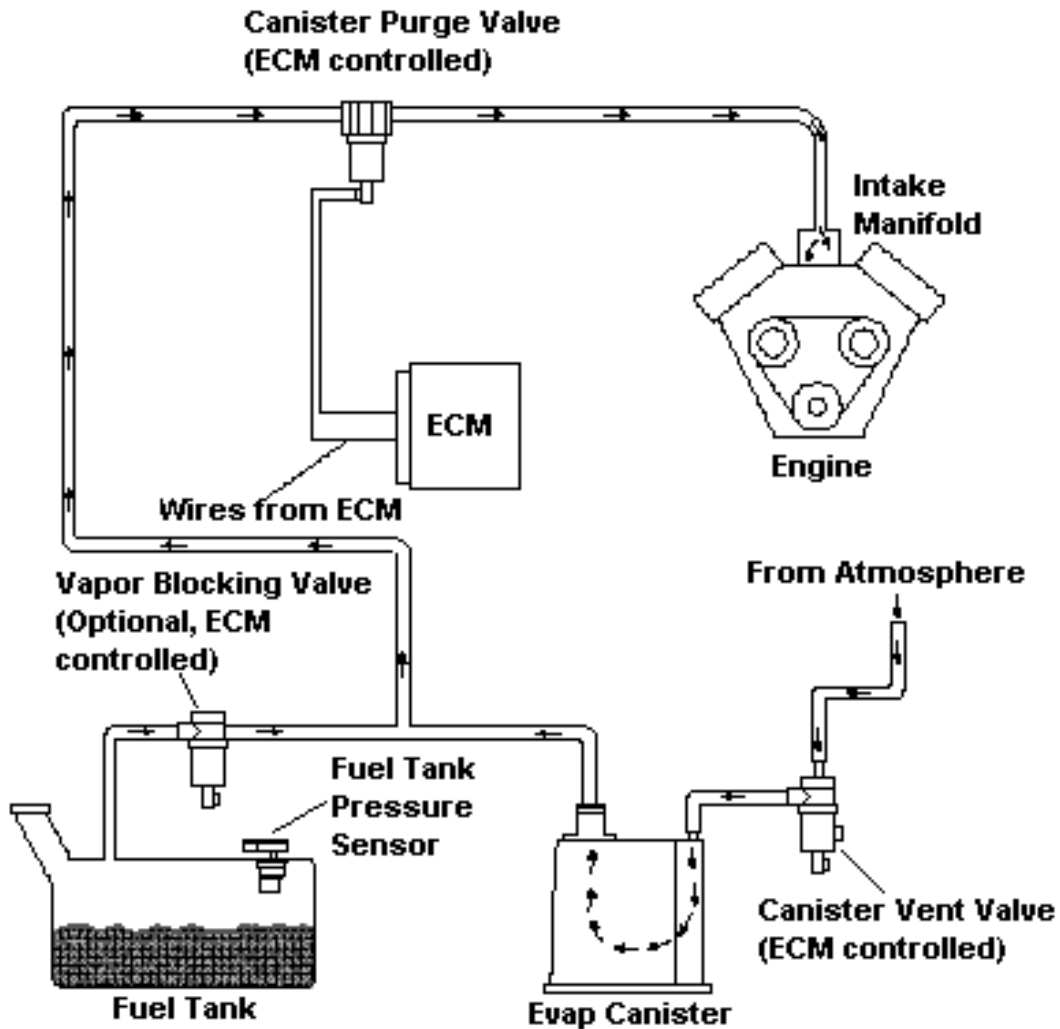

The evap system integrity test is done under two different sets of conditions - first a cruise test is performed to detect 0.040" dia leaks and screen for 0.020" leaks. If a 0.020" dia leak is suspected during the cruise test, an idle test is performed to verify the leak under more restrictive, but reliable, cold-start-idle conditions.

The cruise test is done under conditions that minimize vapor generation and fuel tank pressure changes due to fuel slosh since these could result in false MIL illumination. The check is run after a 6 hour cold engine soak (engine-off timer), during steady highway speeds at ambient air temperatures (inferred by IAT) between 40 and 100 °F.

A check for refueling events is done at engine start. A refuel flag is set in KAM if the fuel level at start-up is at least 20% of total tank capacity greater than fuel fill at engine-off. It stays set until the evap monitor completes Phase 0 of the test as described below. The refueling flag is used to prohibit the 0.020" idle test until the gross leak check is done during cruise conditions. This is done to prevent potential idle concerns resulting from the high fuel vapor concentrations present with a fuel cap off/gross leak condition. Note that on some vehicles, a refueling check may also be done continuously, with the engine running to detect refueling events that occur when the driver does not turn off the vehicle while refueling (in-flight refueling).

The cruise test is done in four phases.

Phase 0 - initial vacuum pulldown

First, the Canister Vent Solenoid is closed to seal the entire evap system, and then the CPV is opened to pull an 8" H₂O vacuum.

If the initial vacuum could not be achieved, a large system leak is indicated (P0455). This could be caused by a fuel cap that was not installed properly, a large hole, an overfilled fuel tank, disconnected/kinked vapor lines, a Canister Vent Solenoid that is stuck open, a CPV that is stuck closed, or a disconnected/blocked vapor line between the CPV and the FTPT.

If the initial vacuum could not be achieved after a refueling event, a gross leak, fuel cap off (P0457) is indicated and the recorded minimum fuel tank pressure during pulldown is stored in KAM. A "Check Fuel Cap" light may also be illuminated.

If the initial vacuum is excessive, a vacuum malfunction is indicated (P1450). This could be caused by blocked vapor lines between the FTPT and the Canister Vent Solenoid, or a stuck open CPV. If a P0455, P0457, P1443, or P1450 code is generated, the evap test does not continue with subsequent phases of the small leak check, phases 1-4. These codes also prevent the idle portion of the 0.020" dia leak check from executing.

Note: Not all vehicles will have the P0457 test or the Check Fuel Cap light implemented. These vehicles will continue to generate only a P0455. After the customer properly secures the fuel cap, the P0457, Check Fuel Cap and/or MIL will be cleared as soon as normal purging vacuum exceeds the P0457 vacuum level stored in KAM.

Phase 1 - Vacuum stabilization

If the target vacuum is achieved, the CPV is closed and vacuum is allowed to stabilize for a fixed time. If the pressure in the tank immediately rises, the stabilization time is bypassed and Phase 2 of the test is entered.

Some software has incorporated a "leaking" CPV test, which will also set a P1450 (excessive vacuum) DTC. This test is intended to identify a CPV that does not seal properly, but is not fully stuck open. If more than 1 " H₂O of additional vacuum is developed in Phase 1, the evap monitor will bypass Phase 2 and go directly to Phase 3 and open the canister vent solenoid to release the vacuum. Then, it will proceed to Phase 4, close the canister vent solenoid and measure the vacuum that develops. If the vacuum exceeds approximately 4 " H₂O, a P1450 DTC will be set.

Phase 2 - Vacuum hold and decay

Next, the vacuum is held for a calibrated time. Two test times are calculated based on the Fuel Level Input and ambient air temperature. The first (shorter) time is used to detect 0.040" dia leaks; the second (longer) time is used to detect 0.020" dia leaks. The initial vacuum is recorded upon entering Phase 2. At the end of the 0.040" dia test time, the vacuum level is recorded. The starting and ending vacuum levels are checked to determine if the change in vacuum exceeds the 0.040" dia vacuum bleed up criteria. If the 0.040" dia vacuum bleed-up criteria is exceeded on three successive monitoring attempts, a 0.040" dia leak is likely and a final vapor generation check is done to verify the leak (phases 3 and 4).

If the 0.040" dia bleed-up criteria is not exceeded, the test is allowed to continue until the 0.020" dia leak test time expires. The starting and ending vacuum levels are checked to determine if the change in vacuum exceed the 0.020" dia vacuum bleed-up criteria. If the 0.020" dia vacuum bleed-up is exceed on a single monitoring attempt, a 0.020" dia leak is likely and a final vapor generation check is done to verify the leak (phases 3 and 4).

If the vacuum bleed-up criteria is not exceeded, the leak test (either 0.040" or 0.020" dia is considered a pass. For both the 0.040" and 0.020" dia leak check, Fuel Level Input and Intake Air Temperature is used to adjust the vacuum bleed-up criteria for the appropriate fuel tank vapor volume and temperature. Steady state conditions must be maintained throughout this bleed up portion of the test. The monitor will abort if there is an excessive change in load, fuel tank pressure or fuel level input since these are all indicators of impending or actual fuel slosh. If the monitor aborts, it will attempt to run again (up to 20 or more times) until the maximum time-after-start is reached.

Phase 3 - Vacuum release

The vapor generation check is initiated by opening the Canister Vent Solenoid for a fixed period of time and releasing any vacuum. The CPV remains closed.

Phase 4 - Vapor generation

In this phase, the sealed system is monitored to determine if tank pressure remains low or if it is rising due to excessive vapor generation. The initial tank pressure is recorded. The pressure is monitored for a change from the initial pressure, and for absolute pressure. If the pressure rise due to vapor generation is below the threshold limit for absolute pressure and for the change in pressure, and a 0.040" dia leak was indicated in phase 2, a P0442 DTC is stored. If the pressure rise due to vapor generation is below the threshold limit for absolute pressure and for the change in pressure, and a 0.020" dia leak was indicated in phase 2, a 0.020" idle check flag is set to run the 0.020" leak check during idle conditions.

Idle Check

The long test times required to detect a 0.020" dia leak in combination with typical road grades can lead to false 0.020" leak indications while the vehicle is in motion. The Idle Check repeats Phases 0, 1, and 2 with the vehicle stationary to screen out leak indications caused by changes in altitude. The 0.020" idle check is done under cold-start conditions to ensure that the fuel is cool and cannot pick up much heat from the engine, fuel rail, or fuel pump. This minimizes vapor generation. The 0.020" idle check is, therefore, conducted only during the first 10 minutes after engine start.

The 0.020" dia leak test entry conditions, test times and thresholds are used. Unique criteria for excessive changes in load, fuel tank pressure and fuel level are used to indicate fuel slosh. The test is aborted if vehicle speed exceeds a calibrated threshold, approx. 10 mph. The initial vacuum pull-down (phase 0) can start with the vehicle in motion in order to minimize the required time at idle to complete the test. If the vacuum bleed-up is greater than the 0.020" dia max. criteria during a single monitoring event, a P0456 DTC is stored. If the vacuum bleed-up is less than the 0.020" dia min. criteria, the pending P0456 DTC may be cleared. If the vacuum bleed-up is in between, no leak assessment is made. A flowchart of the entire 0.020" test sequence is provided below, on a subsequent page.

Ford's 0.020" evaporative system monitor is designed to run during extended, cold-start idle conditions where the fuel is cool and not likely to generate excessive vapors. These conditions will typically occur at traffic lights or immediately after start-up, (e.g. idle in the driveway).

As indicated previously, the 0.020" idle test uses two sets of malfunction thresholds to screen out test results in the area where "leak" and "no-leak" distributions overlap. Loss of vacuum greater than the 0.020" malfunction criteria is designated as a failure. No/low vacuum loss below the pass criteria is designated a pass. Vacuum loss that is greater than the pass criteria but less than the failure criteria is indeterminate and does not count as a pass or a fail.

Test results in this overlap area can stem from high volatility fuel at high ambient temperatures. These situations are not expected to be encountered routinely by customers. Therefore, this strategy will only temporarily hamper monitor performance, while effectively preventing false MIL illumination.

A more detailed description of the functional characteristics of the Evaporative Monitor is provided in the representative calibration submissions to the agency. Additional calibration information is contained on file by Ford Motor Company and may be obtained via agency request.

0.020" Evaporative System Monitor

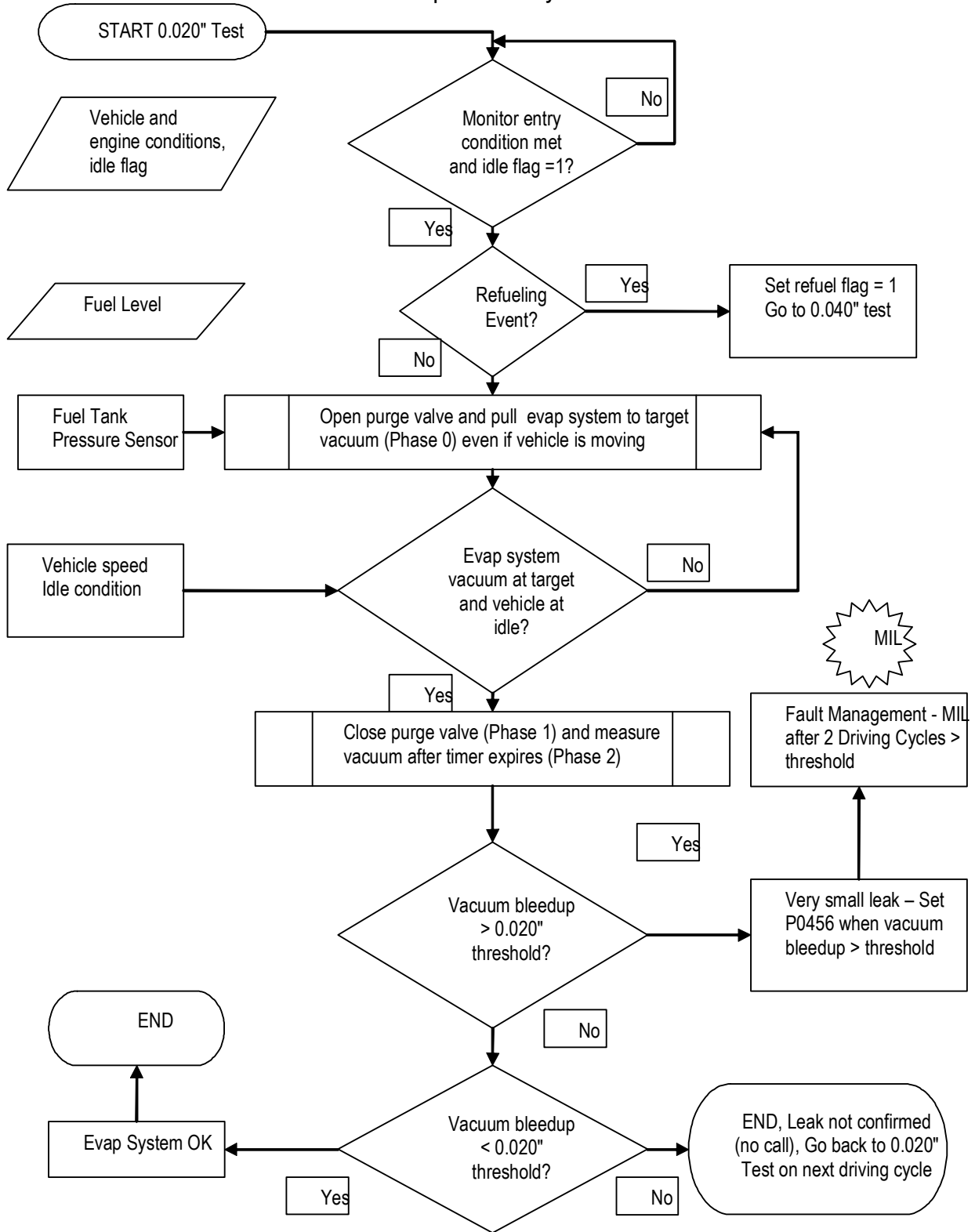

0.020" EVAP Monitor Operation:	
DTCs	P0455 (gross leak), P1450, (excessive vacuum), P0457 (gross leak, cap off), P0442 (0.040" leak), P0456 (0.020" leak)
Monitor execution	once per driving cycle for 0.040" dia leak once per driving cycle, no refueling event for 0.020" dia leak
Monitor Sequence	HO2S monitor for front sensors completed and OK
Sensors/Components OK	MAF, IAT, VSS, ECT, CKP, TP, FTP, CPV, CVS
Monitoring Duration	360 seconds for 0.040" (see disablement conditions below) 60 seconds for 0.020" (see disablement conditions below)

Typical 0.020" EVAP monitor entry conditions, Phases 0 through 4:		
Entry condition	Minimum	Maximum
Engine off (soak) time	6 hours	
Time since engine start-up for 0.040"	330 seconds	1800 to 2700 seconds
Time since engine start-up for 0.020" idle test	30 seconds	600 seconds
Refueling event (for 0.020" idle test only)	none	
Intake Air Temp for 0.040"	40 °F	90 - 100 °F
Intake Air Temp for 0.020"	40 °F	90 °F
Vehicle Speed for cruise test, 0.040 and 0.020"	40 mph	80 mph
Vehicle Speed for idle test, 0.020"		3 mph
Fuel Fill Level for 0.040" (may be 30% to 85% for some large, >25 gal tanks)	15%	85%
Fuel Fill Level for 0.020" (may be 30% to 85% for some large, >25 gal tanks)	15%	85%
BARO (<8,000 ft altitude)	22.0 " Hg	
Engine Load	20%	70%
Purge Duty Cycle	75%	100%
Purge Flow	0.05 lbm/min	0.10 lbm/min
Fuel Tank Pressure Range	- 17 H ₂ O	16.06 H ₂ O

Typical 0.020" EVAP abort (fuel slosh) conditions for Phase 2:

Change in load: > 20% for 0.040"
Change in load: > 10% for 0.020"
Change in tank pressure: > 1 " H ₂ O for 0.040"
Change in tank pressure: > 1 " H ₂ O for 0.020"
Change in fuel fill level: > 15% for 0.040"
Change in fuel fill level: > 8% for 0.020"
Number of aborts: > 20 (may be up to 255)

Typical 0.020 EVAP monitor malfunction thresholds:

P1450 (Excessive vacuum): < -8.0 in H ₂ O over a 30 second evaluation time or > -4. in H ₂ O vapor generation.
P0455 (Gross leak): > -8.0 in H ₂ O over a 30 second evaluation time.
P0457 (Gross leak, cap off): > -8.0 in H ₂ O over a 30 second evaluation time after a refueling event.
P0442 (0.040" leak): > 2.5 in H ₂ O bleed-up over a 15 sec. evaluation time at 75% fuel fill. (Note: bleed-up and evaluation times vary as a function of fuel fill level and ambient temperature).
P0456 (0.020" leak): > 2.5 in H ₂ O bleed-up over a 30 sec. evaluation time at 75% fuel fill. (Note: bleed-up and evaluation times vary as a function of fuel fill level and ambient temperature)
P0442 vapor generation limit: < 2.5 in H ₂ O over a 100 second evaluation time.

J1979 Evaporative System Mode \$06 Data

Monitor ID	Test ID	Description for CAN	Units
\$3A	\$80	Phase 0 Initial tank vacuum and minimum vacuum limit (data for P1450 – excessive vacuum)	Pa
\$3A	\$81	Phase 4 Vapor generation minimum change in pressure and minimum vacuum limit (data for P1450, CPV stuck open)	Pa
\$3A	\$82	Phase 0 Initial tank vacuum and gross leak maximum vacuum limit (data for P0455/P0457 – gross leak/cap off)	Pa
\$3B	\$80	Phase 2 0.040" cruise leak check vacuum bleed-up and maximum vacuum limit (data for P0442 – 0.040" leak)	Pa
\$3C	\$80	Phase 2 0.020" idle leak check vacuum bleed-up and maximum vacuum limit (data for P0456 – 0.020" leak)	Pa

Note: Default values (0.0 Pa) will be displayed for all the above TIDs if the evap monitor has never completed. Each TID is associated with a particular DTC. The TID for the appropriate DTC will be updated based on the current or last driving cycle, default values will be displayed for any phases that have not completed.

EVAP System Monitor - 0.020" dia. Engine Off Natural Vacuum leak check

Some vehicles that meet enhanced evaporative requirements utilize an engine off natural vacuum (EONV) evaporative system integrity check that tests for 0.020" dia. leaks while the engine is off and the ignition key is off. The evap system integrity check uses a Fuel Tank Pressure Transducer (FTPT), a Canister Vent Solenoid (CVS) and Fuel Level Input (FLI) to find 0.020" diameter evap system leaks.

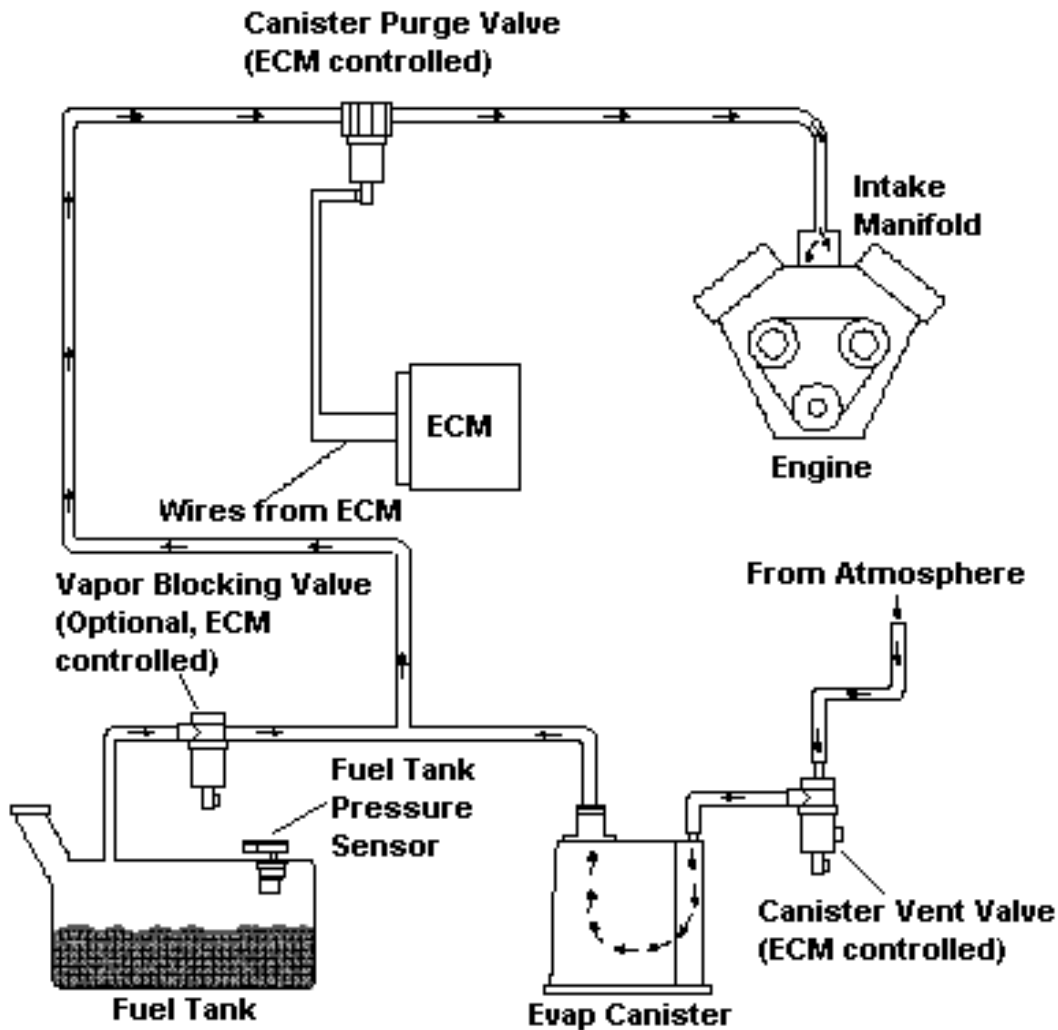

The Ideal Gas Law ($PV=mRT$) defines a proportional relationship between the Pressure and Temperature of a gas that is contained in a fixed Volume. Therefore, if a sealed container experiences a drop in temperature it will also experience a drop in pressure. In a vehicle, this happens when a sealed evaporative system cools after the engine has been run, or if it experiences a drop in temperature due to external environmental effects. This natural vacuum can be used to perform the leak check, hence the name Engine Off Natural Vacuum (EONV). Condensation of fuel vapor during cooling can add to the vacuum produced by the Ideal Gas Law.

In contrast to the vacuum produced by drops in temperature, an additional factor can be heat transfer to the evaporative system from the exhaust system immediately after key-off. Heat transfer from the exhaust at key-off aided by fuel vaporization may produce a positive pressure shortly after key-off, which can also be used for leak detection.

The EONV system is used to perform only the 0.020" leak check while 0.040" dia. leaks and larger (including fuel cap off) will continue to be detected by the conventional vacuum leak monitor performed during engine running conditions.

Ford's EONV implementation for California and Green State applications uses a Motorola Star-12 microprocessor in the PCM to process the required inputs and outputs while the rest of the PCM is not powered and the ignition key is off. The Star-12 microprocessor draws substantially less battery current than the PCM; therefore, powering only the Star-12 during engine-off conditions extends vehicle battery life and allows the EONV monitor to run more often. The PCM is the only difference between California/Green State and Federal vehicles.

Inputs to EONV Microprocessor

- Fuel Tank Pressure
- Battery Voltage

Outputs from EONV Microprocessor

- Canister Vent Solenoid
- 0.020" leak data

MY2005 EONV System Hardware Design

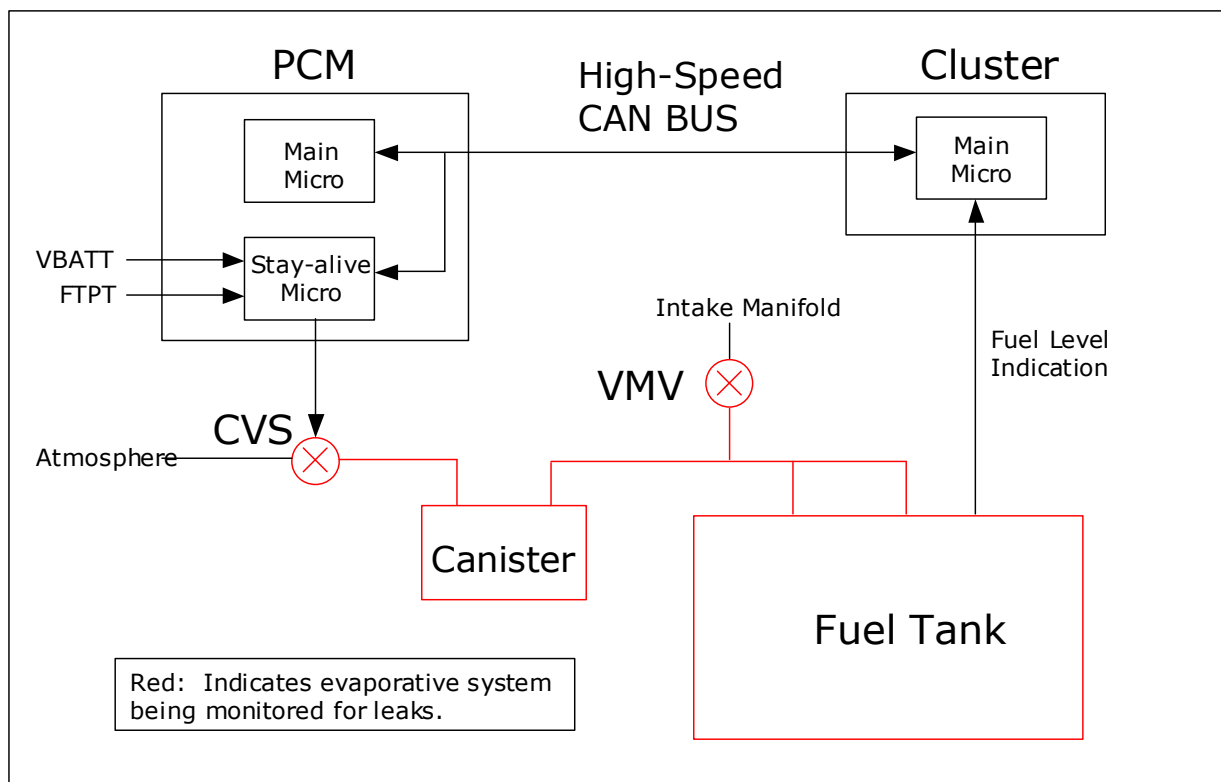

Phase 0- Stabilization Phase

The purpose of the Stabilization Phase is to allow tank pressure to stabilize after vehicle shutdown (i.e. ignition in the OFF position). During this phase, the Canister Vent Solenoid (CVS) is open, thus allowing the pressure in the fuel tank to stabilize at atmospheric pressure. The duration of the Stabilization Phase is approximately 2 minutes. A fuel volatility check is performed just prior to its completion.

The fuel volatility check measures tank pressure and will abort the test if more than 1.5 "H₂O is observed in the tank. Because the CVS is open during this test, it would take a good deal of fuel vaporization to produce this level of pressure on a vented system. As an example, this condition may occur when a customer performs a long drive with highly volatile, winter fuel on a 100-deg F day. Note: This feature is not used in most applications.

If the fuel volatility check passes, a Fuel Tank Pressure Transducer (FTPT) offset correction factor is learned as the last step of this phase. This correction factor is applied to pressure measurements in the next phase to improve FTPT accuracy.

Phase 1 – First Test Phase

At the start of this phase, the CVS is commanded shut, thus sealing up the entire evaporative system. If the system is sufficiently sealed, a positive pressure or vacuum will occur during depending on whether the tank temperature change is positive or negative. Other effects such as fuel vaporization and condensation within the fuel tank will also determine the polarity of the pressure. As the leak size increases, the ability to develop a positive pressure or vacuum diminishes. With a 0.020" leak, there may be no measurable positive pressure or vacuum at all depending on test conditions.

During this phase, tank pressure is continuously measured and compared to calibrated detection thresholds (both positive pressure and vacuum) that are based on fuel level and ambient temperature. If either the pressure or vacuum threshold is exceeded, the test will be considered a pass, and the monitor will proceed to "Phase 4 – Test Complete". If a positive plateau occurs in tank pressure without exceeding the pass threshold, the monitor will progress to "Phase 2 – Transition Phase". If a vacuum occurs, the monitor will remain in Phase 1 until the test times out after 45 minutes have elapsed since key-off, or the pass threshold for vacuum is exceeded. In either case, the monitor will transition to "Phase 4 – Test Complete."

Phase 2- Transition Phase

This phase will occur if a positive pressure plateau occurred in Phase 1 without the positive pass threshold being exceeded. At the start of the Transition Phase, the CVS is opened and the evaporative system is allowed to stabilize. The Transition Phase lasts approximately 2 minutes, and a new FTPT offset correction is learned just prior to its completion. The monitor will then progress to "Phase 3 – Second Test Phase".

Note: This phase is termed the Transition Phase because there is a chance that a vacuum will be seen in the next phase if a positive pressure plateau occurred in Phase 1. The reason for this is that a positive plateau may be coincident with vapor temperature starting to decrease, which is favorable for developing a vacuum in the fuel tank. This is not always the case, and it is possible to see a positive pressure in Phase 3 as well.

Phase 3- Second Test Phase

Upon completion of the Transition Phase, the CVS is commanded shut and the FTPT is monitored for any positive pressure or vacuum that develops. As with "Phase 1 – First Test Phase", if either the positive pressure or vacuum pass threshold is exceeded, the test is considered a pass and proceeds to "Phase 4 – Test Complete". Also, if the test times out after 45 minutes have elapsed since key-off, the test will be considered a fail (i.e. leak detected) and will also proceed to "Phase 4 – Test Complete".

Phase 4 – Test Complete

In this phase, the EONV test is considered complete for this key-off cycle. The resultant peak pressure and peak vacuum are stored along with total test time and other information. This information is sent to the main microprocessor via CAN at the next engine start. During this phase, the CVS is commanded open and the electrical components performing the EONV test are shutdown to prevent any further power consumption.

Test Aborts

During the EONV test, several parameters are monitored to abort the EONV test under certain conditions. The primary abort conditions are instantaneous changes in tank pressure and fuel level. They are used to detect refuel events and rapidly open the CVS upon detection of them. A list of abort conditions is given below.

Pre-2009 Model Year Fault Filtering

Test results are transferred to the main microprocessor upon detection where they are processed to determine if MIL illumination should occur. Because of the inherent variability in vapor temperature changes and fuel volatility, results from multiple EONV runs are normalized and averaged to determine if a malfunction should be set. Often, an average of four key-off EONV runs is used to determine a malfunction. If two malfunctions are set in a row, the MIL will be illuminated. Using this approach, a total of eight, key-off EONV runs will be required to illuminate the MIL. The in-use performance numerator will be incremented by one after each malfunction is detected.

Alternatively, the fault filtering can be calibrated so that an average of five key-off EONV runs are used to immediately illuminate the MIL. Using this approach, a total of five, key-off EONV runs will be required to illuminate the MIL. The in-use performance numerator will be incremented by two after the MIL is illuminated. Most new 2006 MY and later vehicles will be calibrated in this manner in order to improve EONV monitor completion frequency in the field.

Post-2009 Model Year Fault Filtering

To increase the IUMP (rate-based) numerator once per monitor completion, the fault filtering logic for EONV was revised. The logic incorporates several important CARB requirements. These are:

- Fast Initial Response (FIR): The first 4 tests after a battery disconnect or code clear will process unfiltered data to quickly indicate a fault. The FIR will use a 2-trip MIL. This will help the service technician determine that a fault has been fixed.
- Step-change Logic (SCL): The logic will detect an abrupt change from a no-fault condition to a fault condition. The SCL will be active after the 4th EONV test and will also use a 2-trip MIL. This will illuminate the MIL when a fault is instantaneously induced.
- Normal EWMA (NORM): This is the normal mode of operation and uses an Exponentially Weighted Moving Average (EWMA) to filter the EONV test data. It is employed after the 4th EONV test and will illuminate a MIL during the drive cycle where the EWMA value exceeds the fault threshold. (1 trip MIL). The recommended filter/time constant will produce filtering comparable to a previously-described 5-test average.

If there is a failure using any of the fault filtering logic shown above, a P0456 DTC will be set.

Phases of EONV Test

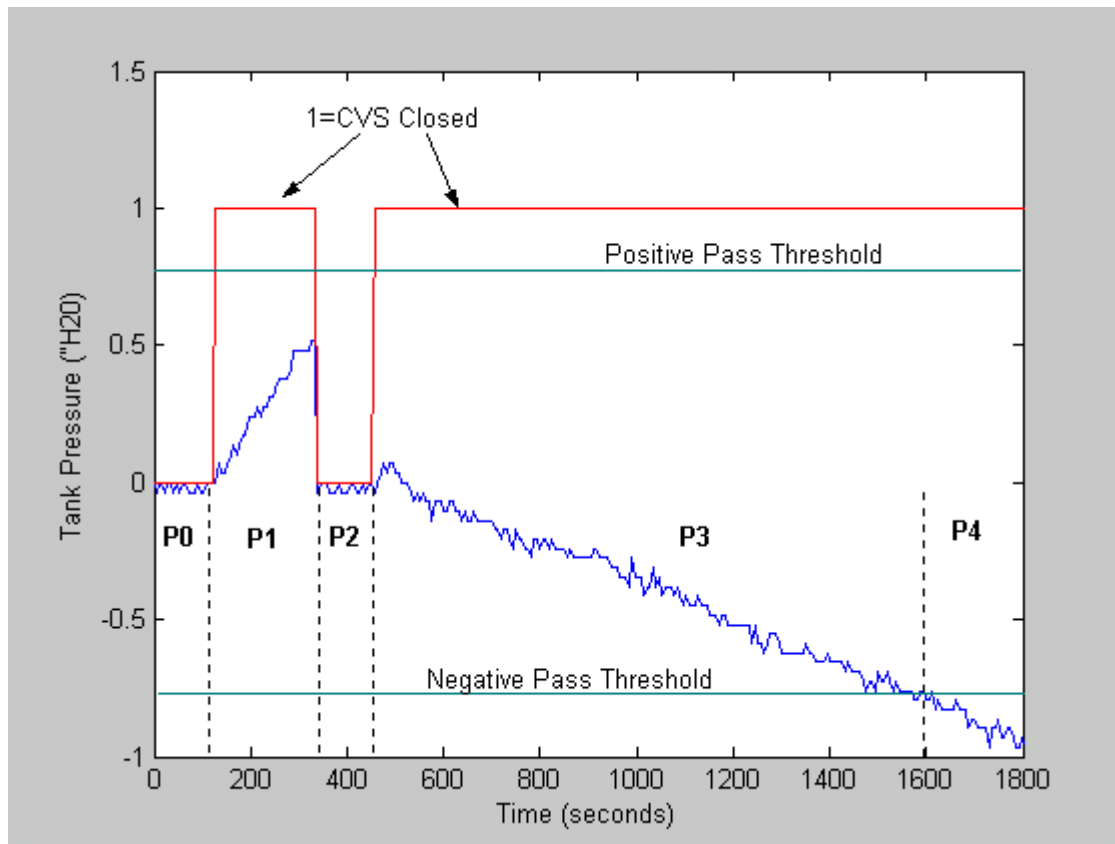

P0 = Phase 0, Stabilization Phase – With CVS open, Tank Pressure is allowed to stabilize. A fuel volatility test is performed and FTPT offset correction is learned if volatility test passes.

P1 = Phase 1, First Test Phase – CVS is closed and pressure peaks below positive pass threshold sending test to Phase 2. If the positive pass threshold were exceeded, the test would have completed and a pass would have been recorded.

P2 = Phase 2, Transition Phase – CVS is opened and a second stabilization phase occurs. A second FTPT offset is learned during this time.

P3 = Phase 3, Second Test Phase – CVS is closed again and a vacuum develops that eventually exceeds the negative pass threshold. When this occurs the test proceeds to Phase 4, test complete.

P4 = Phase 4, Test Complete – CVS opens (not pictured in above data file), results are recorded, and stay-alive electronics shutdown.

0.020" EONV EVAP Monitor Operation:	
DTCs	P0456 (0.020" leak) P260F (Evaporative System Monitoring Processor Performance)
Monitor execution	Once per key-off when entry conditions are met during drive. Monitor will run up to 2 times per day, or 90 cumulative minutes per day (whichever comes first)
Monitor Sequence	none
Sensors/Components OK	EONV Processor, Canister Vent Solenoid, Fuel Tank Pressure Sensor, Fuel Level Input, Vapor Management Valve, CAN communication link
Monitoring Duration	45 minutes in key-off state if fault present. Tests will likely complete quicker if no fault is present.

Typical 0.020" EONV EVAP monitor entry conditions:		
Entry conditions seen just prior to engine off	Minimum	Maximum
Engine off (soak) time	3.5 - 6 hours	
Time since engine start-up	20 minutes	90 minutes
Ambient Temperature at start-up	40 °F	95 °F
Battery Voltage	11 volts	
Number of completed tests in 24hr cycle		2
Cumulative test time in 24hr cycle		90 minutes
Fuel level	15%	85%
ECU time since power-up	180 seconds	
Flex fuel inference complete	Learned	
Summation of air mass since start ensures that vehicle has been operated off idle.		
Ratio of drive time to (drive + soak) time. (This allows for the driver to key-off for a short time without losing the initial soak condition.)	0.8	

Typical 0.020" EONV EVAP key-off abort conditions:

Tank pressure at key-off > 1.5" H ₂ O during stabilization phase (indicates excessive vapor)
Tank pressure not stabilized for tank pressure offset determination
Rapid change in tank pressure > 0.5"H ₂ O (used for refuel/slosh detection)
Rapid change in fuel level > 5% (used for refuel/slosh detection)
Battery voltage < 11 Volts
Rapid change in battery voltage > 1 Volt
Loss of CAN network
Canister Vent Solenoid fault detected
Driver turns key-on

Typical 0.020 EONV EVAP monitor malfunction thresholds:

P0456 (0.020" leak): < 0.75 in H₂O pressure build and
 < 0.50 in H₂O vacuum build over a 45 minute maximum evaluation time

Note: EONV monitor can be calibrated to illuminate the MIL after two malfunctions (an average of four key-off EONV tests, eight runs in all) or after a single malfunction (an average of five key-off EONV tests, five runs in all), or using EWMA with Fast Initial Response and Step Change Logic. Most new 2006 MY and later vehicles will use the five-run approach, most new 2009 MY and later use the EWMA approach.

J1979 EONV EVAP monitor Mode \$06 Data

Monitor ID	Comp ID	Description for CAN	Units
\$3C	\$81	EONV Positive Pressure Test Result and Limits	Pa
\$3C	\$82	EONV Negative Pressure (Vacuum) Test Result and Limits	Pa
\$3C	\$83	Normalized Average of Four EONV Tests Results and Limits (where 0 = pass, 1 = fail)	unitless

Note: Default values (0.0) will be displayed for all the above TIDs if the evap monitor has never completed. The appropriate TID will be updated based on the current or last driving cycle, default values will be displayed for any phases that have not completed.

EVAP System Monitor Component Checks

Additional malfunctions that are identified as part of the evaporative system integrity check are as follows:

The **Canister Purge Valve (CPV)** output circuit is checked for opens and shorts (P0443)

Note that a stuck closed CPV generates a P0455, a leaking or stuck open CPV generates a P1450.

Canister Purge Valve Check Operation:	
DTCs	P0443 – Evaporative Emission System Purge Control Valve "A" Circuit
Monitor execution	continuous
Monitor Sequence	None
Sensors OK	not applicable
Monitoring Duration	5 seconds to obtain smart driver status

Typical Canister Purge Valve check malfunction thresholds:
P0443 (CPV): open/shorted at 0 or 100% duty cycle

The **Canister Vent Solenoid** output circuit is checked for opens and shorts (P1451 or P0446), a stuck closed CVS generates a P1450, a leaking or stuck open CVS generates a P0455.

Canister Vent Solenoid Check Operation:	
DTCs	P1451 or P0446 – Canister Vent Solenoid Circuit
Monitor execution	continuous
Monitor Sequence	None
Sensors OK	not applicable
Monitoring Duration	5 seconds to obtain smart driver status

Typical Canister Vent Solenoid check malfunction thresholds:
P1451 or P0446 (Canister Vent Solenoid Circuit): open/shorted

The **Evap Switching Valve** (EVAPSV) output circuit is checked for opens and shorts (P2418).

Evap Switching Valve Check Operation:	
DTCs	P2418 - Evap Switching Valve Circuit
Monitor execution	continuous
Monitor Sequence	None
Sensors OK	not applicable
Monitoring Duration	5 seconds to obtain smart driver status

Evap Switching Valve check malfunction thresholds:
P2418 (Evap Switching Valve Circuit): open/shorted

The **Fuel Tank Pressure Sensor** input circuit is checked for out of range values (P0452 short, P0453 open), noisy readings (P0454 noisy) and an offset (P0451 offset).

Note that carryover 2004 MY software and 2003 MY and earlier software will set P0451 for the noisy sensor test.

Note that an open power input circuit or stuck check valve generates a P1450.

Fuel Tank Pressure Sensor Transfer Function		
$FTP \text{ volts} = [V_{ref} * (0.14167 * \text{Tank Pressure}) + 2.6250] / 5.00$		
Volts	A/D Counts in PCM	Fuel Tank Pressure, Inches H ₂ O
0.100	20	-17.82
0.500	102	-15.0
1.208	247	-10.0
2.625	464	0
3.475	712	6.0
4.750	973	15.0
4.90	1004	16.06

Fuel Tank Pressure Sensor Check Operation:	
DTCs	P0452 – Fuel Tank Pressure Sensor Circuit Low P0453 – Fuel Tank Pressure Sensor Circuit High P0454 – Fuel Tank Pressure Sensor Intermittent/Erratic (noisy)
Monitor execution	continuous
Monitor Sequence	None
Sensors OK	not applicable
Monitoring Duration	5 seconds for electrical malfunctions, 16.7 minutes for noisy sensor test

Typical Fuel Tank Pressure Sensor check malfunction thresholds:P0452 (Fuel Tank Pressure Sensor Circuit Low): < -17.82 in H₂OP0453 (Fuel Tank Pressure Sensor Circuit High): > 16.06 in H₂OP0454 (Fuel Tank Pressure Sensor Circuit Noisy): > 14 in H₂O change between samples, sampled every 10 seconds, more than 100 fault occurrences**Fuel Tank Pressures Sensor Offset Check Operation**

DTCs	P0451 – Fuel Tank Pressure Sensor Range/Performance (offset)
Monitor execution	once per driving cycle
Monitor Sequence	No P0443 or P1450 DTCs
Sensors OK	not applicable
Monitoring Duration	< 1 second

Typical Fuel Tank Pressure Sensor Offset Check Entry Conditions:

Entry condition	Minimum	Maximum
Ignition key on, engine off, engine rpm		0 rpm
Purge Duty Cycle		0%
Engine off (soak) time	2 hours	
Battery Voltage	11.0 Volts	

Typical Fuel Tank Pressure Sensor Offset Check Malfunction Thresholds:Fuel tank pressure at key on, engine off is 0.0 in H₂O +/- 2.0 in H₂O

The **Fuel Level Input** is checked for out of range values (opens/ shorts). The FLI input can be hardwired to the PCM or be obtained from the serial data link, typically from the instrument cluster. If the FLI signal is open or shorted, a P0460 is set. Some software will be able to discriminate between an open and short and set the appropriate DCT (P0462 circuit low and P0463 circuit high).

Finally, the Fuel Level Input is checked for noisy readings. If the FLI input changes from an in-range to out-of-range value repeatedly, a P0461 DTC is set.

Fuel Level Input Check Operation:

DTCs	P0460 – Fuel Level Input Circuit P0461 – Fuel Level Input Circuit Noisy P0462 – Fuel Level Input Circuit Low P0463 – Fuel Level Input Circuit High
Monitor execution	continuous
Monitor Sequence	None
Sensors OK	not applicable
Monitoring Duration	30 seconds for electrical malfunctions, Fuel Level Stuck test (P0460) can take up to 120 miles to complete

Typical Fuel Level Input check malfunction thresholds:

P0460 or P0462 (Fuel Level Input Circuit Low): < 5 ohms

P0460 or P0463 (Fuel Level Input Circuit High): > 200 ohms

P0461 (Fuel Level Input Noisy): > 100 circuit low or circuit high exceedences, sampled every 0.100 seconds

The FLI signal is also checked to determine if it is stuck. The PCM calculates the amount of fuel being consumed by accumulating fuel pulse width. (Fuel consumed and fuel gauge reading range are both stored in KAM and reset after a refueling event or DTC storage.) If there is an insufficient corresponding change in fuel tank level, a P0460 DTC is set.

Different malfunction criteria are applied based on the range in which the fuel level sensor is stuck.

In the range between 15% and 85%, a 30% difference between fuel consumed and fuel used is typical. The actual value is based on the fuel economy of the vehicle and fuel tank capacity.

In the range below 15%, a 40% difference between fuel consumed and fuel used is typical. The actual value is based on reserve fuel in the fuel tank and the fuel economy of the vehicle.

In the range above 85%, a 60% difference between fuel consumed and fuel used is typical. The actual value is based on the overfill capacity of the fuel tank and the fuel economy of the vehicle. Note that some vehicles can be overfilled by over 6 gallons.

Fuel Level Input Stuck Check Operation:

DTCs	P0460 – Fuel Level Input Circuit Stuck
Monitor execution	continuous
Monitor Sequence	None
Sensors OK	not applicable
Monitoring Duration	Between 15 and 85%, monitoring can take from 100 to 120 miles to complete

Typical Fuel Level Input Stuck check malfunction thresholds:

P0460 (Fuel Level Input Stuck):

Fuel level stuck at greater than 85%: > 40% difference in calculated fuel tank capacity consumed versus change in fuel level input reading

Fuel level stuck at less than 85%: > 40% difference in calculated fuel tank capacity consumed versus change in fuel level input reading

Fuel level stuck between 15% and 85%: > 60% difference in calculated fuel tank capacity consumed versus change in fuel level input reading

Evap Switching Valve (EVAPSV) Diagnostics

The Evap Switching Valve (EVAPSV) is included on HEV applications for 2009 Model Year. It is very similar to the Fuel Tank Isolation Valve (FTIV) used in previous model years. The Evap Switching Valve is also known as a Vapor Blocking Valve (VBV). The purpose of the EVAPSV is to isolate the fuel tank from the rest of the evaporative system so that the Canister Purge Valve (CPV) can purge more aggressively with minimal risk of purge vapor slugs being ingested into the intake.

The EVAPSV is normally closed during engine operation, but may vent during a drive to relieve positive pressure. The exact pressure points at which the valve opens and closes are vehicle dependent. When the vehicle is in a key-off state, the EVAPSV is not powered and the valve is open.

The VBV circuit and functional diagnostics will set the following DTCs:

- P2418 – EVAPSV circuit fault
- P2450 – EVAPSV stuck open fault

The EVAPSV circuit diagnostics are very similar to that of the Canister Purge Valve (CPV) and Canister Vent Solenoid (CVS). See Evap System Monitor Component Checks below.

A diagram of an evaporative system with an EVAPSV (shown as a VBV) is shown below:

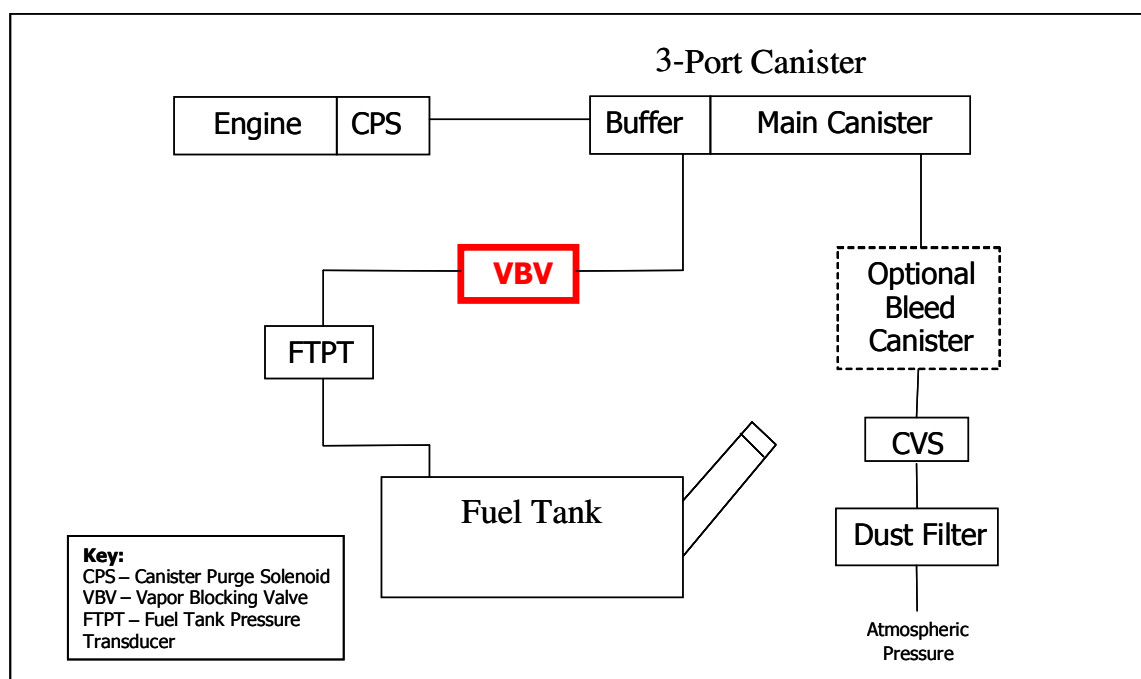

The Evaporative System monitor performs a functional check of the EVAPSV in Phase 3 of the evap monitor cruise tests if the 0.040" leak test passes. At the end of Phase 2, tank pressure will be in the range of -8 to -5 "H₂O and the EVAPSV will be open. At the beginning of Phase 3, the EVAPSV is commanded closed and the CVS is commanded open. If the EVAPSV fails to close, there will be a rapid pressure loss in the fuel tank. If this pressure loss exceeds a calibrated threshold, a P2450 DTC is set. (Requires 2 or 3 failures in a row during a driving cycle (calibratable)). If the fault is present on a second driving cycle, the MIL will be illuminated.

EVAP Switching Valve (EVAPSV) Monitor Operation:	
DTC	P2450
Monitor execution	once per driving cycle
Monitor Sequence	Runs after evap 0.040" cruise test
Sensors/Components OK	MAF, IAT, VSS, ECT, CKP, TP, FTP, CPV, CVS
Monitoring Duration	30 seconds (see disablement conditions below)

Typical EVAP Switching Valve (EVAPSV) monitor entry conditions:		
Entry condition	Minimum	Maximum
0.040" Cruise Test completes		

Typical EVAP Switching Valve (EVAPSV) abort conditions:
Change in fuel fill level: > 15%

Typical EVAP Switching Valve (EVAPSV) malfunction thresholds:
P2418: Presence of short, open, or intermittent fault for more than 5 seconds
P2450: Pressure loss > 3" H ₂ O during phase 3.

J1979 Evaporative System Mode \$06 Data			
Test ID	Comp ID	Description	Units
\$3D	\$82	Vapor blocking valve performance	Pa
Note: Default values (0.0 Pa) will be displayed for all the above TIDs if the evap monitor has never completed. Each TID is associated with a particular DTC. The TID for the appropriate DTC will be updated based on the current or last driving cycle, default values will be displayed for any phases that have not completed.			

Blocked Purge Line Diagnostics

If an in-line Fuel Tank Pressure Transducer is used, it is possible for a blockage to occur between the Fuel Tank Pressure Transducer (FTPT) and fuel tank. If this occurs, the evap monitor would run and pass all leak check diagnostics even if there is a leak at the fuel cap. (The blockage will make the system look sealed despite the leak.) The blocked line diagnostic looks for a rapid drop in pressure during Phase 0 of the cruise test. This rapid pressure drop occurs because the Canister Purge Valve (CPV) applies a vacuum to just the canister and evap lines. Upon seeing an excessively fast pressure drop in Phase 0, the evap monitor will invoke a special execution of Phase 3 & 4 where a CPV pressure pulse is applied to the evap system. This pressure pulse is at a very low flow and short duration (0.5 -1.0 seconds) to avoid drivability issues. If this intrusive test fails, the Phase 0 test and the intrusive test are repeated 2 or 3 times prior to setting a P144A DTC.

Diagram of an evaporative system with a blockage is shown below:

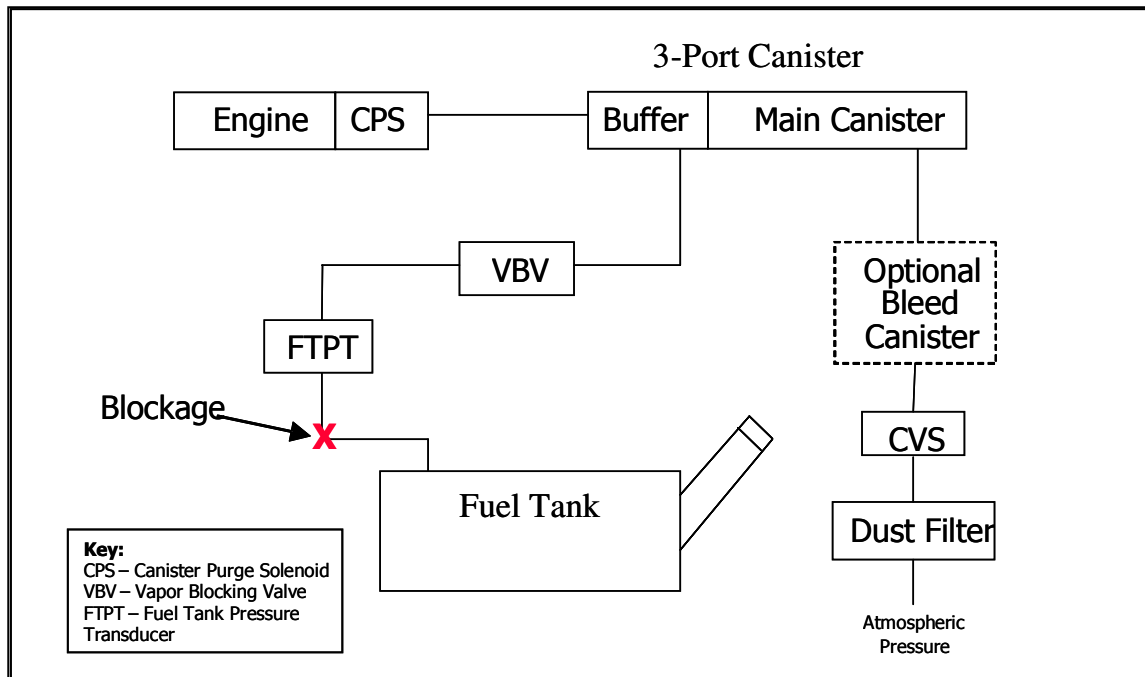

EVAP Blocked Line Monitor Operation:	
DTC	P144A
Monitor execution	once per driving cycle
Monitor Sequence	Runs during Phase 0 of evap 0.040" cruise test. Performs an intrusive test in Phases 3 & 4 to confirm a fault.
Sensors/Components OK	MAF, IAT, VSS, ECT, CKP, TP, FTP, CPV, CVS
Monitoring Duration	30 seconds (see disablement conditions below)

Typical Blocked Line monitor entry conditions:		
Entry condition	Minimum	Maximum
General 0.040" Cruise Test conditions apply		
Air mass high enough for intrusive portion of test	0.05 (lb/min)	
Manifold vacuum high enough for intrusive portion of test	2 "Hg	
Not in open loop fueling		
CPV purging		

Typical EVAP Blocked Line abort conditions:
All items cited under entry conditions apply.

Typical EVAP Blocked Line malfunction thresholds:
P144A: Phase 0 portion of test delta pressure < -5 "H ₂ O/sec
P144A: Phase 3 & 4 (intrusive test) pressure response < -2 "H ₂ O

J1979 Evaporative System Mode \$06 Data			
Test ID	Comp ID	Description	Units
\$3D	\$80	Blocked Evap System Line - Screening test	Pa/sec
\$3D	\$81	Blocked Evap System Line - Fault confirmation test	Pa
Note: Default values (0.0) will be displayed for all the above TIDs if the evap monitor has never completed. Each TID is associated with a particular DTC. The TID for the appropriate DTC will be updated based on the current or last driving cycle, default values will be displayed for any phases that have not completed.			

Fuel System Monitor

The adaptive fuel strategy uses O2 sensors for fuel feedback. The fuel equation includes short and long term fuel trim modifiers:

$$\text{FUEL MASS} = \frac{\text{AIR MASS} * \text{SHRTFT} * \text{LONGFT}}{\text{EQUIV_RATIO} * 14.64}$$

Where:

Fuel Mass = desired fuel mass

Air Mass = measured air mass, from MAF sensor

SHRTFT = Short Term Fuel Trim, calculated

LONGFT = Long Term Fuel Trim, learned table value, stored in Keep Alive Memory

EQUIV_RATIO = Desired equivalence ratio, 1.0 = stoich, > 1.0 is lean, < 1.0 is rich

14.64 = Stoichiometric ratio for gasoline

A conventional O2 sensor (not a wide-range sensor) can only indicate if the mixture is richer or leaner than stoichiometric. During closed loop operation, short term fuel trim values are calculated by the PCM using oxygen sensor inputs in order to maintain a stoichiometric air/fuel ratio. The PCM is constantly making adjustments to the short term fuel trim, which causes the oxygen sensor voltage to switch from rich to lean around the stoichiometric point. As long as the short term fuel trim is able to cause the oxygen sensor voltage to switch, a stoichiometric air/fuel ratio is maintained.

When initially entering closed loop fuel, SHRTFT starts 1.0 and begins adding or subtracting fuel in order to make the oxygen sensor switch from its current state. If the oxygen sensor signal sent to the PCM is greater than 0.45 volts, the PCM considers the mixture rich and SHRTFT shortens the injector pulse width. When the cylinder fires using the new injector pulse width, the exhaust contains more oxygen. Now when the exhaust passes the oxygen sensor, it causes the voltage to switch below 0.45 volts, the PCM considers the mixture lean, and SHRTFT lengthens the injector pulse width. This cycle continues as long as the fuel system is in closed loop operation.

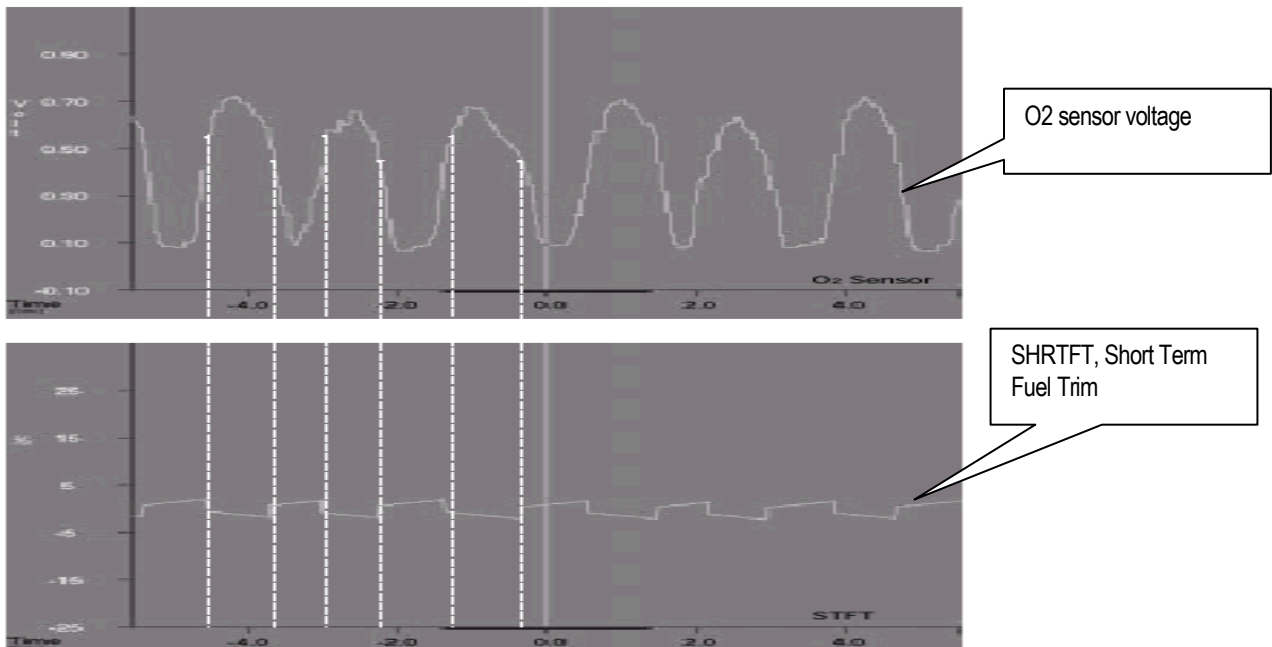

As fuel, air, or engine components age or otherwise change over the life of the vehicle, the adaptive fuel strategy learns deviations from stoichiometry while running in closed loop fuel. Corrections are only learned during closed loop operation, and are stored in the PCM as long term fuel trim values (LONGFT). They may be stored into an 8x10 rpm/load table or they may be stored as a function of air mass. LONGFT values are only learned when SHRTFT values cause the oxygen sensor to switch. If the average SHRTFT value remains above or below stoichiometry, the PCM “learns” a new LONGFT value, which allows the SHRTFT value to return to an average value near 1.0. LONGFT values are stored in Keep Alive Memory as a function of air mass. The LONGFT value displayed on the scan tool is the value being used for the current operating condition.

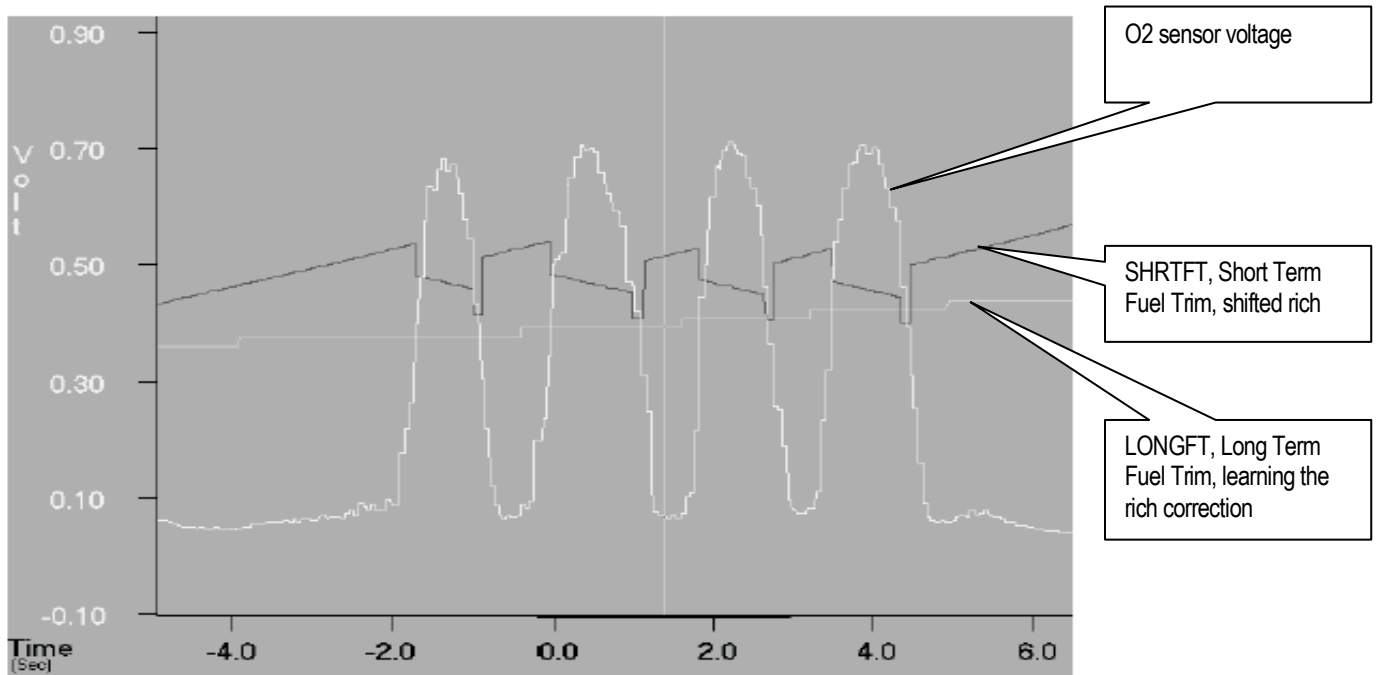

As components continue to change beyond normal limits or if a malfunction occurs, the long-term fuel trim values will reach a calibratable rich or lean limit where the adaptive fuel strategy is no longer allowed to compensate for additional fuel system changes. Long term fuel trim corrections at their limits, in conjunction with a calibratable deviation in short term fuel trim, indicate a rich or lean fuel system malfunction.

Note that in the PCM, both long and short-term fuel trim are multipliers in the fuel pulse width equation. Scan tools normally display fuel trim as percent adders. If there were no correction required, a scan tool would display 0% even though the PCM was actually using a multiplier of 1.0 in the fuel pulse width equation.

Fuel System Monitor

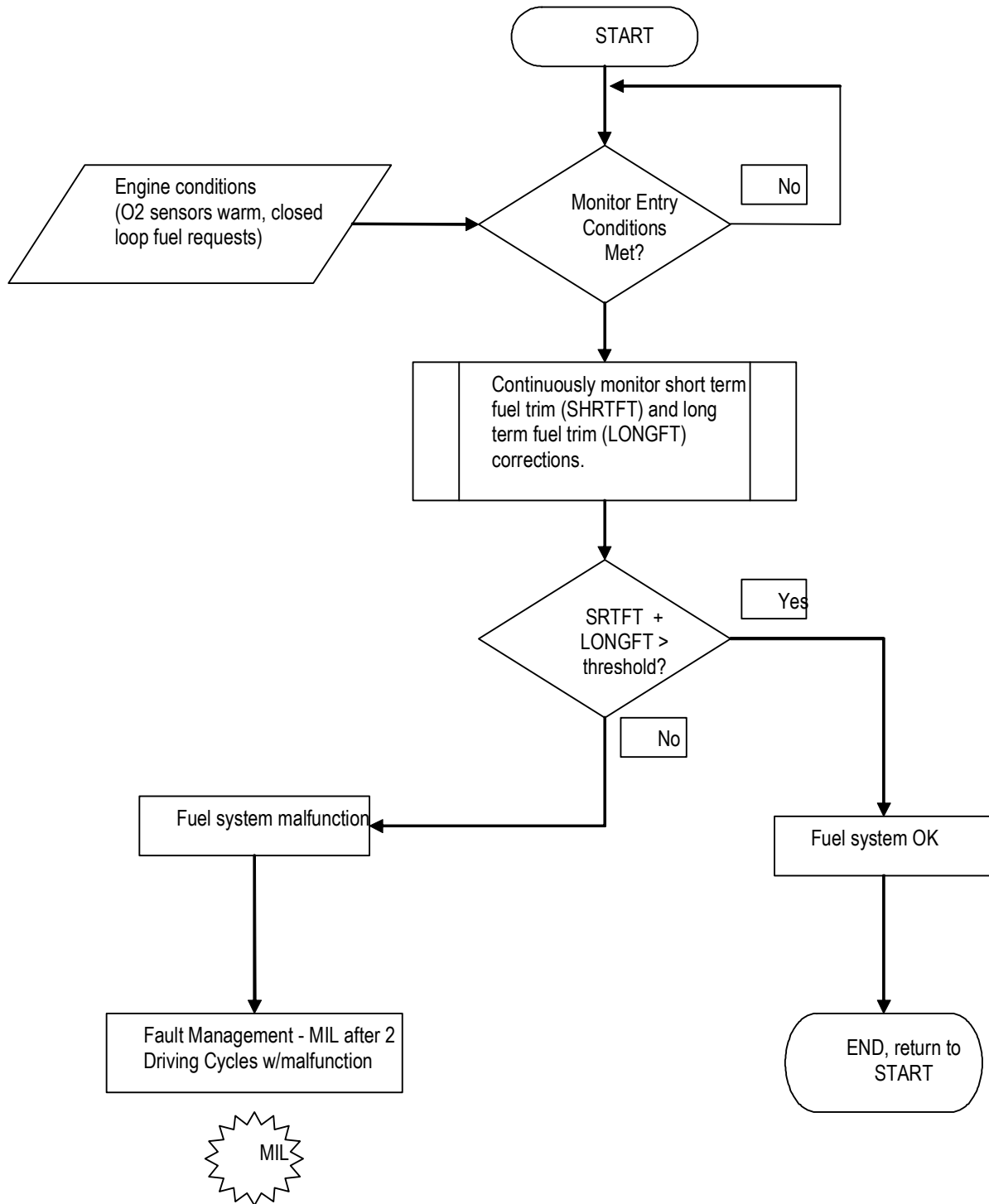

Fuel Monitor Operation:	
DTCs	P0171 Bank 1 Lean, P0174 Bank 2 Lean P0172 Bank 1 Rich, P0175 Bank 2 Rich
Monitor execution	continuous while in closed loop fuel
Monitor Sequence	none
Sensors OK	Fuel Rail Pressure (if available), IAT, CHT/ECT, MAF, TP
Monitoring Duration	2 seconds to register malfunction

Typical fuel monitor entry conditions:		
Entry condition	Minimum	Maximum
Engine Coolant Temp	150 °F	230 °F
RPM Range	idle	
Air Mass Range	0.75 lb/min	
Purge Duty Cycle	0%	0%

Typical fuel monitor malfunction thresholds:
Long Term Fuel Trim correction cell currently being utilized in conjunction with Short Term Fuel Trim: Lean malfunction: LONGFT > 25%, SHRTFT > 5% Rich malfunction: LONGFT < 25%, SHRTFT < 10%

Flex Fuel Operation

Ford Motor Company is cooperating with the Department of Energy in providing customers with vehicles capable of using alcohol-blended fuels. These fuels are renewable and can lower some engine emission byproducts. The original 1993 Taurus vehicle hardware and calibration were designed for use on any combination of gasoline or methanol up to 85% methanol. Current flex fuel vehicles, however, are no longer designed for methanol, but are designed to be compatible with any combination of gasoline and ethanol, up to 85% ethanol.

This flexible fuel capability allows the vehicle to be usable in all regions of the country, even as the alcohol infrastructure is being built. Operation of a vehicle with the alcohol-blended fuels is intended to be transparent to the customer. Drivability, NVH, and other attributes are not notably different when using the alcohol-blended fuels. The higher octane of alcohol-blended fuels allows a small increase in power and performance (approximately 4%), but this is offset by the lower fuel economy (approximately 33%) due to the lower energy content. Cold starts with alcohol-blended fuels are somewhat more difficult than with gasoline due to the lower volatility of alcohol-blended fuels; 10% vaporization occurs at approximately 100 °F for gasoline vs. 160 °F for 85% ethanol. Ethanol requires approximately 37% more flow than gasoline due to a lower heating value (29.7 vs. 47.3 MJ/kg). Consequently, Flex Fuel vehicles require higher flow injectors than their gasoline counterparts. This results in a smaller fuel pulse widths with gasoline and makes the task of purging the canister more difficult during idles and decels.

In order to maintain proper fuel control, the PCM strategy needs to know the stoichiometric Air/Fuel Ratio for use in the fuel pulse width equation. On pre-2000 MY flex fuel vehicles, the percent alcohol in the fuel was determined by reading the output of the Flex fuel Sensor. The percent alcohol was stored in a register called Percent Methanol (PM). Although current alcohol-blended fuels only include ethanol, the percent methanol nomenclature has persisted. On 2000 MY and later vehicles, the Flex Fuel Sensor has been deleted and PM is inferred. The strategy to infer the correct A/F Ratio (AFR) relies on the oxygen sensor input to maintain stoichiometry after vehicle refueling occurs.

The relationship between PM and AFR is shown in the table below.

Stoich Air Fuel Ratio = 14.64 - 5.64 * PM	
PM (percent alcohol)	Stoichiometric AFR
0.00 (100 % gasoline)	14.64
0.05	14.36
0.10 (standard gasoline)	14.08
0.15	13.79
0.20	13.51
0.25	13.23
0.30	12.95
0.35	12.67
0.40	12.38
0.45	12.10
0.50	11.82
0.55	11.54
0.60	11.26
0.65	10.97
0.70	10.69
0.75	10.41
0.80	10.13
0.85 (standard E85)	9.85
0.90	9.56
0.95	9.28
1.00 (100% ethanol)	9.00

The fuel level input is used to determine if a refueling event has occurred, either after the initial start or while the engine is running. If refueling event is detected (typically calibrated as a 10% increase in fuel level), the PCM tracks the "old" fuel being consumed by the engine. After a calibrated amount of "old" fuel has been consumed from the fuel lines, fuel rail, etc., the "new" fuel is assumed to have reached the engine. Normal long term fuel trim learning and purge control are temporarily disabled along with the evaporative system monitor and fuel system monitor to allow the composition of the fuel to be determined. The filtered value of short-term fuel trim is used during closed loop to adjust AFR in order to maintain stoichiometry. During learning, all changes in AFR are stored into the AFRMOD register. As updates are made to the AFRMOD register, the fuel composition register (PM) is updated and stored in Keep Alive Memory. Learning continues until the inference stabilizes with stabilized engine operating conditions. The PM inference and engine operating conditions are considered to have stabilized when all of the following conditions are satisfied:

- ECT indicates the engine has warmed up (typically 170 °F) or an ECT related fault is present.
- Enough "new" fuel has been consumed (typically 0.5 lb - vehicle dependant) to insure fuel is adequately mixed.
- The filtered value of short term fuel trim is in tight fuel control around stoichiometry, (typically +/- 2%) for at least 5 O2 sensor switches or AFRMOD is at a clip.
- The engine has been operated for a calibratable length of time, based on ECT temperature at start (typically 200 sec. at 40 °F and 30 sec at 200 °F) or an ECT related fault is present.
- The engine has been operating in closed loop fuel, with the brake off, within a calibratable (off-idle) air mass region (typically 2.4 to 8 lb/min) for 5 seconds, to minimize the effect of errors such as vacuum leaks.

Once the value of PM has stabilized (usually about 7 miles of driving), AFRMOD and PM are locked and deemed to be "mature." After PM is deemed "mature," normal fuel trim learning and purge control are re-enabled along with the fuel system monitor and evaporative system monitor. Any observed fueling errors from that point on are rolled into normal long term fuel trim (via adaptive fuel learning).

All remaining OBD-II monitors remain enabled unless AFR is observed to be changing. If AFR is changing, all monitors (except CCM and EGR) are disabled until the AFR stabilizes. This logic is same as was used for FFV applications that used a sensor. The AFR rate of change required to disable OBD-II monitor operation is typically 0.1 A/F (rate is based on the difference between a filtered value and the current value). For a fuel change from gasoline to E85 or vice versa, AFR typically stabilizes after 2 to 3 minutes on an FTP cycle.

If a large refueling event is detected (typically calibrated as a 40% to 50% increase in fuel level), the PCM strategy tries to assign the "new" fuel as gasoline or ethanol (E85) on the assumption that the only fuels available are either gasoline or E85. The strategy performs this fuel assignment to gasoline or ethanol (E85) only if the "old" and the "new" stabilized inferred fuel composition values are within a specified amount of each other (typically 5-10%), indicating that the fuel in the tank is the same as the fuel that was added and therefore must be either gasoline or ethanol (E85). If the "old" and "new" stabilized inferred fuel composition values are not near each other, the fuel added must be different from what was in the tank and the strategy retains the current inferred value of PM until the next refuel. By assigning the fuel to gasoline or ethanol (E85) in this manner, normal fuel system errors can be learned into normal long term fuel trip for proper fuel system error diagnosis.

After a battery disconnect or loss of Keep Alive Memory, the strategy will infer AFR immediately after going into closed loop fuel operation. A vehicle that previously had fuel system errors learned into long term fuel trim will infer incorrect values of AFR. After the value of AFR is determined, it is fixed until the next refueling event. If the next refueling event is performed with the same fuel (either E85 or gasoline), the value of AFR will not change. The fuel is then assigned to be E85 or gasoline as explained above. The long term fuel trim will again be a reliable indication of normal fuel system errors.

Only one large tank fill is required to assign the fuel as being either gasoline or ethanol, if the inferred AFR did not change significantly. If AFR did change significantly, several tank fills with the same fuel may be necessary to assign the fuel as gasoline or ethanol.

As the vast majority of vehicles are expected to be operated with gasoline, the initial value of AFR is set to gasoline. This is the starting point for the AFR after a battery disconnect and will allow for normal starting. Some vehicles may have E85 in the fuel tank after having a battery disconnect, and may not have a good start or drive away. The startability of alcohol-blended fuels at extreme cold temperatures (< 0 °F) is difficult under normal conditions; these vehicles may be required to be towed to a garage for starting if a battery disconnect occurs.

Front HO2S Monitor

Front HO2S Signal

The time between HO2S switches is monitored after vehicle startup when closed loop fuel has been requested, during closed loop fuel conditions and when open loop fuel has been requested due to an HO2S fault. Excessive time between switches with short term fuel trim at its limits (up to +/- 40%), or no switches since startup indicate a malfunction. Since "lack of switching" malfunctions can be caused by HO2S sensor malfunctions or by shifts in the fuel system, DTCs are stored that provide additional information for the "lack of switching" malfunction. Different DTCs indicate whether the sensor was always indicates lean/disconnected (P1131 or P2195, P1151 or P2197), or always indicates rich (P1132 or P2196, P1152 or P2198).

Characteristic Shift Downward (CSD) is a deviation from the normal positive voltage output of the HO2S signal to negative voltage output. During a full CSD, the HO2S signal shifts downward (negative) by 1 volt. CSD occurs when the reference chamber of the HO2S becomes contaminated, causing negative HO2S voltage to be generated. Even though CSD can occur in both front and rear HO2S signals, only the front HO2S are compensated for CSD. The CSD compensation algorithm must not be in the process of driving fuel to bring the HO2S out of CSD before running some of the HO2S monitors.

2005 MY and later vehicles monitor the HO2S signal for high voltage, in excess of 1.1 volts and store a (P0132, P0152) DTC. An over voltage condition is caused by a HO2S heater or battery power short to the HO2S signal line.

HO2S "Lack of Switching" Operation:	
DTCs	P1131 or P2195 - Lack of switching, sensor indicates lean, Bank 1 P1132 or P2196 - Lack of switching, sensor indicates rich, Bank 1 P1151 or P2197 - Lack of switching, sensor indicates lean, Bank 2 P1152 or P2198 - Lack of switching, sensor indicates rich, Bank 2
Monitor execution	continuous, from startup and while in closed loop fuel or open loop fuel due to HO2S fault
Monitor Sequence	None
Sensors OK	ECT, IAT, MAF, VSS, TP, ETC, FRP, DPFE EGR, VCT, VMV/EVMV, CVS, FTP, CKP, CMP, ignition coils, injectors, no misfire DTCs, no system failures affecting fuel, no EVAP gross leak failure, front HO2S heaters OK, no front HO2S over voltage
Monitoring Duration	30 seconds to register a malfunction

Typical HO2S “Lack of Switching” entry conditions:		
Entry condition	Minimum	Maximum
Closed Loop or Open Loop Requested due to HO2S fault		
Stream 1 HO2S not in CSD recovery mode		
No fuel flow entering thru PCV during cold start when flashing off fuel in oil (for O2 Sensor Stuck Rich DTCs only)		
Inferred Ambient Temperature	-40 °F	
Time within entry conditions	10 seconds	
Fuel Tank Pressure		10 in H ₂ O
Fuel Level	15%	
Battery Voltage	11.0 Volts	18.0 Volts

Typical HO2S “Lack of Switching” malfunction thresholds:
< 5 switches since startup for > 30 seconds in test conditions or > 30 seconds since last switch while closed loop fuel

HO2S “Over Voltage Test” Operation:	
DTCs	P0132 Over voltage, Bank 1 P0152 Over voltage, Bank 2
Monitor execution	Continuous
Monitor Sequence	None
Sensors OK	front HO2S heaters OK
Monitoring Duration	10 seconds to register a malfunction

Typical HO2S “Over Voltage Test” entry conditions:		
Entry condition	Minimum	Maximum
Inferred Stream 1 HO2S temperature	400 °F	
Battery Voltage	11.0 Volts	18.0 Volts

Typical HO2S “Over Voltage Test” malfunction thresholds:
> 1.1 volts for 10 seconds for over voltage test

The HO2S is also tested functionally. The response rate is evaluated by entering a special 1.5 Hz. square wave, fuel control routine. This routine drives the air/fuel ratio around stoichiometry at a calibratable frequency and magnitude, producing predictable oxygen sensor signal amplitude. A slow sensor will show reduced amplitude. Oxygen sensor signal amplitude below a minimum threshold indicates a slow sensor malfunction. (P0133 Bank 1, P0153 Bank 2). If the calibrated frequency was not obtained while running the test because of excessive purge vapors, etc., the test will be run again until the correct frequency is obtained.

HO2S Response Rate Operation:	
DTCs	P0133 (slow response Bank 1) P0153 (slow response Bank 2)
Monitor execution	once per driving cycle
Monitor Sequence	> 30 seconds time in lack of switch test
Sensors OK	ECT, IAT, MAF, VSS, TP, ETC, FRP, DPFE EGR, VCT, VMV/EVMV, CVS, FTP, CKP, CMP, ignition coils, injectors, no misfire DTCs, no system failures affecting fuel system, no EVAP gross leak failure, no "lack of switching" malfunctions, front HO2S heaters OK no front HO2S over voltage
Monitoring Duration	6 seconds

Typical HO2S response rate entry conditions:		
Entry condition	Minimum	Maximum
Stream 1 HO2S not in CSD recovery mode		
Flex Fuel Composition not changing		
Not in Phase 0 of Evaporative System Monitor		
No Purge System reset		
Purge intrusive test not running		
Not performing CSEER spark retard		
Engine Coolant Temp	150 °F	240 °F
Intake Air Temp		140 °F
Time since entering closed loop fuel	10 seconds	
Inferred Catalyst Midbed Temperature		1600 °F
Fuel Level	15%	
Short Term Fuel Trim Range	-9%	11%
Short Term Fuel Trim Absolute Change while in monitor		10%
Engine Load	20%	50%
Maximum change in engine load while in monitor		0.13
Vehicle Speed	30 mph	80 mph
Maximum change in vehicle speed while in monitor		3 mph
Engine RPM	1000 rpm	2000 rpm
Maximum change in engine rpm while in monitor		150 rpm
Battery Voltage	11.0 Volts	18.0 Volts

Typical HO2Sresponse rate malfunction thresholds:

Voltage amplitude: < 0.5 volts

J1979 Front HO2S Mode \$06 Data

Monitor ID	Test ID	Description for CAN	
\$01	\$80	HO2S11 voltage amplitude and voltage threshold	Volts
\$01	\$01	H02S11 sensor switch-point voltage	Volts
\$05	\$80	HO2S21 voltage amplitude and voltage threshold	Volts
\$05	\$01	H02S21 sensor switch-point voltage	Volts

HO2S Monitor

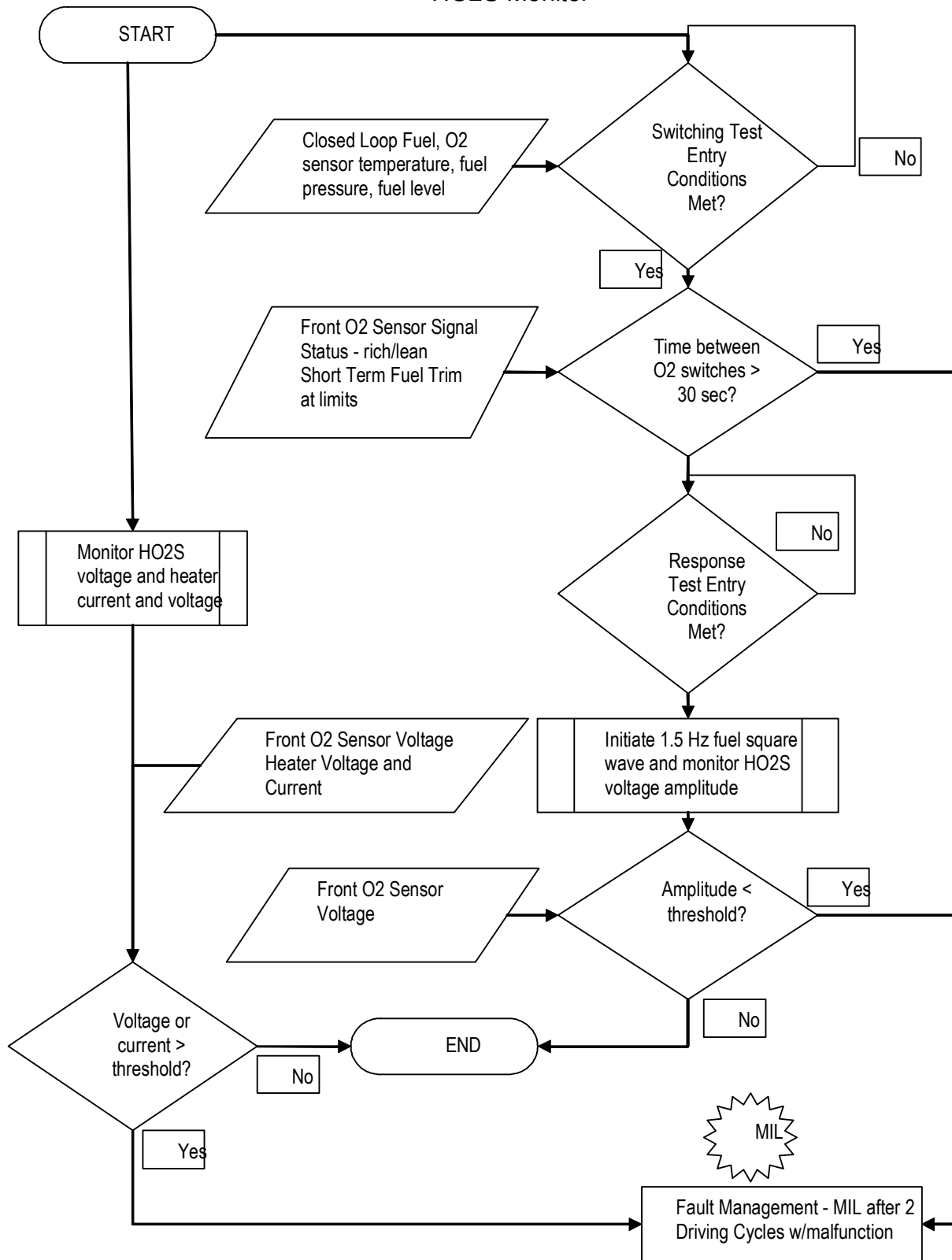

Front HO2S Heaters

The HO2S heaters are monitored for proper voltage and current. A HO2S heater voltage fault is determined by turning the heater on and off and looking for corresponding voltage change in the heater output driver circuit in the PCM.

A separate current-monitoring circuit monitors heater current once per driving cycle. The heater current is actually sampled three times. If the current value for two of the three samples falls below a calibratable threshold, the heater is assumed to be degraded or malfunctioning. (Multiple samples are taken for protection against noise on the heater current circuit.)

HO2S Heater Monitor Operation:	
DTCs Sensor 1	P0135 O2 Heater Circuit, Bank 1 P0155 O2 Heater Circuit, Bank 2 P0053 O2 Heater Resistance, Bank 1 P0059 O2 Heater Resistance, Bank 2
Monitor execution	once per driving cycle for heater current, continuous for voltage monitoring
Monitor Sequence	Heater current monitor: Stream 1 HO2S/UEGO response test complete, Stream 2 and 3 HO2S functional tests complete, HO2S/UEGO heater voltage check complete
Sensors OK	Heater current monitor: no HO2S/UEGO heater voltage DTCs
Monitoring Duration	< 10 seconds for heater voltage check, < 5 seconds for heater current check

Typical HO2S heater monitor entry conditions:		
Entry condition	Minimum	Maximum
Inferred HO2S 1 Temperature (heater voltage check only)	150 °F	1250 °F
Inferred HO2S 1 Temperature (heater current check only)	250 °F	1250 °F
HO2S 1/2/3 heater-on time (heater current check only)	30 seconds	
Engine RPM (heater current check only)		5000 rpm
Battery Voltage (heater voltage check only)	11.0	18.0 Volts

Typical HO2S heater check malfunction thresholds:	
Smart driver status indicated malfunction	
Number monitor retries allowed for malfunction > = 30	
Heater current outside limits:	< 0.220 amps or > 3 amps, (NTK)
	< 0.400 amps or > 3 amps, (Bosch)
	< 0.465 amps or > 3 amps, (NTK Fast Light Off)
	< 0.230 amps or > 3 amps, (Bosch Fast Light Off)

J1979 HO2S Heater Mode \$06 Data

Monitor ID	Test ID	Description for CAN	Units
\$01	\$81	HO2S11 Heater Current	Amps
\$05	\$81	HO2S21 Heater Current	Amps

Front UEGO Monitor

Front UEGO Signal

The UEGO sensor infers an air fuel ratio relative to the stoichiometric (chemically balanced) air fuel ratio by balancing the amount of oxygen pumped in or out of a measurement chamber. As the exhaust gasses get richer or leaner, the amount of oxygen that must be pumped in or out to maintain a stoichiometric air fuel ratio in the measurement chamber varies in proportion to the air fuel ratio. By measuring the current required to pump the oxygen in or out, the air fuel ratio (λ) can be estimated. Note that the measured air fuel ratio is actually the output from the UEGO ASIC pumping current controller and not a signal that comes directly from the sensor.

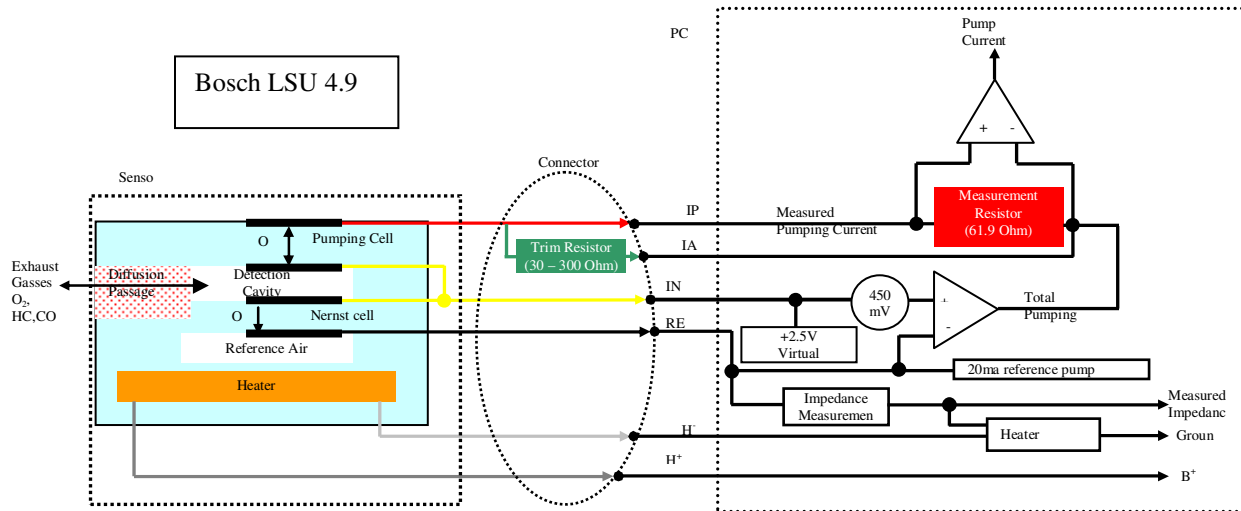

Bosch UEGO sensor interface:

- IP – primary pumping current that flows through the sensing resistor
- IA – current flow through trim resistor in parallel with sense resistor.
- VM – Virtual ground, approximately 2.5 volts above PCM ground.
- RE – Nernst cell voltage, 450mv from VM. Also carries current for pumped reference.
- H+ – Heater voltage – to battery.
- H- – Heater ground side – Duty cycle on/off to control sensor temperature.

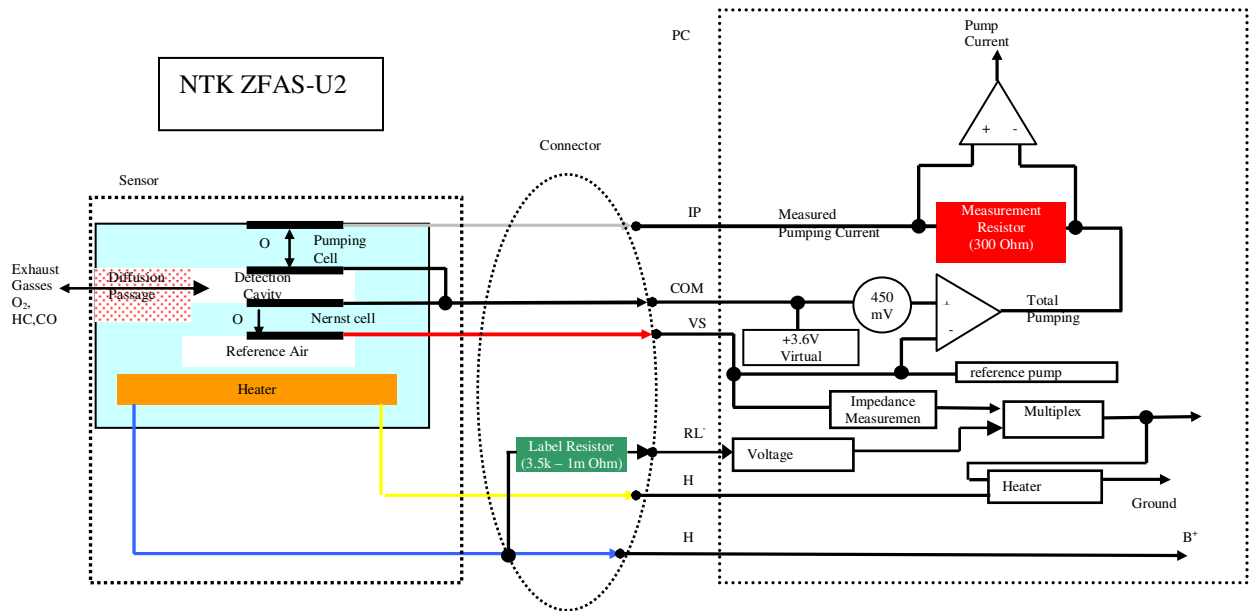

NTK UEGO sensor interface:

IP – primary pumping current that flows through the sensing resistor

COM – Virtual ground, approximately 3.6 volts above PCM ground.

VS – Nernst cell voltage, 450mv from COM. Also carries current for pumped reference.

RL - Voltage input from label resistor.

H+ – Heater voltage – to battery.

H- – Heater ground side – Duty cycle on/off to control sensor temperature.

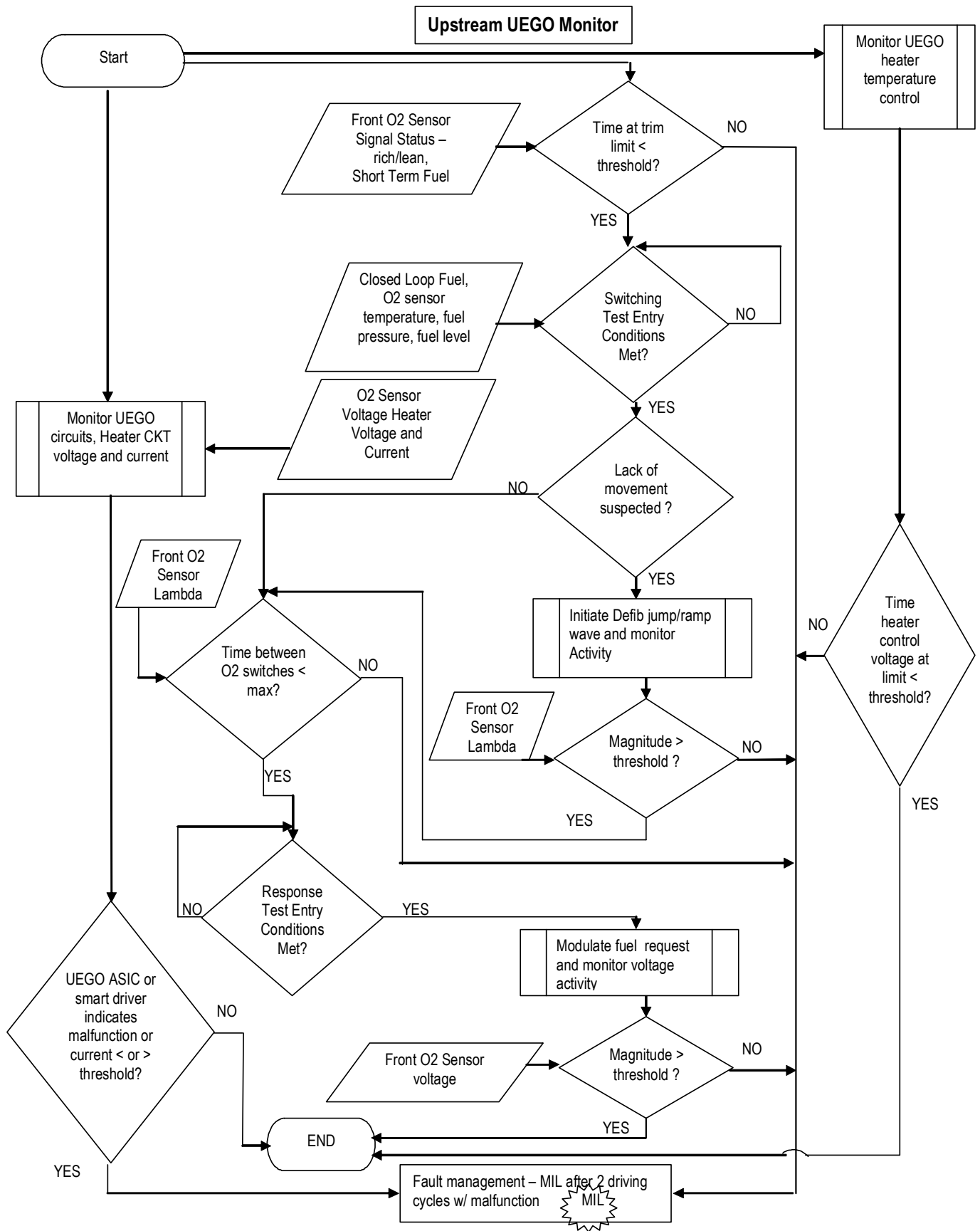

The primary component of a UEGO sensor is the diffusion passage that controls the flow of exhaust gasses into a detection cavity, a Nernst cell (essentially an EGO sensor inside the UEGO sensor) that measures the air fuel ratio in the detection cavity. A control circuitry in the ASIC chip (mounted in the PCM) controls the pumping current (IP) to keep the detection cavity near stoichiometry by holding the Nernst cell at 450 mV. This Nernst cell voltage (RE, VS) is 450mV from the virtual ground (VM, COM), which is approximately 2.5V (Bosch UEGO) or 3.6V (NTK UEGO) above the PCM ground. For the Nernst cell to generate a voltage when the detection cavity is rich, it needs an oxygen differential across the cell. In older UEGO (and HEGO) sensor designs, this was provided by a reference chamber that was connected to outside air through the wire harness that was subject to contamination and "Characteristic Shift Down (CSD)". The new UEGO sensor uses a pumped reference chamber, which is sealed from the outside to eliminate the potential for contamination. The necessary oxygen is supplied by supplying a 20 mA pumping current across the Nernst cell to pump small amounts of oxygen from the detection cavity to the reference chamber. The pumping cell pumps oxygen ions in and out of the detection cavity from and to the exhaust gasses in response to the changes in the Nernst cell voltage. The pumping current flows through the sense resistor and the voltage drop across the sense resistor is measured and amplified. Offset volts are sent out of the ASIC to one of the PCM's A/D inputs. The PCM measures the voltage supplied by the ASIC, determines the pumping current, and converts the pumping current to measured lambda. In general, the circuitry that measures the pumping current is used to estimate the air fuel ratio in the exhaust system.

The UEGO sensor also has a trim (IA) or label resistor (RL). The biggest source of part to part variability in the measured air fuel ratio is difference in the diffusion passage. This source of variation is simply the piece-to-piece differences from the manufacturing process. To compensate for this source of error, each sensor is tested at the factory and a trim or label resistor is installed in the connector. The value of this resistor is chosen to correlate with the measured difference between a particular sensor and a nominal sensor. For NTK UEGO, the variation in the Ip signal value is corrected for by a compensation coefficient (CC), and then processed by the PCM. The value of CC (Ip rank) is determined by the value of RL. The PCM must command the ASIC to read the value of RL, so CC can be determined. After measuring the value of the label resistor, the PCM software will multiply the measured pumping current (Ip) by a compensation coefficient and determine a corrected pumping current that is used to calculate the measured exhaust air fuel ratio. During each power up, the PCM will briefly turn the UEGO heater power off, measure the output voltage from the voltage divider several times, average it, and estimate the resistance of the label resistor. The PCM will do this estimation multiple times, and if all samples are consistently within one resistor "rank", then the RL compensation coefficient determination is completed and the resistor "rank" compensation coefficient value will be stored in keep alive memory. On the other hand, if the several readings are not consistently within one rank for some amount of time, then the PCM A/D input is considered not reliable/RL erratic, and a trim circuit erratic malfunction (P164A, P164B) will be set. Conversely, if the estimated resistance is too high, then the software in the PCM will indicate RL circuit shorted to ground or open, and a trim circuit low malfunction (P2627, P2630) will be set. If the estimated resistance is too low, then the software will indicate RL circuit shorted to power, and a trim circuit high malfunction (P2628, P2631) will be set. Once a trim circuit malfunction is detected, then the compensation coefficient of the label resistor "rank" stored in KAM will be used.

The time spent at the limits of the short term fuel trim and the time when the measured lambda is nearly 1.0 are monitored after vehicle startup when closed loop fuel has been requested, during closed loop fuel conditions, or when open loop fuel has been requested due to UEGO sensor fault. Excessive time with short term fuel trim at its limits (up to +/- 40%), or no rich / lean activity seen since startup indicates a "lack of switch" malfunction. Also, excessive time without measured lambda deviating from 1.0, in spite of attempts to force activity (defib) in the measured lambda, indicates a "lack of movement" malfunction. Since "lack of switching" malfunctions can be caused by UEGO sensor malfunctions or by shifts in the fuel system, DTCs are stored that provide additional information for the "lack of switching" malfunction. Different DTCs indicate whether the sensor always indicates lean (P2195, P2197), or always indicates rich (P2196, P2198). "Lack of movement" malfunction, (Bosch UEGO application only), typically indicating a disconnected wire (pumping current, IP), results in P0134, P0154 DTCs.

UEGO equipped vehicles will also monitor the circuitry between the PCM and the UEGO sensor via the wire diagnostics capability included on the UEGO ASIC chip. The wire diagnostics will detect wires (IP, IA, VM/COM, RE/VS) shorted to battery, or ground, and in most cases will detect open circuits (IP, VM/COM, RE/VS). The diagnostic bits are transmitted to the PCM via SPI (serial peripheral interface). The SPI communication is validated continuously, and if a SPI communication failure is detected, fault code(s) P064D and/or P064E will be set. The ASIC is also capable of detecting internal circuitry failure; in which case, an ASIC failure DTC (P1646, P1647) along with the SPI communication failure DTC (P064D, P064E) will be set.

UEGO "Lack of Switching" Operation:	
DTCs	P2195 - Lack of switching, sensor indicates lean, Bank 1 P2196 - Lack of switching, sensor indicates rich, Bank 1 P2197 - Lack of switching, sensor indicates lean, Bank 2 P2198 - Lack of switching, sensor indicates rich, Bank 2
Monitor execution	continuous, from startup and while in closed loop fuel or open loop fuel due to UEGO sensor fault
Monitor Sequence	None
Sensors OK	ECT, IAT, MAF, VSS, TP, ETC, FRP, DPFE EGR, VCT, VMV/EVMV, CVS, FTP, CKP, CMP, ignition coils, injectors, no misfire DTCs, no system failures affecting fuel, no EVAP gross leak failure, UEGO heaters OK, no "lack of movement" malfunction, no UEGO circuit malfunction
Monitoring Duration	30 seconds to register a malfunction

Typical UEGO "Lack of Switching" entry conditions:		
Entry condition	Minimum	Maximum
Closed Loop or Open Loop Requested due to UEGO sensor fault		
No fuel flow entering thru PCV during cold start when flashing off fuel in oil (for O2 Sensor Stuck Rich DTCs only)		
Inferred Ambient Temperature	-40 °F	
Time within entry conditions	10 seconds	
Fuel Tank Pressure		10 in H ₂ O
Fuel Level	15%	
Battery Voltage	11.0 Volts	18.0 Volts

Typical UEGO "Lack of Switching" malfunction thresholds:
> 30 seconds since reaching the short term fuel trim limits while closed loop fuel or < 0.5 seconds rich or < 0.5 seconds lean since startup for > 30 seconds in test conditions while open loop fuel is requested due to UEGO sensor fault.

UEGO "Lack of Movement" Operation:	
DTCs	P0134 - Lack of movement, Bank 1 P0154 – Lack of movement, Bank 2
Monitor execution	continuous, from startup and while in closed loop fuel or open loop fuel due to UEGO sensor fault
Monitor Sequence	None
Sensors OK	ignition coils, injectors, no misfire DTCs, no system failures affecting fuel, UEGO heaters OK, no "lack of switching" malfunction, no UEGO circuit malfunction
Monitoring Duration	20 seconds to register a malfunction

Typical UEGO "Lack of Movement" entry conditions:		
Entry condition	Minimum	Maximum
Closed Loop or Open Loop Requested due to UEGO sensor fault		
Inferred Ambient Temperature	-40 °F	
Battery Voltage	11.0 Volts	18.0 Volts

Typical UEGO "Lack of Movement" malfunction thresholds:
> 20 seconds in test conditions without lambda movement during "defib" while in closed loop fuel or < 0.2 seconds without lambda movement since startup for > 30 seconds in test conditions while open loop fuel is requested due to UEGO sensor fault.

UEGO "Wire Diagnostic" Operation:

DTCs	<p>P0130 – O2 circuit (Bank 1, Sensor 1). Note: This DTC will set for open IP (NTK), RE/VS, VM/COM, short to ground IP (Bosch), RE, VM, IA, short to battery IP (Bosch), RE, VM, IA.</p> <p>P0150 – O2 circuit (Bank 2, Sensor 1). Note: This DTC will set for open IP (NTK), RE/VS, VM/COM, short to ground IP (Bosch), RE, VM, IA, short to battery IP (Bosch), RE, VM, IA.</p> <p>P0131 – O2 circuit low voltage (Bank 1, Sensor 1). Note: This DTC will set for short to ground IP (NTK), VS, COM.</p> <p>P0151 – O2 circuit low voltage (Bank 2, Sensor 1). Note: This DTC will set for short to ground IP (NTK), VS, COM.</p> <p>P0132 – O2 circuit high voltage (Bank 1, Sensor 1). Note: This DTC will set for short to battery IP (NTK), VS, COM.</p> <p>P0152 – O2 circuit high voltage (Bank 2, Sensor 1). Note: This DTC will set for short to battery IP (NTK), VS, COM.</p> <p>P164A – O2 sensor positive current trim circuit performance (Bank 1, Sensor 1). Note: This DTC will set for an erratic RL.</p> <p>P164B – O2 sensor positive current trim circuit performance (Bank 2, Sensor 1). Note: This DTC will set for an erratic RL.</p> <p>P2627 – O2 sensor positive current trim circuit low (Bank 1, Sensor 1). Note: This DTC will set for open or short to ground RL.</p> <p>P2630 – O2 sensor positive current trim circuit low (Bank 2, Sensor 1). Note: This DTC will set for open or short to ground RL.</p> <p>P2628 – O2 sensor positive current trim circuit high (Bank 1, Sensor 1). Note: This DTC will set for short to battery RL.</p> <p>P2631 – O2 sensor positive current trim circuit high (Bank 2, Sensor 1). Note: This DTC will set for open or short to battery RL.</p> <p>P1646 – Linear O2 sensor control chip, Bank 1 P1647 – Linear O2 sensor control chip, Bank 2 P064D – Internal control module O2 sensor processor performance (Bank 1) P064E – Internal control module O2 sensor processor performance (Bank 2)</p>
Monitor execution	continuous
Monitor Sequence	None
Sensors OK	UEGO heaters OK
Monitoring Duration	10 seconds to register a malfunction

Typical UEGO "Wire Diagnostic" entry conditions:

Entry condition	Minimum	Maximum
Fault reported by UEGO ASIC		
Battery Voltage	11.0 Volts	18.0 Volts

Typical UEGO "Wire Diagnostic" malfunction thresholds:

UEGO ASIC indicated malfunction

> 10 seconds to set a code when circuit failure is present.

The UEGO is also tested functionally. The response rate is evaluated by entering a special 0.5Hz-1.5 Hz. square wave, fuel control routine. This routine drives the air/fuel ratio around stoichiometry at a calibratable frequency and magnitude, producing predictable oxygen sensor signal amplitude. A slow sensor will show reduced amplitude, measured as a line length. Oxygen sensor signal line length below a minimum threshold indicates a slow sensor malfunction (P0133 Bank 1, P0153 Bank 2). If the calibrated frequency was not obtained while running the test because of excessive purge vapors, etc., the test will be run again until the correct frequency is obtained.

UEGO "Response Rate" Operation:	
DTCs	P0133 (slow response Bank 1), P0153 (slow response Bank 2)
Monitor execution	once per driving cycle
Monitor Sequence	> 30 seconds time in lack of movement test, > 30 seconds time in lack of switch test,
Sensors OK	ECT, IAT, MAF, VSS, TP, ETC, FRP, DPFE EGR, VCT, VMV/EVMV, CVS, FTP, CKP, CMP, ignition coils, injectors, no misfire DTCs, no system failures affecting fuel, no EVAP gross leak failure, UEGO heaters OK, no "lack of switching" malfunction, no "lack of movement" malfunction, no UEGO circuit malfunction, no UEGO FAOS monitor malfunction
Monitoring Duration	4-12 seconds

Typical UEGO "Response Rate" entry conditions:		
Entry condition	Minimum	Maximum
Flex Fuel Composition not changing		
Not in Phase 0 of Evaporative System Monitor		
No Purge System reset		
Purge intrusive test not running		
Not performing CSER spark retard		
Engine Coolant Temp	150 °F	240 °F
Intake Air Temp		140 °F
Time since entering closed loop fuel	10 seconds	
Inferred Catalyst Midbed Temperature		1600 °F
Fuel Level	15%	
Short Term Fuel Trim Range	-5%	5%
Short Term Fuel Trim Absolute Change while in monitor		15%
Engine Load	20%	70%
Maximum change in engine load while in monitor		0.25
Vehicle Speed	35 mph	80 mph
Maximum change in vehicle speed while in monitor		3 mph
Engine RPM	1000 rpm	3000 rpm
Maximum change in engine rpm while in monitor		150 rpm
Commanded versus actual lambda range while in monitor	0.85	1.15
Air mass stability criteria met while in monitor		
Battery Voltage	11.0 Volts	18.0 Volts

Typical UEGO "Response Rate" malfunction thresholds:

Line length (Voltage amplitude): < 15 units

J1979 Front UEGO Mode \$06 Data

Monitor ID	Test ID	Description for CAN	
\$01	\$84	UEGO11 voltage length	unitless
\$05	\$84	UEGO21 voltage length	unitless

FAOSC (Rear Fuel Trim) Monitor

As the front UEGO sensor ages and gets exposed to contaminants, it can develop a rich or lean bias in its transfer function. The rear bias control (also called FAOSC – Fore/Aft Oxygen Sensor Control) system is designed to compensate for any of these bias shifts (offsets) using the downstream HO2S sensor. The "FAOS" monitor looks for any bias shifts at the stoichiometric point of the front UEGO sensor lambda curve. If the UEGO has developed a bias beyond the point for which it can be compensated for, lean (P2096, P2098) or rich (P2097, P2099) fault codes will be set.

UEGO "FAOS Monitor" Operation:	
DTCs	P2096 – Post catalyst fuel trim system too lean (Bank 1) P2097 – Post catalyst fuel trim system too rich (Bank 1) P2098 – Post catalyst fuel trim system too lean (Bank 2) P2099 – Post catalyst fuel trim system too rich (Bank 2)
Monitor execution	Continuous while in closed loop fuel
Monitor Sequence	> 30 seconds time in lack of movement test, > 30 seconds time in lack of switch test
Sensors OK	ECT, IAT, MAF, VSS, TP, ETC, FRP, DPFE EGR, VCT, VMV/EVMV, CVS, FTP, CKP, CMP, ignition coils, injectors, no misfire DTCs, no system failures affecting fuel, no EVAP gross leak failure, UEGO heaters OK, rear HO2S heaters OK, no "lack of switching" malfunction, no "lack of movement" malfunction, no UEGO circuit malfunction, no rear stream 2 HO2S circuit malfunction, no rear stream 2 HO2S functional DTCs, no rear stream 2 HO2S response rate malfunction.
Monitoring Duration	5 seconds to register a malfunction

Typical UEGO "FAOS Monitor" entry conditions:		
Entry condition	Minimum	Maximum
Engine Coolant Temp	170 °F	234 °F
Time since entering closed loop fuel	5 seconds	
Fuel Level	15%	
Short Term Fuel Trim Range	-13%	18%
Short Term Fuel Trim Absolute Change		10%
Air mass change for transient rejection		2 lbm/min
Learning conditions stability time (based on air mass)	15 seconds	
Stream1 UEGO response test not running		
Intrusive UEGO catalyst monitor not running		
Battery Voltage	11.0 Volts	18.0 Volts

Typical UEGO "FAOS Monitor" malfunction thresholds:
>= 5 seconds since reaching the FAOSC lean or rich limits while system bias maturity is met.

UEGO Heaters

The UEGO heater is controlled as a function of the measured impedance to keep the sensor at a near constant temperature (Bosch: 780 deg C, NTK: 800 deg C). The impedance of the Nernst cell decreases as the sensor temperature increases. This impedance is measured by periodically applying a small current across the Nernst cell and measuring the change in the voltage. The output voltage is then sent to an A/D input on the PCM. After a cold start, the UEGO heater ramps up to the maximum duty cycle to heat the sensor. After a few seconds, the measured impedance will start to decrease and when the target value is crossed, the heater goes into closed loop heater control to maintain the sensor at a near constant temperature.

The "UEGO Heater Temperature Control Monitor" tracks the time at the maximum duty cycle during the open loop sensor warm up phase. If the measured impedance does not come down to the target value to allow the system to transition from open loop heater control to closed loop heater control within a specified time, then a fault code is set. This monitor also sets a malfunction when the closed loop heater control reaches a maximum or minimum value for a period of time indicating that the controller is no longer able to maintain the target temperature, however, if the inferred exhaust temperature is high enough that the sensor will be above the target temperature even with no heat, then this monitor is disabled.

The UEGO heaters are also monitored for proper voltage and current. A UEGO heater voltage fault is determined by turning the heater on and off and looking for corresponding voltage change in the heater output driver circuit in the PCM.

A separate current-monitoring circuit monitors heater current once per driving cycle. This monitor normally runs in closed loop heater control after all the exhaust gas sensor functional tests are completed, however, it can also run intrusively. When the UEGO sensor indicates cold, but the heater is inferred to have been adequately warm, the current monitor is forced to run intrusively prior to the completion of the heater temperature control monitor. The heater current is actually sampled three times. If the current value for two of the three samples falls below or above a calibratable threshold, the heater is assumed to be degraded or malfunctioning. (Multiple samples are taken for protection against noise on the heater current circuit.)

UEGO Heater Monitor Operation:	
DTCs	P0030 Heater Temperature Control Failure, Bank 1 P0050 Heater Temperature Control Failure, Bank 2 P0135 O2 Heater Circuit, Bank 1 P0155 O2 Heater Circuit, Bank 2 P0053 O2 Heater Resistance, Bank 1 P0059 O2 Heater Resistance, Bank 2
Monitor execution	once per driving cycle for heater current monitor, continuous for voltage monitoring and heater temperature control monitoring
Monitor Sequence	Heater current monitor: Stream 1 UEGO response test complete, Stream 2 and 3 HO2S functional tests complete, Stream 1 UEGO heater voltage check complete. Heater temperature control monitor: intrusive heater current monitor completed.
Sensors OK	Heater current monitor: no HO2S/UEGO heater circuit malfunction, Heater temperature control monitor: no UEGO circuit malfunction, no UEGO heater circuit malfunction, no UEGO heater current monitor DTCs.
Monitoring Duration	< 10 seconds for heater voltage check, < 5 seconds for heater current check, >= 30 seconds for the heater temperature control monitor to register a malfunction

Typical UEGO heater monitor entry conditions:		
Entry condition	Minimum	Maximum
Inferred UEGO unheated tip temperature (heater voltage check only)	75 °F	1562 °F
Inferred UEGO heated tip temperature (heater current check only)	1346 °F	1526 °F
UEGO heater-on time (heater current check only)	30 seconds	
Engine RPM (heater current check only)		5000 rpm
Inferred UEGO unheated tip temperature (heater control monitor only)	75 °F	1000 °F
Battery Voltage	11.0 Volts	18.0 Volts

Typical UEGO heater check malfunction thresholds:
Smart driver status indicated malfunction (heater voltage check)
Number monitor retries allowed for malfunction > = 30 (heater voltage check)
Heater current outside limits:
< 1.0 amps or > 3 amps (intrusive test) or < 0.55 amps or > 3 amps (Bosch UEGO)
< 1.5 amps or > 3 amps (intrusive test) or < 1.24 amps or > 3 amps (NTK UEGO)
Heater temperature control monitor: > = 30 seconds to register a malfunction while the heater control integrator is at its maximum or minimum limit

J1979 UEGO Heater Mode \$06 Data			
Monitor ID	Test ID	Description for CAN	Units
\$01	\$81	HO2S11 Heater Current	Amps
\$05	\$81	HO2S21 Heater Current	Amps

Rear HO2S Monitor

Rear HO2S Signal

A functional test of the rear HO2S sensors is done during normal vehicle operation. The peak rich and lean voltages are continuously monitored. Voltages that exceed the calibratable rich and lean thresholds indicate a functional sensor. If the voltages have not exceeded the thresholds after a long period of vehicle operation, the air/fuel ratio may be forced rich or lean in an attempt to get the rear sensor to switch. This situation normally occurs only with a green catalyst (< 500 miles). If the sensor does not exceed the rich and lean peak thresholds, a malfunction is indicated.

2005 MY and beyond vehicles will monitor the rear HO2S signal for high voltage, in excess of 1.1 volts and store a unique DTC. (P0138, P0158). An over voltage condition is caused by a HO2S heater or battery power short to the HO2S signal line.

Some Partial Zero Emission Vehicles (PZEV Focus) may utilize three sets of HO2S sensors. The front sensors (HO2S11/HO2S21) are the primary fuel control sensors. The next sensors downstream in the exhaust are utilized to monitor the light-off catalyst (HO2S12/HO2S22). The last sensors downstream in the exhaust (HO2S13/HO2S23) are utilized for very long term fuel trim in order to optimize catalyst efficiency (Fore Aft Oxygen Sensor Control). Ford's first PZEV vehicle uses a 4-cylinder engine so only the Bank 1 DTCs are utilized.

Rear HO2S Functional Check Operation:	
DTCs Sensor 2	P0136 HO2S12 No activity or P2270 HO2S12 Signal Stuck Lean P2271 HO2S12 Signal Stuck Rich P0156 HO2S22 No activity or P2272 HO2S22 Signal Stuck Lean P2273 HO2S22 Signal Stuck Rich
DTCs Sensor 3	P2274 HO2S13 Signal Stuck Lean P2275 HO2S13 Signal Stuck Rich P2276 HO2S23 Signal Stuck Lean P2277 HO2S23 Signal Stuck Rich
Monitor execution	once per driving cycle for activity test
Monitor Sequence	> 30 seconds time in lack of movement test (UEGO only), > 30 seconds time in lack of switch test, front HO2S/UEGO response test complete
Sensors OK	ECT, IAT, MAF, VSS, TP, ETC, FRP, DPFE EGR, VCT, VMV/EVMV, CVS, FTP, CKP, CMP, ignition coils, injectors, no misfire DTCs, no system failures affecting fuel, no EVAP gross leak failure, UEGO/HO2S (front and rear) heaters OK, no "lack of switching" malfunction, no "lack of movement" malfunction (UEGO only), no UEGO/HO2S (front and rear) circuit malfunction, no UEGO FAOS monitor malfunction, no front HO2S/UEGO response rate malfunction
Monitoring Duration	continuous until monitor completed

Typical Rear HO2S functional check entry conditions:

Entry condition	Minimum	Maximum
Stream 1 HO2S not in CSD recovery mode		
Flex Fuel Composition not changing		
Not in Phase 0 of Evaporative System Monitor		
No Purge System reset		
Purge intrusive test not running		
Not performing CSER spark retard		
Engine Coolant Temp	150 °F	240 °F
Intake Air Temp		140 °F
Time since entering closed loop fuel	10 seconds	
Inferred Catalyst Midbed Temperature		1600 °F
Heater-on Inferred Sensor(s) 2/3 HO2S Temperature Range	400 °F	1400 °F
Sensor(s) 2/3 HO2S heater-on time	90 seconds	
Short Term Fuel Trim Range	-9%	11%
Fuel Level (forced excursion only)	15%	
Inferred exhaust temperature range	400 °F	1400 °F
Throttle position	Part throttle	
Engine RPM (forced excursion only)	1000 rpm	2000 rpm
Battery Voltage	11.0 Volts	18.0 Volts

Typical Rear HO2S functional check malfunction thresholds:

Does not exceed rich and lean threshold envelope:

Rich < 0.42 volts

Lean > 0.48 volts

J1979 Rear HO2S Functional Check Mode \$06 Data

Monitor ID	Test ID	Description for CAN	
\$02	\$01	HO2S12 sensor switch-point voltage	volts
\$06	\$01	HO2S22 sensor switch-point voltage	volts
\$03	\$01	HO2S13 sensor switch-point voltage	volts
\$07	\$01	HO2S23 sensor switch-point voltage	volts

Rear HO2S “Over Voltage Test” Operation:

DTCs	P0138 HO2S12 Over voltage P0158 HO2S22 Over voltage P0144 HO2S13 Over voltage P0164 HO2S23 Over voltage
Monitor execution	continuous
Monitor Sequence	None
Sensors OK	rear HO2S heaters OK
Monitoring Duration	10 seconds to register a malfunction

Typical HO2S “Over Voltage Test” entry conditions:

Entry condition	Minimum	Maximum
Inferred Stream 2/3 HO2S Temperature	400 °F	
Battery Voltage	11.0 Volts	18.0 Volts

Typical HO2S “Over Voltage Test” malfunction thresholds:

> 1.1 volts for 10 seconds for over voltage test

Rear HO2S Passive Response Test

Starting with the 2007 MY, the rear/downstream HO2S is also tested for proper response. A two stage test performed once per driving cycle. First, a passive test is performed. If the passive test "passes", the rear HO2S response monitor is complete. If the passive test does not complete in time, the monitor proceeds to the active test.

Passive Test Overview:

- The diagnostic monitors the voltage slew rate during a passive rear O2 sensor "switch" to determine if the sensor has slowed down.
- The sensor slew rate is tracked continuously during normal vehicle operation
- The monitor will complete if a rear sensor switch of sufficient voltage magnitude is detected in the rich to lean and lean to rich directions and the sensor slew rate is above a calibrated value.
- If the front sensor response rate test has completed, but there has not been sufficient rear sensor activity (i.e. sensor slew rate is slow), an intrusive mode will be entered.

Active Test Overview:

- The intrusive mode test involves inducing an air fuel modulation at slowly increasing magnitudes.
- The sensor will pass the diagnostic if sufficiently fast switches are seen.
- The sensor will fail the diagnostic if:
 - the modulation has reached its limits by calibrated number of events, or
 - the time in intrusive mode has exceeded and high slew rate switches were still not detected

Slew rate is calculated from the delta voltage and delta time between the last sample before crossing the 0.6 volt threshold and the first sample after crossing the 0.3 volt threshold. Slew rates are tracked as a function of bank and direction. Threshold voltages can be calibrated differently for each direction. Minimum slew rate required to pass is calibrated differently for each direction.

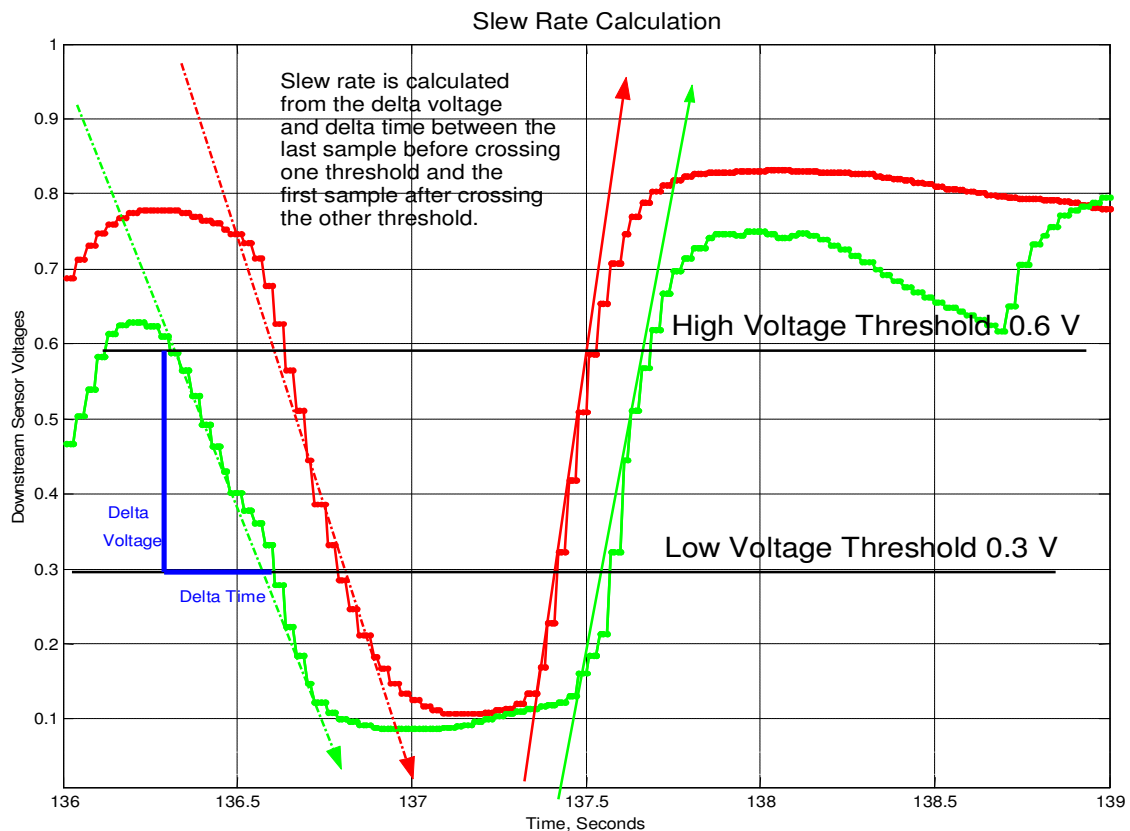

Rear HO2S Response Rate Operation:	
DTCs	P0139 (slow response Bank 1), P0159 (slow response Bank 2)
Monitor execution	once per driving cycle
Monitor Sequence	> 30 seconds time in lack of movement test (UEGO only), > 30 seconds time in lack of switch test, front HO2S/UEGO response test complete, HO2S 2 and 3 functional tests complete, HO2S/UEGO heater voltage and current checks complete, FAOS monitor system bias maturity met (UEGO applications only)
Sensors OK	ECT, IAT, MAF, VSS, TP, ETC, FRP, DPFE EGR, VCT, VMV/EVMV, CVS, FTP, CKP, CMP, ignition coils, injectors, no misfire DTCs, no system failures affecting fuel, no EVAP gross leak failure, UEGO/HO2S (front and rear) heaters OK, no "lack of switching" malfunction, no "lack of movement" malfunction (UEGO only), no UEGO/HO2S (front and rear) circuit malfunction, no UEGO FAOS monitor malfunction, no front HO2S/UEGO response rate malfunction, no rear HO2S functional DTCs.
Monitoring Duration	100 seconds or 50 lean/rich and rich/lean commanded modulations to register a malfunction

Typical Rear HO2S response rate entry conditions:		
Entry condition	Minimum	Maximum
Stream 1 HO2S not in CSD recovery mode		
Flex Fuel Composition not changing		
Not in Phase 0 of Evaporative System Monitor		
No Purge System reset		
Purge intrusive test not running		
Not performing CSER spark retard		
Engine Coolant Temperature	150 °F	240 °F
Intake Air Temperature		140 °F
Time since entering closed loop fuel	10 seconds	
Inferred Catalyst Temperature		1600 °F
Inferred HO2S 2/3 Temperature	400 °F	1400 °F
HO2S 2/3 heater-on time	90 seconds	
Fuel Level (forced excursion only)	15%	
Short Term Fuel Trim Range (forced excursion only)	-9%	11%
Short Term Fuel Trim absolute change (forced excursion only)		10%
Vehicle Speed (forced excursion only)	30 mph	80 mph
Engine RPM (forced excursion only)	1000 rpm	2000 rpm
Time since engine start (forced excursion only)	0 seconds	
Inferred HO2S 2 Temperature (forced excursion only)	1200 °F	
Air Mass Range (forced excursion only)	1.7 lbs/min	7 lbs/min
Abort time if air mass is out of range (forced excursion only)	1 second	
Battery Voltage	11.0 Volts	18.0 Volts

Typical Rear HO2S response rate malfunction thresholds:

Rich to lean slew rate thresholds: = <1.25 mV volts/msec (NTK Thimble)
= < 1.0 mV/msec (Bosch Thimble)
= < 0.75 mV/msec (Bosch Planar)

Lean to rich slew rate thresholds: = < 1.67 mV/msec (NTK Thimble)
= < 1.0 mV/msec (Bosch Thimble)
= < 1.5 mV/msec (Bosch Planar)

J1979 Rear HO2S response rate Mode \$06 Data

Monitor ID	Test ID	Description for CAN	
\$02	\$82	HO2S12 sensor Lean to Rich Response Rate	Volts/msec
\$02	\$83	HO2S12 sensor Rich to Lean Response Rate	Volts/msec
\$06	\$82	HO2S22 sensor Lean to Rich Response Rate	Volts/msec
\$06	\$83	HO2S22 sensor Rich to Lean Response Rate	Volts/msec

Rear HO2S Decel Fuel Shut Off Response Test

The catalyst monitor tracks and uses the length of the rear HO2S signal. The rear HO2S is also known as the Catalyst Monitor Sensor (CMS). As the catalyst ages, air/fuel fluctuations begin to break through the catalyst and the length of this signal increases. Eventually the length of the CMS signal becomes long enough to identify a failure for the catalyst monitor.

When an HO2S sensor degrades, its response to air/fuel fluctuations slows down. The effect of a slow rear HO2S sensor on the catalyst monitor is to reduce the length of the signal. A slow CMS sensor, therefore, may cause the catalyst monitor to incorrectly pass a failed catalyst. The purpose of the Rear DFSO Response diagnostic is to ensure the catalyst monitor has a valid CMS sensor with which to perform the catalyst monitor diagnostic. The monitor is set to trigger at the level of degradation that will cause the catalyst monitor to falsely pass a malfunction threshold catalyst.

The OBD-II regulations require this monitor to utilize Decel Fuel Shut Off (DFSO). Ford plans to aggressively use DFSO starting in the 2009 MY on many applications to improve fuel economy. The DFSO rear O2 response test will be phased in coincident with this feature.

The main part of the test is the measured rich to lean response rate. It is determined by a "slew" rate calculation which determines the rich to lean slope of the sensor during a Decel Fuel Shut Off (DFSO) event which occurs during closed pedal at vehicle speeds higher than 28 mph. The calculation for the slew rate (mV/sec) is illustrated below.

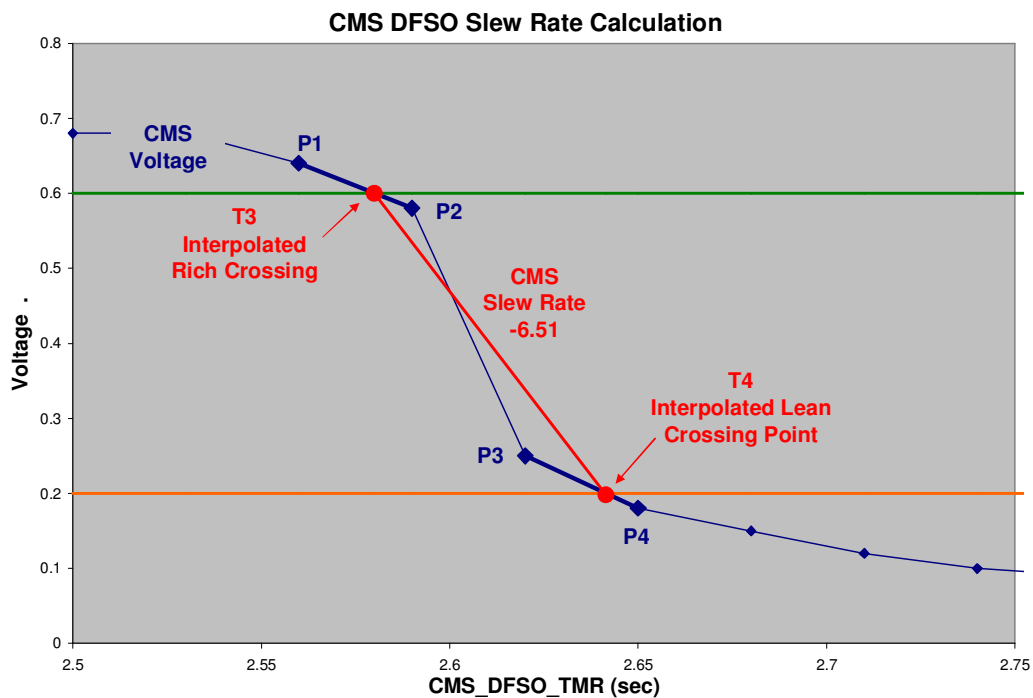

Linear interpolation is performed to calculate the Slew Rate.

1. Interpolate between points P1 and P2 to determine the time at which the rich limit threshold of 0.6 volts was crossed.
2. Interpolate between points P3 and P4 to determine the time at which the lean limit threshold of 0.2 volts was crossed.
3. Use the Interpolated times and the thresholds to calculate the slope or "slew rate" of the CMS sensor from 0.6 to 0.2 volts.

Diagnostic Data Acquisition Event Plot is a schematic of what happens when the pedal is closed and the engine enters DFSO.

CMS DFSO Diagnostic Event Plot

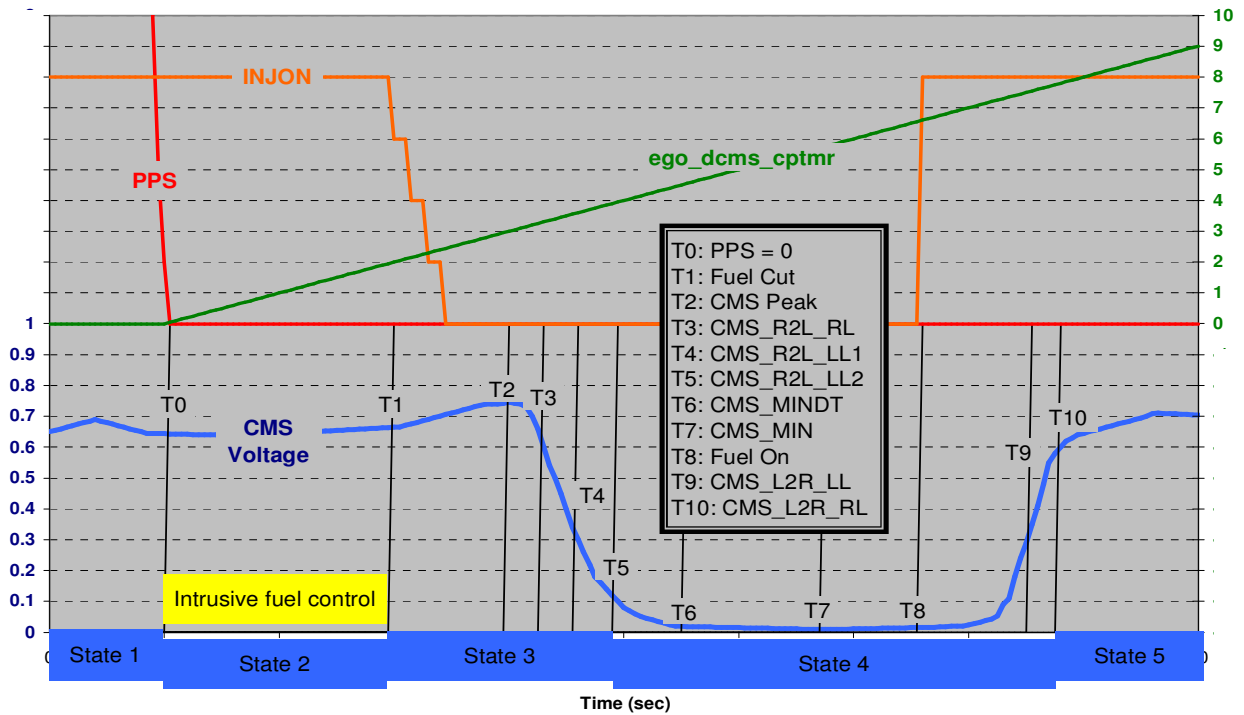

The top half of the graph shows the following signals:

Closed pedal timer (ego_dcms_cptmr).

PPS (Pedal Position Sensor)

INJON (# of fuel injectors turned on)

The bottom half of the graph shows a CMS signal with black lines and a "Tx" number representing all of the points of interest where the monitor captures data.

The monitor measures the CMS Rich to Lean slew rate during a DFSSO event. The CMS voltage must be rich prior to the injector cut for a valid measurement event. Each fuel cut can only yield 1 valid event. The monitor will complete after 3 valid events. Additional valid event results will be stored and applied over the next drive cycle if necessary for monitor completion.

The slope or slew rate of the CMS sensor going from rich to lean is a negative number with the units of mVolts/sec. The measured slew rate changes as an O2 sensor degrades, but it will also change as a function of catalyst oxygen storage/age; therefore, the slew rate is normalized using an offset based on catalyst oxygen storage/age. The catalyst oxygen storage/age is calculated by integrating the level of oxygen mass in the exhaust stream from the time the injectors turn off to the time where the slew rate calculation begins. The fault line (red line in the chart below) is calibrated to 80% of the fault distribution for various levels of oxygen storage/catalyst age. As shown below, the integrated oxygen mass becomes smaller with catalyst age.

The final output of the monitor = the measured slew rate – normalized fault line, therefore, any positive number will represent a fault. For the step change logic the fault threshold will represent 50% of the failed distribution (~ 0.3).

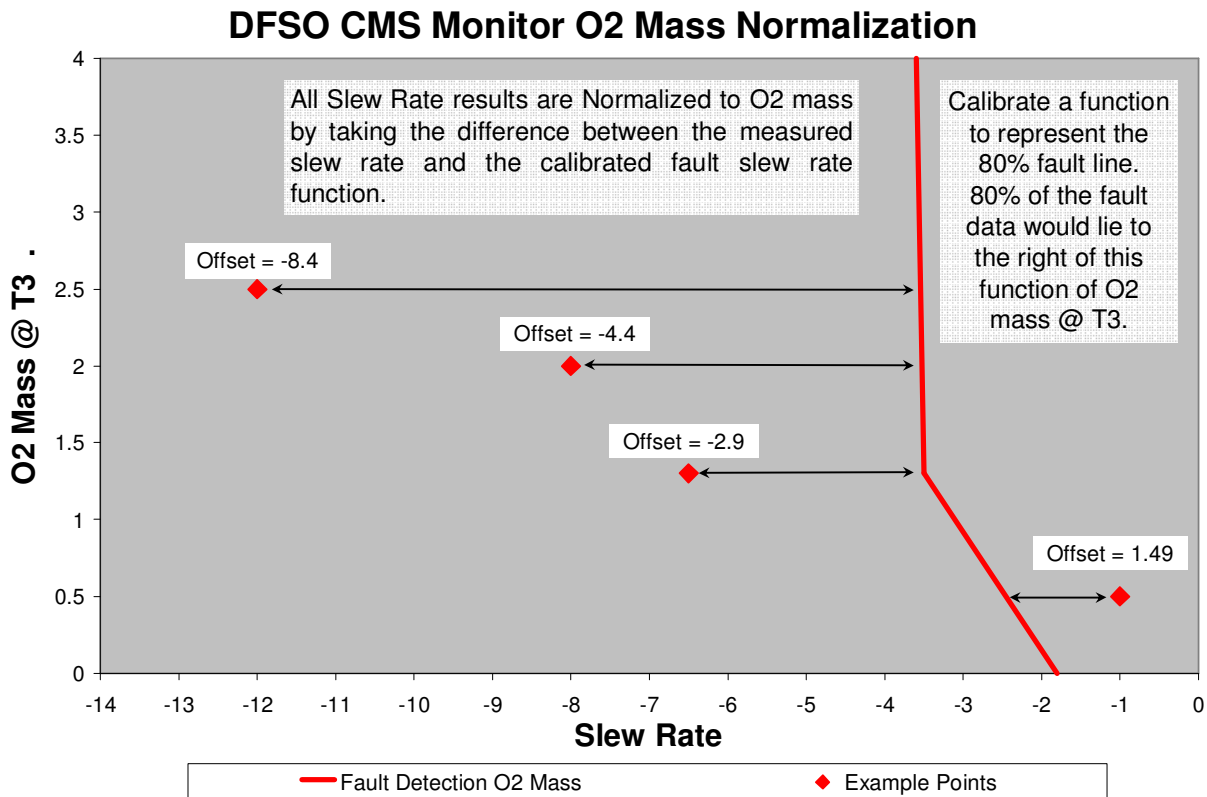

The delayed response part of the test indicates that the sensor is stuck in range. The code sets if the sensor can't get above a calibrated rich or lean voltage prior to a calibrated time out period. This time out must happen three times in a row to set the fault. If it happens once or twice and then the response monitor completes, the counter will be reset and the sensor will have to fail 3 times in a row to again set the DTC.

Due to the fact that intrusively driving the CMS sensor rich will cause drivability and emission concerns, there are other several condition counters that have to fail prior to intrusively forcing the sensor to go rich. The sequence of events to get to the rich failure is shown below:

- Initially, in order to avoid excess emissions, the monitor will only run if the CMS voltage is rich (> 0.6 volts) or CMS sensor is transitioning from lean to rich (large positive slope . 0.2).
 - Successive failures are counted up; when the count exceeds 5 to 10 failures the monitor will now intrusively force rich fuel to run the test.
- In order to avoid a drivability issues as a result of a lean shifted bank, the first phase of intrusive control has a short time out (1 to 2 seconds).
 - Successive failures are counted up; when the count exceeds 3 failures the monitor will now intrusively force rich fuel to failure or a rich sensor.
- All controllable measures have failed to force the sensor to switch, so the strategy will drive rich until the sensor switches or the failure time out is exceeded (5 to 10 seconds).
 - Successive failures are counted up; when the count exceeds 3 failures the monitor will now set a fault (P013E for bank 1 or P014A for bank 2).

If the sensor is stuck rich (can't get lean) the fault procedure is:

- While the injectors remain off, the sensor must get lean (<0.1 volts) prior to the failure time which must be set to account for a green catalyst (5 to 10 seconds).
 - Successive failures are counted up; when the count exceeds 3 failures the monitor will now set a fault (P013E for bank 1 or P014A for bank 2).

EWMA Fault Filtering

The EWMA logic incorporates several important CARB requirements. These are:

- Fast Initial Response (FIR): The first 4 tests after a battery disconnect or code clear will process unfiltered data to quickly indicate a fault. The FIR will use a 2-trip MIL. This will help the service technician determine that a fault has been fixed.
- Step-change Logic (SCL): The logic will detect an abrupt change from a no-fault condition to a fault condition. The SCL will be active after the 4th DCMS monitor cycle and will also use a 2-trip MIL. This will illuminate the MIL when a fault is instantaneously induced.
- Normal EWMA (NORM): This is the normal mode of operation and uses an Exponentially Weighted Moving Average (EWMA) to filter the EONV test data. It is employed after the 4th EONV test and will illuminate a MIL during the drive cycle where the EWMA value exceeds the fault threshold. (1 trip MIL).

Rear O2 DFSO Response Monitor Operation:	
DTCs	P013A - O2 Sensor Slow Response - Rich to Lean (Bank 1 Sensor 2) P013C - O2 Sensor Slow Response - Rich to Lean (Bank 2 Sensor 2) P013E - O2 Sensor Delayed Response - Rich to Lean (Bank 1 Sensor 2) (sensor stuck in range) P014A - O2 Sensor Delayed Response - Rich to Lean (Bank 2 Sensor 2) (sensor stuck in range)
Monitor execution	Once per driving cycle, after 3 DFSO events.
Monitor Sequence	> 30 seconds time in lack of movement test (UEGO only), > 30 seconds time in lack of switch test, front HO2S/UEGO response test complete, HO2S 2 and 3 functional tests complete, HO2S/UEGO heater voltage and current checks complete, FAOS monitor system bias maturity met (UEGO applications only)
Sensors OK	ECT, IAT, MAF, VSS, TP, ETC, FRP, EGR, VCT, VMV/EVMV, CVS, FTP, CKP, CMP, ignition coils, injectors, no misfire DTCs, no system failures affecting fuel, no EVAP gross leak failure, UEGO heaters OK, rear HO2S heaters OK, no "lack of switching" malfunction, no "lack of movement" malfunction, no UEGO circuit malfunction, no rear stream 2 HO2S circuit malfunction, no rear stream 2 HO2S functional DTCs, Not performing CSER spark retard. Flex fuel composition not changing. No intrusive EGO monitors running.
Monitoring Duration	3 DFSO events, 450 seconds on the FTP.

Typical DFSO Response Monitor entry conditions:		
Entry condition	Minimum	Maximum
Air Mass	0.5	6
Vehicle Speed		90
Inlet Air Temp		140
Engine Coolant Temp	155 °F	240 °F
Catalyst Temperature (Inferred)	800 °F	1600 °F
Rear Ego Tip Temperature (Inferred)	800 °F	
Fuel Level	15%	
Fuel In Control	-5%	5%
Adaptive Fuel Within Limits	-5%	5%
Battery Voltage	11.0 Volts	18.0 Volts
Rich Voltage on downstream CMS sensor(s)	0.6 Volts	
Rich Voltage on upstream HEGO / UEGO sensor(s)	0.45 Volts (HEGO)	1 (UEGO)

Typical DFSO response rate malfunction thresholds:

Rich to lean slew rate thresholds:

Normal Threshold	= > 0.0 mV/sec
Fast Initial Response Threshold	= > 0.0 mV/sec
Step Change Threshold	= > 0.3 mV/sec

Note that the thresholds use a normalized offset and the threshold is set at "zero".

Typical DFSO delayed response malfunction thresholds:

Successive failures are counted up (5 to 10 faults). Monitor will now intrusively force rich fuel to run the test.

Intrusive controls will time out based on drivability (1 to 2 sec).

Successive drivability failures are counted up (3 faults).

Intrusive controls will now time out at a slower time (5 to 10 sec) and count a fault. After 3 faults are counted, a DTC is set.

J1979 DFSO response rate Mode \$06 Data

Monitor ID	Test ID	Description for CAN	
\$02	\$85	HO2S12 Fuel Shut off Rich to Lean Response Rate	mV/sec
\$02	\$86	HO2S12 Fuel Shut off Rich to Lean Response Time	msec
\$06	\$85	HO2S22 Fuel Shut off Rich to Lean Response Rate	mV/sec
\$06	\$86	HO2S22 Fuel Shut off Rich to Lean Response Time	msec

Rear HO2S Heaters,

The HO2S heaters are monitored for proper voltage and current. A HO2S heater voltage fault is determined by turning the heater on and off and looking for corresponding voltage change in the heater output driver circuit in the PCM.

A separate current-monitoring circuit monitors heater current once per driving cycle. The heater current is actually sampled three times. If the current value for two of the three samples falls below a calibratable threshold, the heater is assumed to be degraded or malfunctioning. (Multiple samples are taken for protection against noise on the heater current circuit.)

HO2S Heater Monitor Operation:	
DTCs Sensor 2	P0141 O2 Heater Circuit, Bank 1 P0161 O2 Heater Circuit, Bank 2 P0054 O2 Heater Resistance, Bank 1 P0060 O2 Heater Resistance, Bank 2
DTCs Sensor 3	P0147 O2 Heater Circuit, Bank 1 P0167 O2 Heater Circuit, Bank 2 P0055 HO2s Heater Resistance, Bank 1 P0061 HO2s Heater Resistance, Bank 2
Monitor execution	once per driving cycle for heater current, continuous for voltage monitoring
Monitor Sequence	Heater current monitor: Stream 1 HO2S/UEGO response test complete, Stream 2 and 3 HO2S functional tests complete, HO2S/UEGO heater voltage check complete
Sensors OK	Heater current monitor: no HO2S/UEGO heater voltage DTCs
Monitoring Duration	< 10 seconds for heater voltage check, < 5 seconds for heater current check

Typical HO2S heater monitor entry conditions:		
Entry condition	Minimum	Maximum
Inferred HO2S 2/3 Temperature (heater voltage check only)	400 °F	1400 °F
Inferred HO2S 2 Temperature (heater current check only)	250 °F	1400 °F
Inferred HO2S 3 Temperature (heater current check only)	250 °F	1400 °F
HO2S 1/2/3 heater-on time (heater current check only)	30 seconds	
Engine RPM (heater current check only)		5000 rpm
Battery Voltage (heater voltage check only)	11.0	18.0 Volts

Typical HO2S heater check malfunction thresholds:

Smart driver status indicated malfunction

Number monitor retries allowed for malfunction ≥ 30

Heater current outside limits:

- < 0.220 amps or > 3 amps, (NTK)
- < 0.400 amps or > 3 amps, (Bosch)
- < 0.465 amps or > 3 amps, (NTK Fast Light Off)
- < 0.230 amps or > 3 amps, (Bosch Fast Light Off)

J1979 HO2S Heater Mode \$06 Data

Monitor ID	Test ID	Description for CAN	Units
\$02	\$81	HO2S12 Heater Current	Amps
\$06	\$81	HO2S22 Heater Current	Amps
\$03	\$81	HO2S13 Heater Current	Amps
\$07	\$81	HO2S23 Heater Current	Amps

DPFE EGR System Monitor

The Delta Pressure Feedback EGR system is a closed loop EGR control system that uses Delta Pressure Feedback EGR sensor (DPFE) to measure EGR flow across an orifice in the EGR tube. When the EGR valve is open, a pressure differential is created across the orifice and measured by the DPFE sensor. This DPFE measurement is used to control the EGR vacuum regulator (EVR), which provides vacuum to open and modulate the EGR valve itself.

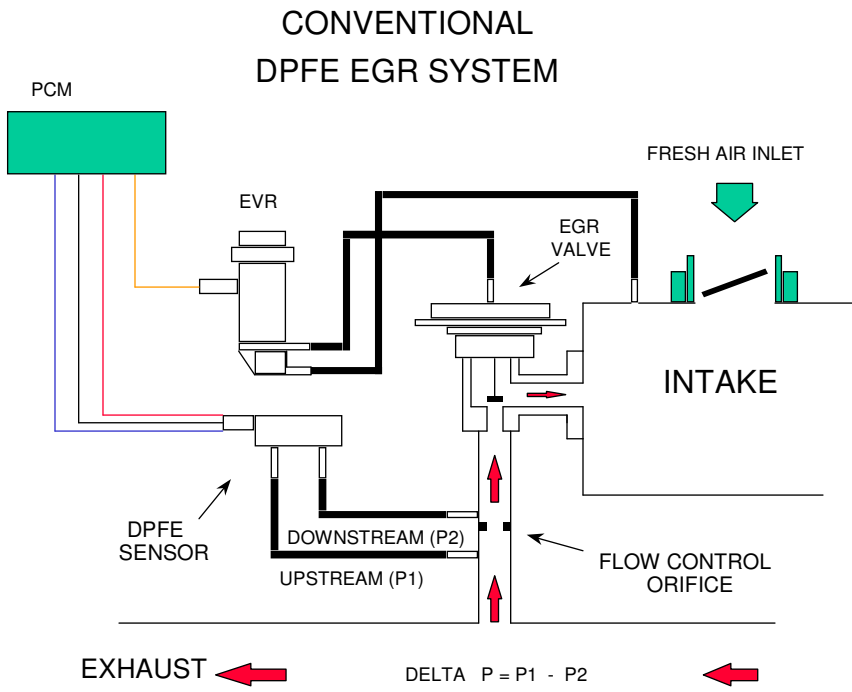

DPFE EGR Monitor

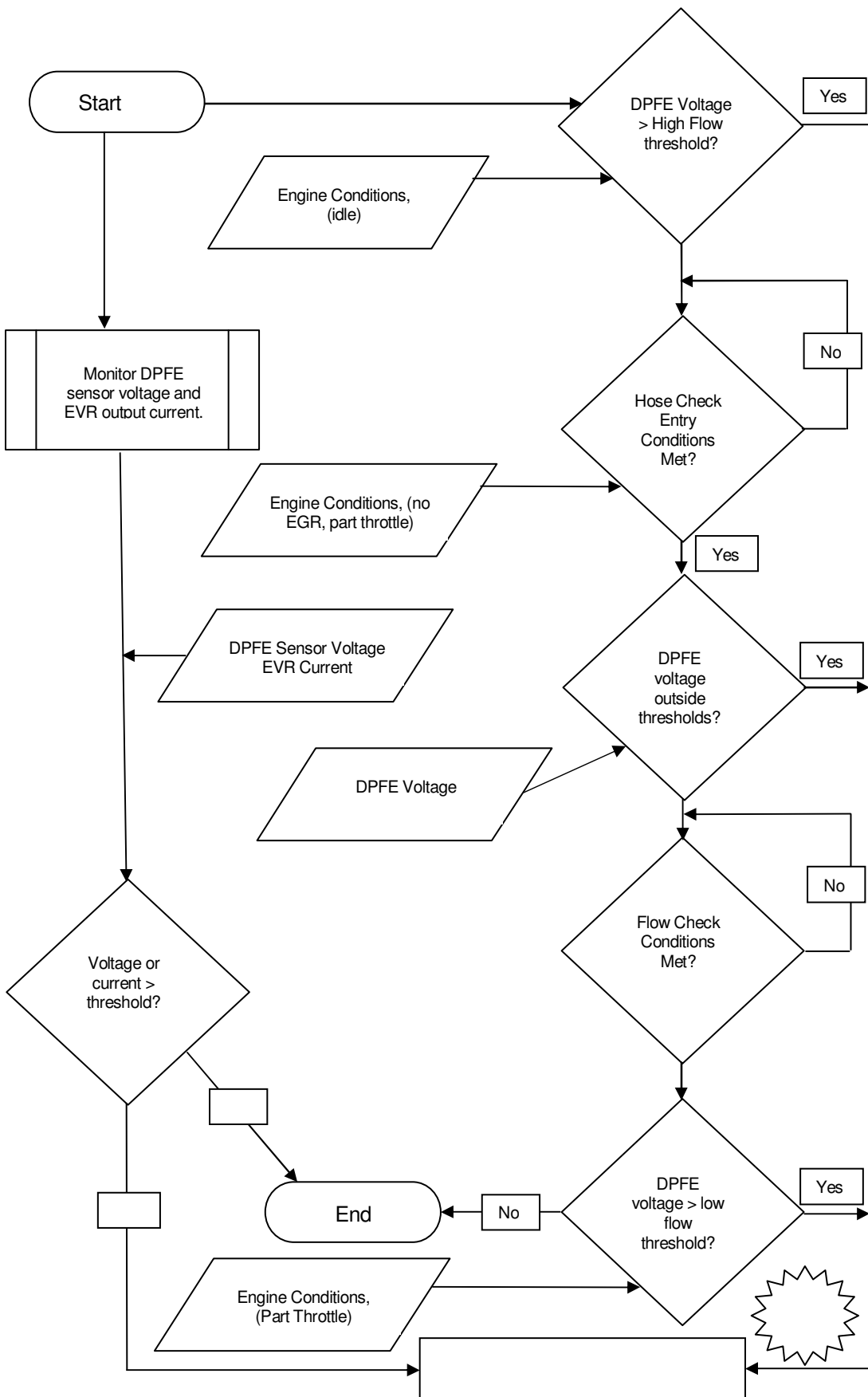

The Delta Pressure Feedback EGR Monitor is a series of electrical tests and functional tests that monitor various aspects of EGR system operation.

First, the Delta Pressure Feedback EGR (DPFE) sensor input circuit is checked for out of range values (P1400 or P0405, P1401 or P0406). The Electronic Vacuum Regulator (EVR) output circuit is checked for opens and shorts (P1409 or P0403).

DPFE EGR Electrical Check Operation:	
DTCs	P1400 or P0405 - DPFE Circuit Low P1401 or P0406 - DPFE Circuit High P1409 or P0403 - EVR circuit open or shorted
Monitor execution	Continuous, during EGR monitor
Monitor Sequence	None
Sensors OK	
Monitoring Duration	4 seconds to register a malfunction

Typical DPFE EGR electrical check entry conditions:
EGR system enabled

Typical DPFE EGR electrical check malfunction thresholds:
DPFE sensor outside voltage: > 4.96 volts, < 0.0489 volts
EVR solenoid smart driver status indicates open/short

The DPFE sensor is a ceramic, capacitive-type pressure transducer that monitors the differential pressure across a metering orifice located in the orifice tube assembly. The differential pressure feedback sensor receives this signal through two hoses referred to as the downstream pressure hose (REF SIGNAL) and upstream pressure hose (HI SIGNAL). The HI and REF hose connections are marked on the aluminum DPFE sensor housing for identification (note that the HI signal uses a larger diameter hose). There are two styles of DPFE sensors. The newer, plastic housing utilizes a 1.0-volt offset (zero reading) whereas the older, aluminum housing utilizes either a 0.5-volt or 1.0-volt offset. See the ESM EGR section for the 0.5-volt offset transfer function. The slopes for either offset are identical.

DPFE Sensor Transfer Function		
DPFE volts = $V_{ref} [(0.683 * \text{Delta Pressure}) + 20] / 100$		
Volts	A/D Counts in PCM	Delta Pressure, Inches H ₂ O
0.0489	10	-27.9
0.76	156	-7.0
1.0	204	0
1.24	254	7.0
2.02	415	30
3.05	624	60
4.07	834	90
4.96	1015	116

Note: EGR normally has large amounts of water vapor that are the result of the engine combustion process. During cold ambient temperatures, under some circumstances, water vapor can freeze in the DPFE sensor, hoses, as well as other components in the EGR system. In order to prevent MIL illumination for temporary freezing, the following logic is used:

If an EGR system malfunction is detected above 32 °F, the EGR system and the EGR monitor is disabled for the current driving cycle. A DTC is stored and the MIL is illuminated if the malfunction has been detected on two consecutive driving cycles.

If an EGR system malfunction is detected below 32 °F, only the EGR system is disabled for the current driving cycle. A DTC is not stored and the I/M readiness status for the EGR monitor will not change. The EGR monitor, however, will continue to operate. If the EGR monitor determined that the malfunction is no longer present (i.e., the ice melts), the EGR system will be enabled and normal system operation will be restored.

The differential pressure indicated by the DPFE sensor is also checked at idle with zero requested EGR flow to perform the high flow check. If the differential pressure exceeds a calibratable limit, it indicates a stuck open EGR valve or debris temporarily lodged under the EGR valve seat (P0402).

DPFE EGR Stuck open Check Operation:	
DTCs	P0402
Monitor execution	once per driving cycle
Monitor Sequence	Done after electrical tests
Sensors OK	CPS, ECT, IAT, MAF, TP
Monitoring Duration	10 seconds to register a malfunction

Typical DPFE EGR stuck open check entry conditions:		
Entry Condition	Minimum	Maximum
EVR Duty Cycle (EGR commanded off)	0%	0%
Engine RPM (after EGR enabled)	at idle	Idle

Typical DPFE EGR stuck open check malfunction thresholds:
DPFE sensor voltage at idle versus engine-off signal: > 0.6 volts

J1979 DPFE EGR Stuck Open Mode \$06 Data			
Monitor ID	Test ID	Description for CAN Conventional DPFE	Units
\$31	\$84	Delta pressure for stuck open test and threshold	kPa

On conventional Delta PFE systems, after the vehicle is started, during vehicle acceleration, the differential pressure indicated by the DPFE sensor at zero EGR flow is checked to ensure that both hoses to the DPFE sensor are connected. Under this condition, the differential pressure should be zero. If the differential pressure indicated by the DPFE sensor exceeds a maximum positive threshold, a downstream DPFE hose malfunction is indicated (P1406). If the differential pressure falls below a minimum negative threshold, an upstream DPFE hose malfunction is indicated (P1405).

DPFE EGR Hose Check Operation:	
DTCs	P1405 - Upstream Hose Off or Plugged P1406 – Downstream Hose Off or Plugged
Monitor execution	once per driving cycle
Monitor Sequence	After P0402 test completed
Sensors OK	MAF
Monitoring Duration	4 seconds to register a malfunction

Typical DPFE EGR hose check entry conditions:		
Entry Condition	Minimum	Maximum
EVR Duty Cycle (EGR commanded off)	0%	0%
Mass Air Flow		8 lb/min
Inferred exhaust backpressure	13 in H ₂ O	

Typical DPFE EGR hose check malfunction thresholds:
DPFE sensor voltage: < 7 in H ₂ O, > 7 in H ₂ O

J1979 DPFE EGR Hose Check Mode \$06 Data			
Monitor ID	Test ID	Description for CAN Conventional DPFE	
\$31	\$80	Delta pressure for upstream hose test and threshold	kPa
\$31	\$81	Delta pressure for downstream hose test and threshold	kPa

After the vehicle has warmed up and normal EGR rates are being commanded by the PCM, the low flow check is performed. Since the EGR system is a closed loop system, the EGR system will deliver the requested EGR flow as long as it has the capacity to do so. If the EVR duty cycle is very high (greater than 80% duty cycle), the differential pressure indicated by the DPFE sensor is evaluated to determine the amount of EGR system restriction. If the differential pressure is below a calibratable threshold, a low flow malfunction is indicated (P0401).

EGR Flow Check Operation:	
DTCs	P0401 – Insufficient Flow
Monitor execution	once per driving cycle
Monitor Sequence	Done after hose tests for conventional DPFE, after P0402 for ESM
Sensors OK	CPS, ECT, IAT, MAF, TP
Monitoring Duration	70 seconds to register a malfunction

Typical EGR flow check entry conditions:		
Entry Condition	Minimum	Maximum
EVR Duty Cycle	80%	100%
Engine RPM		2500 rpm
Mass Air Flow Rate of Change		6% program loop
Inferred manifold vacuum	6 in Hg	10 in Hg

Typical EGR flow check malfunction thresholds:
DPFE sensor voltage: < 6 in H ₂ O

J1979 EGR Flow Check Mode \$06 Data			
Monitor ID	Test ID	Description for CAN Conventional DPFE	Units
\$31	\$85	Delta pressure for flow test and threshold	kPa

I/M Readiness Indication

If the inferred ambient temperature is less than 32 °F, or greater than 140 °F, or the altitude is greater than 8,000 feet (BARO < 22.5 "Hg), the EGR monitor cannot be run reliably. In these conditions, a timer starts to accumulate the time in these conditions. If the vehicle leaves these extreme conditions, the timer starts decrementing, and, if conditions permit, will attempt to complete the EGR flow monitor. If the timer reaches 500 seconds, the EGR monitor is disabled for the remainder of the current driving cycle and the EGR Monitor I/M Readiness bit will be set to a "ready" condition after one such driving cycle. Starting in the 2002 MY, vehicles will require two such driving cycles for the EGR Monitor I/M Readiness bit to be set to a "ready" condition.

ESM DPFE EGR System Monitor

In the 2002.5 MY, Ford introduced a revised DPFE system. It functions in the same manner as the conventional DPFE system; however, the various system components have been combined into a single component called the EGR System Module (ESM). This arrangement increases system reliability while reducing cost. By relocating the EGR orifice from the exhaust to the intake, the downstream pressure signal measures Manifold Absolute Pressure (MAP). The ESM will provide the PCM with a differential DPFE signal, identical to the conventional DPFE system. The DPFE signal is obtained by electrically subtracting the MAP and P1 pressure signals and providing this signal to the DPFE input on the PCM. 2003 MY and later implementations of the ESM system has a separate input to the PCM for the MAP sensor signal.

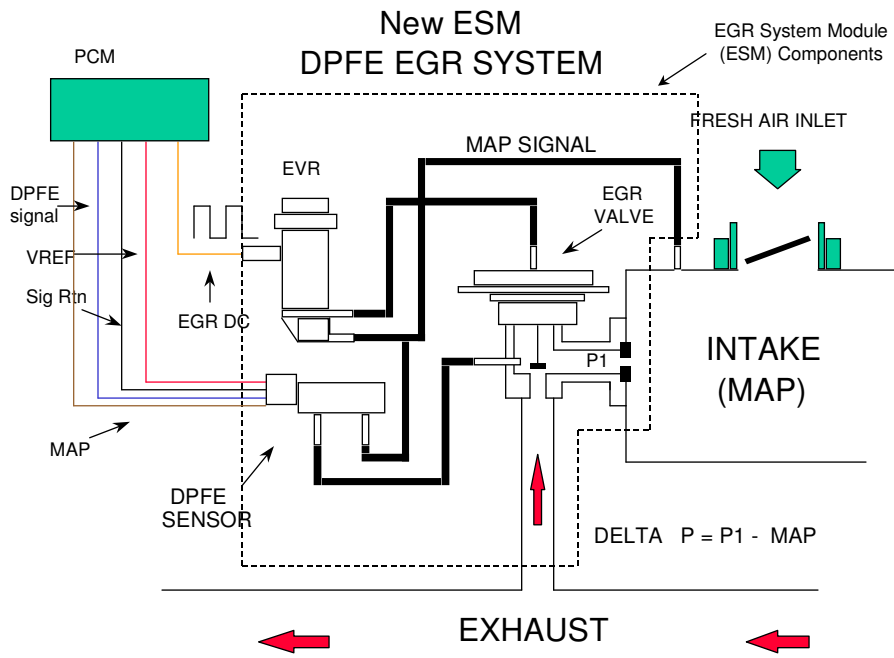

ESM DPFE EGR Monitor

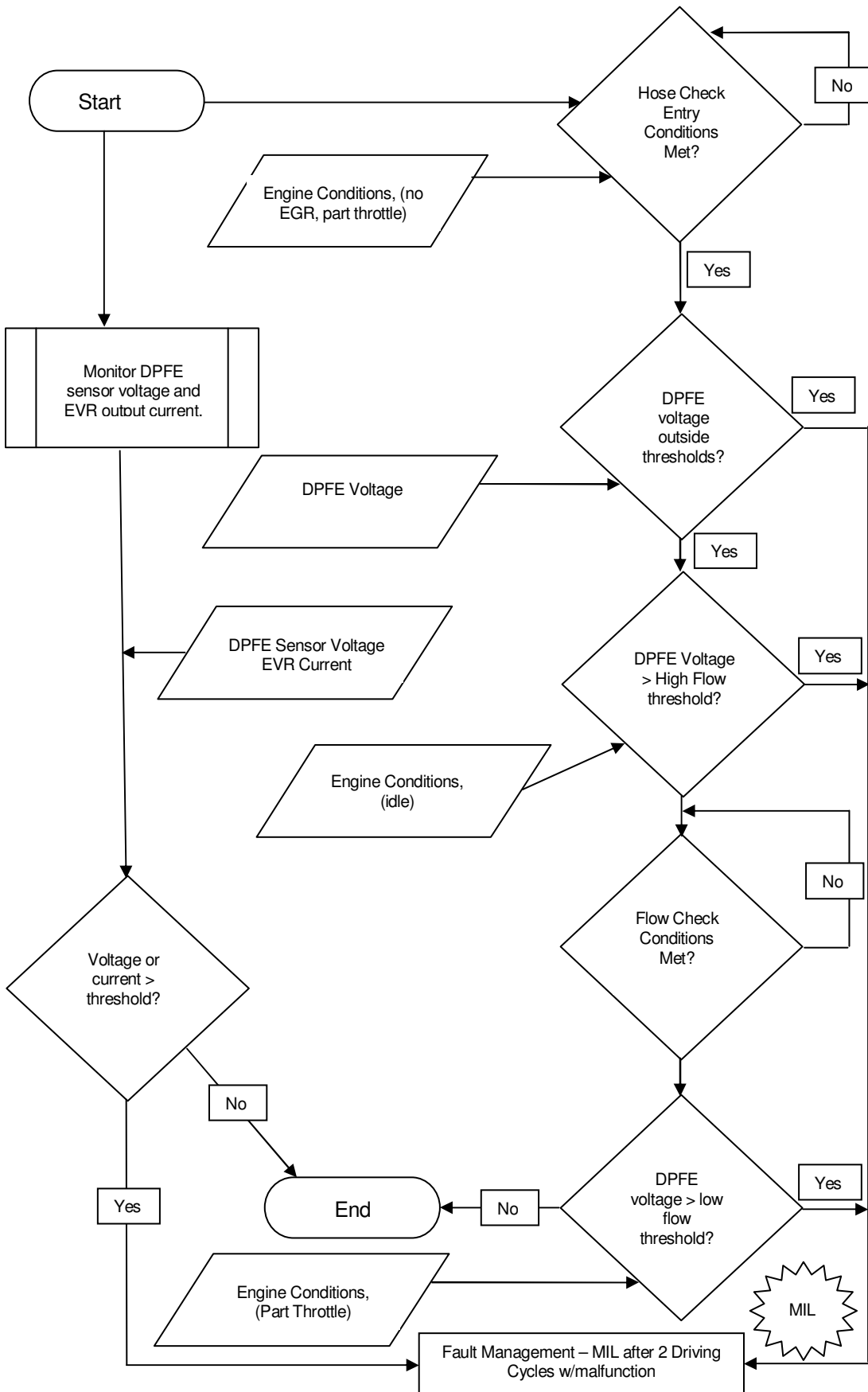

The ESM Delta Pressure Feedback EGR Monitor is a series of electrical tests and functional tests that monitor various aspects of EGR system operation.

First, the Delta Pressure Feedback EGR (DPFE) sensor input circuit is checked for out of range values (P1400 or P0405, P1401 or P0406). The Electronic Vacuum Regulator (EVR) output circuit is checked for opens and shorts (P1409 or P0403).

EGR Electrical Check Operation:	
DTCs	P1400 or P0405 - DPFE Circuit Low P1401 or P0406 - DPFE Circuit High P1409 or P0403 - EVR circuit open or shorted
Monitor execution	Continuous, during EGR monitor
Monitor Sequence	None
Sensors OK	
Monitoring Duration	4 seconds to register a malfunction

Typical EGR electrical check entry conditions:
EGR system enabled

Typical EGR electrical check malfunction thresholds:
DPFE sensor outside voltage: > 4.96 volts, < 0.0489 volts
EVR solenoid smart driver status indicates open/short

DPFE Sensor Transfer Function		
ESM DPFE volts = $V_{ref} [(0.683 * \text{Delta Pressure}) + 10] / 100$		
Volts	A/D Counts in PCM	Delta Pressure, Inches H ₂ O
0.0489	10	-13.2
0.26	53	-7.0
0.5	102	0
0.74	151	7.0
1.52	310	30
2.55	521	60
3.57	730	90
4.96	1015	130.7

Note: EGR normally has large amounts of water vapor that are the result of the engine combustion process. During cold ambient temperatures, under some circumstances, water vapor can freeze in the DPFE sensor, hoses, as well as other components in the EGR system. In order to prevent MIL illumination for temporary freezing, the following logic is used:

If an EGR system malfunction is detected above 32 °F, the EGR system and the EGR monitor is disabled for the current driving cycle. A DTC is stored and the MIL is illuminated if the malfunction has been detected on two consecutive driving cycles.

If an EGR system malfunction is detected below 32 °F, only the EGR system is disabled for the current driving cycle. A DTC is not stored and the I/M readiness status for the EGR monitor will not change. The EGR monitor, however, will continue to operate. If the EGR monitor determined that the malfunction is no longer present (i.e., the ice melts), the EGR system will be enabled and normal system operation will be restored.

The ESM may provide the PCM with a separate, analog Manifold Absolute Pressure Sensor (MAP) signal. For the 2006 MY, the MAP signal has limited use within the PCM. It may be used to read BARO (key on, then updated at high load conditions while driving) or to modify requested EGR rates. Note that if the MAP pressure-sensing element fails in the ESM fails, the DPFE signal is also affected. Therefore, this MAP test is only checking the circuit from the MAP sensing element to the PCM.

The MAP sensor is checked for opens, shorts, or out-of-range values by monitoring the analog-to-digital (A/D) input voltage.

MAP Sensor Check Operation	
DTCs	P0107 (low voltage), P0108 (high voltage)
Monitor execution	continuous
Monitor Sequence	None
Sensors OK	not applicable
Monitoring Duration	5 seconds to register a malfunction

MAP electrical check entry conditions:
Battery voltage > 11.0 volts

Typical MAP sensor check malfunction thresholds:
Voltage < 0.024 volts or voltage > 4.96 volts

On ESM DPFE systems, after the vehicle is started, the differential pressure indicated by the ESM DPFE sensor at idle, at zero EGR flow is checked to ensure that both hoses to the ESM DPFE sensor are connected. At idle, the differential pressure should be zero (both hoses see intake manifold pressure). If the differential pressure indicated by the ESM DPFE sensor exceeds a maximum threshold or falls below a minimum threshold, an upstream or downstream hose malfunction is indicated (P1405, P1406).

ESM DPFE EGR Hose Check Operation:	
DTCs	P1405 - Upstream Hose Off or Plugged P1406 – Downstream Hose Off or Plugged
Monitor execution	once per driving cycle
Monitor Sequence	after electrical checks completed
Sensors OK	MAF
Monitoring Duration	10 seconds to register a malfunction

Typical ESM DPFE EGR hose check entry conditions:		
Entry Conditions	Minimum	Maximum
EVR Duty Cycle (EGR commanded off)	0%	0%
Closed throttle (warm engine idle)		
Engine Coolant Temperature	150 °F	220 °F

Typical ESM EGR hose check malfunction thresholds:
DPFE sensor voltage: < -0.122 volts (-11.06 in H ₂ O), > 4.69 volts (122.82 in H ₂ O)

J1979 Mode \$06 Data			
Monitor ID	Test ID	Description for CAN ESM DPFE	
\$32	\$82	Delta pressure for upstream hose test and threshold	kPa
\$32	\$83	Delta pressure for downstream hose test and threshold	kPa

Note: OBD monitor ID \$32, Test ID \$82 (upstream hose test) may erroneously show a failing test result when no P1405 DTC is present. This is caused by an incorrect max limit in the software. The incorrect max limit will show a negative value (approx -32 kPa). The correct max limit will show a positive value (approx. +32 kPa). Early production vehicles may exhibit this issue until the software is corrected by a production running change or service fix.

Next, the differential pressure indicated by the DPFE sensor is also checked at idle with zero requested EGR flow to perform the high flow check. If the differential pressure exceeds a calibratable limit, it indicates a stuck open EGR valve or debris temporarily lodged under the EGR valve seat (P0402).

EGR Stuck open Check Operation:	
DTCs	P0402
Monitor execution	once per driving cycle
Monitor Sequence	done after hose tests completed
Sensors OK	CPS, ECT, IAT, MAF, TP, MAP (P0106/7/8)
Monitoring Duration	10 seconds to register a malfunction

Typical EGR stuck open check entry conditions:		
Entry Condition	Minimum	Maximum
EVR Duty Cycle (EGR commanded off)	0%	0%
Engine RPM (after EGR enabled)	at idle	Idle

Typical EGR stuck open check malfunction thresholds:
DPFE sensor voltage at idle versus engine-off signal: > 0.6 volts

J1979 Mode \$06 Data			
Monitor ID	Test ID	Description for CAN ESM DPFE	Units
\$32	\$84	Delta pressure for stuck open test and threshold	kPa

After the vehicle has warmed up and normal EGR rates are being commanded by the PCM, the low flow check is performed. Since the EGR system is a closed loop system, the EGR system will deliver the requested EGR flow as long as it has the capacity to do so. If the EVR duty cycle is very high (greater than 80% duty cycle), the differential pressure indicated by the DPFE sensor is evaluated to determine the amount of EGR system restriction. If the differential pressure is below a calibratable threshold, a low flow malfunction is indicated (P0401).

EGR Flow Check Operation:	
DTCs	P0401 – Insufficient Flow
Monitor execution	once per driving cycle
Monitor Sequence	done after P0402 completed
Sensors OK	CPS, ECT, IAT, MAF, TP, MAP (P0106/7/8)
Monitoring Duration	70 seconds to register a malfunction

Typical EGR flow check entry conditions:		
Entry Condition	Minimum	Maximum
EVR Duty Cycle	80%	100%
Engine RPM		2500 rpm
Mass Air Flow Rate of Change		6% program loop
Inferred manifold vacuum	6 in Hg	10 in Hg

Typical EGR flow check malfunction thresholds:
DPFE sensor voltage: < 6 in H ₂ O

J1979 Mode \$06 Data			
Monitor ID	Test ID	Description for CAN ESM DPFE	Units
\$32	\$85	Delta pressure for flow test and threshold	kPa

I/M Readiness Indication

If the inferred ambient temperature is less than 32 °F, or greater than 140 °F, or the altitude is greater than 8,000 feet (BARO < 22.5 "Hg), the EGR monitor cannot be run reliably. In these conditions, a timer starts to accumulate the time in these conditions. If the vehicle leaves these extreme conditions, the timer starts decrementing, and, if conditions permit, will attempt to complete the EGR flow monitor. If the timer reaches 500 seconds, the EGR monitor is disabled for the remainder of the current driving cycle and the EGR Monitor I/M Readiness bit will be set to a "ready" condition after one such driving cycle. Starting in the 2002 MY, vehicles will require two such driving cycles for the EGR Monitor I/M Readiness bit to be set to a "ready" condition.

Stepper Motor EGR System Monitor – Non-intrusive Monitor

The Electric Stepper Motor EGR System uses an electric stepper motor to directly actuate an EGR valve rather than using engine vacuum and a diaphragm on the EGR valve. The EGR valve is controlled by commanding from 0 to 52 discrete increments or “steps” to get the EGR valve from a fully closed to fully open position. The position of the EGR valve determines the EGR flow. Control of the EGR valve is achieved by a non-feedback, open loop control strategy. Because there is no EGR valve position feedback, monitoring for proper EGR flow requires the addition of a MAP sensor.

Stepper Motor EGR System

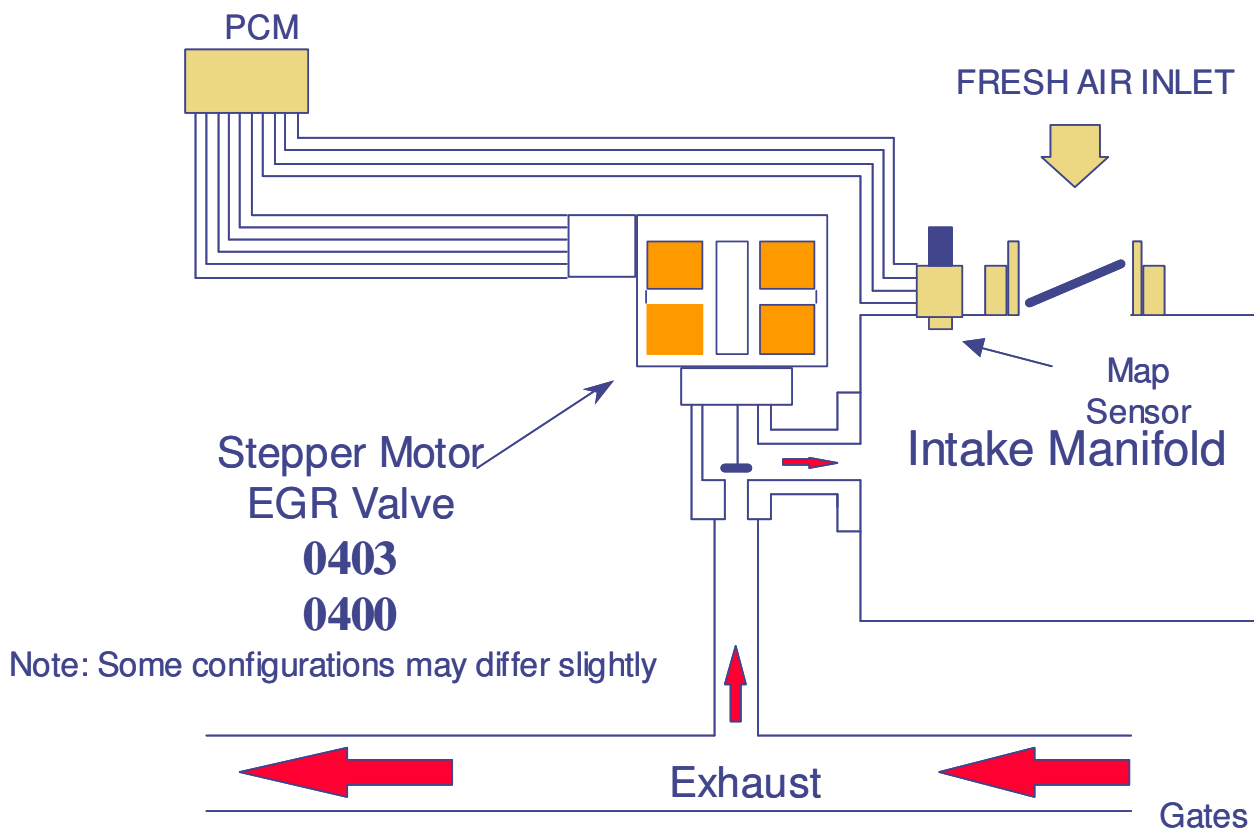

The Non-Intrusive Stepper Motor EGR Monitor consists of an electrical and functional test that checks the stepper motor and the EGR system for proper flow.

The stepper motor electrical test is a continuous check of the four electric stepper motor coils and circuits to the PCM. A malfunction is indicated if an open circuit, short to power, or short to ground has occurred in one or more of the stepper motor coils for a calibrated period of time. If a malfunction has been detected, the EGR system will be disabled, and additional monitoring will be suspended for the remainder of the driving cycle, until the next engine start-up.

EGR Stepper Monitor Electrical Check Operation:	
DTCs	P0403
Monitor execution	continuous
Monitor Sequence	none
Sensors OK	
Monitoring Duration	4 seconds to register a malfunction

Stepper motor electrical check entry conditions:
Battery voltage > 11.0 volts

Typical EGR electrical check malfunction thresholds:
"Smart" Coil Output Driver status indicates open or short to ground, or short to power

EGR flow is monitored using an analog Manifold Absolute Pressure Sensor (MAP). If a malfunction has been detected in the MAP sensor, the EGR monitor will not perform the EGR flow test.

The MAP sensor is checked for opens, shorts, or out-of-range values by monitoring the analog-to-digital (A/D) input voltage.

MAP Sensor Check Operation	
DTCs	P0107 (low voltage), P0108 (high voltage)
Monitor execution	continuous
Monitor Sequence	none
Sensors OK	not applicable
Monitoring Duration	5 seconds to register a malfunction

MAP electrical check entry conditions:
Battery voltage > 11.0 volts

Typical MAP sensor check malfunction thresholds:
Voltage < 0.024 volts or voltage > 4.96 volts

The MAP sensor is also checked for rational values. The value of inferred MAP is checked against the actual value of MAP at idle and non-idle engine operating conditions.

MAP Sensor Rationality Check Operation	
DTCs	P0106
Monitor execution	continuous
Monitor Sequence	None
Sensors OK	not applicable
Monitoring Duration	10 seconds to register a malfunction

Typical MAP Rationality check entry conditions:		
Entry Conditions	Minimum	Maximum
Change in load		5%
Engine rpm	500 rpm	1800 rpm

Typical MAP Rationality check malfunction thresholds:
Difference between inferred MAP and actual MAP > 10 in Hg

The MAP sensor is also checked for intermittent MAP faults.

MAP Sensor Intermittent Check Operation	
DTCs	P0109 (non-MIL)
Monitor execution	Continuous
Monitor Sequence	None
Sensors OK	not applicable
Monitoring Duration	2 seconds to register a malfunction

Typical MAP Intermittent check malfunction thresholds:
Voltage < 0.024 volts or voltage > 4.96 volts

After the vehicle has warmed up and normal EGR rates are being commanded by the PCM, the EGR flow test is performed. The flow test is performed once per drive-cycle after the remaining entry conditions required to initiate the test are satisfied.

The EGR flow test is done by observing the behavior of two different values of MAP - the analog MAP sensor reading, and inferred MAP, (MAP calculated from the Mass Air Flow Sensor, throttle position, rpm, BARO, etc.). The calculation of inferred MAP is not compensated for EGR flow and, therefore, does not account for the effects of EGR flow whereas measured MAP does respond to the effects of EGR flow. The amount of EGR flow can therefore be calculated by looking at the difference between measured MAP and inferred MAP.

Measured MAP can be thought of as consisting of three contributors: fresh air drawn into the intake manifold, EGR flow, and a noise/variability term. The following equation describes this:

$$P_{map} = P_{maf} + P_{egr} + P_{noise}$$

Where: P_{map} = pressure in manifold measured by the MAP sensor

P_{maf} = fresh air pressure without EGR flow, inferred from the MAF sensor, also known as inferred MAP

P_{egr} = EGR flow pressure due to EGR flow

P_{noise} = any discrepancy between measured MAP and inferred MAP, without EGR

P_{maf} (inferred MAP) is determined by the amount of fresh air drawn into manifold as measured by the Mass Air Flow (MAF) sensor. Inferred MAP is determined during the engine mapping process with no EGR, as a function of rpm and load

P_{egr} , the pressure due to EGR contribution can be modeled in the following equation:

$$P_{egr} = K * (\text{Actual EGR} / \text{Desired EGR}) * \text{Desired EGR}$$

Where: K = converts EGR pressure to a percent EGR flow rate

By rearranging the equation:

$$\text{Actual EGR} / \text{Desired EGR} = P_{egr} / (K * \text{Desired EGR})$$

The ratio of actual to desired EGR will eventually be calculated by the EGR monitor and will reflect how accurately EGR is being delivered to the engine.

Some differences will always exist between measured MAP and inferred MAP due to hardware variations. Within steady engine operating conditions without EGR, it is reasonable to model any differences between inferred and measured MAP as an offset and slope that is a function of load. The offset and slope are learned at various loads. This correction can be represented as:

$$\text{MAP correction} = P_{noise} = M * \text{LOAD} + B$$

Where: B = offset between measured MAP and inferred MAP

M = slope which accounts for the difference between measured MAP and inferred MAP as a function of load

The terms B and M are learned and compensate for differences between measured MAP and inferred MAP.

Rearranging and substituting in the equations above results in the following system model:

$$\text{Actual EGR} / \text{Desired EGR} = (\text{measured MAP} - \text{inferred MAP} - \text{MAP correction}) / (K * \text{Desired EGR})$$

The Actual EGR / Desired EGR is called the "degradation index". A value near one indicates the system is functioning properly whereas a value near zero reflects severe flow degradation.

When the entry conditions for the flow test have been satisfied, a calibrated number of samples of the difference between measured MAP and inferred MAP are taken at low, medium and high load regions, with and without EGR, to learn the MAP correction terms and then calculate the degradation index. When the number of samples in each load region is complete, a degradation index value from zero to one is computed. A value near one indicates the system is functioning properly whereas a value near zero reflects EGR severe flow degradation.

The degradation index is compared to a calibrated threshold to determine if a low flow malfunction has occurred.

Once the EGR monitor has been completed, the counter for the number of samples in each load region is reset to zero. If an EGR flow malfunction has occurred, the P0400 DTC flow malfunction is registered.

Note: BARO is inferred at engine startup using the KOEO MAP sensor reading. It is updated during high, part-throttle, engine operation.

This monitor employs an Exponentially Weighted Moving Average (EWMA) algorithm to improve the robustness threshold of the degradation index. During normal customer driving, a malfunction will illuminate the MIL, on average, in 3 to 6 driving cycles. If KAM is reset (battery disconnected), a malfunction will illuminate the MIL in 2 driving cycles. See the section on EWMA for additional information.

EGR Flow Check Operation:	
DTCs	P0400
Monitor execution	once per driving cycle
Monitor Sequence	None
Sensors OK	CPS, ECT, IAT, MAF, MAP (P0106/7/8), TP, BARO not available yet
Monitoring Duration	200 seconds (600 data samples)

Typical EGR flow check entry conditions:		
Entry Condition	Minimum	Maximum
Engine RPM	1400 rpm	2600 rpm
Inferred Ambient Air Temperature	32 °F	140 °F
Engine Coolant Temperature	80 °F	250 °F
Engine RPM Steady (change/0.050 sec)		100 rpm
MAP Steady (change/0.050 sec)		0.5 in Hg
Engine Load Steady (change/0.050 sec)		1.5 %
BARO	22.5 " Hg	

Typical EGR flow check malfunction thresholds:
< 0.50 degradation index

J1979 Mode \$06 Data			
Monitor ID	Test ID	Description for CAN	Units
\$33	\$82	EGR Degradation Index	unitless

I/M Readiness Indication

If the inferred ambient temperature is less than 20 °F, greater than 130 °F, or the altitude is greater than 8,000 feet (BARO < 22.5 "Hg), the EGR flow test cannot be reliably done. In these conditions, the EGR flow test is suspended and a timer starts to accumulate the time in these conditions. If the vehicle leaves these extreme conditions, the timer starts decrementing, and, if conditions permit, will attempt to complete the EGR flow monitor. If the timer reaches 800 seconds, the EGR flow test is disabled for the remainder of the current driving cycle and the EGR Monitor I/M Readiness bit will be set to a "ready" condition after one such driving cycle. Two such consecutive driving cycles are required for the EGR Monitor I/M Readiness bit to be set to a "ready" condition.

PCV System Monitor

The PCV valve is installed into the rocker cover using a quarter-turn cam-lock design to prevent accidental disconnection. The PVC valve is connected to the intake manifold hose using a quick connect. Because the PCV valve has locking tabs and cannot be removed from the rocker cover without the use of special removal tools, the quick connect will be disconnected first in the event vehicle service is required. Molded plastic lines are typically used from the PCV valve to the intake manifold. The diameter of the lines and the intake manifold have been increased to 0.625" so that inadvertent disconnection of the lines after a vehicle is serviced will cause either an immediate engine stall or will not allow the engine to be restarted. In the event that the vehicle does not stall if the line between the intake manifold and PCV valve is inadvertently disconnected, the vehicle will have a large vacuum leak that will cause a Mass Air Flow equipped vehicle to run lean at idle. This will illuminate the MIL after two consecutive driving cycles and will store one or more of the following codes: Lack of O2 sensor switches, Bank 1 (P2195), Lack of O2 sensor switches Bank 2 (P2197), Fuel System Lean, Bank 1 (P0171), Fuel System Lean, Bank 2 (P0174)

The PCV valve may incorporate a heater on some applications. A heated PCV valve is shown below. The PCV valve is designed to last for the life of the vehicle and should not require servicing or replacement.

Rocker cover with nub for quarter-turn valve



PCV hose with quick connect

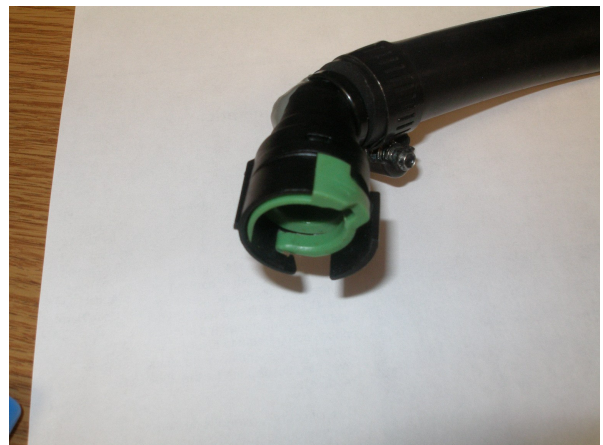

Heater quarter-turn PCV valve with heater



Assembled PCV system



Thermostat Monitor

Ford complies with the thermostat-monitoring requirement by using a slightly-modified version of the current “Insufficient temperature for closed-loop” test (P0125 or P0128). If the engine is being operated in a manner that is generating sufficient heat, the engine coolant temperature (ECT) or cylinder head temperature (CHT) should warm up in a predictable manner. A timer is incremented while the engine is at moderate load and vehicle speed is above a calibrated limit. The target/minimum timer value is based on ambient air temperature at start-up. If the timer exceeds the target time and ECT/CHT has not warmed up to the target temperature, a malfunction is indicated. The test runs if the start-up IAT temperature is below the target temperature. A 2-hour engine-off soak time is required to erase a pending or confirmed DTC. This feature prevents false-passes where engine coolant temperature rises after the engine is turned off during a short engine-off soak. The target temperature is calibrated to the thermostat regulating temperature minus 20 °F. For a typical 195 °F thermostat, the warm-up temperature would be calibrated to 175 °F.

Insufficient Temperature for Closed Loop Check Operation:

DTCs	P0125 or P0128
Monitor execution	Once per driving cycle
Monitor Sequence	None
Monitoring Duration	300 to 800 seconds within test entry conditions, based on ambient temperature

Typical P0125/P0128 check entry conditions:

Entry Condition	Minimum	Maximum
Vehicle speed	15 mph	
Intake Air Temp at Start-up	20 °F	Target ECT temp.
Engine Load	30%	
Engine off (soak) time to clear pending/confirmed DTC	2 hours	

Typical P0125/P0128 check malfunction thresholds:

Time period expired without reaching 175 °F target ECT temperature.

Time period is 300 to 800 seconds based on ambient temperature at start-up.

Enhanced Thermostat Monitor

For the 2009 MY, the thermostat test has been enhanced to reduce the time it takes to identify a malfunctioning thermostat. The enhanced monitor includes a model which infers engine coolant temperature.

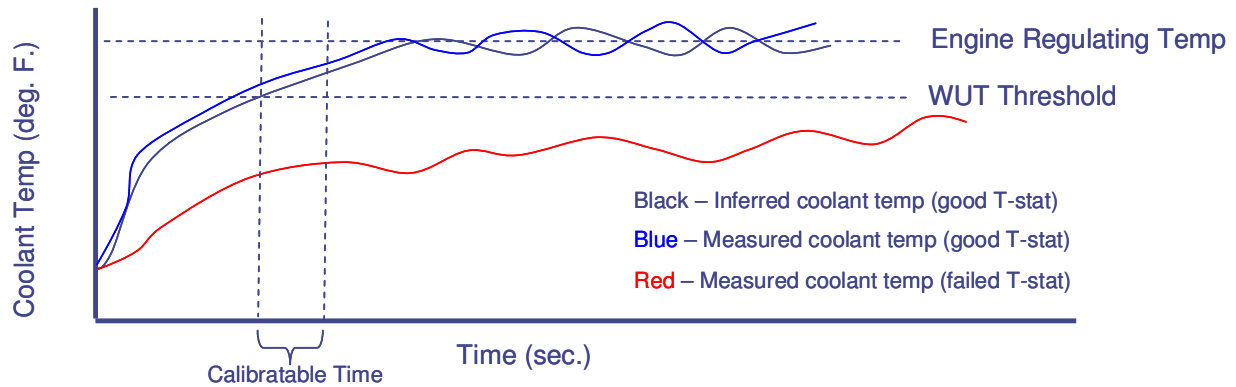

During a cold start, when the thermostat should be closed, the monitor uses a model of ECT to determine whether actual ECT should have crossed the Warm Up Temperature (WUT) threshold. Once the ECT model exceeds the WUT threshold, after a calibratable time delay, measured ECT is compared to the same WUT threshold to determine if ECT has warmed up enough. If ECT has warmed up to at least the WUT threshold, the thermostat is functioning properly. If ECT is too low, the thermostat is most likely stuck open and a P0128 is set.

The WUT threshold is normally set to 20 degrees F below the thermostat regulating temperature.

There are some circumstances that could lead to a false diagnosis of the thermostat. These are conditions where the vehicle cabin heater is extracting more heat than the engine is making. One example where this can occur is on large passenger vans which have "dual" heaters, one heater core for the driver and front passengers and another heater core for the passengers in the rear of the vehicle. At very cold ambient temperatures, even a properly functioning thermostat may never warm up to regulating temperature. Another example is a vehicle that is started and simply sits at idle with the heater on high and the defroster fan on high.

There are two features that are used to prevent a false thermostat diagnosis. For vehicles with dual heaters, the WUT threshold is reduced at cold ambient temperatures below 50 deg F. For cases where the engine is not producing sufficient heat, a timer is used to track time at idle or low load conditions (e.g. decels). If the ratio of time at idle/low load versus total engine run time exceeds 50% at the time the fault determination is made, the thermostat diagnostic does not make a fault determination for that driving cycle, i.e. "no-call".

THERMOSTAT MONITOR OPERATION

DTC	P0128 - Coolant Thermostat (Coolant temperature below thermostat regulating temperature)
Monitor Execution	Once per driving cycle, during a cold start
Monitoring Duration	Drive cycle dependent. Monitor completes in less than 300 seconds, when inferred ECT exceeds threshold (at 70 deg F)

TYPICAL THERMOSTAT MONITOR ENTRY AND COMPLETION CONDITIONS

Entry conditions	Minimum	Maximum
Engine Coolant Temperature at start	None	125 °F
Intake Air Temperature at start (ambient temp)	20 °F	None
Inferred Percent Ethanol (flex fuel vehicles only)	Learned	N/A
Completion condition	Minimum	Maximum
Modeled ECT	172 °F	None
Time Since Modeled ECT Exceeded WUT Threshold	300 sec.	None
Time at Idle/Low Load Compared with Total Engine Run Time	None	50%

TYPICAL MALFUNCTION THRESHOLD

Engine Coolant Temperature < 172 °F (for a typical 192 °F thermostat)

Cold Start Emission Reduction Component Monitor

The Cold Start Emission Reduction Component Monitor was introduced for the 2006 MY on vehicles that meet the LEV-II emission standards. The monitor works by validating the operation of the components of the system required to achieve the cold start emission reduction strategy, namely retarded spark timing, elevated idle airflow or VCT cam phasing.

Low Idle Airflow Test – Systems with Electronic Throttle Control

When the CSER strategy is enabled, the Electronic Throttle Control system will request a higher idle rpm, elevating engine airflow. Vehicles that have ETC and do not have a separate airflow test (P050A). Any fault that would not allow the engine to operate at the desired idle rpm during a cold start would be flagged by one of three ETC DTCs:

P2111 (throttle actuator control system stuck open),
P2112 throttle actuator control system stuck closed)
P2107 (throttle actuator control module processor/circuit test).

All three DTCs will illuminate the MIL in 2 driving cycles, and immediately illuminate the "ETC" light. These DTCS are also documented in the ETC section of this document.

For the 2009 MY, only the Fusion/Milan utilizes the CSER Component monitor with ETC.

Throttle Plate Controller and Actuator Operation:	
DTCs	P2107 – processor test (MIL) P2111 – throttle actuator system stuck open (MIL) P2112 – throttle actuator system stuck closed (MIL) Note: For all the above DTCs, in addition to the MIL, the ETC light will be on for the fault that caused the FMEM action.
Monitor execution	Continuous
Monitor Sequence	None
Monitoring Duration	60 msec for processor fault, 500 msec for stuck open/closed fault

Throttle Plate Controller and Actuator malfunction thresholds:	
P2111 - Desired throttle angle vs. actual throttle angle > 6 degrees	
P2112 - Desired throttle angle vs. actual throttle angle < 6 degrees	
P2107 - Internal processor fault, lost communication with main CPU	

Spark Timing Monitor

The powertrain control module is equipped with a "spark conduction capture" circuit which measures the timing and duration of the spark delivered by processing the flyback voltage signal from the primary side of the ignition coil. With CSER enabled, the spark control strategy will request retarded spark timing. While retarded spark timing is requested, the spark timing monitor compares the measured spark timing from the spark conduction capture circuit to the commanded spark timing from the spark control strategy. For the purpose of detecting spark timing failures, the spark timing monitor increments a fault filter if the measured spark timing is advanced by more than 5 degrees from the commanded spark timing. A failure is indicated if the fault filter exceeds a value of 200 (equivalent to a failure duration of approximately 4 seconds).

CSER spark timing test Operation:	
DTCs	P050B – Cold Start Ignition timing Performance
Monitor execution	Once per driving cycle, from startup with CSSRE active
Monitor Sequence	None
Sensors OK	
Monitoring Duration	~ 7 seconds

CSER typical spark timing test entry conditions:		
Entry Condition	Minimum	Maximum
Engine RPM	400 RPM	2000 RPM
No coil primary faults		
Engine position synchronized		
Cylinder identification synchronized		

CSRE typical spark timing test malfunction thresholds:
Spark advanced from desired > 5 deg.
Fault present for 4 seconds

Cold Start VCT Monitor

If the VCT cam phasing is used during a cold start to improved catalyst heating, the VCT system is checked functionally by monitoring the closed loop cam position error correction. If the proper cam position cannot be maintained and the system has an advance or retard error greater than the malfunction threshold, a cold start emission reduction (CSER) VCT control malfunction is indicated (P052A/P052B (Bank 1), P052C/P052D (Bank2)). This test is the same test that was used previously for monitoring the VCT system under Comprehensive Component Monitoring requirements.

CSER VCT Target Error Check Operation:]	
DTCs	P052A – Cold start camshaft position timing over-advanced (Bank 1) P052B – Cold start camshaft timing over-retarded (Bank 1) P052C – Cold start camshaft timing over-advanced (Bank 2) P052D – Cold start camshaft timing over-retarded (Bank 2)
Monitor execution	Continuous
Monitor Sequence	None
Sensors OK	
Monitoring Duration	5 seconds

Typical CSER VCT target error entry conditions:		
Entry condition	Minimum	Maximum
VCT control enabled and commanded to advance or retard cam during CSER	n/a	n/a
Time since start of CSER cam phase monitoring		60 seconds

Typical CSER VCT target error malfunction thresholds:
CSER Response/target error - VCT over-advance: 11 degrees
CSER Response/target error - VCT over-retard: 11 degrees
CSER Response/Stuck Pin – 10 degrees phasing commanded, and not seeing at least 2 degrees of movement.

Cold Start Emission Reduction System Monitor

The Cold Start Emission Reduction System Monitor is being introduced for the 2007 MY on vehicles that meet the LEV-II emission standards. It will eventually replace the Cold Start Emission Reduction Component Monitor. The Cold Start Emission Reduction (CSER) Monitor detects the lack of catalyst warm up resulting from a failure to apply sufficient CSER during a cold start. It does this by using the inferred catalyst temperature model to determine how closely the actual catalyst temperature follows the expected catalyst temperature during a cold start. How closely the actual temperature follows the expected temperature is reflected in a ratio which is compared with a calibratable threshold.

Temperatures Used

The actual catalyst temperature is the same inferred catalyst temperature that is used by other portions of the engine control system, including the CSER control system. The inputs to this actual temperature are measured engine speed, measured air mass, and commanded spark.

The expected catalyst temperature is calculated using the same algorithm as the actual catalyst temperature, but the inputs are different. Desired engine speed replaces measured engine speed, desired air mass replaces measured air mass, and desired cold start spark replaces commanded spark. The resulting temperature represents the catalyst temperature that is expected if CSER is functioning properly.

Ratio Calculation

A ratio is calculated to reflect how closely the actual temperature has followed the expected temperature. This ratio is the difference between the two temperatures at a certain time-since-start divided by the increase in expected temperature over the same time period. The ratio, then, provides a measure of how much loss of catalyst heating occurred over that time period.

This ratio correlates to tailpipe emissions. Therefore applying a threshold to it allows illumination of the MIL at the appropriate emissions level. The threshold is a function of ECT at engine start.

General CSER Monitor Operation

During the first 15 seconds of a cold start, the monitor checks the entry conditions, counts time in idle, and observes catalyst temperature.

If the expected change in catalyst temperature is large enough, the monitor calculates the ratio as described above. Otherwise the monitor does not make a call.

The monitor then begins the waiting period, which lasts from the time the ratio is calculated (15 seconds after engine start) until 300 seconds after engine start. This 5-minute wait allows time to diagnose other components and systems that affect the validity of the catalyst temperature model. During this waiting period, there are no constraints on drive cycle and the monitor cannot be disabled without turning off the key.

At the end of the waiting period, if no other faults that could compromise the validity of the catalyst temperature model are found, the monitor compares the ratio to the threshold.

If the ratio exceeds the threshold, the monitor considers the test a fail, and the monitor is complete.

If the ratio falls below the threshold, the monitor determines whether the idle time was sufficient. If so, it considers the test a pass and the monitor is complete. If idle time was not sufficient, the monitor does not make a pass call and does not complete. This prevents tip-ins from resulting in false passes.

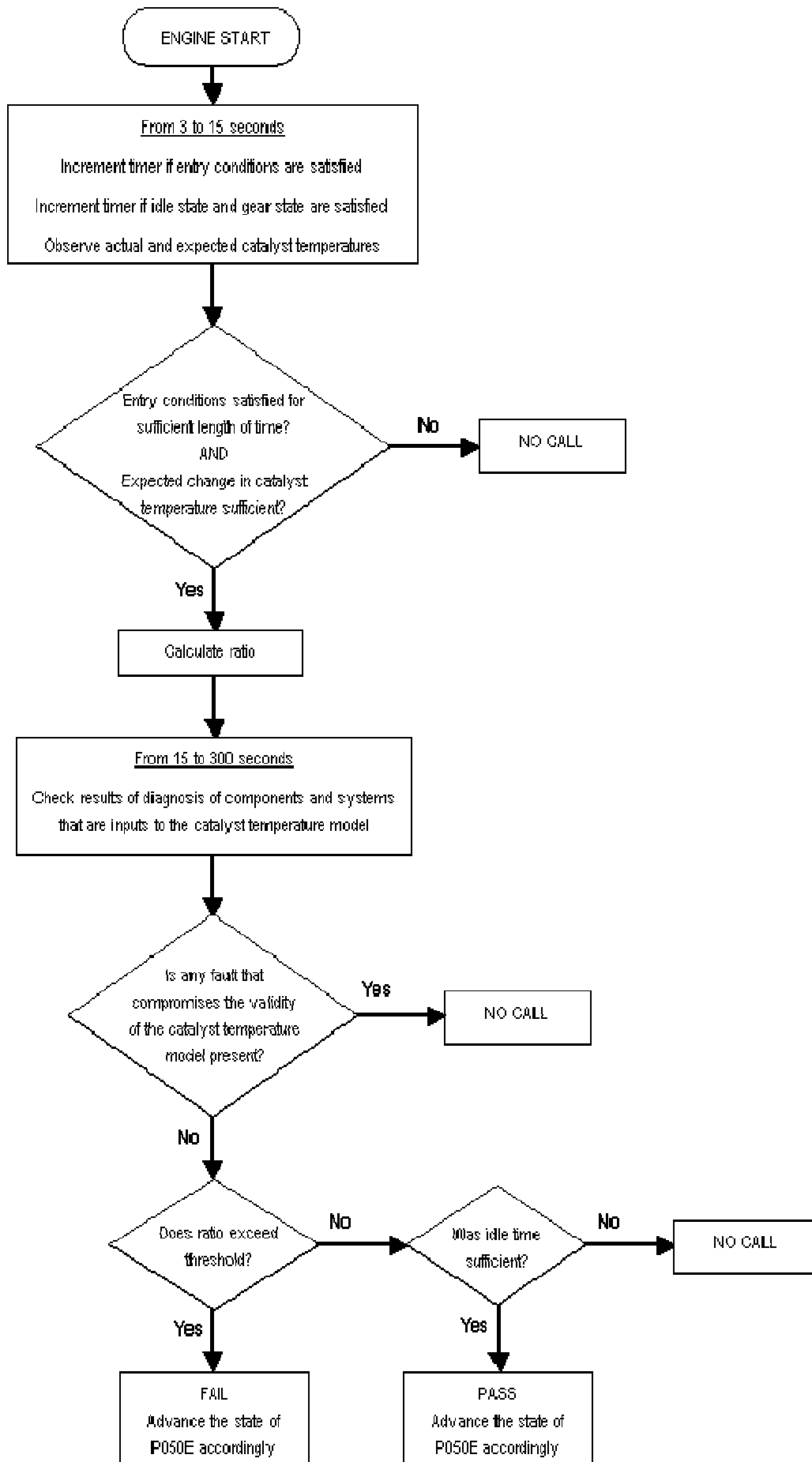

CSER MONITOR OPERATION	
DTC	P050E: Cold Start Engine Exhaust Temperature Out Of Range
Monitor Execution	Once per driving cycle, during a cold start
Monitor Sequence	Monitor data collection takes place during first 15 seconds of cold start
Sensors OK	No fault is present in any of the sensors or systems affecting the catalyst temperature model: Mass Air Flow (P0102, P0103), Throttle Position (P0122, P0123, P0222, P0223), Misfire (P0316, P0300-P0312), Injectors (P0201-P0212), Fuel System (P0171, P0172, P0174, P0175), Secondary Air (P0412, P2258), Crank Position Sensor (P0320), Ignition Coil (P0351-P0360), Intake Air Temp (P0112, P0113), Engine Coolant Temp/Cylinder Head Temp (P0117, P0118, P1289, P1290), Variable Cam Timing (P0010, P0020, P0011, P0012, P0021, P0022), Intake Manifold Runner Control (P2008).
Monitoring Duration	Monitor completes 300 seconds after initial engine start

TYPICAL CSER MONITOR ENTRY AND COMPLETION CONDITIONS		
Entry condition	Minimum	Maximum
Barometric Pressure	22 in. Hg	
Engine Coolant Temperature at Start	35 °F	100 °F
Catalyst Temperature at Start	35 °F	125 °F
Fuel Level	15%	
No Torque Reduction by Injector Cutout		
Power Takeout Not Active		
Completion condition	Minimum	Maximum
Length of Time Entry Conditions are Satisfied	11 sec.	
Expected Change in Catalyst Temperature	50 °F	
Time in Idle	10 sec.	
Selected Gear	Neutral	Drive

TYPICAL MALFUNCTION THRESHOLD
Cold start warm-up temperature ratio > 0.4

Variable Cam Timing System Monitor

Variable Cam Timing (VCT) enables rotation of the camshaft(s) relative to the crankshaft (phase-shifting) as a function of engine operating conditions. There are four possible types of VCT with DOHC engines:

- Intake Only (phase-shifting only the intake cam);
- Exhaust Only (phase-shifting only the exhaust cam);
- Dual Equal (phase-shifting the intake and exhaust cams equally);
- Dual Independent (phase-shifting the intake and exhaust cams independently).

All four types of VCT are used primarily to increase internal residual dilution at part throttle to reduce NO_x, and to improve fuel economy. This allows for elimination the external EGR system.

With Exhaust Only VCT, the exhaust camshaft is retarded at part throttle to delay exhaust valve closing for increased residual dilution and to delay exhaust valve opening for increased expansion work.

With Intake Only VCT, the intake camshaft is advanced at part throttle and WOT (at low to mid-range engine speeds) to open the intake valve earlier for increased residual dilution and close the intake valve earlier in the compression stroke for increased power. When the engine is cold, opening the intake valve earlier warms the charge which improves fuel vaporization for less HC emissions; when the engine is warm, the residual burned gasses limit peak combustion temperature to reduce NO_x formation.

With Dual Equal VCT, both intake and exhaust camshafts are retarded from the default, fully advanced position to increase EGR residual and improve fuel economy by reducing intake vacuum pumping losses. The residual charge for NO_x control is obtained by backflow through the late-closing exhaust valve as the piston begins its intake stroke.

The VCT system hardware consists of a control solenoid and a pulse ring on the camshaft. The PCM calculates relative cam position using the CMP input to process variable reluctance sensor pulses coming from the pulse ring mounted on the camshaft. Each pulse wheel has $N + 1$ teeth where N = the number of cylinders per bank. The N equally spaced teeth are used for cam phasing; the remaining tooth is used to determine cylinder # 1 position. Relative cam position is calculated by measuring the time between the rising edge of profile ignition pickup (PIP) and the falling edges of the VCT pulses.

The PCM continually calculates a cam position error value based on the difference between the desired and actual position and uses this information to calculate a commanded duty cycle for the VCT solenoid valve. When energized, engine oil is allowed to flow to the VCT unit thereby advancing and retarding cam timing. The variable cam timing unit assembly is coupled to the camshaft through a helical spline in the VCT unit chamber. When the flow of oil is shifted from one side of the chamber to the other, the differential change in oil pressure forces the piston to move linearly along the axis of the camshaft. This linear motion is translated into rotational camshaft motion through the helical spline coupling. A spring installed in the chamber is designed to hold the camshaft in the low-overlap position when oil pressure is too low (~15 psi) to maintain adequate position control. The camshaft is allowed to rotate up to 30 degrees.

Although the VCT system has been monitored under Comprehensive Component Monitoring requirements for many years, a new, emission-based VCT monitor is being introduced for the 2006 MY on vehicles that meet LEV-II emission standards. The intent of the new VCT monitoring requirements is to detect slow VCT system response that could cause emissions to increase greater than $1.5 * \text{std.}$ in addition to detecting functional problems (target errors).

The new logic calculates the instantaneous variance in actual cam position (the squared difference between actual cam position and commanded cam position), then calculates the long term variance using a rolling average filter (Exponentially Weighted Moving Average). Continued, slow response from the VCT system will eventually accumulate large variances.

This same logic will also detect target errors that were detected by the previous CCM monitor. If the VCT system is stuck in one place, the monitor will detect a variance which will quickly accumulate.

There are three variance indices that monitor cam variance in the retard direction, the advance direction, and for V-engines, the difference between banks. If any variance index is greater than the malfunction threshold, a VCT slow response/target error malfunction will be indicated (P0011, P0012 Bank 1, 0021, P0022 Bank 2). Target errors will tend to generate only a single over-advanced or over-retarded code while slow response will tend to generate both codes.

In addition, logic has been added to determine whether the camshaft and crankshaft are misaligned by one or more teeth. This test calculates the absolute offset between one of the camshaft teeth and the crankshaft missing tooth at idle when that can is at its stop. If the error is greater than the malfunction threshold, a cam/crank misalignment error will be indicated (P0016 Bank 1, P0018 Bank 2).

For systems that phase the cams immediately off of a cold start for reducing emissions or CSER (Cold Start Emissions Reduction) the cam position is monitored for functionality during this period of time. There are two ways to set failures.

- Error between the actual position and the expected position is calculated. If the error is greater than a specified amount, and the Error persists for a period of time, a P052x code is set designating over advanced or retarded and the bank number. The diagnostic is only executed during CSER phasing.
- The diagnostic also checks for a cam position request above a threshold for a period of time, and determines that the VCT actuator pin is stuck if the cam does not move from the locked position by a certain amount. This is also only done during CSER operation. If the locking pin is determined to be stuck then the Oil Control Solenoid (OCS) is cycled on and off for a calibratable amount to allow pressure to build in the system to unseat the locking pin. If attempts to unstick the locking pin fail, then a P052x code is set.

The in-use performance ratio numerator for the VCT monitor can be incremented only if the VCT system has been monitored for both functional and response faults. If the vehicle is operated in a manner that does not ask the VCT actuators to change position, it may not be possible to evaluate whether they are working properly. As a result, the in-use ratio numerator checks to see if the commanded VCT position changes sufficiently to detect possible target errors and with a sufficiently high rate to detect possible slow response. For each drive cycle in which both criteria are met, the VCT in-use performance numerator will be incremented.

Similar to the previous CCM monitor, the VCT solenoid output driver in the PCM is checked electrically for opens and shorts (P0010 Bank 1, P0020 Bank 2).

VCT Monitor Operation:	
DTCs	P0010 - Camshaft Position Actuator Circuit (Bank 1) P0011 - Cam Position Actuator Over Advanced (Bank 1) P0012 - Cam Position Actuator Over Retarded (Bank 1) P0016 - Crank/Cam Position Correlation (Bank 1) P0020 - Camshaft Position Actuator Circuit (Bank 2) P0021 - Cam Position Actuator Over Advanced (Bank 2) P0022 - Cam Position Actuator Over Retarded (Bank 2) P0018 – Crank/Cam Position Correlation (Bank 2)
Monitor execution	Continuous
Monitor Sequence	None
Sensors OK	IAT, ECT, EOT, IMRC, TP, MAF, CKP, and CMP
Monitoring Duration	5 - 10 seconds for circuit faults and functional checks, 300 seconds for target error

Typical VCT response/functional monitor entry conditions:		
Entry condition	Minimum	Maximum
Engine RPM (for P0016/P0018 only)	500	4500
Engine Coolant Temperature	32 °F	
Engine Oil Temperature		280 °F
VCT control enabled and commanded to advance or retard cam **	n/a	n/a
** VCT control of advance and retard by the engine is disabled in crank mode, when engine oil is cold (< 150 °F), while learning the cam/crank offset, while the control system is "cleaning" the solenoid oil passages, throttle actuator control in failure mode, and if one of the following sensor failures occur: IAT, ECT, EOT, MAF, TP, CKP, CMP, or IMRC.		

Typical VCT monitor malfunction thresholds:

VCT solenoid circuit: Open/short fault set by the PCM driver

Cam/crank misalignment: > or = one tooth difference, or 17 crank degrees

Response/target error - VCT over-advance variance too high: 40 to 700 degrees squared

Response/target error - VCT over-retard variance too high: 40 to 700 degrees squared

Response/target error - Cam bank-to-bank variance too high: 40 to 700; degrees squared

Typical In-Use Performance monitoring thresholds:

Monitoring thresholds to increment the numerator:

Amount of cam change required for target error fault: > 160 degrees squared

Amount of rate of change required for slow response fault: > 5 degrees squared

J1979 VCT Monitor Mode \$06 Data

Monitor ID	Test ID	Description for CAN	Units
\$35	\$80	Camshaft Advanced Position Error Bank 1	Unsigned, Angular degrees
\$35	\$81	Camshaft Retarded Position Error Bank 1	Unsigned, Angular degrees
\$36	\$80	Camshaft Advanced Position Error Bank 2	Unsigned, Angular degrees
\$36	\$81	Camshaft Retarded Position Error Bank 2	Unsigned, Angular degrees

Electronic Throttle Control

The Electronic Throttle Control (ETC) system uses a strategy that delivers engine or output shaft torque, based on driver demand, utilizing an electronically controlled throttle body. ETC strategy was developed mainly to improve fuel economy. This is possible by decoupling throttle angle (produces engine torque) from pedal position (driver demand). This allows the powertrain control strategy to optimize fuel control and transmission shift schedules while delivering the requested engine or wheel torque.

The Gen2 ETC system was first introduced in 2003MY Ford products. This system evolved into the Gen3 ETC system in 2008MY and the Gen4 ETC system in 2009MY. The Gen3 and Gen4 ETC systems made improvements over the Gen2 system by reducing complexity, improving reliability, and optimizing cost. The primary changes made for the Gen3 / Gen4 ETC systems were the following:

- Replace 3-track sensor Accelerator Pedal with 2-track sensor Accelerator Pedal.
- Introduce single plunger dual output brake switch.
- Integrate the Throttle Plate Position Controller (eTPPC) into the main processor within PCM.
- Reduce Quizzer complexity and integrate with the EONV function.

The Gen3 / Gen4 ETC systems have equivalent hardware systems with only software differences.

Gen 2 ETC System

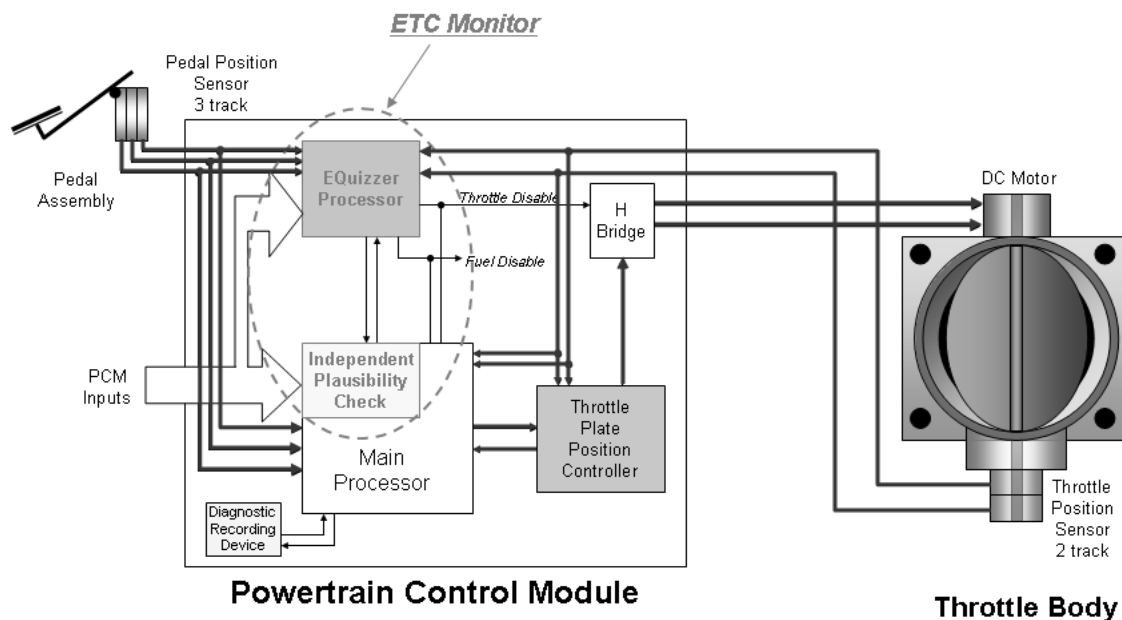

Gen 3 / Gen 4 ETC System

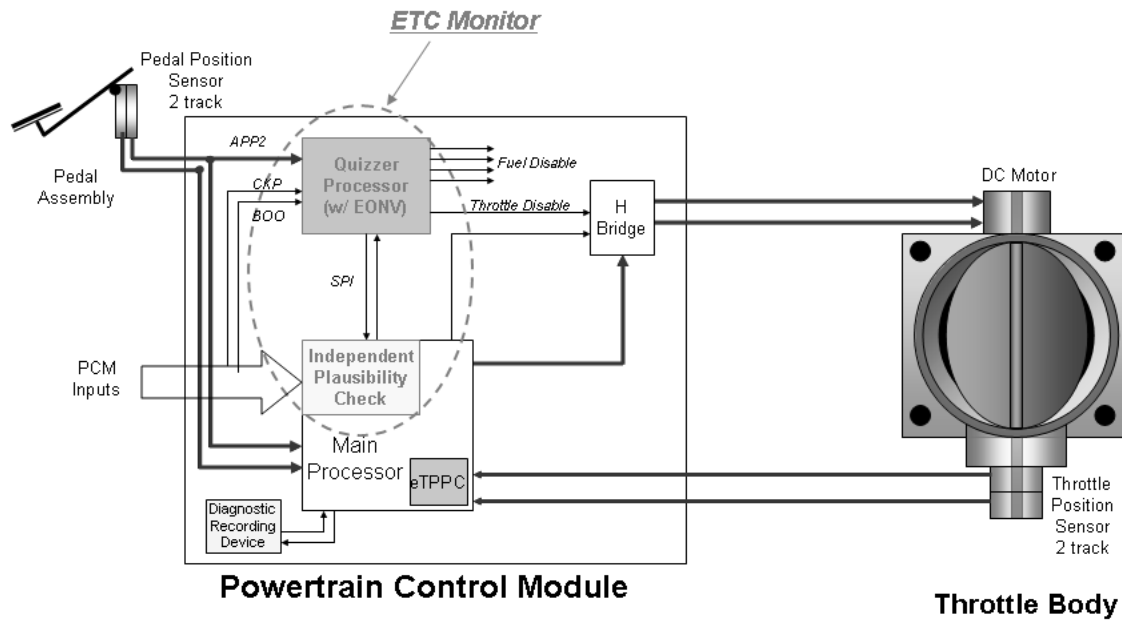

Because safety is a major concern with ETC systems, a complex safety monitor strategy (hardware and software) was developed. The monitor system is distributed across two processors: the main powertrain control processor and a monitoring processor called a Quizzer processor.

The primary monitoring function is performed by the Independent Plausibility Check (IPC) software, which resides on the main processor. It is responsible for determining the driver-demanded torque and comparing it to an estimate of the actual torque delivered. If the generated torque exceeds driver demand by specified amount, the IPC takes appropriate mitigating action.

Since the IPC and main controls share the same processor, they are subject to a number of potential, common-failure modes. Therefore, the Quizzer processor was added to redundantly monitor selected PCM inputs and to act as an intelligent watchdog and monitor the performance of the IPC and the main processor. If it determines that the IPC function is impaired in any way, it takes appropriate Failure Mode and Effects Management (FMEM) actions.

ETC System Failure Mode and Effects Management:

Effect	Failure Mode
No Effect on Drivability	A loss of redundancy or loss of a non-critical input could result in a fault that does not affect drivability. The Wrench light will turn on, but the throttle control and torque control systems will function normally.
RPM Guard w/ Pedal Follower	In this mode, torque control is disabled due to the loss of a critical sensor or PCM fault. The throttle is controlled in pedal-follower mode as a function of the pedal position sensor input only. A maximum allowed RPM is determined based on pedal position (RPM Guard.) If the actual RPM exceeds this limit, spark and fuel are used to bring the RPM below the limit. The wrench light and the MIL are turned on in this mode and an ETC component causal code is set. EGR, VCT, and IMRC outputs are set to default values.
RPM Guard w/ Default Throttle	In this mode, the throttle plate control is disabled due to the loss of Throttle Position, the Throttle Plate Position Controller, or other major ETC system fault. A default command is sent to the (e)TPPC, or the H-bridge is disabled. Depending on the fault detected, the throttle plate is controlled or springs to the default (limp home) position. A maximum allowed RPM is determined based on pedal position (RPM Guard.) If the actual RPM exceeds this limit, spark and fuel are used to bring the RPM below the limit. The wrench light and the MIL are turned on in this mode and an ETC component causal code is set. EGR, VCT, and IMRC outputs are set to default values.
RPM Guard w/ Forced High Idle (Gen 2 only)	This mode is caused by the loss of 2 or 3 pedal position sensor inputs due to sensor, wiring, or PCM faults. The system is unable to determine driver demand, and the throttle is controlled to a fixed high idle airflow. There is no response to the driver input. The maximum allowed RPM is a fixed value (RPM Guard.) If the actual RPM exceeds this limit, spark and fuel are used to bring the RPM below the limit. The wrench light and the MIL are turned on in this mode and a P2104 is set. EGR, VCT, and IMRC outputs are set to default values.
SLOWE / BOA (Gen3 / Gen4 only)	This mode is caused by the loss of 1 or 2 pedal position sensor inputs due to sensor, wiring, or PCM faults. For a single sensor fault, driver demand is rate limited based on input from the remaining good sensor. For a dual sensor fault, driver demand is ramped to a fixed pedal position (high idle RPM) and there is no response to the driver input. If the brake pedal is applied for either a single or dual sensor fault, the engine returns to a normal idle RPM. The wrench light is turned on in this mode, and an accelerator pedal sensor causal code is set.
Shutdown (Gen2 only)	If a significant processor fault is detected, the monitor will force vehicle shutdown by disabling all fuel injectors. The wrench light is turned on in this mode and a P2105 is set. Note: Vehicle shutdown does not increase emissions; therefore the MIL is not required to be illuminated for this fault.
	Note: The wrench light illuminates or an ETC message is displayed on the message center immediately. The MIL illuminates after 2 driving cycles.

Accelerator and Throttle Position Sensor Inputs**On-demand KOEO / KOER Sensor Check Operation:**

DTCs	P1124 – TP A out of self-test range (non-MIL) [Gen3 / Gen4 only] P1575 – APP out of self-test range (non-MIL) [Gen3 / Gen4 only]
Monitor execution	On-demand
Monitor Sequence	None
Sensors OK	not applicable
Monitoring Duration	< 1 seconds to register a malfunction

Accelerator Pedal Position Sensor Check Operation:

DTCs	P2122, P2123 – APP D circuit continuity (wrench light, non-MIL) P2121 – APP D range/performance (wrench light, non-MIL) [Gen2 only] P2127, P2128 – APP E circuit continuity (wrench light, non-MIL) P2126 – APP E range/performance (wrench light, non-MIL) [Gen2 only] P2132, P2133 – APP F circuit continuity (wrench light, non-MIL) [Gen2 only] P2131 – APP F range/performance (wrench light, non-MIL) [Gen2 only] P2138 – APP D/E circuit disagreement (wrench light, non-MIL) [Gen3 / Gen4 only]
Monitor execution	continuous
Monitor Sequence	none
Sensors OK	not applicable
Monitoring Duration	< 1 seconds to register a malfunction

APP sensor check malfunction thresholds:

Circuit continuity - Voltage < 0.25 volts or voltage > 4.75 volts
Range/performance – disagreement between sensors > 1.1 degrees

Throttle Position Sensor Check Operation:

DTCs	P0122, P0123 – TP A circuit continuity (MIL, wrench light) P0222, P0223 – TP B circuit continuity (MIL, wrench light) P2135 – TP A / TP B correlation (non-MIL, wrench light) P0121 – TP A range/performance (non-MIL) [Gen2 only] P0221 – TP B range/performance (non-MIL) [Gen2 only]
Monitor execution	Continuous
Monitor Sequence	None
Sensors OK	not applicable
Monitoring Duration	< 1 seconds to register a malfunction

TP sensor check malfunction thresholds:

Circuit continuity - Voltage < 0.25 volts or voltage > 4.75 volts
Correlation and range/performance – disagreement between sensors > 7 degrees

Electronic Throttle Monitor

Electronic Throttle Monitor Operation:	
DTCs	<p>P2106 – ETC FMEM – forced limited power; sensor fault: MAF, one TP, CKP, TSS, OSS, stuck throttle, throttle actuator circuit fault (MIL, wrench light) [Gen2 only]</p> <p>P2110 – ETC FMEM – forced limited rpm; two TPs failed; TPPC detected fault (MIL, wrench light) [Gen2 only]</p> <p>P2104 – ETC FMEM – forced idle, two or three pedal sensors failed (MIL, wrench light) [Gen2 only]</p> <p>P2105 – ETC FMEM – forced engine shutdown; Quizzer detected fault (non-MIL, wrench light) [Gen2 only]</p> <p>U0300 – ETC software version mismatch, IPC, Quizzer or TPPC (Non-MIL, wrench light for Gen2; MIL, wrench light for Gen3 / Gen4)</p> <p>P0600 – Serial Communication Link (Non-MIL, wrench light for Gen2; MIL, wrench light for Gen3 / Gen4)</p> <p>P060A – Internal control module monitoring processor performance (Non-MIL, wrench light for Gen2; MIL, wrench light for Gen3 / Gen4)</p> <p>P060B – Internal control module A/D processing performance (MIL, wrench light)</p> <p>P060C – Internal control module main processor performance (MIL, wrench light)</p> <p>P060D – Internal control module accelerator pedal performance (non-MIL) [Gen3 / Gen4 only]</p> <p>P061B – Internal control module torque calculation performance (MIL, wrench light)</p> <p>P061C – Internal control module engine rpm performance (MIL, wrench light)</p> <p>P061D – Internal control module engine air mass performance (MIL, wrench light)</p> <p>P061F – Internal control module throttle actuator controller performance (MIL, wrench light for Gen2; non-MIL for Gen3 / Gen4)</p> <p>P062C – Internal control module vehicle speed performance (MIL, wrench light) [Gen2 only]</p> <p>P1674 – Internal control module software corrupted (Non-MIL, wrench light for Gen2; MIL, wrench light for Gen3 / Gen4)</p>
Monitor execution	Continuous
Monitor Sequence	None
Sensors OK	not applicable
Monitoring Duration	< 1 seconds to register a malfunction

Throttle Plate Position Controller (TPPC) Outputs

The purpose of the TPPC is to control the throttle position to the desired throttle angle. The Gen2 ETC system has a separate chip embedded in the PCM. The Gen3 / Gen4 ETC systems have the eTPPC function integrated in the main PCM processor.

For the stand alone TPPC, the desired throttle angle is communicated from the main CPU via a 312.5 Hz duty cycle signal. The TPPC interprets the duty cycle signal as follows:

0% <= DC < 4% - Out of range, limp home default position.

4% <= DC < 6% - Commanded default position, closed.

6% <= DC < 7% - Commanded default position. Used for key-on, engine off.

7% <= DC < 8% - Ice Breaker Mode.

8% <= DC < 10% - Closed against hard-stop. Used to learn zero throttle angle position (hard-stop) after key-up

10% <= DC <=92% - Normal operation, between 0 degrees (hard-stop) and 82%, 10% duty cycle = 0 degrees throttle angle, 92% duty cycle = 82 degrees throttle angle.

92% < DC <= 96% - Wide Open Throttle, 82 to 86 degrees throttle angle.

96% < DC <= 100% - Out of Range, limp home default position

The desired angle is relative to the hard-stop angle. The hard-stop angle is learned during each key-up process before the main CPU requests the throttle plate to be closed against the hard-stop. The output of the (e)TPPC is a voltage request to the H-driver (also in PCM). The H driver is capable of positive or negative voltage to the Electronic Throttle Body Motor.

Throttle Plate Controller and Actuator Operation:

DTCs	<p>P2107 – processor test (MIL, wrench light)</p> <p>P2111 – throttle actuator system stuck open (MIL, wrench light)</p> <p>P2112 – throttle actuator system stuck closed (MIL, wrench light)</p> <p>P2100 – throttle actuator circuit open, short to power, short to ground (non-MIL, wrench light) [Gen2 only]</p> <p>P2101 – throttle actuator range/performance test (MIL, wrench light)</p> <p>P2072 – throttle body ice blockage (non-MIL) [Gen2 only]</p> <p>P115E – throttle actuator airflow trim at max limit (non-MIL)</p>
Monitor execution	Continuous
Monitor Sequence	None
Monitoring Duration	< 5 seconds to register a malfunction

Comprehensive Component Monitor - Engine

Engine Temperature Sensor Inputs

Analog inputs such as Intake Air Temperature (P0112, P0113), Engine Coolant Temperature (P0117, P0118), Cylinder Head Temperature (P1289, P1290), Mass Air Flow (P0102, P0103) and Throttle Position (P0122, P0123, P1120), Fuel Temperature (P0182, P0183), Engine Oil Temperature (P0197, P0198), Fuel Rail Pressure (P0192, P0193) are checked for opens, shorts, or rationality by monitoring the analog -to-digital (A/D) input voltage.

Engine Coolant Temperature Sensor Check Operation:

DTCs	P0117 (low input), P0118 (high input)
Monitor execution	continuous
Monitor Sequence	None
Sensors OK	not applicable
Monitoring Duration	5 seconds to register a malfunction

Typical ECT sensor check malfunction thresholds:

Voltage < 0.244 volts or voltage > 4.96 volts

The ECT rationality test checks to make sure that ECT is not stuck in a range that causes other OBD to be disabled. If after a long (6 hour) soak, ECT is very high (> 230 °F) and is also much higher than IAT at start, it is assumed that ECT is stuck high. If after a long (6 hour) soak, ECT is stuck midrange between 175 °F (typical thermostat monitor threshold temperature) and 230 °F, it is assumed that ECT is stuck mid range.

ECT Sensor Rationality Check Operation:

DTCs	P0116 (ECT stuck high or midrange)
Monitor execution	Once per driving cycle
Monitor Sequence	None
Sensors OK	ECT, CHT, IAT
Monitoring Duration for stuck high	On first valid sample after key on (engine does not have to start)
Monitoring Duration for stuck midrange	5 seconds to register a malfunction

Typical ECT Sensor Rationality check entry conditions:

Entry Condition	Minimum	Maximum
Engine-off time (soak time)	360 min	
Difference between ECT and IAT (stuck high only)		50 deg
Engine Coolant Temperature for stuck high condition	230 °F	
Engine Coolant Temperature for stuck midrange condition	175 °F	230 °F

Typical ECT Sensor Rationality check malfunction thresholds:

ECT stuck high after first valid sample OR ECT stuck midrange for > 5 seconds

Currently, vehicles use either an ECT sensor or CHT sensor, not both. The CHT sensor measures cylinder head metal temperature as opposed to engine coolant temperature. At lower temperatures, CHT temperature is equivalent to ECT temperature. At higher temperatures, ECT reaches a maximum temperature (dictated by coolant composition and pressure) whereas CHT continues to indicate cylinder head metal temperature. If there is a loss of coolant or air in the cooling system, the CHT sensor will still provides an accurate measure of cylinder head metal temperature. If a vehicle uses a CHT sensor, the PCM software calculates both CHT and ECT values for use by the PCM control and OBD systems.

Cylinder Head Temperature Sensor Check Operation:	
DTCs	P1289 (high input), P1290 (low input), P1299 (fail-safe cooling activated)
Monitor execution	continuous
Monitor Sequence	none
Sensors OK	not applicable
Monitoring Duration	5 seconds to register a malfunction

Typical CHT sensor check malfunction thresholds:	
Voltage < 0.244 volts or voltage > 4.96 volts	
For P1299, MIL illuminates immediately if CHT > 270 ° Fuel shut-off is activated to reduce engine and coolant temperature	

Intake Air Temperature Sensor Check Operation:	
DTCs	P0112 (low input), P0113 (high input)
Monitor execution	continuous
Monitor Sequence	none
Sensors OK	not applicable
Monitoring Duration	5 seconds to register a malfunction

Typical IAT sensor check malfunction thresholds:	
Voltage < 0.244 volts or voltage > 4.96 volts	

Engine Oil Temperature Sensor Check Operation:	
DTCs	P0197 (low input), P0198 (high input)
Monitor execution	continuous
Monitor Sequence	none
Sensors OK	not applicable
Monitoring Duration	5 seconds to register a malfunction

Typical EOT sensor check malfunction thresholds:	
Voltage < 0.20 volts or voltage > 4.96 volts	

ECT, IAT, EOT Temperature Sensor Transfer Function		
Volts	A/D counts in PCM	Temperature, degrees F
4.89	1001	-40
4.86	994	-31
4.81	983	-22
4.74	970	-13
4.66	954	-4
4.56	934	5
4.45	910	14
4.30	880	23
4.14	846	32
3.95	807	41
3.73	764	50
3.50	717	59
3.26	666	68
3.00	614	77
2.74	561	86
2.48	508	95
2.23	456	104
1.99	407	113
1.77	361	122
1.56	319	131
1.37	280	140
1.20	246	149
1.05	215	158
0.92	188	167
0.80	165	176
0.70	144	185
0.61	126	194
0.54	110	203
0.47	96	212
0.41	85	221
0.36	74	230
0.32	65	239
0.28	57	248
0.25	51	257
0.22	45	266
0.19	40	275
0.17	35	284
0.15	31	293
0.14	28	302

The Cylinder Head Temp Sensor uses a switchable input circuit to create two transfer functions for cold and hot range temperatures

CHT Temperature Sensor Transfer Function, Cold End		
Volts	A/D counts in PCM	Temperature, degrees F
4.899	1002	-40
4.861	995	-31
4.812	985	-22
4.75	972	-14
4.671	956	-4
4.572	936	4
4.452	911	14
4.309	882	22
4.14	847	32
3.95	808	40
3.737	765	48
3.508	717	58
3.26	666	68
3.00	614	77
2.738	560	87
2.478	507	96
2.226	455	105
1.985	406	114
1.759	360	122
1.551	317	132
1.362	279	141
1.193	244	149
1.043	213	159
0.91	186	168
0.794	162	176
0.693	142	186
0.604	124	194
0.528	108	203
0.462	95	204

CHT Temperature Sensor Transfer Function, Hot End		
Volts	A/D counts in PCM	Temperature, degrees F
4.235	866	168
4.119	843	168
3.993	817	176
3.858	789	185
3.714	760	194
3.563	729	203
3.408	697	212

3.244	664	221
3.076	629	230
2.908	595	239
2.740	561	248
2.575	527	257
2.411	493	266
2.252	461	275
2.099	430	284
1.953	400	294
1.813	371	303
1.680	344	312
1.556	318	320
1.439	294	329
1.329	272	338
1.228	251	347
1.133	232	356
1.046	214	366
0.965	197	375
0.891	182	383
0.822	168	392
0.760	155	401
0.701	144	408
0.648	133	415
0.599	123	422
0.555	113	428
0.513	105	433
0.476	97	438
0.441	90	442
0.409	84	447
0.380	78	450
0.353	72	454
0.328	67	457
0.306	63	460
0.285	58	463
0.265	54	465
0.248	51	468
0.231	47	470
0.216	44	472
0.202	41	474
0.190	39	475
0.178	36	477
0.167	34	478
0.156	32	480

IAT Rationality Test

The IAT rationality test determines if the IAT sensor is producing an erroneous temperature indication within the normal range of IAT sensor input.

The IAT sensor rationality test is run only once per power-up. The IAT sensor input is compared to the CHT sensor input (ECT sensor input on some applications) at key-on after a long (6 hour) soak. If the IAT sensor input and the CHT (ECT) sensor input agree within a tolerance (+/- 30 deg F), no malfunction is indicated and the test is complete. If the IAT sensor input and the CHT (ECT) sensor input differ by more than the tolerance, the vehicle must be driven over 35 mph for 5 minutes to confirm the fault. This is intended to address noise factors like sun load that can cause the IAT sensor to indicate a much higher temperature than the CHT (ECT) sensor after a long soak. Driving the vehicle attempts to bring the IAT sensor reading within the test tolerance. If the IAT sensor input remains outside of the tolerance after the vehicle drive conditions have been met, the test indicates a malfunction and the test is complete.

In addition to the start-up rationality check, an IAT "Out of Range" check is also performed. The test continuously checks to see if IAT is greater than the "IAT Out of Range High threshold", approximately 150 deg F. In order to prevent setting false DTC during extreme ambient or vehicle soak conditions, the same count up/count down timer used for the IAT startup rationality test is used to validate the fault. If IAT is greater than 150 deg F and vehicle speed is greater than ~ 40 mph for 250 seconds then set a P0111.

Either the IAT startup rationality test or the IAT Out of Range High test can set a P0111 DTC. The logic is designed so that either fault can trigger a "two-in-a-row" P0111 MIL, however, both faults must be OK before the P0111 DTC is cleared.

Block heater detection results in a no-call.

Intake Air Temperature Sensor Range/Performance Check Operation:	
DTCs	P0111 (range/performance)
Monitor execution	Once per driving cycle, at start-up
Monitor Sequence	None
Sensors OK	ECT/CHT, IAT, VSS
Monitoring Duration	Immediate or up to 30 minutes to register a malfunction

Typical Intake Air Temperature Sensor Range/Performance Entry Conditions		
Entry condition	Minimum	Maximum
Engine off (soak) time	6 hours	
Battery Voltage	11.0 Volts	
Time since engine start (if driving req'd)		30 min
Vehicle speed (if driving req'd)	40 mph	
Time above minimum vehicle speed (if driving req'd)	5 min	
IAT - ECT at start (block heater inferred)	-30 °F	-90 °F

Typical IAT sensor check malfunction thresholds:
IAT and ECT/CHT error at start-up > +/-30 deg F

Intake Air Temperature Sensor Out of Range High Check Operation:	
DTCs	P0111 (Out of Range High)
Monitor execution	Continuous
Monitor Sequence	None
Sensors OK	ECT/CHT, IAT, VSS
Monitoring Duration	250 seconds to register a malfunction

Typical Intake Air Temperature Sensor Out of Range high Entry Conditions		
Entry condition	Minimum	Maximum
Engine off (soak) time	6 hours	
Battery Voltage	11.0 Volts	
Vehicle speed	40 mph	
Time above minimum vehicle speed (if driving req'd)	5 min	

Typical IAT Sensor Out of Range High check malfunction thresholds:
IAT > 150 deg F

The IAT rationality test employs alternate statistical MIL illumination. This protocol allows up to 6 trips before MIL illumination based on the magnitude of the measured error. The greater the error the fewer number of trips before a DTC will be indicated. In the case of the IAT rationality test the measured error is the difference between the IAT input and the CHT (ECT) input.

The error space is divided into bands. Each band represents a range of error. There are two bands for each of; 5 trips to pending DTC, 4 trips to pending DTC, 3 trips to pending DTC, 2 trips to pending DTC and 1 trip to pending DTC. There are two bands for each because there is one band for positive error and one band for negative error of the same magnitude range.

Counters are maintained that keep track of how many trips a malfunction has occurred within each band. When a sufficient number of trips with a malfunction has been achieved in any band, a P0111 DTC will be set.

If an IAT error, trip to trip, remains just above the IAT-out-of-range error threshold, it will take 6 trips to illuminate the MIL. If the IAT-out-of-range error, trip to trip, is much larger (80 deg F), the MIL will illuminate in the standard 2 trips.

Note that immediately after an KAM clear/battery disconnect, the MIL will be set after two trips regardless of the amount the IAT error exceeds the threshold.

	80	2 Trip MIL		
	75	3 Trip MIL		
	65	4 Trip MIL		
	50	5 Trip MIL		
	30	6 Trip MIL		
IAT - ECT at start (deg F)	0	No Fault		
	-30	6 Trip MIL	} No Call Block Heater	
	-50	5 Trip MIL		
	-65	4 Trip MIL		
	-75	3 Trip MIL		
	-80	2 Trip MIL		

Fuel Rail Pressure Sensor

Fuel Rail Pressure Sensor Check Operation:	
DTCs	P0192 (low input), P0193 (high input)
Monitor execution	continuous
Monitor Sequence	None
Sensors OK	not applicable
Monitoring Duration	8 seconds to register a malfunction

Typical FRP sensor check malfunction thresholds:
Voltage < 0.049 volts or voltage > 4.88 volts

Fuel Rail Pressure Sensor Transfer Function		
FRP volts = [Vref * (4 * Fuel Pressure / 70) + 0.50] / 5.00		
Volts	A/D counts in PCM	Pressure, psi
4.85	993	76.125
4.50	922	70
4.00	820	61.25
3.50	717	52.5
3.00	614	43.75
2.50	512	35
2.00	410	26.25
1.50	307	17.5
1.00	205	8.75
0.50	102	0
0.15	31	-6.125

The FRP range/performance test checks to make sure that fuel rail pressure can be properly controlled by the electronic returnless fuel system. The FPS sensor is also checked for in-range failures that can be caused by loss of Vref to the sensor. Note that the FRP is referenced to manifold vacuum (via a hose) while the fuel rail pressure sensor is not referenced to manifold vacuum. It uses gage pressure. As a result, a mechanical gage in the fuel rail will display a different pressure than the FPR PID on a scan tool. The scan tool PID will read higher because of manifold vacuum.

FRP Range/Performance Check Operation:	
DTCs	P0191 (FRP range/performance), P1090 (stuck in range)
Monitor execution	Continuous
Monitor Sequence	None
Sensors OK	FRP
Monitoring Duration	8 seconds to register a malfunction

Typical FRP Sensor Range/Performance check entry conditions:		
Entry Condition	Minimum	Maximum
Demand pressure reasonable	35 psig	60 psig
Fuel level	15%	

Typical FRP Range/Performance check malfunction thresholds:
Fuel pressure error (demand – actual pressure) > 20 psig

Typical FRP Sensor Stuck check entry conditions:		
Entry Condition	Minimum	Maximum
FRP sensor input	0 psig	46 psig
FRP input not moving		1 psig / sec

Typical FRP Stuck check malfunction thresholds:
Fuel pressure error (demand – actual pressure) > 5 psig

Throttle Position Sensor

Throttle Position Sensor Check Operation:	
DTCs	P0122 (low input), P0123 (high input), P1120 (closed throttle too low)
Monitor execution	continuous
Monitor Sequence	none
Sensors OK	not applicable
Monitoring Duration	5 seconds to register a malfunction

Typical TP sensor check malfunction thresholds:
Voltage < 0.20 volts or voltage > 4.80 volts or voltage < 0.488

Mass Air Flow Sensor

MAF Sensor Check Operation:	
DTCs	P0102 (low input), P0103 (high input)
Monitor execution	continuous
Monitor Sequence	none
Sensors OK	not applicable
Monitoring Duration	5 seconds to register a malfunction

Typical MAF sensor check malfunction thresholds:
Voltage < 0.244 volts and engine running or voltage > 4.785 volts engine rpm < 4,000 rpm

MAF/TP Rationality Test

The MAF and TP sensors are cross-checked to determine whether the sensor readings are rational and appropriate for the current operating conditions. (P1121/P0068)

MAF/TP Rationality Check Operation:	
DTCs	P1121 or P0068
Monitor execution	Continuous
Monitor Sequence	None
Sensors OK	
Monitoring Duration	3 seconds within test entry conditions

Typical MAF/TP rationality check entry conditions:		
Entry Condition	Minimum	Maximum
Engine RPM	1000 rpm	minimum of 3800 rpm
Engine Coolant Temp	100 °F	

Typical MAF/TP rationality check malfunction thresholds:
Load > 60% and TP < 2.4 volts or Load < 30% and TP > 2.4 volts

5 Volt Sensor Reference Voltage Check:	
DTCs	P0642 (low input), P0643 (high input)
Monitor execution	continuous
Monitor Sequence	None
Sensors OK	not applicable
Monitoring Duration	5 seconds to register a malfunction

Typical FRP sensor check malfunction thresholds:
Voltage < 3.5 volts or voltage > 6.5 volts

Miscellaneous CPU Tests

Loss of Keep Alive Memory (KAM) power (a separate wire feeding the PCM) results in a P1633 DTC and immediate MIL illumination.

Vehicles that require tire/axle information and VIN to be programmed into the Vehicle ID block (VID) will store a P1639 if the VID block is not programmed or corrupted.

Additional DTCs will be stored to indicate various internal PCM hardware malfunctions:

P0602 - Powertrain Control Module Programming Error indicates that the Vehicle ID block check sum test failed.

P0603 - Powertrain Control Module Keep Alive Memory (KAM) Error indicates the Keep Alive Memory check sum test failed.

P0604 - Powertrain Control Module Random Access Memory (RAM) Error indicates the Random Access Memory read/write test failed.

P0605 - Powertrain Control Module Read Only Memory (ROM) Error indicates a Read Only Memory check sum test failed.

P0607 - Powertrain Control Module Performance indicates incorrect CPU instruction set operation, or excessive CPU resets.

P06B8 - Internal Control Module Non-Volatile Random Access Memory (NVRAM) Error indicates Permanent DTC check sum test failed

The PCM "engine off" or "soak" timer is tested to ensure that it is functional. The value of engine coolant temperature decays after the engine is turned off. This decay is modeled as a function of ECT, IAT and soak time. If, during a cold start, (difference between ECT and IAT is low), the actual ECT at start is much lower than the predicted ECT at start, it means that the soak timer is not functioning and a P0606 DTC is stored. (If the timer fails, it will read zero seconds and the model will predict that ECT will be the same temperature as when the engine was last turned off.)

Ignition System Tests

EDIS Ignition

The EDIS system uses a chip to process the 36 (or 40) tooth crankshaft position signal, generate a low data rate PIP signal for the PCM microprocessor and control a 4 or 6 terminal coil pack which fires a pair of spark plugs. One of these sparkplugs is on the compression stroke, while the other is on the exhaust stroke. The EDIS chip can be incorporated within the PCM or in a separate ignition control module. The COP system also uses an EDIS chip in the same way as described above, however, each sparkplug has its own coil which is fired only once on the compression stroke.

The EDIS ignition system is checked by monitoring three ignition signals during normal vehicle operation:

Profile Ignition Pickup (CKP, commonly known as PIP), the timing reference signal derived from the crankshaft 36-tooth wheel and processed by the EDIS chip. PIP is a 50% duty cycle, square wave signal that has a rising edge at 10 deg BTDC.

Camshaft IDentification (CMP, commonly known as CID), a signal derived from the camshaft to identify the #1 cylinder

Ignition Diagnostic Monitor (IDM), a signal that indicates that the primary side of the coil has fired. This signal is received as a digital pulsewidth signal from the EDIS chip. The EDIS chip determines if the current flow to the ignition coil reaches the required current (typically 5.5 Amps for COP, 3.0 to 4.0 Amps for DIS) within a specified time period (typically > 200 microseconds for both COP and DIS). The EDIS chip also outputs status information when the engine is not running.

First, the relationship between successive PIP events is evaluated to determine whether the PIP signal is rational. Too large a change in 3 successive PIP indicates a missing or noisy PIP signal (P0320).

Next, the CMP edge count is compared to the PIP edge count. If the proper ratio of CMP events to PIP events is not being maintained (for example, 1 CMP edge for every 8 PIP edges for an 8-cylinder engine), it indicates a missing or noisy CMP signal (P0340).

Finally, the relationship between IDM edges and PIP edges is evaluated. If there is not an IDM edge (coil firing) for every PIP edge (commanded spark event), the PCM will look for a pattern of failed IDM events to determine which ignition coil has failed. If the ignition coil cannot be identified or if the engine is running and there are no IDM edges, the IDM circuit is malfunctioning (P1351).

Power PC Ignition

New "Power PC" processors no longer use an EDIS chip for ignition signal processing. The signals are now directly processed by the PCM using a special interface chip called a Time Processing Unit or TPU. The 36-tooth crankshaft and camshaft position signals come directly into the TPU. The signals to fire the ignition coil drivers also come from the TPU.

The PowerPC ignition system is checked by monitoring three ignition signals during normal vehicle operation:

CKP, the signal from the crankshaft 36-1-tooth wheel. The missing tooth is used to locate the cylinder pair associated with cylinder # 1 The TPU also generates the Profile Ignition Pickup (PIP) signal, a 50% duty cycle, square wave signal that has a rising edge at 10 deg BTDC.

Camshaft IDentification (CMP, commonly known as CID), a signal derived from the camshaft to identify the #1 cylinder

NOMI, a signal that indicates that the primary side of the coil has achieved the nominal current required for proper firing of the spark plug. This signal is received as a digital signal from the coil drivers to the TPU. The coil drivers determine if the current flow to the ignition coil reaches the required current (typically 5.5

Amps for COP, 3.0 to 4.0 Amps for DIS) within a specified time period (typically > 200 microseconds for both COP and DIS).

First, several relationships are checked on the 36-1 tooth CKP signal. The TPU looks for the proper number of teeth (35 or 39) after the missing tooth is recognized; time between teeth too low (< 30 rpm or > 9,000 rpm); or the missing tooth was not where it was expected to be. If an error occurs, the TPU shuts off fuel and the ignition coils and attempts to resynchronize itself. It takes one revolution to verify the missing tooth, and another revolution to verify cylinder #1 using the CMP input. Note that if a P0320 DTC is set on a vehicle with Electronic Throttle Control, (ETC), the ETC software will also set a P2106.

If the proper ratio of CMP events to PIP events is not being maintained (for example, 1 CMP edge for every 8 PIP edges for an 8-cylinder engine), it indicates a missing or noisy CMP signal (P0340). On applications with Variable Cam Timing (VCT), the CMP wheel has five teeth to provide the VCT system with more accurate camshaft control. The TPU checks the CMP signal for an intermittent signal by looking for CMP edges where they would not be expected to be. If an intermittent is detected, the VCT system is disabled and a P0344 (CMP Intermittent Bank 1) or P0349 (CMP intermittent Bank 2) is set.

Finally, the relationship between NOMI events and PIP events is evaluated. If there is not an NOMI signal for every PIP edge (commanded spark event), the PCM will look for a pattern of failed NOMI events to determine which ignition coil has failed.

CKP Ignition System Check Operation:	
DTCs	P0320 (CKP)
Monitor execution	continuous
Monitor Sequence	none
Sensors OK	
Monitoring Duration	< 5 seconds

Typical CKP ignition check entry conditions:		
Entry Condition	Minimum	Maximum
Engine RPM for CKP	200 rpm	

Typical CKP ignition check malfunction thresholds:	
EDIS:	For PIP: Time between PIP edges: > 350 milliseconds Ratio of current PIP period to last two periods: < 0.75, > 1.75
PowerPC:	Incorrect number of teeth after the missing tooth is recognized, Time between teeth too low (< 30 rpm or > 9,000 rpm) Missing tooth was not where it was expected to be.

CMP Ignition System Check Operation:	
DTCs	P0340 (CMP) P0344 (CMP Intermittent Bank 1) P0349 (CMP Intermittent Bank 2)
Monitor execution	continuous
Monitor Sequence	none
Sensors OK	
Monitoring Duration	< 5 seconds

Typical CMP ignition check entry conditions:		
Entry Condition	Minimum	Maximum
Engine RPM for CMP	200 rpm	

Typical CMP ignition check malfunction thresholds:	
EDIS:	Ratio of PIP events to CMP events: 4:1, 6:1, 8:1 or 10:1 based on engine cyl.
PowerPC:	Ratio of PIP events to CMP events: 4:1, 6:1, 8:1 or 10:1 based on engine cyl. Intermittent CMP signal – CMP signal in unexpected location

Coil Primary Ignition System Check Operation:	
DTCs	P0351 – P0360 (Coil primary)
Monitor execution	Continuous
Monitor Sequence	None
Sensors OK	
Monitoring Duration	< 5 seconds

Typical Coil primary ignition check entry conditions:		
Entry Condition	Minimum	Maximum
Engine RPM for coil primary	200 rpm	Minimum of 3200 rpm
Positive engine torque	Positive torque	

Typical Coil primary ignition check malfunction thresholds:
Ratio of PIP events to IDM or NOMI events 1:1

If an ignition coil primary circuit failure is detected for a single cylinder or coil pair, the fuel injector to that cylinder or cylinder pair will be shut off for 30 seconds to prevent catalyst damage. Up to two cylinders may be disabled at the same time on 6 and 8 cylinder engines and one cylinder is disabled on 4 cylinder engines. After 30 seconds, the injector is re-enabled. If an ignition coil primary circuit failure is again detected, (about 0.10 seconds), the fuel injector will be shut off again and the process will repeat until the fault is no longer present. Note that engine misfire can trigger the same type of fuel injector disablement.

Engine Outputs

The Idle Air Control (IAC) solenoid is checked electrically for open and shorts (P1504 or P0511) and is functionally checked by monitoring the closed loop idle speed correction required to maintain the desired idle rpm. If the proper idle rpm cannot be maintained and the system has a high rpm (+100) or low rpm error (-200) greater than the malfunction threshold, an IAC malfunction is indicated. (P1506 or P0507, P1507 or P0506)

IAC Check Operation:	
DTCs	P1504/P0511 (opens/shorts) P1506/P0507 (functional - overspeed) P1507/P0506 (functional - underspeed)
Monitor execution	once per driving cycle
Monitor Sequence	None
Sensors OK	
Monitoring Duration	30 seconds

Typical IAC functional check entry conditions:		
Entry Condition	Minimum	Maximum
Engine Coolant Temp	150 °F	
Time since engine start-up	30 seconds	
Closed loop fuel	Yes	
Throttle Position (at idle, closed throttle, no dashpot)	Closed	Closed

Typical IAC functional check malfunction thresholds:	
For underspeed error: Actual rpm 100 rpm below target, closed-loop IAC correction > 1 lb/min	
For overspeed error: Actual rpm 200 rpm above target, closed-loop IAC correction < .2 lb/min	

The PCM monitors the "smart" driver fault status bit that indicates either an open circuit, short to power or short to ground.

Injector Check Operation:	
DTCs	P0201 through P0210 (opens/shorts)
Monitor execution	Continuous within entry conditions
Monitor Sequence	None
Monitoring Duration	10 seconds

Typical injector circuit check entry conditions:		
Entry Condition	Minimum	Maximum
Battery Voltage	11.0 volts	
Engine Coolant Temp		240 °F
Intake Air Temp		150 °F

Electronic Returnless Fuel Systems (ERFS) utilize a Fuel Pump Driver Module (FPDM) to control fuel pressure. The PCM uses a Fuel Rail Pressure Sensor (FRP) for feedback. The PCM outputs a duty cycle to the FPDM to maintain the desired fuel rail pressure. During normal operation, the PCM will output a FP duty cycle from 5% to 51%. The FPDM will run the fuel pump at twice this duty cycle, e.g. if the PCM outputs a 42% duty cycle, the FPDM will run the fuel pump at 84%. If the PCM outputs a 75% duty cycle, the FPDM will turn off the fuel pump.

The FPDM returns a duty cycled diagnostic signal back to the PCM on the Fuel Pump Monitor (FPM) circuit to indicate if there are any faults in the FPDM.

If the FPDM does not output any diagnostic signal, (0 or 100% duty cycle), the PCM sets a P1233 DTC. This DTC is set if the FPDM loses power. This can also occur if the Inertia Fuel Switch is tripped.

If the FPDM outputs a 25% duty cycle, it means that the fuel pump control duty cycle is out of range. This may occur if the FPDM does not receive a valid control duty cycle signal from the PCM. The FPDM will default to 100% duty cycle on the fuel pump control output. The PCM sets a P1235 DTC.

If the FPDM outputs a 75% duty cycle, it means that the FPDM has detected an open or short on the fuel pump control circuit. The PCM sets a P1237 DTC.

If the FPDM outputs a 50% duty cycle, the FPDM is functioning normally.

Fuel Pump Driver Module Check Operation:	
DTCs	P1233 – FPDM disabled or offline P1235 – Fuel pump control out of range P1237 – Fuel pump secondary circuit
Monitor execution	Continuous, voltage > 11.0 volts
Monitor Sequence	None
Monitoring Duration	3 seconds

Some vehicle applications (2.3L Ranger) use an electric thermostat heater. These vehicles use a high temperature thermostat (220 °F versus 192 °F) to achieve faster warm-up times. The heater circuit can be energized by the PCM whenever additional cooling is required. (The PCM energizes the heater based primarily on ECT/CHT, but can allow for additional cooling based on inputs from rpm, load, IAT and TFT.) The heat generated by the heater causes the thermostat to open at a lower temperature than the rated temperature of the thermostat (up to 50 °F lower), thereby, providing additional engine and transmission cooling. The PCM duty cycles the heater output at 100% to open the thermostat, 70% to keep it open and 0% to provide rated thermostat function. The PCM monitors the "smart" driver fault status bit that indicates either an open circuit, short to power or short to ground. If the heater circuit fails such that it is always off, the vehicle can run hotter than normal. If the heater fails such that it is always on, the vehicle may also fail the thermostat test (P0125/P0128).

Thermostat Heater Check Operation:	
DTCs	P1432 or P0597 (opens/shorts)
Monitor execution	Continuous at 0 and 100% duty cycle
Monitor Sequence	None
Monitoring Duration	5 seconds

Typical thermostat heater check entry conditions:		
Entry Condition	Minimum	Maximum
Battery Voltage	11.0 volts	

There are several different styles of hardware used to control airflow within the engine air intake system. In general, the devices are defined based on whether they control in-cylinder motion (charge motion) or manifold dynamics (tuning).

Systems designed to control charge motion are defined to be Intake Manifold Runner Controls. IMRC systems generally have to modify spark when the systems are active because altering the charge motion affects the burn rate within the cylinder.

Systems designed to control intake manifold dynamics or tuning are defined to be Intake Manifold Tuning Valves. IMTV systems generally do not require any changes to spark or air/fuel ratio because these systems only alter the amount of airflow entering the engine.

Intake Manifold Runner Control Systems

The Intake Manifold Runner Control (IMRC) consists of a remote mounted, electrically motorized actuator with an attaching cable for each housing on each bank. Some applications will use one cable for both banks. The cable or linkage attaches to the housing butterfly plate levers. (The Focus IMRC uses a motorized actuator mounted directly to a single housing without the use of a cable.)

The IMRC housing is an aluminum casting with two intake air passages for each cylinder. One passage is always open and the other is opened and closed with a butterfly valve plate. The housing uses a return spring to hold the butterfly valve plates closed. The motorized actuator houses an internal switch or switches, depending on the application, to provide feedback to the PCM indicating cable and butterfly valve plate position.

Below approximately 3000 rpm, the motorized actuator will not be energized. This will allow the cable to fully extend and the butterfly valve plates to remain closed. Above approximately 3000 rpm, the motorized actuator will be energized. The attaching cable will pull the butterfly valve plates into the open position. (Some vehicles will activate the IMRC near 1500 rpm.)

The Intake Manifold Swirl Control used on the 2.3L Ranger consists of a manifold mounted vacuum actuator and a PCM controlled electric solenoid. The linkage from the actuator attaches to the manifold butterfly plate lever. The IMSC actuator and manifold are composite/plastic with a single intake air passage for each cylinder. The passage has a butterfly valve plate that blocks 60% of the opening when actuated, leaving the top of the passage open to generate turbulence. The housing uses a return spring to hold the butterfly valve plates open. The vacuum actuator houses an internal monitor circuit to provide feedback to the PCM indicating butterfly valve plate position.

Below approximately 3000 rpm, the vacuum solenoid will be energized. This will allow manifold vacuum to be applied and the butterfly valve plates to remain closed. Above approximately 3000 rpm, the vacuum solenoid will be de-energized. This will allow vacuum to vent from the actuator and the butterfly valve plates to open.

IMRC System Check Operation:	
DTCs	P1516/P2014 - IMRC input switch electrical check, Bank 1 P1517/P0219 - IMRC input switch electrical check, Bank 2 P1520/P2008 - IMRC output electrical check P1518/P2004 - IMRC stuck open, electric operated P1537/P2004 – IMRC stuck open, vacuum operated, Bank 1 P1538/P2005 – IMRC stuck open, vacuum operated, Bank 2
Monitor execution	Continuous, after ECT > 40 deg F
Monitor Sequence	None
Sensors OK	
Monitoring Duration	5 seconds

Typical IMRC functional check malfunction thresholds

IMRC plates do not match commanded position (functional)

IMRC switches open/shorted (electrical)

Intake Manifold Tuning Valve Systems

The intake manifold tuning valve (IMTV) is a motorized actuated unit mounted directly to the intake manifold. The IMTV actuator controls a shutter device attached to the actuator shaft. There is no monitor input to the PCM with this system to indicate shutter position.

The motorized IMTV unit will not be energized below approximately 2600 rpm or higher on some vehicles. The shutter will be in the closed position not allowing airflow blend to occur in the intake manifold. Above approximately 2600 rpm or higher, the motorized unit will be energized. The motorized unit will be commanded on by the PCM initially at a 100 percent duty cycle to move the shutter to the open position and then falling to approximately 50 percent to continue to hold the shutter open.

IMTV Check Operation:

DTCs	P1549 or P0660 - IMTV output electrical check (does not illuminate MIL)
Monitor execution	continuous
Monitor Sequence	None
Sensors OK	
Monitoring Duration	5 seconds

Comprehensive Component Monitor - Transmission

General

The MIL is illuminated for all emissions related electrical component malfunctions. For malfunctions attributable to a mechanical component (such as a clutch, gear, band, valve, etc.), some transmissions are capable of not commanding the mechanically failed component and providing the remaining maximum functionality (functionality is reassessed on each power up)- in such case a non-MIL Diagnostic Trouble Code (DTC) will be stored and, if so equipped, a Transmission Control Indicator Light (TCIL) will flash.

Transmission Inputs

Transmission Range Sensor Check Operation:	
DTCs	P0708, P0705 Open/invalid pattern for digital TRS P0707, P0708 Opens/shorts for analog TRS P0705 Out of range signal frequency for PWM TRS P0706, P0707 Low /High duty cycle for PWM TRS P0705 Open/invalid pattern for 4- bit digital TRS – 6HP26, CFT30 P0707, P0708 Opens/shorts for dual analog TRS – F21 P0706 Range/performance for dual analog TRS – F21
Monitor execution	Continuous
Monitor Sequence	None
Sensors OK	
Monitoring Duration	Up to 30 seconds for pattern recognition, 5 seconds for analog faults

Typical TRS check entry conditions:		
Auto Transmission Entry Conditions	Minimum	Maximum
Gear selector position	each position for up to 30 seconds	480 seconds

Typical TRS malfunction thresholds:	
Digital TRS:	Invalid pattern from 3 or 5 digital inputs and/or 1 analog circuit open for 5 seconds
4-bit digital TRS:	Invalid pattern for 200 ms
Analog TRS:	Voltage > 4.8 volts or < 0.2 volts for 5 seconds
Dual analog TRS:	Voltage > 4.84 volts or < 0.127 volts for 200 ms or Sum of both inputs is outside the range of 5.0 volts +/- 0.29 volts for 200 ms
PWM TRS:	Frequency > 160 Hz or < 100 Hz, Duty Cycle > 90% or < 10%

Most vehicle applications no longer have a standalone vehicle speed sensor input. The PCM sometimes obtains vehicle speed information from another module on the vehicle, i.e. ABS module. In most cases, however, vehicle speed is calculated in the PCM by using the transmission output shaft speed sensor signal and applying a conversion factor for axle ratio and tire programmed into the Vehicle ID block. A Vehicle Speed Output pin on the PCM provides the rest of the vehicle with the standard 8,000 pulses/mile signal.

Note: If the Vehicle ID block has not been programmed or has been programmed with an out-of-range (uncertified) tire/axle ratio, a P1639 DTC will be stored and the MIL will be illuminated immediately.

Vehicle Speed Sensor Functional Check Operation:	
DTCs	P0500 – VSS circuit
Monitor execution	Continuous
Monitor Sequence	None
Sensors OK	
Monitoring Duration	30 seconds

Typical VSS functional check entry conditions:		
Auto Transmission Entry Conditions	Minimum	Maximum
Gear selector position	drive	
Engine rpm (above converter stall speed) OR	3000 rpm	
Turbine shaft rpm (if available) OR	1500 rpm	
Output shaft rpm	650 rpm	
Vehicle speed (if available)	15 mph	
Manual Transmission Entry Conditions		
Engine load	50 %	
Engine rpm	2400 rpm	

Typical VSS functional check malfunction thresholds:
Vehicle is inferred to be moving with positive driving torque and VSS is < 1 - 5 mph for 5 seconds

Output Shaft Speed Sensor Functional Check Operation:	
DTCs	P0720 – OSS circuit P0721 – OSS range/performance -F-21, 6HP26 P0722 – OSS no signal P0723 – OSS intermittent/erratic – 6HP26
Monitor execution	Continuous
Monitor Sequence	None
Sensors OK	TSS, Wheel Speed
Monitoring Duration	30 seconds

Typical OSS functional check entry conditions:		
Auto Transmission Entry Conditions	Minimum	Maximum
Gear selector position	drive	
Engine rpm (above converter stall speed) OR	3000 rpm	
Primary Pulley Speed (CFT30) OR	400 rpm	
Turbine shaft rpm (if available) OR	1500 rpm	
Output shaft rpm	300 - 650 rpm	
Vehicle speed (if available)	12.5 - 15 mph	

Typical OSS functional check malfunction thresholds:
Circuit/no signal - vehicle is inferred to be moving with positive driving torque and OSS < 100 to 200 rpm for 5 to 30 seconds
6HP26 Circuit/no signal: open or short circuit for > 0.6 seconds
6HP Range/Performance: > 200 rpm difference between OSS and wheel speed and > 250 rpm difference between OSS and input shaft speed
F21 Range/Performance: TSS, ABS wheel speed and engine rpm correlate properly, but OSS error is greater than 15% for 10 seconds
CFT30 Range/Performance: ABS wheel speed indicates a 6.24 mph difference with OSS calculated wheel speed
6HP26 Intermittent/Erratic: > -1000 rpm instantaneous change with locked torque converter clutch
CFT30 Intermittent/Erratic: > 6000 rpm/sec change

Intermediate Shaft Speed Sensor Functional Check Operation:	
DTCs	P0791 – ISS circuit
Monitor execution	Continuous
Monitor Sequence	None
Sensors OK	
Monitoring Duration	30 seconds

Typical ISS functional check entry conditions:		
Auto Transmission Entry Conditions	Minimum	Maximum
Gear selector position	drive	
Engine rpm (above converter stall speed) OR	3000 rpm	
Turbine shaft rpm (if available) OR	1500 rpm	
Output shaft rpm	650 rpm	
Vehicle speed (if available)	15 mph	

Typical ISS functional check malfunction thresholds:
Vehicle is inferred to be moving with positive driving torque and ISS < 250 rpm for 5 seconds

Turbine Shaft Speed Sensor Functional Check Operation:	
DTCs	P0715 – TSS circuit P0716 – TSS range/performance - F-21, 6HP26, CFT30 P0717 – TSS no signal
Monitor execution	Continuous
Monitor Sequence	None
Sensors OK	OSS, Wheel Speed
Monitoring Duration	30 seconds

Typical TSS functional check entry conditions:		
Auto Transmission Entry Conditions	Minimum	Maximum
Gear selector position	Forward range	
Engine rpm (above converter stall speed) OR	3000 rpm	
Output shaft rpm OR	600 - 650 rpm	
Vehicle speed (if available)	12.5 - 15 mph	

Typical TSS functional check malfunction thresholds:
Circuit/no signal - vehicle is inferred to be moving with positive driving torque and TSS < 200 rpm for 5 – 30 seconds
F21 Range/Performance – OSS, ABS wheel speed and engine rpm correlate properly, but TSS error is greater than 15% for 10 seconds
F21, 6HP26 Circuit/no signal – open or short circuit for > 0.6 seconds
6HP26 Range/Performance - - vehicle is inferred to be moving with positive driving torque and TSS < 20 rpm for 0.6 seconds
CFT30 Intermittent/Erratic: > 11,000 rpm/sec change

Primary Pulley Speed Sensor Functional Check Operation:	
DTCs	P2765 – ISS circuit – CFT30 P2766 – ISS Range/Performance – CFT30
Monitor execution	Continuous
Monitor Sequence	None
Sensors OK	
Monitoring Duration	30 seconds

Typical Primary Pulley functional check entry conditions:		
Entry Conditions	Minimum	Maximum
Gear selector position	drive	
Vehicle speed OR	4 mph	
Engine rpm = Turbine rpm w/converter locked OR	300 rpm	300 rpm
Output shaft rpm	650 rpm	1000 rpm

Typical Primary Pulley functional check malfunction thresholds:
Circuit/no signal: Vehicle is inferred to be moving with positive driving torque and PPS = 0 rpm for .25 seconds or
Intermittent/Erratic: > 7,500 rpm/sec change

Transmission Fluid Temperature Sensor Functional Check Operation:	
DTCs (non-MIL)	P0712, P0713 or P0710 Opens/shorts P1713 Stuck low, P1718 Stuck high, or P0711 Stuck low/high P0714 Intermittent/Erratic – 6HP26
Monitor execution	continuous
Monitor Sequence	none
Sensors OK	ECT substituted if TFT has malfunction TFT inferred from pressure solenoids on CFT30
Monitoring Duration	5 seconds for electrical, 600 seconds for functional check

Typical TFT Stuck Low/High check entry conditions:		
Auto Transmission Entry Conditions	Minimum	Maximum
Engine Coolant Temp (hot or cold, not midrange)	> 100 °F	< 20 °F
Time in run mode	500 – 600 sec	
Time in gear, vehicle moving, positive torque	150 sec	
Vehicle Speed	15 mph	
Time with engine off (cold start) OR	420 min	
Engine Coolant Temp AND Trans Fluid Temp (inferred cold start)		122 °F

Typical TFT malfunction thresholds:
<p>Opens/shorts: TFT voltage <0.05 or > 4.6 volts for 5 – 12 seconds</p> <p>TFT Stuck low/high, i.e. TFT stuck at high temperature or stuck at low temperature):</p> <p>Old Logic (pre 2006 MY):</p> <p style="padding-left: 40px;">< 6 °F rise or fall in TFT after extended vehicle driving</p> <p>New Logic (phase in between 2006 and 2008 MY):</p> <p style="padding-left: 40px;">Stores a fault code if TFT stabilizes (stops increasing if temperature < 70 deg F, stops decreasing if temperature > 225 deg F) before reaching the temperature region where all MIL tests are enabled (70 to 225 deg F). If TFT remains constant (+/- 2 deg F) for approximately 2.5 minutes of vehicle driving outside the 70 to 225 deg F zone a P0711 fault code will be stored. Old logic used to indicate a "pass" for a single delta, and not test until the normal operating region (70-225 deg F) was reached.</p> <p>6HP26 Stuck low/high: > 77 deg F difference between TFT and internal TCM temperature sensor.</p> <p>CFT30 Stuck low/high: > 54 deg F difference between TFT and inferred TFT.</p> <p>6HP26 Intermittent/Erratic check: > 68 deg F change between successive readings</p> <p>CFT30 Intermittent/Erratic Check: > 180 deg F change per second</p> <p>F21 Stuck: < 2 °F rise or fall in TFT after extended vehicle driving</p>

Secondary Pulley Pressure Sensor Check Operation:

DTCs	P0840 Low or high input – CFT30
Monitor execution	Continuous
Monitor Sequence	None
Sensors OK	not applicable
Monitoring Duration	0.200 seconds to register a malfunction

Typical Secondary Pulley pressure sensor check malfunction thresholds:

Voltage < 1.5 volts or voltage > 4.8 volts

Main Pressure Sensor Check Operation:

DTCs	P0845 Low or high input – CFT30
Monitor execution	Continuous
Monitor Sequence	None
Sensors OK	not applicable
Monitoring Duration	0.200 seconds to register a malfunction

Typical Main pressure sensor check malfunction thresholds:

Voltage < 1.5 volts or voltage > 4.8 volts

Transmission Outputs

Shift Solenoid Check Operation:	
DTCs	SS A - P0750 electrical, P1714 ISIG functional, or P0751 mechanical functional P0973, P0974 opens/shorts – 6HP26, F21 P0972 current range – 6HP26 SS B - P0755 electrical, P1715 ISIG functional, or P0756 mechanical functional P0976, P0977 opens/shorts – 6HP26 P0975 current range – 6HP26 SS C - P0760 electrical, P1716 ISIG functional, or P0761 mechanical functional P0979, P0980 opens/shorts – 6HP26, F21 P0978 current range – 6HP26, F21 SS D - P0765 electrical, P1717 ISIG functional, or P0766 mechanical functional P0982, P0983 opens/shorts – 6HP26, F21 P0981 current range – 6HP26, F21 SS E - P0770 electrical, or P0771 mechanical functional P0985, P0986 opens/shorts – 6HP26, F21 P0984 current range – 6HP26, F21 SS F - P0998, P0999 opens/shorts – F21 P0997 current range – F21
Monitor execution	electrical - continuous, functional - during off to on solenoid transitions
Monitor Sequence	None
Sensors OK	
Monitoring Duration	0.5 to 5 seconds for electrical checks, 10 solenoid events for functional check

Typical Shift Solenoid ISIG functional check entry conditions:		
Entry Conditions	Minimum	Maximum
Transmission Fluid Temp	70 °F	225 °F
Throttle position	positive drive torque (actual TP varies)	

Typical Shift Solenoid mechanical functional check entry conditions:

Entry Conditions (with turbine speed)	Minimum	Maximum
Gear ratio calculated	each gear	
Throttle position	positive drive torque	

Typical Shift Solenoid mechanical functional check entry conditions:

Entry Conditions (without turbine speed)	Minimum	Maximum
Rpm drop is obtained	each shift	
Throttle position	positive drive torque	

Typical Shift Solenoid malfunction thresholds:

Electrical circuit check: Output driver feedback circuit does not match commanded driver state for 0.5 – 5.0 seconds

Electrical current check: Feedback current out of range for 0.5 seconds

ISIG functional check: ISIG chip hardware circuit does not detect characteristic current dip and rise produced by solenoid movement.

Mechanical functional check: Actual obtained gear or shift pattern indicates which shift solenoid is stuck on or off.

Gear Ratio Check Operation:	
DTCs	P0731 incorrect gear 1 ratio – 6HP26, F21 P0732 incorrect gear 2 ratio – 6HP26, F21 P0733 incorrect gear 3 ratio – 6HP26, F21 P0734 incorrect gear 4 ratio – 6HP26, F21 P0735 incorrect gear 5 ratio – 6HP26, F21 P0729 incorrect gear 6 ratio – 6HP26, F21 P0736 incorrect reverse ratio – 6HP26 P1700 incorrect neutral ratio – F21
Monitor execution	Continuous, in each gear
Monitor Sequence	None
Sensors OK	TSS, OSS, wheel speed
Monitoring Duration	12 seconds

Typical Forward Gear Ratio check entry conditions:		
Entry Conditions	Minimum	Maximum
Gear selector position	forward range, > 8 seconds	
Engine Torque	100 NM	
Throttle position	10%	
Not shifting	> 0.5 seconds	
Engine/input Speed	550 rpm	
Output Shaft Speed	250 rpm	1350 rpm

Typical Neutral Gear Ratio check entry conditions:		
Entry Conditions	Minimum	Maximum
Gear selector position	forward range, > 1 second	
Absolute value of Engine rpm – Turbine rpm		150 rpm
Output Shaft Speed		500 rpm

Typical Gear Ratio malfunction thresholds:
F21 Forward gear check: > 20% error in commanded ratio for > 12 seconds
F21 Neutral gear check: $TSS > (OSS * Gear\ 1\ ratio) + 400\ rpm$ for > 1 second
6HP26 Forward and reverse gear check: > 400 to 640 rpm difference between calculated input and output shaft speeds for 3 monitoring events

Shift Completion Check Operation:	
DTCs	P0781 incorrect 1-2 shift – 6HP26 P0782 incorrect 2-3 shift – 6HP26 P0783 incorrect 3-4 shift – 6HP26 P0784 incorrect 4-5 shift – 6HP26 P0829 incorrect 5-6 shift – 6HP26
Monitor execution	During up-shifts and down-shifts
Monitor Sequence	None
Sensors OK	TSS, OSS
Monitoring Duration	5 shift events

Typical Shift Completion check entry conditions:		
Entry Conditions	Minimum	Maximum
Gear selector position	forward range	
Transmission Fluid Temp	50 °F	
Engine/input Speed	1200 rpm	
Output Shaft Speed	256 rpm	

Typical Shift Completion malfunction thresholds:	
Up-shift rpm check:	rpm does not drop by > 30 rpm
Down-shift rpm check:	rpm does not increase by > 30 rpm
Up-shift rpm check:	rpm increases (flares) by > 300 rpm

Torque Converter Clutch Check Operation:	
DTCs	P0740, P2763, P2764, P0742, P0743 Opens/shorts P0744 Intermittent – 5R110 P2762 current range – 6HP26, F21 P1740 ISIG functional P1744 mechanical functional - 4R100 P0741 mechanical functional, stuck off P1742 mechanical functional, stuck on – CD4E P2758 mechanical functional, stuck on - F21 P2757 mechanical functional, stuck off - F21
Monitor execution	electrical - continuous, mechanical - during lockup
Monitor Sequence	None
Sensors OK	TSS, OSS
Monitoring Duration	Electrical – 5 seconds, Functional - 5 lock-up events

Typical TCC ISIG functional check entry conditions:		
Entry Conditions	Minimum	Maximum
Transmission Fluid Temp	70 °F	225 °F
Engine Torque	positive drive torque	
Commanded TCC duty cycle for 0 rpm slip	60%	90%

Typical TCC mechanical functional check stuck off entry conditions:		
Entry Conditions	Minimum	Maximum
Throttle Position	steady	
Engine Torque	positive drive torque	
Transmission Fluid Temp	70 °F	225 °F
Commanded TCC duty cycle (0 rpm slip)	60%	100%
Not shifting		

Typical TCC malfunction thresholds:
Electrical circuit check: Output driver feedback circuit does not match commanded driver state for 0.5 – 5.0 seconds
Electrical current check: Feedback current out of range for 0.5 seconds
ISIG functional check: ISIG chip hardware circuit does not detect characteristic current dip and rise produced by solenoid movement.
Mechanical check, stuck off: Slip across torque converter > 100 – 200 rpm or speed ratio < 0.93
Mechanical check, stuck on: Slip across torque converter < 20 rpm with converter commanded off
Mechanical check, stuck on: engine rpm < 100 after drive engagement (engine stall)

Pressure Control Solenoid Check Operation:

DTCs	P1747 or P0962 PC A shorted low P1789 or P0966 PC A shorted low P0797 or P0970 PC C shorted low P0745, P0775, P0795 mechanical functional P0960, P0962, P0963 PC A opens/shorts - 6HP26, F21 P0961 PC A current range – 6HP26, F21 P0964, P0966, P0967 PC B opens/shorts - CFT30 P0968, P0970, P0971 PC C opens/shorts - CFT30
Monitor execution	Continuous
Monitor Sequence	none
Sensors OK	
Monitoring Duration	Electrical: 5 seconds, Mechanical functional: up to 30 seconds

Typical Pressure Control Solenoid mechanical functional check entry conditions:

Entry Conditions	Minimum	Maximum
Gear ratio calculated	each gear	
Transmission Fluid Temperature	70 °F	225 °F
Throttle Position	positive drive torque	

Typical Pressure Control Solenoid malfunction thresholds:

Electrical circuit check: Output driver feedback circuit does not match commanded driver state for 0.5 – 5.0 seconds

Electrical current check: Feedback current out of range for 0.5 seconds

Mechanical functional check: Actual obtained gear pattern indicates Pressure Control solenoid fault

Inductive Signature Chip Communication Check Operation:	
DTCs	P1636 ISIG chip loss of communication
Monitor execution	off-to-on solenoid transitions
Monitor Sequence	none
Sensors OK	
Monitoring Duration	< 100 solenoid events

Typical Inductive Signature Chip Communication Check entry conditions:		
Entry Conditions	Minimum	Maximum
Transmission Fluid Temp	70 °F	225 °F
Solenoid commanded off duration		< 2 seconds

Typical Inductive Signature Communication Chip malfunction thresholds:
Checksum error, chip not responding

Forward Clutch/Reverse Clutch Solenoid Check Operation:	
DTCs	P0900, P0902, P0903 Opens/shorts – CFT30 P0810 functional, sticking – CFT30 P0811 functional, slippage – CFT30
Monitor execution	Continuous
Monitor Sequence	None
Sensors OK	
Monitoring Duration	Electrical: 0.040 seconds, Mechanical functional: 0.500 seconds

Typical Forward Clutch/Reverse Clutch slipping check entry conditions:		
Entry Conditions	Minimum	Maximum
Vehicle Speed OR		0.62 mph
Vehicle Speed	16 mph	
Gear selector	Drive or Reverse	

Typical Forward Clutch/Reverse Clutch stuck check entry conditions:		
Entry Conditions	Minimum	Maximum
Vehicle Speed OR		0.62 mph
Vehicle Speed	16 mph	
Gear selector	Park or Neural	

Typical Forward Clutch/Reverse Clutch Solenoid malfunction thresholds:
Electrical current check: Feedback current out of range for 0.040 seconds
Slipping Check: Turbine Speed is > 100 rpm higher than Pulley Speed for 200 ms.
Stuck Check: Turbine Speed is within 40 rpm of Pulley Speed for 500 ms.

4R75E (RWD) Transmission

4R75E is the replacement for the 4R70W. The 4R75E transmission is essentially a 4R70W with a Turbine Speed Sensor (TSS)

Transmission Inputs

The Digital Transmission Range (DTR) sensor provides a single analog and three digital inputs to the PCM. The PCM decodes the inputs to determine the driver-selected gear position (Park, Rev, Neutral, OD, 2, 1). This input device is checked for opens and invalid input patterns. (P0708 P0705)

The Vehicle Speed Sensor (VSS), Output Shaft Speed (OSS) sensor, and Turbine Speed Sensor (TSS) if equipped, are inputs that are checked for rationality. If the engine rpm is above the torque converter stall speed and engine load is high, it can be inferred that the vehicle must be moving. If there is insufficient output from the VSS sensor, a malfunction is indicated (P0500). If there is insufficient output from the OSS sensor, a malfunction is indicated (P0720). If there is insufficient output from the TSS sensor, a malfunction is indicated (P0715).

Transmission Outputs

Shift Solenoids

The Shift Solenoid (SSA and SSB) output circuits are checked for opens and shorts by the PCM by monitoring the status of a feedback circuit from the output driver (P0750 SSA, P0755 SSB).

All vehicle applications will utilize an inductive signature circuit to monitor the shift solenoids functionally. The ISIG circuit monitors the current signature of the shift solenoid as the solenoid is commanded on. A solenoid that functions properly will show a characteristic decrease in current as the solenoid starts to move. If the solenoid is malfunctioning, the current will not change (P1714 SSA, P1715 SSB). The lack of communication between the ISIG chip and the PCM microprocessor is also monitored (P1636).

Torque Converter Clutch

The Torque Converter Clutch (TCC) output circuit is a duty-cycled output that is checked electrically for opens and shorts by the PCM by monitoring the status of a feedback circuit from the output driver (P0743).

All vehicle applications will utilize an inductive signature circuit to monitor the torque converter clutch. The ISIG circuit monitors the current signature of the TCC solenoid as the solenoid is commanded on. A solenoid that functions properly will show a characteristic decrease in current as the solenoid starts to move. If the solenoid is malfunctioning, the current will not change (P1740). In some applications, the ISIG test is run in conjunction with the other transmission functional tests. The lack of communication between the ISIG chip and the PCM microprocessor is also monitored (P1636).

Electronic Pressure Control

The EPC solenoid is a variable force solenoid that controls line pressure in the transmission. The EPC solenoid has a feedback circuit in the PCM that monitors EPC current. If the current indicates a short to ground (low pressure), engine torque may be reduced to prevent damage to the transmission. (P0962, PCA)

CD4E (FWD) Transmission

Transmission Inputs

The Analog Transmission Range (TR) sensor provides a single analog input to the PCM. The voltage corresponds to the driver-selected gear position (Park, Rev, Neutral, OD, 2, 1). This input is checked for opens and shorts. (P0707, P0708)

The Turbine Shaft Speed (TSS) sensor and Output Shaft Speed (OSS) sensors are analog inputs that are checked for rationality. If the engine rpm is above the torque converter stall speed and engine load is high, it can be inferred that the vehicle must be moving. If there is insufficient output from the TSS sensor, a malfunction is indicated (P0715). If there is insufficient output from the OSS sensor, a malfunction is indicated (P0720).

Transmission Outputs

Shift Solenoids

The Shift Solenoid (SSA and SSB) output circuits are checked for opens and shorts by the PCM by monitoring the status of a feedback circuit from the output driver (P0750 SSA, P0755 SSB).

All vehicle applications will utilize an inductive signature circuit to monitor the shift solenoids functionally. The ISIG circuit monitors the current signature of the shift solenoid as the solenoid is commanded on. A solenoid that functions properly will show a characteristic decrease in current as the solenoid starts to move. If the solenoid is malfunctioning, the current will not change (P1714 SSA, P1715 SSB). The ISIG test runs in conjunction with the other transmission functional tests. The lack of communication between the ISIG chip and the PCM microprocessor is also monitored (P1636).

Torque Converter Clutch

The Torque Converter Clutch (TCC) output circuit is a duty-cycled output that is checked electrically for opens and shorts by the PCM by monitoring the status of a feedback circuit from the output driver (P0743).

The PWM used to control CD4E's TCC does not have sufficient inductive signature, therefore on these applications the TCC solenoid is functionally tested by monitoring converter slip. If the TCC is failed on when commanded off, a P1742 fault code will be stored. If the TCC is failed off when commanded on, a P0741 fault code will be stored.

Electronic Pressure Control

The EPC solenoid is a variable force solenoid that controls line pressure in the transmission. The EPC solenoid has a feedback circuit in the PCM that monitors EPC current. If the current indicates a short to ground (low pressure), engine torque may be reduced to prevent damage to the transmission. (P0962, PCA)

5R44E (RWD) Transmission

Transmission Inputs

The Digital Transmission Range (DTR) sensor provides a single analog and three digital inputs to the PCM. The PCM decodes these inputs to determine the driver-selected gear position (Park, Rev, Neutral, OD, 2, 1).

This input device is checked for opens and invalid input patterns. (P0708 P0705)

The Turbine Shaft Speed (TSS) sensor and Output Speed Sensor (OSS) are inputs that are checked for rationality. Provided one of the two speed sensors has sufficient signal and engine load is high enough and the engine speed is above the torque converter stall speed, it can be inferred that the vehicle must be moving. If there is insufficient output from the TSS sensor, a malfunction is indicated (P0715). If there is insufficient output from the OSS sensor, a malfunction is indicated (P0720).

Transmission Outputs

Shift Solenoids

The Shift Solenoid (SSA, SSB, SSC, and SSD) output circuits are checked for opens and shorts by the PCM by monitoring the status of a feedback circuit from the output driver (P0750 SSA, P0755 SSB, P0760 SSC, and P0765 SSD).

All vehicle applications will utilize an inductive signature circuit to monitor the shift solenoids functionally. The ISIG circuit monitors the current signature of the shift solenoid as the solenoid is commanded on. A solenoid that functions properly will show a characteristic decrease in current as the solenoid starts to move. If the solenoid is malfunctioning, the current will not change (P1714 SSA, P1715 SSB, P1716 SSC, P1717 SSD). The ISIG test runs in conjunction with the other transmission functional tests. The lack of communication between the ISIG chip and the PCM microprocessor is also monitored (P1636).

Torque Converter Clutch

The Torque Converter Clutch (TCC) output circuit is a duty-cycled output that is checked electrically for opens and shorts by the PCM by monitoring the status of a feedback circuit from the output driver (P0743).

These vehicle applications will utilize an inductive signature circuit to monitor the torque converter clutch. The ISIG circuit monitors the current signature of the TCC solenoid as the solenoid is commanded on. A solenoid that functions properly will show a characteristic decrease in current as the solenoid starts to move. If the solenoid is malfunctioning, the current will not change (P1740). The ISIG test is run in conjunction with the other transmission functional tests. The lack of communication between the ISIG chip and the PCM microprocessor is also monitored (P1636).

Electronic Pressure Control Output

The EPC solenoid is a variable force solenoid that controls line pressure in the transmission. The EPC solenoid has a feedback circuit in the PCM that monitors EPC current. If the current indicates a short to ground (low pressure), engine torque may be reduced to prevent damage to the transmission. (P1747, PCA)

5R55E (RWD) Transmission

Transmission Inputs

The Digital Transmission Range (DTR) sensor provides a single analog and three digital inputs to the PCM. The PCM decodes these inputs to determine the driver-selected gear position (Park, Rev, Neutral, OD, 2, 1). This input device is checked for opens and invalid input patterns. (P0708, P0705)

The Turbine Shaft Speed (TSS) and Output Shaft Speed (OSS) sensors are inputs that are checked for rationality. Provided one of the two speed sensors has sufficient signal and engine load is high enough and the engine rpm is above the torque converter stall speed, it can be inferred that the vehicle must be moving. If there is insufficient output from the TSS sensor, a malfunction is indicated (P0715). If there is insufficient output from the OSS sensor, a malfunction is indicated (P0720).

Transmission Outputs

Shift Solenoids

The Shift Solenoid (SSA, SSB, SSC and SSD) output circuits are checked for opens and shorts by the PCM by monitoring the status of a feedback circuit from the output driver (P0750 SSA, P0755 SSB, P0760 SSC, P0765 SSD).

These vehicle applications will utilize an inductive signature circuit to monitor the shift solenoids functionally. The ISIG circuit monitors the current signature of the shift solenoid as the solenoid is commanded on. A solenoid that functions properly will show a characteristic decrease in current as the solenoid starts to move. If the solenoid is malfunctioning, the current will not change (P1714 SSA, P1715 SSB, P1716 SSC, P1717 SSD). The ISIG test is run in conjunction with the other transmission functional tests. The lack of communication between the ISIG chip and the PCM microprocessor is also monitored (P1636).

Torque Converter Clutch

The Torque Converter Clutch (TCC) output circuit is a duty-cycled output that is checked electrically for opens and shorts by the PCM by monitoring the status of a feedback circuit from the output driver (P0743).

These vehicle applications will utilize an inductive signature circuit to monitor the torque converter clutch. The ISIG circuit monitors the current signature of the TCC solenoid as the solenoid is commanded on. A solenoid that functions properly will show a characteristic decrease in current as the solenoid starts to move. If the solenoid is malfunctioning, the current will not change (P1740). The ISIG test runs in conjunction with the other transmission functional tests. The lack of communication between the ISIG chip and the PCM microprocessor is also monitored (P1636).

Electronic Pressure Control Output

The EPC solenoid is a variable force solenoid that controls line pressure in the transmission. The EPC solenoid has a feedback circuit in the PCM that monitors EPC current. If the current indicates a short to ground (low pressure), engine torque may be reduced to prevent damage to the transmission. (P0962, PCA)

5R55S (RWD) Transmission

Transmission Inputs

The Digital Transmission Range (DTR) sensor provides a single analog and three digital inputs to the PCM. The PCM decodes these inputs to determine the driver-selected gear position. This input device is checked for opens and invalid input patterns. (P0708, P0705)

Turbine Shaft Speed (TSS) and Output Shaft Speed (OSS) sensors are analog inputs that are checked for rationality. If the engine rpm is above the torque converter stall speed and engine load is high, it can be inferred that the vehicle must be moving. If there is insufficient output from the TSS sensor, a malfunction is indicated (P0715). If there is insufficient output from the OSS sensor, a malfunction is indicated (P0720).

Transmission Outputs

Shift Solenoids

The Shift Solenoid (SSA, SSB, SSC, SSD) output circuits are checked for opens and shorts by the PCM by monitoring the status of a feedback circuit from the output driver (P0750 SSA, P0755 SSB, P0760 SSC, P0765 SSD).

These vehicle applications will utilize an inductive signature circuit to monitor the shift solenoids functionally. The ISIG circuit monitors the current signature of the shift solenoid as the solenoid is commanded on. A solenoid that functions properly will show a characteristic decrease in current as the solenoid starts to move. If the solenoid is malfunctioning, the current will not change (P1714 SSA, P1715 SSB, P1716 SSC, P1717 SSD). The ISIG test runs in conjunction with the other transmission functional tests. The lack of communication between the ISIG chip and the PCM microprocessor is also monitored (P1636).

Electronic Pressure Control Outputs

The VFS solenoids are variable force solenoids that control line pressure and gear selection in the transmission. The VFS solenoids have a feedback circuit in the PCM that monitors VFS current. If the current indicates a short to ground (low pressure), engine torque may be reduced to prevent damage to the transmission. (P0962, P0966, P0970).

The VFS solenoids are also checked for functionality by utilizing a rationality test that looks at gear ratios. If VFS/shift solenoid electrical faults and shift solenoid ISIG faults are not present, then actual ratios versus expected ratios are used to infer VFS failures. (P0745 PCA, P0775 PCB, P0795 PCC)

Torque Converter Clutch

The Torque Converter Clutch (TCC) output circuit is a duty-cycled output that is checked electrically for opens and shorts by the PCM by monitoring the status of a feedback circuit from the output driver (P0743).

These vehicle applications will utilize an inductive signature circuit to monitor the torque converter clutch. The ISIG circuit monitors the current signature of the TCC solenoid as the solenoid is commanded on. A solenoid that functions properly will show a characteristic decrease in current as the solenoid starts to move. If the solenoid is malfunctioning, the current will not change (P1740). The ISIG test runs in conjunction with the other transmission functional tests. The lack of communication between the ISIG chip and the PCM microprocessor is also monitored (P1636).

Direct One Way Clutch

The Direct One Way Clutch is checked for functionality by utilizing a rationality test that looks at transmission input torque relative to commanded throttle position while in 1st, 3rd, or 4th gear. If a direct one way clutch fault is present, then the transmission will not be able to carry torque at high throttle angles in 1st, 3rd, or 4th gears. (P1700)

5R110W (RWD) Transmission

Transmission Inputs

Transmission Range Sensor

The Non-contacting Pulse Width Modulated Transmission Range Sensor (TRS) provides a duty cycle signal for each position. This signal is transmitted at a frequency of 125 Hz. The PCM decodes the duty cycle to determine the driver-selected gear position (Park, Rev, Neutral, OD, 3, 2, 1). This input device is checked for out of range frequency, low duty cycle and high duty cycle input signals. (P0706, P0707, P0708)

Speed Sensors

The Turbine Shaft Speed (TSS) sensor, Intermediate Shaft Speed (ISS) sensor and Output Shaft Speed (OSS) sensor, if equipped, are hall effect inputs that are checked for rationality. The vehicle speed signal is provided from the ABS system to the PCM. If the engine rpm is above the torque converter stall speed and engine load is high, it can be inferred that the vehicle must be moving. If there is insufficient output from the VSS sensor, a malfunction is indicated (P0500). If there is insufficient output from the TSS sensor, a malfunction is indicated (P0715). If there is insufficient output from the ISS sensor, a malfunction is indicated (P0791). If there is insufficient output from the OSS sensor, a malfunction is indicated (P0720).

Transmission Fluid Temperature

5R110W has a feature called "Cold mode". If TFT is below 0 deg F, the transmission will limit operation to 1st, 2nd, 3rd, and 4th gears (5th and 6th gears are disabled). Cold mode remains in effect until TFT rises above 0 deg F or vehicle operation (based on shift times or heat generated by driving) indicates that TFT should not be in the cold mode range, at which point normal operation is enabled.

Direct clutch apply times cold have forced the addition of this cold mode (DC takes excessive times to apply below -10 deg F), and require revisions to TFT failure management – if TFT is failed at start up the transmission will be placed in cold mode and remain there until TFT is no longer failed and above 0 deg F or the vehicle operating conditions listed above trigger an exit from cold mode.

Once out of cold mode a TFT failure will not trigger cold mode (can only go into cold mode once/power-up); but this mode is new to 5R110W.

TFT is monitored for circuit faults (P0712, P0713) and in-range failures (P0711)

For this reason all TFT diagnostics illuminate the MIL on 5R110W.

Transmission Outputs

Shift Solenoids

The Shift Solenoid (SSA, SSB, SSC, SSD, and SSE) output circuits are checked for opens and shorts by the PCM by monitoring the status of a feedback circuit from the output driver (SSA P0750, P0973, P0974; SSB P0755, P0976, P0977; SSC P0760, P0979, P0980; SSD P0765, P0982, P0983; SSE P0770, P0985, P0986).

The shift solenoids will be tested for function. This is determined by vehicle inputs such as gear command, and gear. Shift solenoid malfunction codes actually cover the entire clutch system (using ratio there is no way to isolate the solenoid from the rest of the clutch system. Diagnostics will isolate the fault into clutch functionally (non-electrical) failed off (SSA P0751, SSB P0756, SSC P0761, SSD P0766, SSE P0771) and clutch functionally failed on (SSA: P0752, SSB: P0757, SSC: P0762, SSD: P0767, SSE: P0772). These fault codes replace the P2700 level clutch fault codes previously used since the additional information of the failed state of the clutch adds value for service.

Torque Converter Clutch

The Torque Converter Clutch (TCC) output circuit is a duty-cycled output that is checked electrically for opens and shorts internally in the PCM by monitoring the status of a feedback circuit from the output driver (P0740, P0742, P0744).

The TCC solenoid is checked functionally by evaluating torque converter slip under steady state conditions when the torque converter is fully applied. If the slip exceeds the malfunction thresholds when the TCC is commanded on, a TCC malfunction is indicated (P0741).

Electronic Pressure Control

The EPC solenoid is a variable force solenoid that controls line pressure in the transmission. The EPC solenoid has a feedback circuit in the PCM that monitors EPC current. If the current indicates a short to ground (low pressure), a high side switch will be opened. This switch removes power from all 7 VFSs, providing Park, Reverse, Neutral, and 5M (in all forward ranges) with maximum line pressure based on manual lever position. This solenoid is tested for open (P0960), short to ground (P0962), and short to power (P0963) malfunctions.

High Side Switch

5R110W has a high side switch that can be used to remove power from all 7 VFSs simultaneously. If the high side switch is opened, all 7 solenoids will be electrically off, providing Park, Reverse, Neutral, and 5M (in all forward ranges) with maximum line pressure based on manual lever position. The switch is tested for open faults (switch failed closed will provide normal control). If the switch fails, a P0657 fault code will be stored.

CAN Communications error

The TCM receives critical information from the ECM via CAN. If the CAN link fails, the TCM no longer has torque or engine speed information available – the high side switch will be opened. The TCM will store a U0100 fault code if unable to communicate with the TCM.

Requirements for Heavy-Duty Engine Testing

Beginning in 2005, Ford is introducing a new TorqShift (5R110W) transmission for all HDGE automatic transmission applications. This new transmission uses direct electronic shift control technology (DESC) to actuate transmission mechanisms to achieve the desired gear changes. The DESC architecture requires more extensive monitoring within the PCM of transmission components, speeds, and gear ratios to ensure that the transmission is operating within expected ranges. Without the transmission hardware present during engine dyno testing, the transmission diagnostics will presume a transmission/sensor failure, and default to self-protective operating mode. As in past years, this requires special test procedures to be used during HDGE testing to assure a representative test by simulating key signals typically generated from the transmission system. The methodology used to generate these signals has been modified for the 2005MY.

For dynamometer testing on engines using this new transmission, the function of the previously used simulator box is now incorporated as part of the transmission OBD code included in the power-train control module (PCM). The new simulator strategy expands on the old strategy and uses engine rpm, commanded gear, and manual lever position to model transmission control system responses, e.g. representative, scheduled shift points and torque modulation during shifts. The PCM will enter this 'dyno cert' mode if, at start up, the transmission OBD senses that the seven transmission variable force solenoids, the turbine speed sensor, the intermediate speed sensor, and the output speed sensor are all absent. In this mode, transmission diagnostics are disabled, a MIL code is set, and the PCM generates simulated signals that typically come from the transmission.

During the running of the transient dyno cycle, the engine follows a set path of normalized engine rpm and normalized torque as prescribed in the regulations. This simulator strategy allows the engine to perform this cycle, with the PCM reacting as if the transmission were present and the vehicle were operating on the road, resulting in representative shift events and torque modulation. These shift events follow the calibrated shift schedule, but require the input of specific transmission signals. These signals include Turbine Shaft Speed (TSS), Intermediate Shaft Speed (ISS), Output Shaft Speed (OSS), and Vehicle Speed (VSS). Since there is no transmission

hardware, these signals must be simulated. The model for the simulation strategy is based on fixed mechanical gear ratios of the transmission, scheduled shift points; small losses of efficiency in the torque converter, and approximations of transmission characteristics during transition periods (i.e. shift transition between 1st & 2nd gears). Simulated characteristics during shifts are based on extensive experience with real world transmission and vehicle operation. The initial inputs to the simulator are engine speed and transmission lever position (e.g. park, drive), these signals determine the status of the Torque Converter Clutch, and in turn output the TSS. In park, TSS equals engine rpm. In drive with the engine speed less than an approximate engine speed of 1000 rpm, the TSS equal zero. As the engine accelerates (or decelerates), the model ramps the TSS signal to respond as closely as possible to the way the turbine shaft would respond on the road. The TSS in turn, along with the status of the overdrive gear set, is used to generate the ISS. This is based on the commanded gear, and fixed gear ratios. During shift events, the model ramps the ISS signal between gear ratios. Likewise, ISS is then used, with the status of the simpson gear set, to generate the OSS, based on the fixed gear ratios. OSS is in turn used by the PCM to establish commanded gear. VSS is calculated from the OSS, using tire size and axle ratio. VSS is used within the PCM for vehicle speed limiting and as an entry condition to some of the engine on-board diagnostics.

The goal of this new 'simulator' strategy is to ensure proper function of the PCM without transmission hardware. Only the transmission OBD recognizes that the engine is in 'dyno cert' mode, the rest of the transmission control systems react as if the transmission hardware is present and is running normally as it would on the road.

6R (RWD) Transmission

Transmission Control System Architecture

The 6R is a 6-speed, step ratio transmission that is controlled by a standalone Transmission Control Module (TCM). The TCM communicates to the Engine Control Module (ECM), ABS Module, Instrument Cluster and Transfer Case Control Module using the high speed CAN communication link. The TCM incorporates a standalone OBD-II system. The TCM independently processes and stores fault codes, freeze frame, supports industry-standard PIDs as well as J1979 Mode 09 CALID and CVN. The TCM does not directly illuminate the MIL, but requests the ECM to do so. The TCM is located inside the transmission assembly. It is not serviceable with the exception of reprogramming.

Transmission Inputs

Transmission Range Sensor

The non-contacting, Hall effect Transmission Range (TR) sensor provides four digital inputs to the TCM. Each 4-bit pattern corresponds to the driver-selected gear position (Park, Rev, Neutral, D6, D4, 3, 2, 1). The 4-bit pattern is checked for invalid combinations (P0705).

Speed Sensors

The Turbine Shaft Speed (TSS) sensor and Output Shaft Speed (OSS) sensor are Hall effect sensors.

The Turbine Shaft Speed sensor is monitored for circuit faults and rationality (P0715, P0717). If turbine shaft speed exceeds a maximum calibrated speed (7,700 rpm), a fault is stored (P0716). If engine speed and output shaft speed are high and a gear is engaged, it can be inferred that the vehicle is moving. If there is insufficient output from the TSS sensor a fault is stored (P0716).

The Output Shaft Speed sensor is monitored for circuit faults and rationality (P0720, P0722). If output shaft speed exceeds a maximum calibrated speed (7,450 rpm), a fault is stored (P0721). If output shaft speed does not correlate with turbine shaft speed and wheel speed while a gear is engaged and the vehicle is moving, a fault is stored (P0721). If the output shaft speed decreases at an erratic/unreasonable rate, a fault is stored (P0723).

Transmission Fluid Temperature

The Transmission Fluid Temperature Sensor is checked for open circuit, short circuit to ground, short circuit to power, and short circuit of the sensor (P0711, P0712, P0713, P0714). The transmission fluid temperature is checked for an erratic signal (P0714) and is also compared with the internal TCM temperature sensor as a rationality check (P0711). The internal TCM temperature sensor is monitored for opens and shorts (P0667) and over temperature conditions (P0634).

Transmission Outputs

Shift Solenoids

The Shift Solenoid output circuits are duty-cycled outputs that are checked electrically for open circuit, short circuit to ground and short circuit to power by monitoring the status of a feedback circuit from the output driver (SSA - P0973, P0974; SSB - P0976, P0977; SSC - P0979, P0980; SSD - P0982, P0983; SSE - P0770, P0985, P0986). In addition, during steady states, the current flow through the Variable Force Shift Solenoids is calculated based on a current feedback signal and compared with a target current value (SSA low current - P0972; SSB high current - P0975; SSC low current - P0978; SSD high current - P0981).

The shift solenoids are functionally monitored through gear ratio and shift monitoring. The actual gear ratio versus the expected gear ratio is monitored. If there is a mismatch, a fault is stored (1st gear - P0731; 2nd gear - P0732; 3rd gear - P0733; 4th gear - P0734; 5th gear - P0735; 6th gear - P0729; reverse gear - P0736). Shifts are also

monitored. If the ratio characteristics do not change properly during a shift (rpm does not go down during an up-shift, rpm does not go up during a down-shift, or rpm flares during an up-shift), a fault is stored (1-2/2-1 shift - P0781; 2-3/3-2 shift - P0782; 3-4/4-3 shift - P0783; 4-5/5-4 shift - P0784; 5-6/6-5 shift - P0829).

Torque Converter Clutch

The Torque Converter Clutch (TCC) Solenoid output circuit is a duty-cycled output that is checked electrically for open circuit, short circuit to ground, and short circuit to power by monitoring the status of a feedback circuit from the output driver (P0740, P2763, P2764). If the TCC pressure is high and the engine torque is low, the TCC should be fully applied or have a controlled amount of slippage. If the slip exceeds a threshold, a fault is stored (P0741).

Pressure Control

The Pressure Control solenoid is a variable force solenoid that controls line pressure in the transmission. The Pressure Control solenoid output circuit is a duty-cycled output that is checked electrically for short circuit to ground or short circuit to battery by monitoring the status of a feedback circuit from the output driver (P0962, P0963).

Note that the Pressure Control Solenoid failures P0960 and P0963 do not illuminate the MIL because the diagnostic action (maximum line pressure) does not affect emissions.

High Side Actuator Control Circuit

The TCM has a high side actuator supply control circuit that can be used to remove power from all 7 solenoids and the external Reverse Light Relay simultaneously. If the high side actuator control circuit is deactivated, all 7 solenoids and the external Reverse Light Relay will be electrically turned off, providing Park, Reverse, Neutral, and 3M/5M (in all forward ranges) with maximum line pressure, based on the selected transmission range. The actuator control circuit is tested for open and short circuits to power and ground. (P0657, P0658, P0659).

Transmission Control Module (TCM)

The TCM monitors itself by using a watchdog circuit and by various software monitoring functions. If there is a fault, a P0613 is stored. The flash ROM is checked using a checksum calculation. If the checksum is incorrect, a P0605 fault will be stored. The EEPROM is emulated in the flash ROM. If it is not possible to store information in the EEPROM emulation or if the verification fails, a P062F fault is stored and the ECM is requested to illuminate the MIL immediately. If the diagnostic software tries to enter two contradictory failure mode strategies or if there are contradictory output states commanded versus the expected output states, a P0701 fault is stored.

CAN Communications Error

The TCM receives information from the ECM via the high speed CAN network. If the CAN link or network fails, the TCM no longer has torque or engine speed information available. The TCM will store a U0073 fault code and will illuminate the MIL immediately (missing engine speed) if the CAN Bus is off. The TCM will store a U0100 fault code and will illuminate the MIL immediately (missing engine speed) if it stops receiving CAN messages from the ECM. If the engine speed from the ECM is unreasonably high (> 6,000 rpm), a P0219 fault will be stored.

Internal Over Temperature

If the TCM internal temperature sensor indicates an over temperature condition, the TCM will shut down and a fault will be stored (P0634). The MIL will be illuminated immediately.

Internal TCM Power Supply

If the power supply voltage is outside of the specified 9 to 16 volt range, a fault will be stored (P0562, P0563).

Sensor Supply Voltage

If the sensor supply voltage is too high or too low, a fault will be stored (P0641).

4F27E (FN) (FWD) Transmission

Transmission Inputs

The Transmission Range Sensor (TRS) provides five digital inputs, one for Park and Neutral, one for Reverse, one for Drive, one for Second and one for First. These inputs are monitored for opens and shorts (P0705).

The Turbine Shaft Speed (TSS) sensor and Output Shaft Speed (OSS) sensors are analog inputs that are checked for rationality. If the engine rpm is above the torque converter stall speed or one of the two speed sensors has sufficient signal and engine load is high enough, it can be inferred that the vehicle must be moving. If there is insufficient output from the TSS sensor, a malfunction is indicated (P0715). If there is insufficient output from the OSS sensor, a malfunction is indicated (P0720).

Transmission Outputs

Shift Solenoids

The Shift Solenoid (SSA, SSB, SSC, SSD, and SSE) output circuits are checked for opens and shorts by the PCM by monitoring the status of a feedback circuit from the output driver (P0750, P0755, P0760, P0765 and P0770 respectively).

The shift solenoids are functionally (mechanically) checked by means of a comprehensive malfunction pattern test. This monitor examines learned gear states and the TCC function to determine if a shift solenoid mechanical failure has occurred

(P0751, P0756, P0761, P0766 and P0771 respectively).

Torque Converter Clutch

No single solenoid controls the TCC in the FN. Electrical checks for all shift solenoids are performed as indicated above. The TCC is checked functionally by evaluating torque converter slip under steady state conditions when the torque converter is fully applied. If the slip exceeds the malfunction thresholds when the TCC is commanded on, a TCC malfunction is indicated (P0741). If slip is below an open converter threshold when the TCC is commanded off, a TCC malfunction is indicated through the shift solenoid functional test (P0756).

ZF 6HP26 (RWD) Transmission

Transmission Control System Architecture

The ZF 6HP26 is a 6-speed, step ratio transmission that is controlled by a standalone Transmission Control Module (TCM). The TCM communicates to the Engine Control Module (ECM), ABS Module, Instrument Cluster and Transfer Case Control Module using the high speed CAN communication link. The TCM incorporates a standalone OBD-II system. The TCM independently processes and stores fault codes, freeze frame, supports industry-standard PIDs as well as J1979 Mode 09 CALID and CVN. The TCM does not directly illuminate the MIL, but requests the ECM to do so. The TCM is located inside the transmission assembly. It is not serviceable with the exception of reprogramming.

Transmission Inputs

Transmission Range Sensor

The non-contacting, Hall effect Transmission Range (TR) sensor provides four digital inputs to the TCM. Each 4-bit pattern corresponds to the driver-selected gear position (Park, Rev, Neutral, D6, D4, 3, 2, 1). The 4-bit pattern is checked for invalid combinations (P0705).

Speed Sensors

The Turbine Shaft Speed (TSS) sensor and Output Shaft Speed (OSS) sensor are Hall effect sensors.

The Turbine Shaft Speed sensor is monitored for circuit faults and rationality (P0715, P0717). If turbine shaft speed exceeds a maximum calibrated speed (7,700 rpm), a fault is stored (P0716). If engine speed and output shaft speed are high and a gear is engaged, it can be inferred that the vehicle is moving. If there is insufficient output from the TSS sensor a fault is stored (P0716).

The Output Shaft Speed sensor is monitored for circuit faults and rationality (P0720, P0722). If output shaft speed exceeds a maximum calibrated speed (7,450 rpm), a fault is stored (P0721). If output shaft speed does not correlate with turbine shaft speed and wheel speed while a gear is engaged and the vehicle is moving, a fault is stored (P0721). If the output shaft speed decreases at an erratic/unreasonable rate, a fault is stored (P0723).

Transmission Fluid Temperature

The Transmission Fluid Temperature Sensor is checked for open circuit, short circuit to ground, short circuit to power, and short circuit of the sensor (P0711, P0712, P0713, P0714). The transmission fluid temperature is checked for an erratic signal (P0714) and is also compared with the internal TCM temperature sensor as a rationality check (P0711). The internal TCM temperature sensor is monitored for opens and shorts (P0667) and over temperature conditions (P0634).

Transmission Outputs

Shift Solenoids

The Shift Solenoid output circuits are duty-cycled outputs that are checked electrically for open circuit, short circuit to ground and short circuit to power by monitoring the status of a feedback circuit from the output driver (SSA - P0973, P0974; SSB - P0976, P0977; SSC - P0979, P0980; SSD - P0982, P0983; SSE - P0770, P0985, P0986). In addition, during steady states, the current flow through the Variable Force Shift Solenoids is calculated based on a current feedback signal and compared with a target current value (SSA low current - P0972; SSB high current - P0975; SSC low current - P0978; SSD high current - P0981).

The shift solenoids are functionally monitored through gear ratio and shift monitoring. The actual gear ratio versus the expected gear ratio is monitored. If there is a mismatch, a fault is stored (1st gear - P0731; 2nd gear - P0732; 3rd gear - P0733; 4th gear - P0734; 5th gear - P0735; 6th gear - P0729; reverse gear - P0736). Shifts are also

monitored. If the ratio characteristics do not change properly during a shift (rpm does not go down during an up-shift, rpm does not go up during a down-shift, or rpm flares during an up-shift), a fault is stored (1-2/2-1 shift - P0781; 2-3/3-2 shift - P0782; 3-4/4-3 shift - P0783; 4-5/5-4 shift - P0784; 5-6/6-5 shift - P0829).

Torque Converter Clutch

The Torque Converter Clutch (TCC) Solenoid output circuit is a duty-cycled output that is checked electrically for open circuit, short circuit to ground, and short circuit to power by monitoring the status of a feedback circuit from the output driver (P0740, P2763, P2764). If the TCC pressure is high and the engine torque is low, the TCC should be fully applied or have a controlled amount of slippage. If the slip exceeds a threshold, a fault is stored (P0741).

Pressure Control

The Pressure Control solenoid is a variable force solenoid that controls line pressure in the transmission. The Pressure Control solenoid output circuit is a duty-cycled output that is checked electrically for short circuit to ground or short circuit to battery by monitoring the status of a feedback circuit from the output driver (P0962, P0963).

Note that the Pressure Control Solenoid failures P0960 and P0963 do not illuminate the MIL because the diagnostic action (maximum line pressure) does not affect emissions.

High Side Actuator Control Circuit

The TCM has a high side actuator supply control circuit that can be used to remove power from all 7 solenoids and the external Reverse Light Relay simultaneously. If the high side actuator control circuit is deactivated, all 7 solenoids and the external Reverse Light Relay will be electrically turned off, providing Park, Reverse, Neutral, and 3M/5M (in all forward ranges) with maximum line pressure, based on the selected transmission range. The actuator control circuit is tested for open and short circuits to power and ground. (P0657, P0658, P0659).

Transmission Control Module (TCM)

The TCM monitors itself by using a watchdog circuit and by various software monitoring functions. If there is a fault, a P0613 is stored. The flash ROM is checked using a checksum calculation. If the checksum is incorrect, a P0605 fault will be stored. The EEPROM is emulated in the flash ROM. If it is not possible to store information in the EEPROM emulation or if the verification fails, a P062F fault is stored and the ECM is requested to illuminate the MIL immediately. If the diagnostic software tries to enter two contradictory failure mode strategies or if there are contradictory output states commanded versus the expected output states, a P0701 fault is stored.

CAN Communications Error

The TCM receives information from the ECM via the high speed CAN network. If the CAN link or network fails, the TCM no longer has torque or engine speed information available. The TCM will store a U0073 fault code and will illuminate the MIL immediately (missing engine speed) if the CAN Bus is off. The TCM will store a U0100 fault code and will illuminate the MIL immediately (missing engine speed) if it stops receiving CAN messages from the ECM. If the engine speed from the ECM is unreasonably high (> 6,000 rpm), a P0219 fault will be stored.

Internal Over Temperature

If the TCM internal temperature sensor indicates an over temperature condition, the TCM will shut down and a fault will be stored (P0634). The MIL will be illuminated immediately.

Internal TCM Power Supply

If the power supply voltage is outside of the specified 9 to 16 volt range, a fault will be stored (P0562, P0563).

Sensor Supply Voltage

If the sensor supply voltage is too high or too low, a fault will be stored (P0641).

Aisin F21 (FWD) Transmission

Transmission Control System Architecture

The Aisin F21 is a 6-speed, step ratio transmission that is controlled by a standalone Transmission Control Module (TCM). The TCM communicates to the Engine Control Module (ECM), ABS Module, and Instrument Cluster using the high speed CAN communication link. The TCM incorporates a standalone OBD-II system. The TCM independently processes and stores fault codes, freeze frame, supports industry-standard PIDs as well as J1979 Mode 09 CALID and CVN. The TCM does not directly illuminate the MIL, but requests the ECM to do so. The TCM is located inside the transmission assembly. It is not serviceable with the exception of reprogramming.

Transmission Inputs

Transmission Range Sensor

The Hall effect Transmission Range (TR) sensor provides 2 analog voltage inputs to the Transmission Control Module (TCM). The voltages correspond to the driver-selected gear position (Park, Rev, Neutral, D, L). One input is high in Park, and decreases thru the ranges. The other input is the inverse of the first. These inputs are checked for opens and shorts (P0707, P0708) and invalid voltage sum (the 2 inputs should sum to 5 V +/- 0.29 V, a P0706 is stored if the sum is out of range).

Speed Sensors

The Turbine Shaft Speed (TSS) sensor and Output Shaft Speed (OSS) sensors are hall effect sensors that are checked for rational readings between each other, and with the vehicle speed signal over CAN.

If the TSS sensor is open or shorted, or in 2-nd gear and above, OSS indicates a gear-adjusted speed over 600 rpm, or the CAN VSS signal indicates a vehicle speed over 12.5 mph, a P0717 fault will be stored. If engine speed, CAN wheel speed and OSS speeds correlate but TSS error exceeds 15%, a P0716 fault will be stored.

If the OSS sensor is open or shorted, or in 2-nd gear and above, OSS calculated from wheel speed indicates a speed over 300 rpm, or the CAN VSS signal indicates a vehicle speed over 12.5 mph, a P0722 fault will be stored. If engine speed, CAN wheel speed and TSS speeds correlate but OSS error exceeds 15%, a P0721 fault will be stored.

Transmission Fluid Temperature

The Transmission Fluid Temperature Sensor (TFT) is monitored for open and short circuit faults (P0712, P0713) and for stuck in-range faults (P0711) where TFT does not change from its initial cold-start value after extended driving and end up at a reasonable temperature (> 20 deg C).

Transmission Outputs

Shift Solenoids

The on/off Shift Solenoid (SSA and SSB) output circuits are checked for open/short to power (SSA: P0974, SSB: P0977) and short to ground (SSA: P0973, SSB: P0976) by monitoring the status of a feedback circuit from the output driver.

The Variable Force Solenoid (VFS) Shift Solenoid (SSC, SSD, SSE, and SSF) output circuits are checked for short to power (SSC: P0980, SSD: P0983, SSE: P0986, SSF: P0999), open/short to ground (SSC: P0979, SSD: P0982, SSE: P0985, SSF: P0998) and stuck control current (SSC: P0978, SSD: P0981, SSE: P0984, SSF: P0997) by monitoring the status of a feedback circuit from the output driver.

The shift solenoids are monitored functionally through gear ratio monitoring (P0731 for 1st gear, P0732 for 2nd gear, P0733 for 3rd gear, P0734 for 4th gear, P0735 for 5th gear, and P0729 for 6th gear), or if the drive range is failed to Neutral (P1700 fault code).

Torque Converter Clutch

The Torque Converter Clutch (TCC) output circuit is checked for short to power (P2763), open/short to ground (P2764) and stuck control current (P2762) by monitoring the status of a feedback circuit from the output driver.

The TCC solenoid is also functionally monitored for stuck on and stuck off malfunctions. If the TCC is failed on when commanded off, engine rpm will drop to zero during a drive engagement or when coming to a stop and a P2758 fault code will be stored. If the TCC is failed off when commanded on, excessive slip (>100 rpm) will occur and a P2757 fault code will be stored.

Pressure Control Solenoid

The Pressure Control Solenoid (PCA, controls line pressure) output circuit is checked for short to power (P0963) open/short to ground (P0962) and stuck control current (P0961) by monitoring the status of a feedback circuit from the output driver.

Transmission Control Module (TCM)

The TCM monitors itself by using various software monitoring functions. The flash ROM is checked using a checksum calculation. If the checksum is incorrect during initialization, a P0601 fault will be stored. The EEPROM is emulated in the flash ROM. If it is not possible to store information in the EEPROM emulation or if the verification fails, a P0603 fault is stored and the ECM is requested to illuminate the MIL immediately. If a RAM Read/Write error is detected during initialization, a P0604 fault code will be stored.

CAN Communications error

The TCM receives information from the ECM via CAN. If the CAN link fails the TCM no longer has torque or engine speed information available. The TCM will store a U0073 fault code if the CAN Bus is off. The TCM will store a U0100 fault code if it doesn't receive any more CAN messages from the ECM. Fault codes will be stored if the ECM received invalid/faulted information for the following CAN message items: Engine Torque (P2544), Engine Speed (P1920), and pedal position (P1576).

The TCM receives wheel speed from the Antilock Brake System (ABS) module, a U0121 fault code will be stored if communication with the ABS module is lost. If the wheel speed signal is invalid or failed, a U0415 fault code will be stored.

Power Supply

If the power supply is outside of the specified 9 to 18 volt range, a fault will be stored (P0562, P0563).

Mazda FNR5 (FWD) Transmission

FNR5 is mechanically similar to the FN transmission; with an add-on gear set increasing it from a four-speed to a five-speed transmission.

Transmission Inputs

The Transmission Range Sensor (TRS) provides a single analog input to the TCM. This input voltage is monitored for mis-adjustment (P0706), opens (P0708) and shorts (P0707).

The Turbine Shaft Speed (TSS) sensor is a variable reluctance sensor; with rationality check for opens and shorts (P0715).

Intermediate Shaft Speed (ISS) and Output Shaft Speed (OSS) sensors are analog inputs that are checked for rationality. If the engine rpm is above the torque converter stall speed or one of the two speed sensors has sufficient signal, it can be inferred that the vehicle must be moving. If there is insufficient output from the ISS sensor, a malfunction is indicated (P0791). If there is insufficient output from the OSS sensor, or a disconnected sensor a malfunction is indicated (P0720).

Transmission Fluid Temperature Sensor is checked for stuck (P0711), Low input or Short (P0712) and High input or open (P0713).

Transmission Outputs

Shift Solenoids

The three On/Off Shift Solenoids (SSD, SSE, SSF) output circuits are checked for opens and shorts by the TCM by monitoring the status of a feedback circuit from the output driver (P0768, P0773, P2709 respectively). The shift solenoids are functionally (mechanically) checked by means of a comprehensive malfunction pattern test. This monitor examines gear ratios to determine if a shift solenoid failure is stuck on (P0767, P0772, P2708) or stuck off (P0766, P0771, P2707 respectively).

The four Duty Cycle Solenoids (SSA, SSB, SSC, PCB) are functionally checked by means of comprehensive malfunction patterns for stuck on (P0752, P0757, P0762, and P0777), for stuck off (P0751, P0756, P0761, no code for PCB), and have a continuity check for open or shorted (P0753, P0758, P0763, P0778).

Torque Converter Clutch

Multiple solenoids control the TCC in the FNR5 transmission. Electrical checks for all shift solenoids are performed as indicated above. The TCC is checked functionally by evaluating torque converter slip under steady state conditions when the torque converter is fully applied. If the slip exceeds the malfunction thresholds when the TCC is commanded on, a TCC malfunction is indicated (P0741). If slip is below an open converter threshold when the TCC is commanded off, a TCC malfunction is indicated through the shift solenoid functional test (P0742). The TCC also has a check for intermittent slip detection (P0744).

Pressure Control Solenoid

The Pressure Control Solenoid A is a linear solenoid. This solenoid has a continuity check for shorts and opens (P0745).

Transmission Control Module (TCM)

Power Supply

If the TCM input power voltage is low a code is set (P0882).

CAN Communications

The TCM receives information from the ECM via the high speed CAN connection. If the CAN link or network fails the TCM no longer has engine information available. The TCM will store a U0073 fault code if the CAN Bus is off or a U0100 fault code if the TCM stops receiving CAN messages from the ECM.

6F (FWD) Transmission

Transmission Inputs

Transmission Range Sensor

The 6F Digital Transmission Range (DTR) sensor provides four digital inputs to the PCM. Unlike the Ford standard digital TRS that has 1 analog and 3 digital inputs, this sensor uses 4 digital inputs, and all switches open (sensor disconnect) is an invalid bit pattern. The PCM decodes these inputs to determine the driver-selected gear position (Park, Rev, Neutral, OD, Low). This input device is checked for all switches open (P0708), invalid input patterns (P0705), and a stuck in transition zone between valid positions (P0706).

Select Shift Transmission (SST) Up/Down

6F is picking up SST for 09 MY. This system has two new PCM inputs, an upshift switch and a downshift switch. The switches are built into the shifter (defined as an H-gate in this implementation):

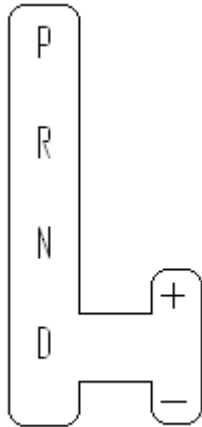

Both PCM inputs are open when the shifter is on the left hand side. From Drive as the customer moves the shifter to the right both inputs transition from open to closed (the TRS continues to indicate Drive). The control system enters "Grade Assist Mode" (provides more engine braking but still follows an automatic shift schedule) at this point. If the customer never requests a shift the control system will remain in Grade Assist Mode.

The customer requests a shift by pushing the shifter up or down, which opens the appropriate switch. Once the customer requests a shift the control system transitions from Grade Assist Mode to SST. In SST the control system follows the customer's commands except for special conditions (downshifts to the lowest available gear at high pedal, downshifts at low speeds).

Diagnostics monitors for either switch closed in Park, Reverse or Neutral, and a failure will result in non-MIL P0815 (upshift switch error) or P0816 (downshift switch error) fault codes.

If either switch fails open the customer will not be able to enter Grade Mode or SST since both switches must transition from open to closed while in the Drive position to enter SST.

If either switch is detected failed Grade Assist Mode and SST are disabled and the control system defaults to Drive (normal automatic shift schedules).

Speed Sensors

The Turbine Shaft Speed (TSS) sensor and Output Shaft Speed (OSS) sensor are Hall Effect inputs that are checked for rationality. The vehicle speed signal is provided from the ABS system (if present) to the PCM, or is derived from OSS. If the engine rpm is above the torque converter stall speed and engine load is high, it can be inferred that the vehicle must be moving. If there is insufficient output from the VSS sensor (if present), a malfunction is indicated (P0500). If there is insufficient output from the TSS sensor, a malfunction is indicated (P0715). If there is insufficient output from the OSS sensor, a malfunction is indicated (P0720).

Transmission Fluid Temperature

6F has a feature called "Cold mode" (1st implemented in 5R110W in 2003 MY). If TFT is below -20 deg F, the transmission will limit operation to 1st, 2nd, 3rd, and 4th gears (5th and 6th gears are disabled). Cold mode remains in effect until TFT rises above -20 deg F or vehicle operation (based on shift times or heat generated by driving) indicates that TFT should not be in the cold mode range, at which point normal operation is enabled.

if TFT is failed at start up the transmission will be placed in cold mode and remain there until TFT is no longer failed and above -20 deg F or the vehicle operating conditions listed above trigger an exit from cold mode.

Once out of cold mode a TFT failure will not trigger cold mode (can only go into cold mode once/power-up); this mode is the same as implemented on 5R110W in 2003.5 MY.

TFT is monitored for circuit faults (P0712, P0713) and in-range failures (P0711)

For this reason all TFT diagnostics illuminate the MIL on 6F.

Transmission Outputs

Shift Solenoids

6F has 5 shift solenoids:

1. SSA – a Variable Force Solenoid (VFS) that controls CB1234 (a brake clutch, grounds an element to the case, that is on in 1st, 2nd, 3rd and 4th gear)
2. SSB – a VFS that controls C35R (a rotating clutch on in 3rd, 5th and Reverse)
3. SSC – a VFS that controls CB26 (a brake clutch on in 2nd and 6th gear)
4. SSD – a VFS that controls either CBLR (a brake clutch on in 1st gear with engine braking and Reverse) or C456 (a rotating clutch on in 4th, 5th and 6th gear)
5. SSE – an On/Off solenoid that controls the multiplexing of SSD between CBLR and C456.

Output circuits are checked for opens, short to ground and short to power faults (codes listed in that order) by the PCM by monitoring the status of a feedback circuit from the output driver (SSA P0750, P0973, P0974; SSB P0755, P0976, P0977; SSC P0760, P0979, P0980; SSD P0765, P0982, P0983; SSE P0770).

The shift solenoids are also functional tested for stuck on and stuck off failures. This is determined by vehicle inputs such as gear command, and achieved gear (based on turbine and output speed). In general the shift solenoid malfunction codes actually cover the entire clutch system (solenoid, valves, and the clutch itself since using ratio there is no way to isolate the solenoid from the rest of the clutch system), BUT due to the hydraulic controls arrangement on 6F it is possible to isolate two specific solenoid failures from clutch system faults:

- a) SSB stuck on from C35R stuck on - due to hydraulic interlock between CBLR and C35R we can isolate SSB stuck on from C35R by turning SSE on in 1st gear without engine braking (get 1st if SSB stuck on, get 3rd if C35R is stuck on)
- b) SSD stuck off. Since SSD is multiplexed (controls both CBLR and C456) we can isolate CBLR stuck off and C456 stuck off from SSD stuck off since the latter impacts both clutch systems.

For SSA thru SSD Diagnostics will isolate the fault into clutch functionally (non-electrical) failed off (SSA P0751, SSB P0756, SSC P0761, SSD P0766) and clutch functionally failed on (SSA: P0752, SSB: P0757, SSC: P0762, SSD: P0767). The On/Off solenoid (SSE) controls the multiplexing of SSD between CBLR and C456 clutches. Using ratio we can determine if the multiplex valve is in the wrong position, but cannot be sure if the failure is due to the solenoid or a stuck valve. The multiplex valve is tested for stuck in default position (P0771, includes SSE stuck off) and stuck in spring compressed position (P0772, includes SSE stuck on) failures.

Torque Converter Clutch

The Torque Converter Clutch (TCC) solenoid is a Variable Force Solenoid. TCC solenoid circuit is checked electrically for open, short to ground and short to power circuit faults internally in the PCM by monitoring the status of a feedback circuit from the output driver (P0740, P0742, P0744).

The TCC solenoid is checked functionally by evaluating torque converter slip under steady state conditions when the torque converter is fully applied. If the slip exceeds the malfunction thresholds when the TCC is commanded on, a TCC malfunction is indicated (P0741).

For 6F the TCC is controlled by a 2 valve system - TCC reg apply and TCC control valve. Normally the TCC VFS controls the positions of these valves - turning on the TCC VFS moves both valves from the release to the apply position. If the TCC control valve sticks in the apply position then there will be no flow thru the TCC (both apply and release sides exhausted) when commanded open, which will cause the converter to overheat.

A method to detect this failure was designed into the hardware - SSE pressure is routed to the TCC reg apply valve (SSE has no effect on TCC control valve). In 3rd gear or higher if TCC is open SSE can be turned on, moving the TCC reg apply valve to the apply position. If the TCC control valve is in the wrong (apply) position this will cause the TCC to apply. If the TCC applies when SSE is turned on in 3rd, 4th, 5th or 6th gear while TCC is commanded open (TCC VFS pressure low) the failure will be detected, a P2783 DTC fault code stored. Even though this test only detects failures of the control valve, the FMEM actions alter the shift and TCC lock schedules to keep the TCC applied as much as possible, so this failure has been made MIL.

Electronic Pressure Control

The EPC solenoid is a variable force solenoid that controls line pressure in the transmission. The EPC solenoid has a feedback circuit in the PCM that monitors EPC current. If the current indicates a short to ground (low pressure), a high side switch will be opened. This switch removes power from all 6 VFSs and the on/off shift solenoid, providing Park, Reverse, Neutral, and 5M (in all forward ranges) with maximum line pressure based on manual lever position. This solenoid is tested for open (P0960), short to ground (P0962), and short to power (P0963) malfunctions.

High Side Switch

6F has a high side switch that can be used to remove power from all 7 solenoids simultaneously. If the high side switch is opened, all 7 solenoids will be electrically off, providing Park, Reverse, Neutral, and 5M (in all forward ranges) with maximum line pressure based on manual lever position. The switch is tested for open faults (switch failed closed will provide normal control). If the switch fails, a P0657 fault code will be stored.

ADLER (chip that controls all 7 solenoids) diagnostics:

The solenoids are controlled by an ADLER chip. The main micro sends commanded solenoid states to the ADLER, and receives back solenoid circuit fault information.

If communication with the ADLER is lost a P1636 fault code will be stored. If this failure is detected the states of the solenoids are unknown, so the control system will open the high side switch (removes power from all the solenoids), providing P, R, N and 5M with open TCC and max line pressure.

TRID Block

The TRID block is a portion of flash memory that contains solenoid characterization data tailored to the specific transmission to improve pressure accuracy.

The TRID block is monitored for two failures:

- a) TRID block checksum error / incorrect version of the TRID (P163E)
- b) TRID block not programmed (P163F)

If the TRID block is unavailable FMEM action limits operation to 1st and 3rd gear until the issue is correct.

On Board Diagnostic Executive

The On-Board Diagnostic (OBD) Executive is a portion of the PCM strategy that manages the diagnostic trouble codes and operating modes for all diagnostic tests. It is the "traffic cop" of the diagnostic system. The Diagnostic Executive performs the following functions:

- Sequence the OBD monitors such that when a test runs, each input that it relies upon has already been tested. For 2008 MY and beyond ISO 14229 programs, the OBD monitors are no longer sequenced by the diagnostic executive.
- Controls and co-ordinates the execution of the individual OBD system monitors: Catalyst, Misfire, EGR, O2, Fuel, AIR, EVAP and, Comprehensive Component Monitor (CCM). For 2008 MY and beyond ISO 14229 programs, the execution of the OBD monitors is no longer controlled and coordinated by the diagnostic executive.
- Stores freeze frame and "similar condition" data.
- Manages storage and erasure of Diagnostic Trouble Codes as well as MIL illumination.
- Controls and co-ordinates the execution of the On-Demand tests: Key On Engine Off (KOEO)Key On Engine Running (KOER), and the Output Test Mode (OTM). For 2008 MY and beyond ISO 14229 programs, the Output Test Mode is no longer supported by the diagnostic executive.
- Performs transitions between various states of the diagnostic and powertrain control system to minimize the effects on vehicle operation.
- Interfaces with the diagnostic test tools to provide diagnostic information (I/M readiness, various J1979 test modes) and responses to special diagnostic requests (J1979 Mode 08 and 09).
- Tracks and manages indication of the driving cycle which includes the time between two key on events that include an engine start and key off.

The diagnostic executive also controls several overall, global OBD entry conditions.

- The Diagnostic Executive waits for 4 seconds after the PCM is powered before initiating any OBD monitoring. For the 2001 MY and beyond, this delay has been eliminated to meet the "zero startup delay" misfire monitoring requirements.
- The battery voltage must fall between 11.0 and 18.0 volts to initiate monitoring cycles.
- The engine must be started to initiate the engine started, engine running, and engine off monitoring cycles.
- The Diagnostic Executive suspends OBD monitoring when battery voltage falls below 11.0 volts.
- The Diagnostic Executive suspends monitoring of fuel-system related monitors (catalyst, misfire, evap, O2, AIR and fuel system) when fuel level falls below 15%. For 2005 MY and beyond, the execution of the fuel related OBD monitors is no longer suspended for fuel level by the diagnostic executive.

The diagnostic executive controls the setting and clearing of pending and confirmed DTCs.

- A pending DTC and freeze frame data is stored after a fault is confirmed on the first monitoring cycle. If the fault recurs on the next driving cycle, a confirmed DTC is stored, freeze frame data is updated, and the MIL is illuminated. If confirmed fault free on the next driving cycle, the pending DTC and freeze frame data is erased on the next power-up.
- For the 2005 MY and later, pending DTCs will be displayed as long as the fault is present. Note that OBD-II regulations required a complete fault-free monitoring cycle to occur before erasing a pending DTC. In practice, this means that a pending DTC is erased on the next power-up after a fault-free monitoring cycle.
- For clearing comprehensive component monitoring (CCM) pending DTCs, the specific monitor must determine that no fault is present, and a 2-hour engine off soak has occurred prior to starting the vehicle. The 2-hour soak criteria for clearing CCM confirmed and pending DTCs has been utilized since the 2000

MY. For 2008 MY and beyond ISO 14229 programs, the engine off soak is no longer used by the diagnostic executive.

- After a confirmed DTC is stored and the MIL has been illuminated, three consecutive confirmed fault-free monitoring cycles must occur before the MIL can be extinguished on the next (fourth) power-up. After 40 engine warm-ups, the DTC and freeze frame data is erased.

The diagnostic executive controls the setting and clearing of permanent DTCs.

- A permanent DTC is stored when a confirmed DTC is stored, the MIL has been illuminated, and there are not yet six permanent DTCs stored.
- After a permanent DTC is stored, three consecutive confirmed fault-free monitoring cycles must occur before the permanent DTC can be erased.
- After a permanent DTC is stored, one confirmed fault-free monitoring cycle must occur, following a DTC reset request, before the permanent DTC can be erased. For 2010MY and beyond ISO 14229 programs a driving cycle including the following criteria must also occur, following the DTC reset request, before a permanent DTC can be erased:
 - Cumulative time since engine start is greater than or equal to 600 seconds;
 - Cumulative vehicle operation at or above 25 miles per hour occurs for greater than or equal to 300 seconds (medium-duty vehicles with diesel engines certified on an engine dynamometer may use cumulative operation at or above 15% calculated load in lieu of at or above 25 miles per hour for purposes of this criteria); and
 - Continuous vehicle operation at idle (i.e., accelerator pedal released by driver and vehicle speed less than or equal to one mile per hour) for greater than or equal to 30 seconds.
- A permanent DTC can not be erased by a KAM clear (battery disconnect). Additionally, its confirmed DTC counterpart will be restored after completion of the KAM reset (battery reconnect).

Exponentially Weighted Moving Average

Exponentially Weighted Moving Averaging is a well-documented statistical data processing technique that is used to reduce the variability on an incoming stream of data. Use of EWMA does not affect the mean of the data; however, it does affect the distribution of the data. Use of EWMA serves to “filter out” data points that exhibit excessive and unusual variability and could otherwise erroneously light the MIL.

The simplified mathematical equation for EWMA implemented in software is as follows:

$$\text{New Average} = [\text{New data point} * \text{“filter constant”}] + [(1 - \text{“filter constant”}) * \text{Old Average}]$$

This equation produces an exponential response to a step-change in the input data. The “Filter Constant” determines the time constant of the response. A large filter constant (i.e. 0.90) means that 90% of the new data point is averaged in with 10% of the old average. This produces a very fast response to a step change. Conversely, a small filter constant (i.e. 0.10) means that only 10% of the new data point is averaged in with 90% of the old average. This produces a slower response to a step change.

When EWMA is applied to a monitor, the new data point is the result from the latest monitor evaluation. A new average is calculated each time the monitor is evaluated and stored in Keep Alive Memory (KAM). This normally occurs each driving cycle. The MIL is illuminated and a DTC is stored based on the New Average store in KAM.

In order to facilitate repair verification and DDV demonstration, 2 different filter constants are used. A “fast filter constant” is used after KAM is cleared/DTCs are erased and a “normal filter constant” is used for normal customer driving. The “fast filter” is used for 2 driving cycles after KAM is cleared/DTCs are erased, and then the “normal filter” is used. The “fast filter” allows for easy repair verification and monitor demonstration in 2 driving cycles, while the normal filter is used to allow up to 6 driving cycles, on average, to properly identify a malfunction and illuminate the MIL.

In order to relate filter constants to driving cycles for MIL illumination, filter constants must be converted to time constants. The mathematical relationship is described below:

$$\text{Time constant} = [(1 / \text{filter constant}) - 1] * \text{evaluation period}$$

The evaluation period is a driving cycle. The time constant is the time it takes to achieve 68% of a step-change to an input. Two time constants achieve 95% of a step change input.

Catalyst Monitor and EGR Monitor EWMA

EWMA has been incorporated in the catalyst monitor and the non-intrusive stepper motor EGR monitor. There are 3 calibratable parameters that determine the MIL illumination characteristics.

“Fast” filter constant, used for 2 driving cycles after DTCs are cleared or KAM is reset

“Normal” filter constant, used for all subsequent, “normal” customer driving

Number of driving cycles to use fast filter after KAM clear (normally set to 2 driving cycles)

Several examples for a typical catalyst monitor calibration are shown in the tables below. Specific calibration information can be obtained from the parameter listing provided for each strategy.

Monitor evaluation (“new data”)	EWMA Filter Calculation, “normal” filter constant set to 0.4 Malfunction threshold = .75	Weighted Average (“new average”)	Driving cycle number	Action/Comment
0.15	$.15 * (0.4) + .15 * (1 - 0.4)$	0.15		normal 100K system
1.0	$1.0 * (0.4) + .15 * (1 - 0.4)$	0.49	1	catastrophic failure
1.0	$1.0 * (0.4) + .49 * (1 - 0.4)$	0.69	2	
1.0	$1.0 * (0.4) + .69 * (1 - 0.4)$	0.82	3	exceeds threshold
1.0	$1.0 * (0.4) + .82 * (1 - 0.4)$	0.89	4	MIL on
0.15	$.15 * (0.4) + .15 * (1 - 0.4)$	0.15		normal 100K system
0.8	$0.8 * (0.4) + .15 * (1 - 0.4)$	0.41	1	1.5 * threshold failure
0.8	$0.8 * (0.4) + .41 * (1 - 0.4)$	0.57	2	
0.8	$0.8 * (0.4) + .57 * (1 - 0.4)$	0.66	3	
0.8	$0.8 * (0.4) + .66 * (1 - 0.4)$	0.72	4	
0.8	$0.8 * (0.4) + .72 * (1 - 0.4)$	0.75	5	exceeds threshold
0.8	$0.8 * (0.4) + .75 * (1 - 0.4)$	0.77	6	MIL on

Note: For the catalyst and EGR monitor, the “fast filter” is normally set to 1.0

For the catalyst monitor, the “fast filter” is normally used to 2 driving cycles, for the EGR monitor, “fast filter” is normally used for 1 driving cycle.

I/M Readiness Code

The readiness function is implemented based on the J1979 format. A battery disconnection or clearing codes using a scan tool results in the various I/M readiness bits being set to a “not-ready” condition. As each non-continuous monitor completes a full diagnostic check, the I/M readiness bit associated with that monitor is set to a “ready” condition. This may take one or two driving cycles based on whether malfunctions are detected or not. The readiness bits for comprehensive component monitoring, misfire and fuel system monitoring are immediately considered complete since they are continuous monitors. Because the evaporative system monitor requires ambient conditions between 40 and 100 °F and BARO > 22.5 " Hg (< 8,000 ft.) to run, special logic can “bypass” the running the evap monitor for purposes of clearing the evap system I/M readiness bit due to the continued presence of these extreme conditions.

Evap bypass logic for new 1999 MY, 2000 MY, and beyond vehicles:

If the evaporative system monitor conditions are met with the exception of the 40 to 100 °F ambient temperatures or BARO range, a timer is incremented. The timer value is representative of conditions where the Evap monitor could have run (all entry conditions met except IAT and BARO) but did not run due to the presence of those extreme conditions. If the timer continuously exceeds 30 seconds during a driving cycle in which all continuous and non-continuous monitors were evaluated, the evaporative system monitor is then considered complete. If the above conditions are repeated during a second driving cycle, the I/M readiness bit for the evaporative system is set to a “ready” condition.

Power Take Off Mode

While PTO mode is engaged, the I/M readiness bits are set to a “not-ready” condition. When PTO mode is disengaged, the I/M readiness bits are restored to their previous states prior to PTO engagement. During PTO mode, only CCM circuit checks continue to be performed.

Catalyst Temperature Model

A catalyst temperature model is currently used for entry into the catalyst and oxygen sensor monitors. The catalyst temperature model uses various PCM parameters to infer exhaust/catalyst temperature. For the 1998 MY, the catalyst temperature model has been enhanced and incorporated into the Type A misfire monitoring logic. The model has been enhanced to include a misfire-induced exotherm prediction. This allows the model to predict catalyst temperature in the presence of misfire.

The catalyst damage misfire logic (Type A) for MIL illumination has been modified to require that both the catalyst damage misfire rate and the catalyst damage temperature is being exceeded prior to MIL illumination. This change is intended to prevent the detection of unserviceable, unrepeatable, burst misfire during cold engine start-up while ensuring that the MIL is properly illuminated for misfires that truly damage the catalyst.

Beginning with the 2007 MY, the catalyst temperature model is also used to generate the primary inputs to the CSER Monitor as described in that section of this document.

Serial Data Link MIL Illumination

The OBD-II diagnostic communication messages utilize an industry standard 500 kbps CAN communication link.

The instrument cluster on some vehicles uses the same CAN data link to receive and display various types of information from the PCM. For example, the engine coolant temperature information displayed on the instrument cluster comes from the same ECT sensor used by the PCM for all its internal calculations.

These same vehicles use the CAN data link to illuminate the MIL rather than a circuit, hard-wired to the PCM. The PCM periodically sends the instrument cluster a message that tells it to turn on the MIL, turn off the MIL or blink the MIL. If the instrument cluster fails to receive a message within a 5-second timeout period, the instrument cluster itself illuminates the MIL. If communication is restored, the instrument cluster turns off the MIL after 5 seconds. Due to its limited capabilities, the instrument cluster does not generate or store Diagnostic Trouble Codes.

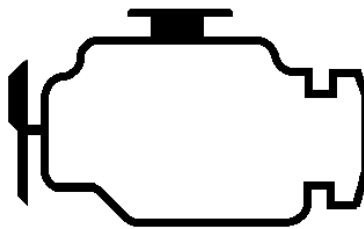

Calculated Load Value

LOAD_PCT (PID \$04) =

$$\frac{\text{current airflow}}{(\text{peak airflow at WOT@STP as a function of rpm}) * (\text{BARO}/29.92) * \text{SQRT}(298/(\text{AAT}+273))}$$

Where: STP = Standard Temperature and Pressure = 25 °C, 29.92 in Hg BARO,
 SQRT = square root,
 WOT = wide open throttle,
 AAT = Ambient Air Temperature and is in °C

