

“No PCM Communication” Job Aid – 2006 and newer

This information is not intended to replace technical training, Workshop Manual (WSM) and Powertrain Control/Emissions Diagnosis (PC/ED) Manual information.

Visual Inspection for Modifications:

When addressing a “No PCM Communication” related issue, it is important to perform a visual inspection of the vehicle in various locations. This will help identify potential tampering, modifications, or the presence/use of aftermarket electronic add-ons. Modifications that could affect communication network functionality include:

- Aftermarket remote start system.
- GPS tracking device.
- Idle control device.
- Powertrain monitoring device.
- Performance programmer.
- Insurance data logging device. (Figure 1)

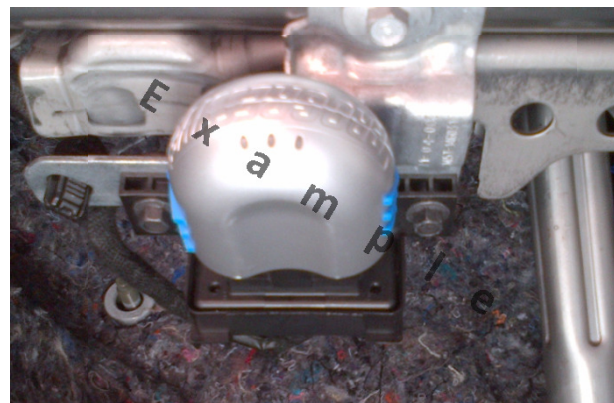

Figure 1 - Insurance data logger connected to the DLC / Gateway module

All aftermarket devices or systems connected to the communication network must be disconnected and the network retested for proper operation.

“No PCM Communication” Job Aid – 2006 and newer

PCM Tear Tag:

When there is no communication with the vehicle and the IDS (Integrated Diagnostic System) is not capable of starting an automated session, a manual entry vehicle session must be started using the PCM Tear Tag number. This will allow the IDS to start a session for the appropriate vehicle and powertrain configuration.

A manual entry vehicle session will not allow module programming.

Where can I quickly find the PCM Tear Tag number (4 digits)?

1. **OASIS VIN**
 1. Double click on the VIN at the top left corner of the blue PTS banner to display the “Detailed Vehicle Specification” screen.
 2. Tear Tag number is displayed along with other vehicle data.
2. **As-built** section of the OASIS folder tab

The screenshot shows the OASIS software interface. At the top, a blue banner displays the vehicle information: "2012 F-150" and "1FTFW1CT4CXXXXXXXX" (the VIN is circled in red). Below the banner are navigation tabs: "Home", "Vehicle ID", "OASIS", and "TSB/SSM". The "OASIS" tab is active, showing a dropdown menu with options: "OASIS Home", "As-Built" (circled in green), "SYNC", "Trans Strategy", and "Part Coverage". Below the tabs, the text "Module Rep" is visible. The VIN "1FTFW1CT4C" is displayed, and the "Tear Tag: XDZ4" is circled in green. Below this, "Vehicle Data: 4" is partially visible. A table titled "Detailed Vehicle Specification - 1FTFW1CT4C" is shown below. The table has two columns and multiple rows of data. The "TEARTAG" row at the bottom is circled in red.

Detailed Vehicle Specification - 1FTFW1CT4C	
Status	Success
Reason	
Exception	
Description	2012 F-150
MasterID	4716
Example VIN	1FTFW1EF8CF
Common Pubs ID	F-150
Oasis Description	2012 F150/LINCOLN MARK LT
Oasis Body Style	DOUBLE CAB (CREW CAB)
Oasis Engine Desc	3.5L V6 Gas DOHC TIVCT
Selling Country	USA
Build / Sell DB Source	NA / NA
Build / Sell Model Year	2012 / 2012
TEARTAG	XDZ4

PTS Tear Tag Screens

“No PCM Communication” Job Aid – 2006 and newer

The IDS Network Test:

During the Network Test, the IDS sends a request or “pings” all modules on the network and looks for a response back. Modules that do not respond back are labeled as “FAIL”. Modules that do respond back are then asked to report any DTC’s (U-codes) . A module can have no calibration loaded or be considered “blank” and still “PASS” the network test.

Modules reporting a “FAIL” on the Network Test can be due to:

- Network interference from an aftermarket device.
- Vehicle not equipped with that feature (Optional Equipment?)
- No power (B+) and/or ground to the module.
- One or both communication circuits (Bus+/-) open or shorted (together, to power, to ground).
- Internal module hardware failure.
 - This can not only affect one module’s ability to report during the test, but affect multiple modules as well.
- A module that “FAILS” can also cause other modules to report no communication DTCs, putting false blame on good modules. Address those that are a “FAIL” first.

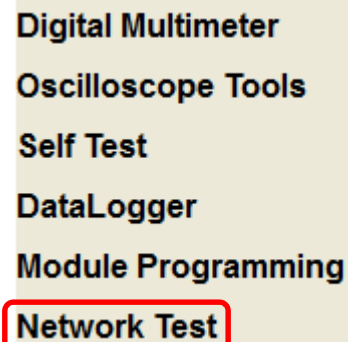

Digital Multimeter
Oscilloscope Tools
Self Test
DataLogger
Module Programming
Network Test

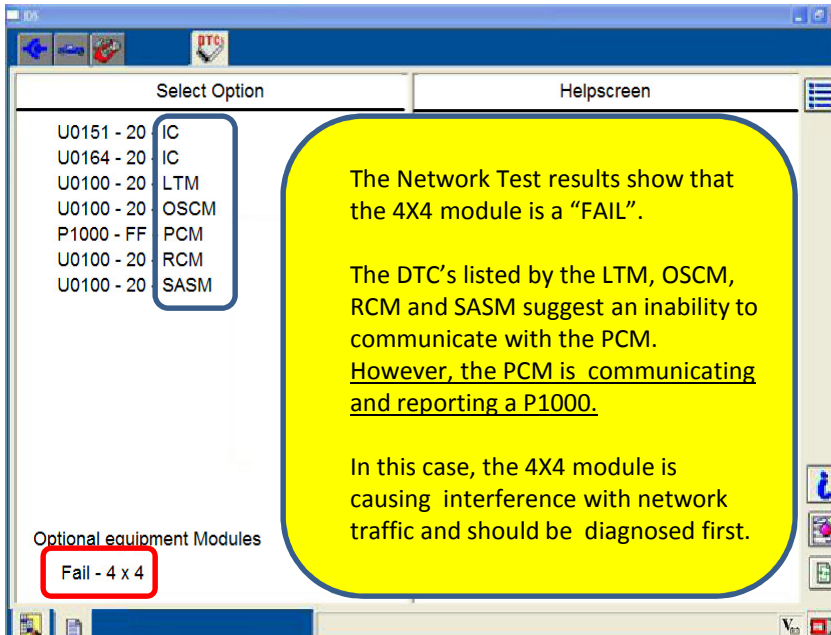

Select Option

U0151 - 20	IC
U0164 - 20	IC
U0100 - 20	LTM
U0100 - 20	OSCM
P1000 - FF	PCM
U0100 - 20	RCM
U0100 - 20	SASM

Optional equipment Modules

Fail - 4 x 4

Helpscreen

The Network Test results show that the 4X4 module is a “FAIL”.

The DTC’s listed by the LTM, OSCM, RCM and SASM suggest an inability to communicate with the PCM. However, the PCM is communicating and reporting a P1000.

In this case, the 4X4 module is causing interference with network traffic and should be diagnosed first.

“No PCM Communication” Job Aid – 2006 and newer

Network Topology:

The Network Topology map for every vehicle can be found in the WSM, Section 418-00, Module Communications Network, Description And Operation, Communications Network.

The Network Topology map can be used for:

- Identifying the modules on a given network.
- Identifying which modules have terminating resistors. (1 - 120Ω resistor in each terminating module.)
- Identifying which modules are optional (Figure 1).
- Identifying if there is a Gateway Module being used that is a terminating module. (Figure 2)

NOTE:

When addressing network concerns, the wiring diagrams in section 14-1 should always be used in conjunction with the WSM and PC/ED for the year and model being serviced.

This will help with identifying common connectors within a given leg of the network that may be suspect.

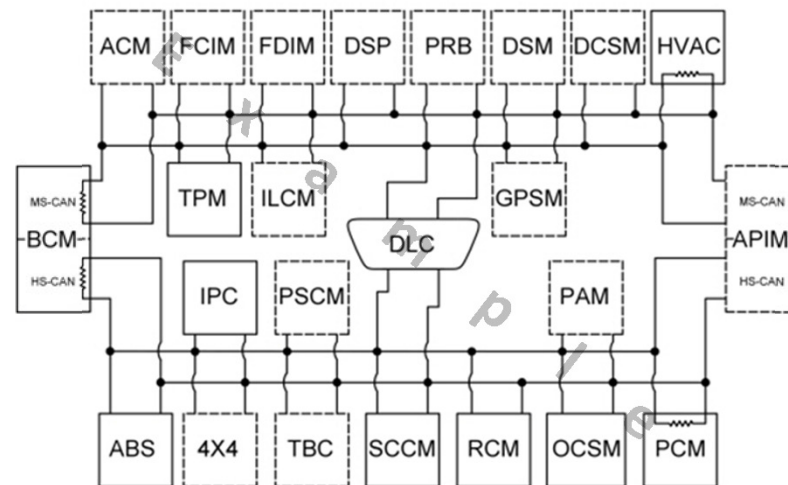

Figure 1 – Dashed lines in this Topology map style are optional modules

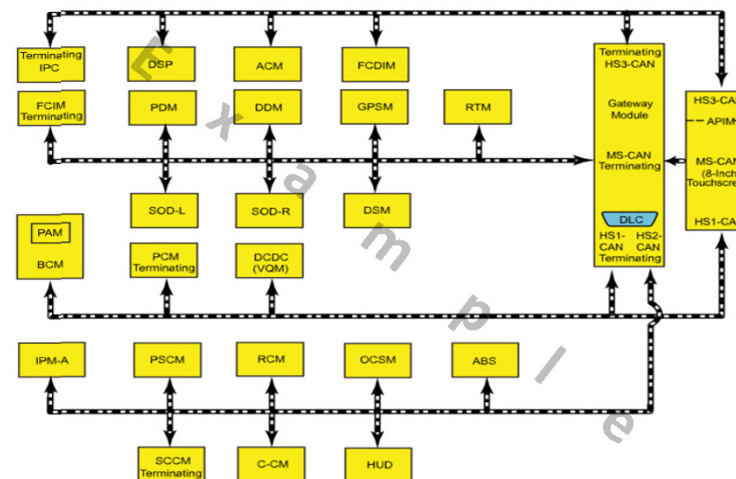

Figure 2 – This topology map shows that there is a Gateway Module in use through which all the networks are connected. This topology style does not indicate optional modules.

“No PCM Communication” Job Aid – 2006 and newer

Network Resistance Check:

NOTE: The vehicle battery must be disconnected when checking network resistance.

- Each CAN network has 2 terminating modules (each module containing a 120 Ω terminating resistor).
- When the total network resistance is measured at the DLC, the resistance should be between 54 Ω and 66 Ω . (120 Ω + 120 Ω in parallel = 60 Ω)
- When both terminating modules are removed from the network, the resistance reading should be OPEN/OL(∞).
- Any remaining resistance can suggest that a module on the network has an internal fault or the circuits are shorted together. If an internal module fault is suspected, the modules can be unplugged one at a time and the total resistance checked again to see if the faulty module has been isolated.

DLC Pin		
1	I-CAN (+)	
2	SCP (+)	
3	MS-CAN (+)	UBP
4	Ground	
5	Ground	
6	HS-CAN (+)	
7	ISO	
8	Not Used	
9	I-CAN (-)	
10	SCP (-)	
11	MS-CAN (-)	
12	Not Used	
13	FEPS (FLASH)	
14	HS-CAN (-)	
15	Not Used	
16	Battery (+)	

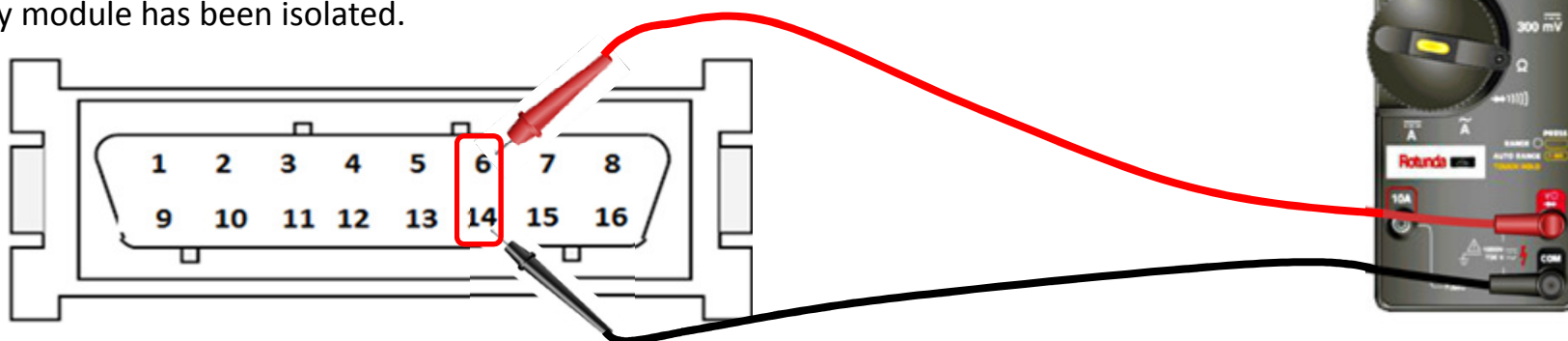

“No PCM Communication” Job Aid – 2006 and newer

Useful Tips

- Disconnecting and reconnecting the battery for ≈5 minutes (hard reset) may resolve a network concern. This should allow any module locked in a particular state to reset and return to normal operation.
- Power, ground and communication circuit integrity to the PCM are the key items needed to support a module’s ability to communicate on the network.
- If disconnecting and reconnecting a specific module resolves or changes the concern, there is likely a connection or circuit issue in that location that requires closer inspection.
- If the IDS is not capable of opening an automated vehicle session due to no communication but the engine cranks and runs normally, the concern is likely with the DLC terminals, a DLC ‘piggy back’ device/harness tap, VCM cable, VCM or IDS concern. The PCM receives messages from other modules before allowing starter enable. Starter enable supports that the PCM is communicating on the network.
- It is possible for a faulty module to create network faults that can place false blame on other modules. Equipped modules that “FAIL” the network test need to be addressed first.
- Use section 14-1 of the wiring diagrams as well as the topology map and diagnostics in section 418-00 of the online WSM. This will aid in understanding which networks are affected based on the modules that FAIL and the fault codes that were reported. Carefully follow the appropriate pinpoint steps and document all results.
 - Be sure you understand which modules the vehicle is/is not equipped with.
- The vehicle battery must be disconnected when checking total network resistance.
- When checking connections, be sure to look for terminal spreading, terminals not locked into the connector cavity and for signs of moisture that could influence intermittent faults.