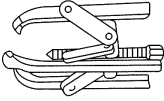
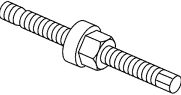
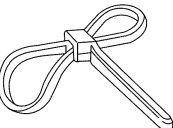

IN-VEHICLE REPAIR

Crankshaft Pulley

Special Tool(s)

 <p>ST1184-A</p>	<p>3-Jaw Puller 303-D121</p>
 <p>ST1287-A</p>	<p>Installer, Crankshaft Vibration Damper 303-102 (T74P-6316-B)</p>
 <p>ST1438-A</p>	<p>Strap Wrench 303-D055 (D85L-6000-A) or equivalent</p>

Material

Item	Specification
Motorcraft Metal Surface Prep ZC-31	—
Motorcraft SAE 5W-50 Full Synthetic Motor Oil XO-5W50-QGT or equivalent	WSS-M2C931-B
Silicone Gasket and Sealant TA-30	WSE-M4G323-A4
Silicone Gasket Remover ZC-30	—

Removal

1. With the vehicle in NEUTRAL, position it on a hoist. For additional information, refer to Section 100-02.
2. Remove the cooling fan assembly. For additional information, refer to Section 303-03A.

3. Rotate the supercharger (SC) drive belt tensioner clockwise and remove the drive belt from the SC drive pulley.

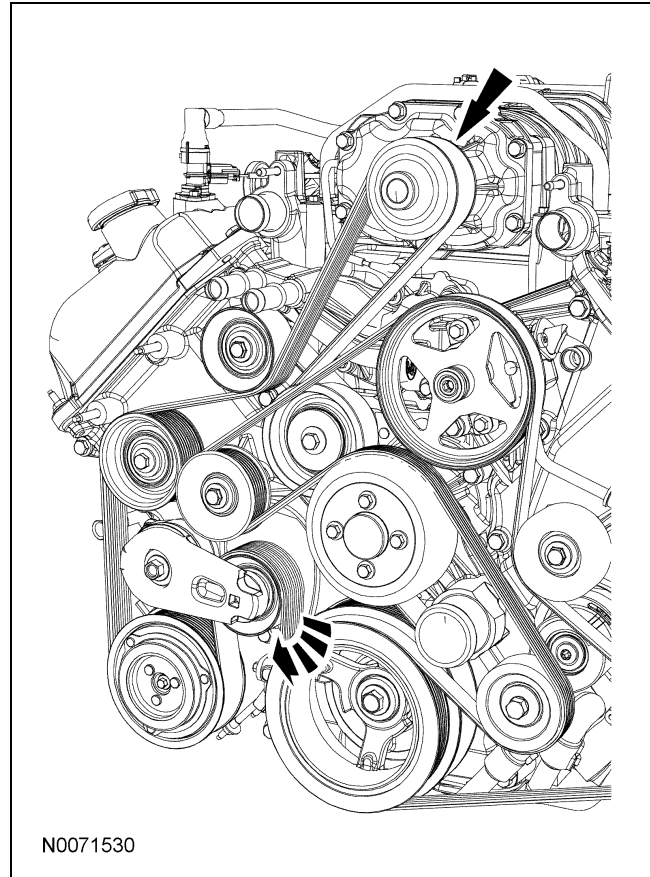

IN-VEHICLE REPAIR (Continued)

- Rotate the accessory drive belt tensioner clockwise and remove the accessory drive belt from the power steering pump pulley.

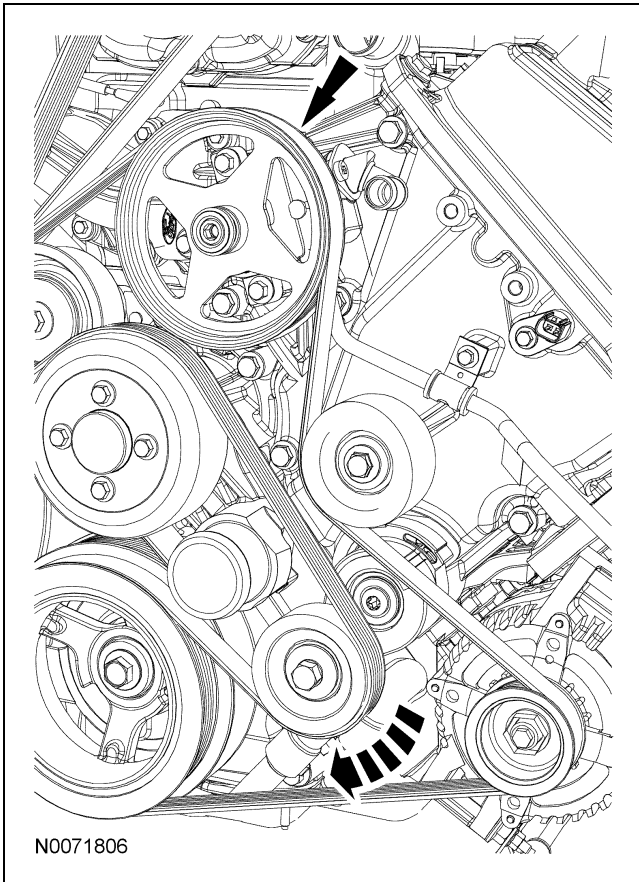

- Position the accessory drive belt and SC drive belt away from the crankshaft pulley.
- Using the special tool, remove the crankshaft pulley bolt and the washer.
 - Discard the bolt.

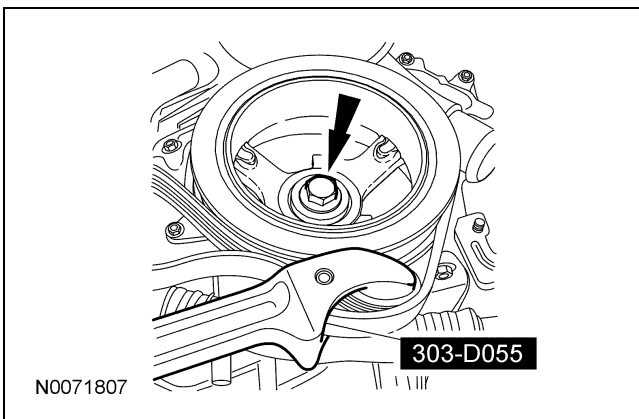

- Using the special tool, remove the crankshaft pulley.

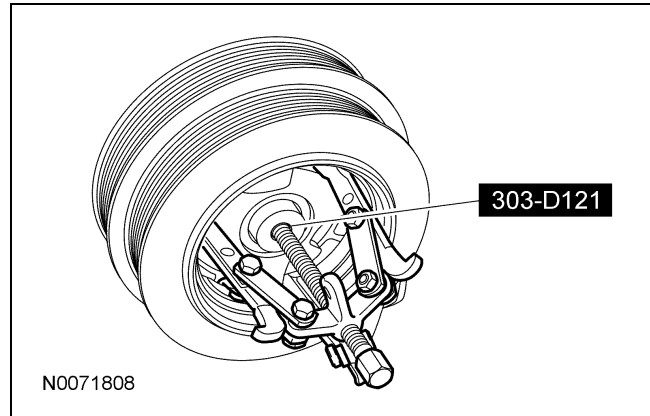
**Installation**

- NOTE:** If not secured within 4 minutes, the sealant must be removed and the sealing area cleaned. To clean the sealing area, use silicone gasket remover and metal surface prep. Follow the directions on the packaging. Failure to follow this procedure can cause future oil leakage.

Apply silicone gasket and sealant to the Woodruff key slot on the crankshaft pulley.

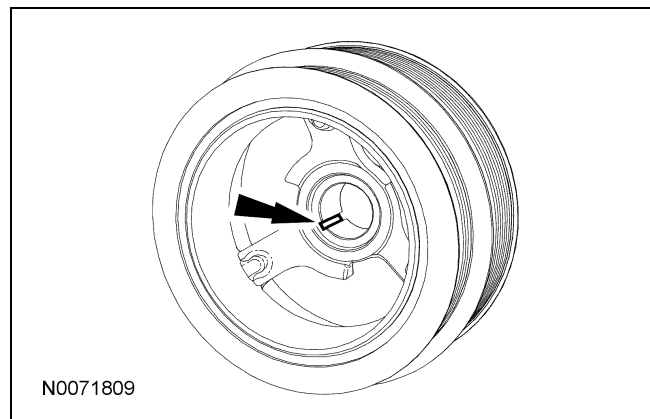

- Lubricate the crankshaft pulley sealing surface with clean engine oil prior to installation.

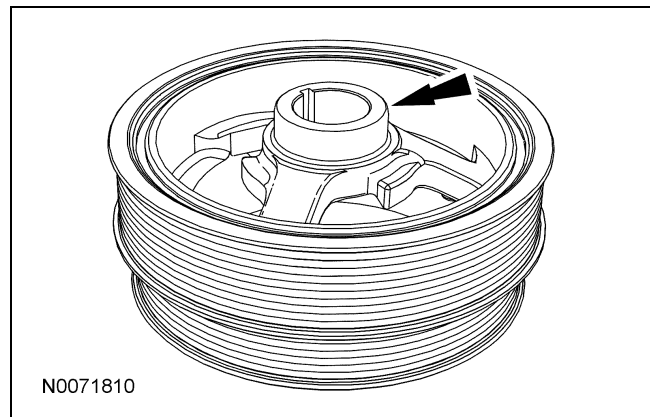

IN-VEHICLE REPAIR (Continued)

- Using the special tool, install the crankshaft pulley.

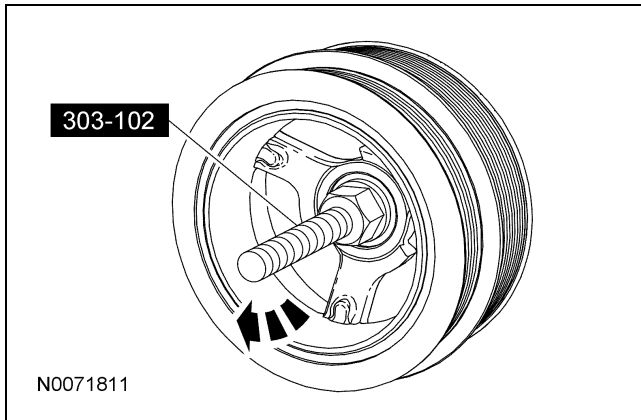

- Using the special tool, install a new crankshaft pulley bolt and the original washer, tighten the bolt in 4 stages:
 - Stage 1: Tighten to 120 Nm (88 lb-ft).
 - Stage 2: Loosen one full turn.
 - Stage 3: Tighten to 50 Nm (37 lb-ft).
 - Stage 4: Tighten an additional 90 degrees.

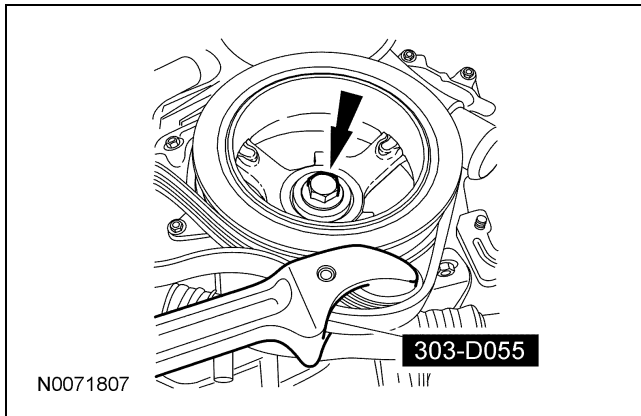

- Position the accessory drive belt and SC drive belt onto the crankshaft pulley.
- Rotate the accessory drive belt tensioner clockwise and install the accessory drive belt onto the power steering pump pulley.

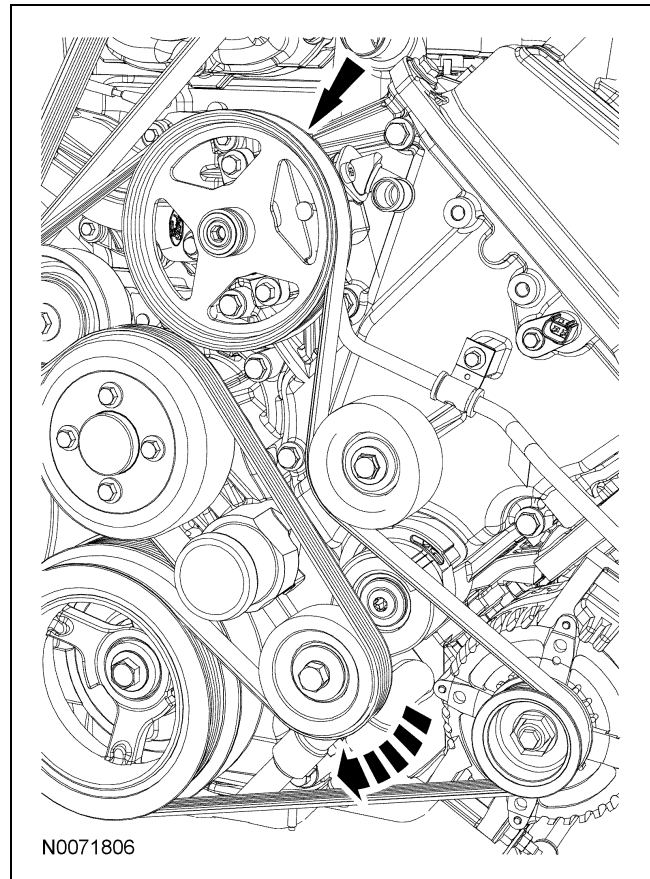

IN-VEHICLE REPAIR (Continued)

7. Rotate the SC drive belt tensioner clockwise and install the drive belt onto the SC drive pulley.
8. Install the cooling fan assembly. For additional information, refer to Section 303-03A.

