

STRAP CRADLE AND SENSOR INSTALLATION

CONTENTS

ASSEMBLY

[Tire Pressure Monitoring System \(TPMS\) Strap, Cradle and Sensor](#)

[Tire Pressure Monitoring System \(TPMS\) Sensor Training and Activation](#)

ASSEMBLY

Tire Pressure Monitoring System (TPMS) Strap, Cradle and Sensor

Material

Item	Specification
Wheel and Tire Cleaner	ZC-37-A

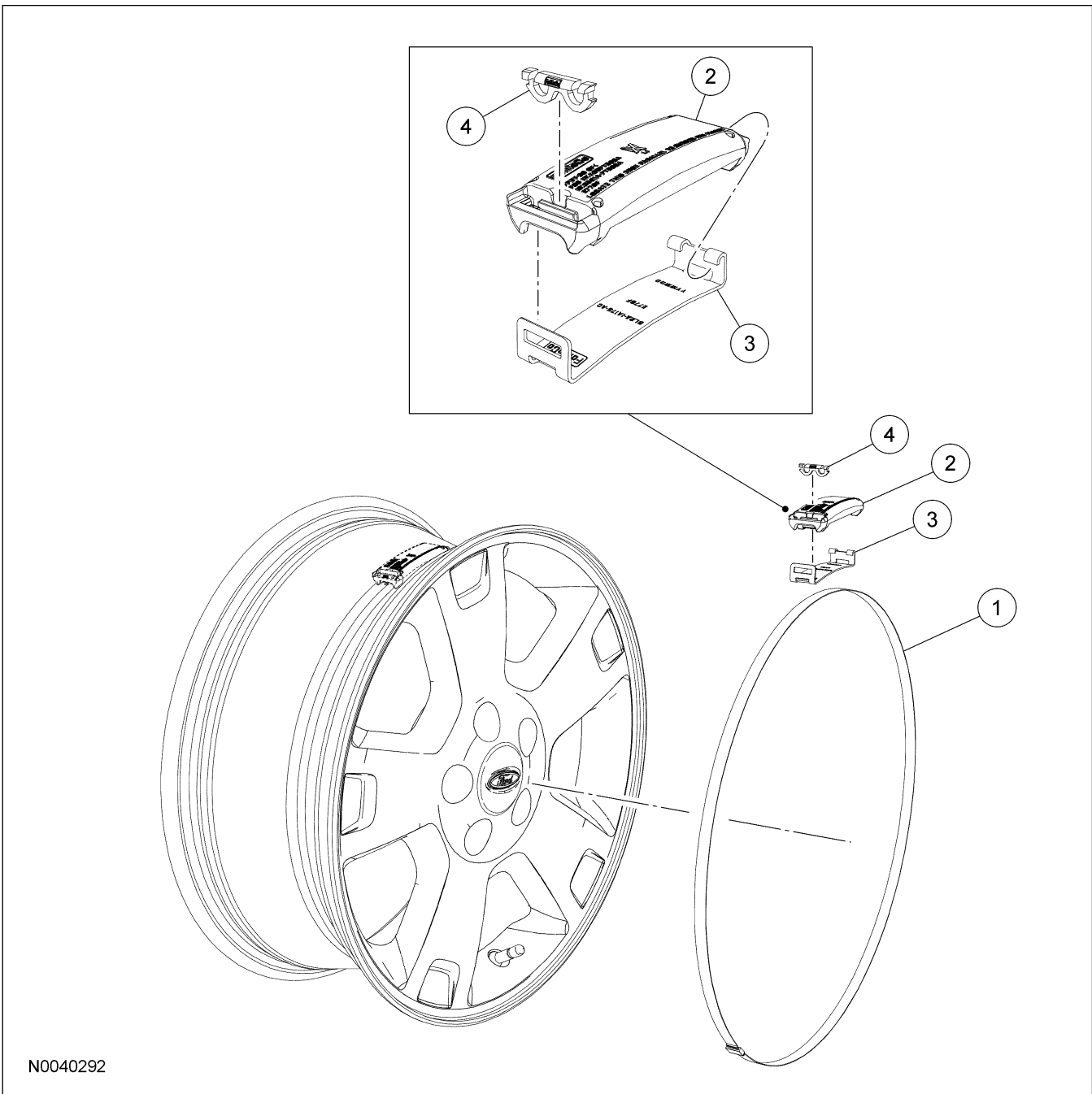

N0040292

ASSEMBLY (Continued)

Item	Part Number	Description
1	1A177*	Strap
2	1A176*	Tire pressure sensor
3	1A175*	Sensor cradle
4	14C202*	Locking clip

* Indicates Number of Parts in Kit Equals 4

Assembly

⚠ WARNING: The tire pressure monitoring system (TPMS) sensor battery may release hazardous chemicals if exposed to extreme mechanical damage. If these chemicals contact the skin or eyes, flush immediately with water for a minimum of 15 minutes and get prompt medical attention. If any part of the battery is swallowed, contact a physician immediately. When disposing of TPMS sensors, follow the correct procedures for hazardous material disposal. Failure to follow these instructions may result in serious personal injury.

NOTE: Tire pressure sensors are equipped with Lithium-ion batteries and must be disposed of accordingly.

NOTE: There are several different strap kits available based on wheel diameter, but all strap kits share the same base part number.

- 1. NOTICE:** Damage to the sensor may occur if excessive force is applied during sensor installation.

NOTE: Make sure the sensor is fully seated into the new cradle. The sensor will make a “click” noise when fully seated.

Position the sensor into the new cradle by inserting the hinge end of the sensor into the hook end of the cradle and pushing the opposite end of the sensor down onto the cradle.

- 2. NOTE:** The sensor and cradle must be installed in the drop well of the wheel, 180 degrees from the valve stem.

Using wheel and tire cleaner, clean the area where the sensor and cradle are to be installed.

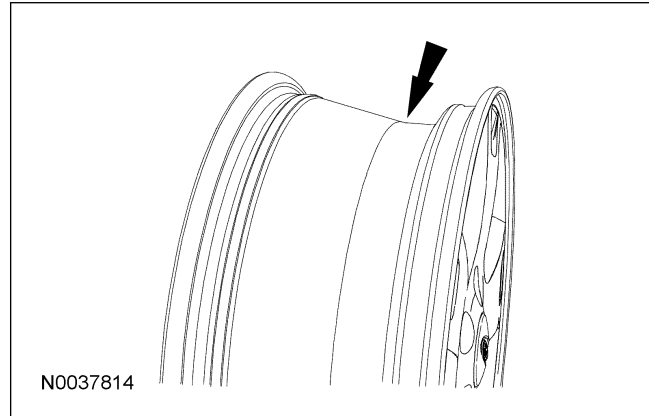

- 3. NOTE:** The sensor and cradle must be positioned with the hinge side of the sensor on the RH side when viewed from the curb side (beauty side) of the wheel.

NOTE: The sensor has raised markings indicating how to position the sensor.

Remove the adhesive tape liner from the cradle and position the sensor and cradle into the wheel drop well 180 degrees from the valve stem.

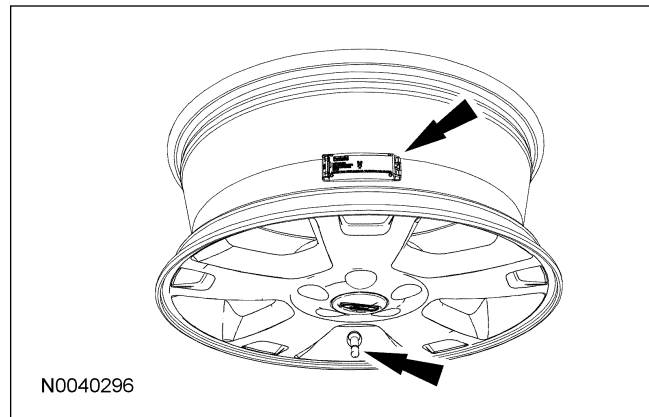

ASSEMBLY (Continued)

4. Install the tapered end of the strap through the opening of the cradle on the hinge side of the sensor. This will position the worm gear on the locking clip side of the sensor.

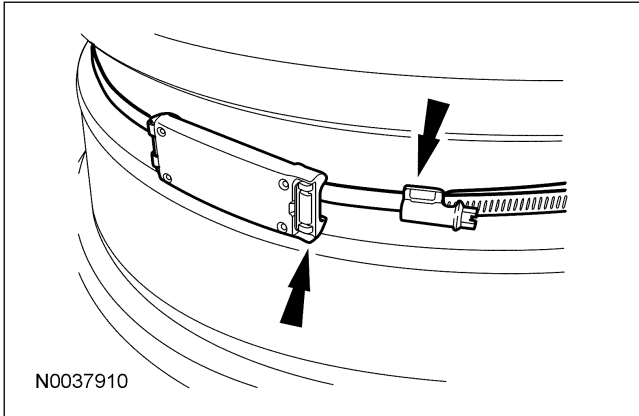

5. **NOTICE:** Use only a soap and water solution to lubricate the tire. Use of anything other than soap and water may result in damage to the Tire Pressure Monitoring System (TPMS) sensor.

Position the wheel on the turntable of the tire machine, then lubricate and position the bottom bead of the tire on the wheel.

6. Position the wheel to align the valve stem with the machine arm, at the 6 o'clock position, and mount the bottom bead of the tire.

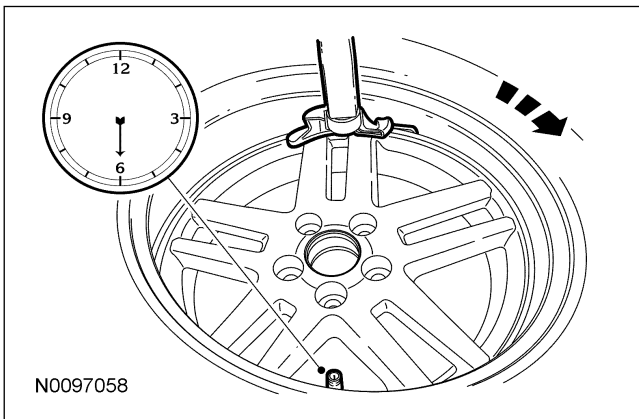

7. Reposition the wheel to align the valve stem with the machine arm, at the 6 o'clock position, and mount the top bead of the tire.

8. **NOTE:** Use only the Digital Tire Gauge any time tire pressures are measured to make sure that accurate values are obtained.

Inflate the tire to the pressure specified in the Chrome Accessory Wheel Restrictions and Tire Pressures. Refer to the installation instruction section of the Genuine Ford Accessories Web Site.

- Proceed to Step 8 if the tire beads do not seat at the specified inflation pressure.

9. **⚠ WARNING:** If there is a need to exceed the maximum pressure indicated on the sidewall of the tire, in order to seat the beads, follow ALL the steps listed below. Failure to follow these steps may result in serious personal injury.

The following steps should only be carried out if the tire beads cannot be seated by inflating the tire up to the maximum inflation pressure listed on the tire sidewall.

- 1 Relubricate the tire bead and wheel bead seat area.
- 2 Install a remote valve and pressure gauge.
- 3 Wear eye and ear protection and stand at a minimum of 3.65 m (12 ft) away from the wheel and tire assembly.
- 4 Inflate the tire using the remote valve and tire gauge until the beads have seated or until the pressure gauge is 138 kPa (20 psi) more than maximum inflation pressure on tire sidewall. If beads have not seated, deflate the tire and proceed to the next step.
- 5 Place the wheel and tire assembly in an OSHA-approved tire safety cage.
- 6 Inflate the tire using the remote valve and pressure gauge until the beads have seated or until the pressure gauge is 276 kPa (40 psi) more than maximum inflation pressure on the tire sidewall. **Do not exceed 276 kPa (40 psi) above the maximum pressure on tire sidewall. Install a new tire if the beads do not seat at this pressure.**

10. Install the wheel and tire.

GENERAL PROCEDURES

Tire Pressure Monitoring System (TPMS) Sensor Training and Activation

Special Tool(s)

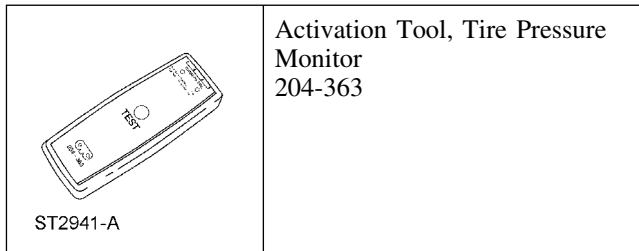

NOTE: If the vehicle has been stationary for more than 30 minutes, the sensors will go into a “sleep mode” to conserve battery power. It will be necessary to wake them up so they will transmit the latest tire pressure information to the Smart Junction Box (SJB). For additional information, refer to Tire Pressure Monitoring System (TPMS) Sensor Activation in this section.

NOTE: The tire pressure sensor training procedure must be done on a single vehicle, in an area without radio frequency noise and at least 1 m (3 ft) away from other vehicles equipped with a Tire Pressure Monitoring System (TPMS).

Radio frequency noise is generated by electrical motors and appliance operation, cellular telephones, remote transmitters, power inverters and portable entertainment equipment.

NOTE: If a sensor does not respond to the Tire Pressure Monitor Activation Tool, attempt to activate the same sensor with the Tire Pressure Monitor Activation Tool. If the sensor still does not respond, move the vehicle to rotate the wheels at least one-fourth of a turn and attempt to activate the same sensor again.

NOTE: The SJB has a 2-minute time limit between sensor responses. If the SJB does not recognize any 1 of the 4 tire pressure sensors during this time limit, the horn will sound twice and the message center (if equipped) will display TIRE NOT TRAINED REPEAT and the entire procedure must be repeated.

NOTE: For vehicles with different front and rear tire pressures (such as the E-Series and certain F-Series), the tire pressure sensors must be trained following a tire rotation. Failure to train the sensors will cause the TPMS indicator to illuminate. For vehicles with the same tire pressure for front and rear tires, tire rotation will not affect the system.

1. Turn the ignition switch to the OFF position, then press and release the brake pedal.
2. Cycle the ignition switch from the OFF position to the RUN position 3 times, ending in the RUN position.
3. Press and release the brake pedal.
4. Turn the ignition switch to the OFF position.
5. Turn the ignition switch from the OFF position to the RUN position 3 times, ending in the RUN position.
 - The horn will sound once and the TPMS indicator will flash if the training mode has been entered successfully. If equipped, the message center will display TRAIN LF TIRE.
6. **NOTE:** It may take up to 6 seconds to activate a tire pressure sensor. During this time, the Tire Pressure Monitor Activation Tool must remain in place 180 degrees from the valve stem. Place the Tire Pressure Monitor Activation Tool on the LF tire sidewall opposite (180 degrees) from the valve stem. Press and release the test button on the Tire Pressure Monitor Activation Tool. The horn will sound briefly to indicate that the tire pressure sensor has been recognized by the SJB.

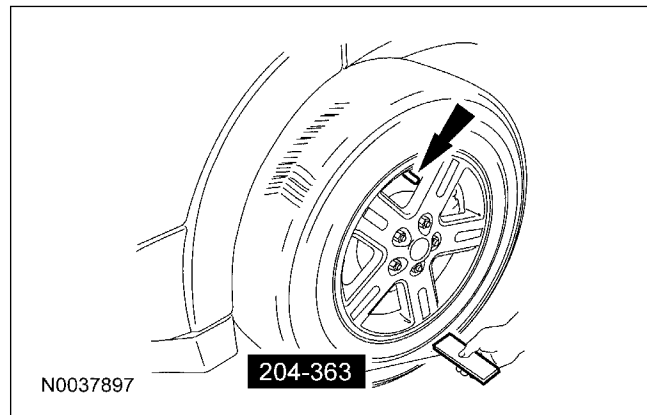

GENERAL PROCEDURES (Continued)

7. Within 2 minutes of the horn sounding, place the Tire Pressure Monitor Activation Tool on the RF tire sidewall opposite (180 degrees) from the valve stem and press and release the test button to train the RF tire pressure sensor.

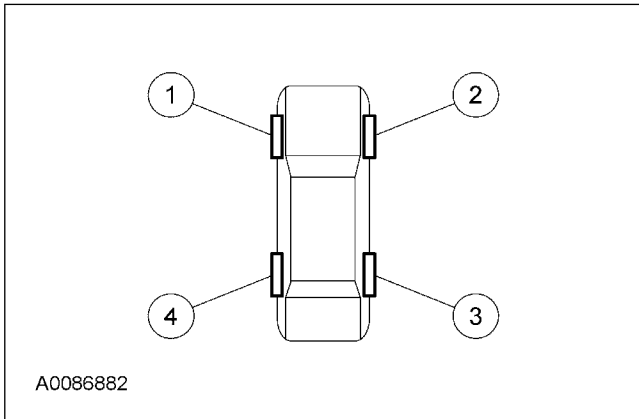

8. **NOTE:** Do not wait more than 2 minutes between training each sensor or the SJB will time out and the entire procedure must be repeated.

Repeat Step 7 for the RR and LR tires.

The procedure is completed after the last tire has been trained. When the training procedure is complete, the message center (if equipped) will display TIRE TRAINING COMPLETE.

For vehicles not equipped with a message center, successful completion of the training procedure will be verified by turning the ignition switch to the OFF position without the horn sounding. If the horn sounds twice when the switch is turned to the OFF position, the training procedure was not successful.