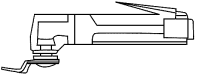

REMOVAL AND INSTALLATION

Window Glass — Roof

Special Tool(s)

 ST1109-A	Rotunda Pneumatic Knife with Offset Blade 164-R1511 or equivalent
---	--

Material

Item	Specification
Dow Urethane Adhesive Betaseal® Express	—
Dow Urethane One Step Glass Primer Betaprime® 5500 / 5500A / 5500SA	—
Sika Urethane Adhesive Sika Tack ASAP	—
Sika Urethane Metal and Glass Primer Sika 206 G+P	—
Ultra-Clear Spray Glass Cleaner ZC-23	ESR-M14P5-A

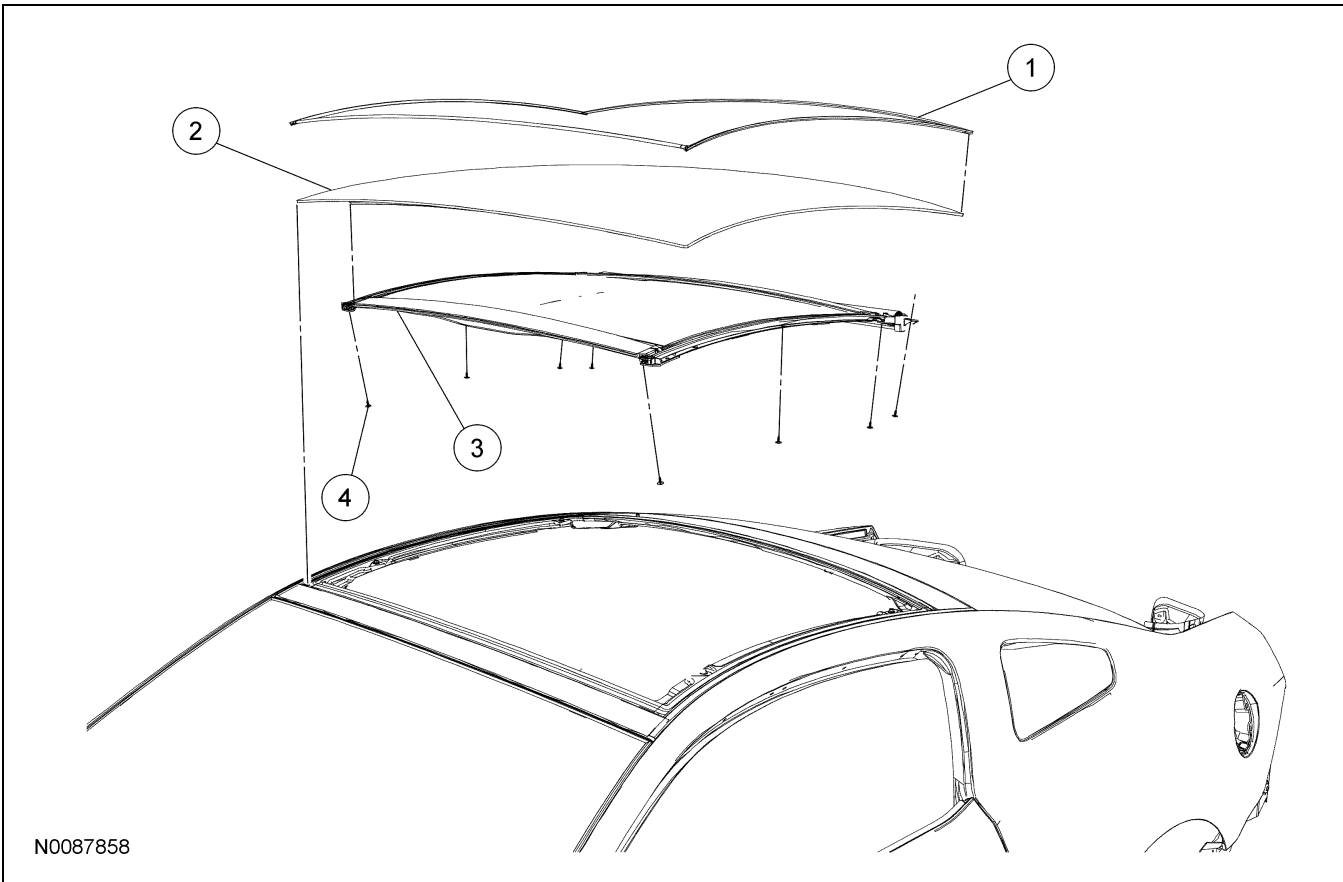

N0087858

Item	Part Number	Description
1	—	Roof glass panel seal (part of roof glass panel)
2	50054	Roof glass panel

(Continued)

Item	Part Number	Description
3	519A02	Roof glass shade assembly
4	—	Roof glass shade assembly screw (8 required) (part of roof glass shade assembly)

REMOVAL AND INSTALLATION (Continued)

Removal

- ⚠ WARNING: Always wear eye protection when servicing a vehicle. Failure to follow this instruction may result in serious personal injury.**

⚠ WARNING: Wear protective gloves when handling components or parts that have pointed or sharp edges. Failure to follow this instruction may result in serious personal injury.

NOTICE: Protect the surrounding painted surfaces as required to prevent damage when cutting the urethane adhesive.

NOTE: Lubricate the existing urethane adhesive with water to aid the Rotunda Pneumatic Knife with Offset Blade while cutting.

From outside the vehicle, begin cutting the urethane adhesive from the front corner and work around the perimeter of the roof glass panel using the Rotunda Pneumatic Knife with Offset Blade.
- NOTE:** The roof glass shade assembly is attached to the roof glass panel. The roof glass panel and roof glass shade assembly will be removed as an assembly.

Carefully remove the roof glass panel assembly and place on a stable work surface with the interior side facing up.
- If installing a new roof glass panel, remove the 8 screws and transfer the existing roof glass shade assembly to the new roof glass panel.

Installation

- Carefully dry fit the roof glass panel to the existing urethane adhesive bead on the body pinch weld. Align the roof glass panel in the opening for a uniform fit.
- Use a non-permanent pencil to make alignment marks on the roof glass panel and the body to aid in the installation alignment of the roof glass panel.

- Carefully remove the roof glass panel and place on a stable surface.
- ⚠ WARNING: Repair any corrosion found on the pinch weld. The pinch weld is a structural component of the vehicle. Corrosion left unrepaired may reduce the structural integrity of the vehicle. Failure to follow this instruction may result in serious injury to vehicle occupant(s).**

NOTE: To make sure the new urethane adhesive bonds correctly to the original equipment urethane adhesive, the roof glass panel must be installed within 2 hours of trimming the original urethane adhesive bead.

NOTE: Avoid scratching the pinch weld. Repair all minor scratches or exposed metal on the pinch weld following manufacturer's instructions. Use the same brand pinch weld primer, glass primer and urethane adhesive.

Using an appropriate tool, trim the urethane adhesive leaving a 1-2 mm (0.04-0.08 in) base of original equipment urethane adhesive on the pinch weld.

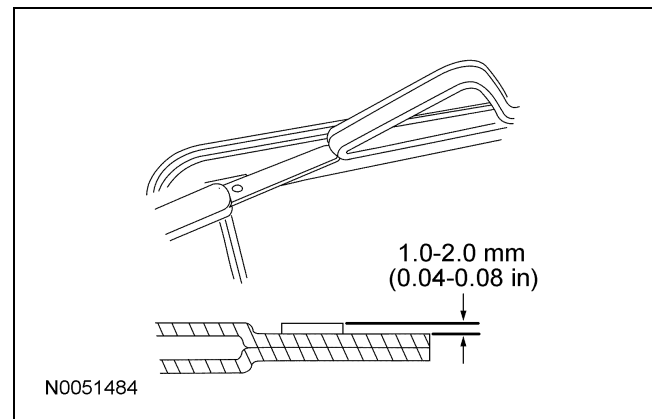

- Using a soft brush or vacuum, remove any dirt or foreign material from the pinch weld.
- If installing the original roof glass panel, remove the excess urethane adhesive on the glass.
- Clean the inside of the roof glass panel surface with glass cleaner.

REMOVAL AND INSTALLATION (Continued)

8. **NOTE:** For additional material guidelines, refer to the manufacturer's installation information.

NOTE: Be sure to use the same brand and cure-rate products for the urethane adhesive and glass primer. Do not mix different brands of urethane adhesive and glass primer. Refer to the Material Chart in this procedure.

If installing a new roof glass panel, apply glass primer according to manufacturer's instructions. Allow at least 6 minutes to dry.

9. Cut the urethane adhesive applicator tip to specification.

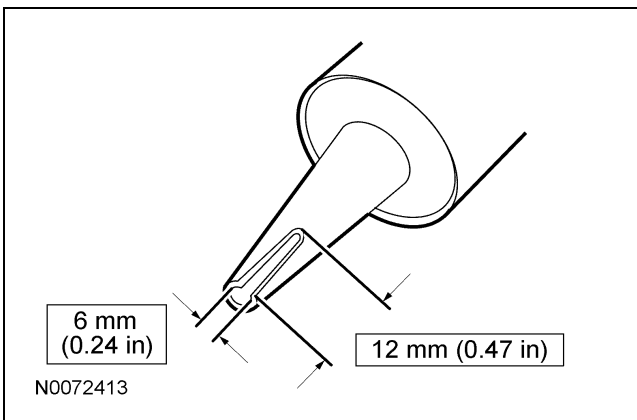

10. **NOTE:** The roof glass panel must be positioned within 10 minutes of applying the urethane adhesive.

NOTE: Use either a high-ratio, electric or battery-operated caulk gun that will apply the urethane adhesive with less effort and continuous bead.

Apply urethane adhesive on top of the existing trimmed urethane adhesive bead on the pinch weld, starting and ending at the rear of the roof opening near the center, making sure there are no gaps in the bead.

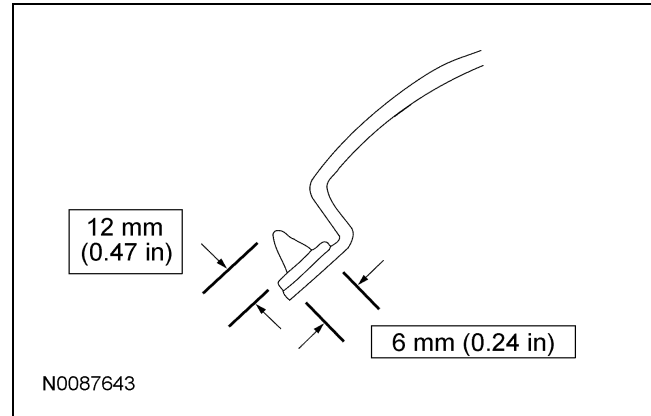

11. **⚠ WARNING: Do not drive vehicle until the urethane adhesive seal has cured. Follow urethane adhesive manufacturer's curing directions. Inadequate or incorrect curing of the urethane adhesive seal will adversely affect glass retention. Failure to follow these instructions may result in serious injury to vehicle occupant(s).**

Carefully install the roof glass panel on the vehicle aligning it with the markings made previously.

- Work the roof glass panel down using only vertical pressure.

12. After the urethane adhesive has cured, clean the interior and exterior roof glass panel with glass cleaner.