



# **1997 MY OBD System Operation**

## **Summary for Gasoline Engines**

### Table of Contents

Introduction – OBD-I and OBD-II.....	3
Catalyst Efficiency Monitor.....	4
Misfire Monitor.....	6
AIR System Monitor .....	10
EVAP System Functional Monitor – Purge Valve Functional Check.....	11
EVAP System Monitor - 0.040" dia. Leak Check .....	13
Fuel System Monitor .....	17
HO2S Monitor .....	18
DPFE EGR System Monitor .....	22
Comprehensive Component Monitor - Engine.....	27
Comprehensive Component Monitor - Transmission .....	32
4R70W (RWD) Transmission .....	39
AX4S/AX4N (FWD) Transmission .....	41
CD4E (FWD) Transmission.....	42

4R44E (RWD) Transmission .....	43
5R55E (RWD) Transmission .....	44
4R100 (E4OD) (RWD) Transmission.....	46
On Board Diagnostic Executive.....	47
Exponentially Weighted Moving Average .....	48
I/M Readiness Code.....	50
Serial Data Link MIL Illumination .....	50

## Introduction – OBD-I and OBD-II

### OBD-II Systems

California OBD-II applies to all gasoline engine vehicles up to 14,000 lbs. Gross Vehicle Weight Rating (GVWR) starting in the 1996 MY and all diesel engine vehicles up to 14,000 lbs. GVWR starting in the 1997 MY.

Federal OBD applies to all gasoline engine vehicles up to 8,500 lbs. GVWR starting in the 1996 MY and all diesel engine vehicles up to 8,500 lbs. GVWR starting in the 1997 MY.

OBD-II system implementation and operation is described in the remainder of this document.

### OBD-I Systems

If a vehicle is not required to comply with OBD-II requirements, it utilizes an OBD-I system. OBD-I systems are used on all over 8,500 lbs. GVWR Federal truck calibrations. With the exception of the 1996 MY carryover EEC-IV OBD-I systems, Federal > 8,500 lbs. OBD-I vehicles use that same PCM, J1850 serial data communication link, J1962 Data Link Connector, and PCM software as the corresponding OBD-II vehicle. The only difference is the possible removal of the rear oxygen sensor(s), fuel tank pressure sensor, canister vent solenoid, and a different PCM calibration.

The following list indicate what monitors and functions have been altered for OBD-I calibrations:

Monitor / Feature	Calibration
Catalyst Monitor	Not required, monitor calibrated out, rear O2 sensors may be deleted.
Misfire Monitor	Calibrated in for service, all DTCs are non-MIL. Catalyst damage misfire criteria calibrated out, emission threshold criteria set to 4%, enabled between 150 °F and 220 °F, 254 sec start-up delay.
Oxygen Sensor Monitor	Rear O2 sensor test calibrated out, rear O2 sensors may be deleted, front O2 sensor response test calibrated out, O2 heater current test calibrated out prior to 2002 MY, O2 heater voltage test used for all model years.
EGR Monitor	Same as OBD-II calibration except that P0402 test uses slightly higher threshold.
Fuel System Monitor	Same as OBD-II calibration starting in 2002 MY, earlier calibrations used +/- 40% thresholds.
Secondary Air Monitor	Functional (low flow) test calibrated out, circuit codes are same as OBD-II calibration.
Evap System Monitor	Evap system leak check calibrated out, fuel level input circuit checks retained as non-MIL. Fuel tank pressure sensor and canister vent solenoid may be deleted.
PCV Monitor	Same hardware and function as OBD-II.
Thermostat Monitor	Thermostat monitor calibrated out.
Comprehensive Component Monitor	All circuit checks same as OBD-II. Some rationality and functional tests calibrated out. (MAF/TP rationality, IAC functional)
Communication Protocol and DLC	Same as OBD-II, all generic and enhanced scan tool modes work the same as OBD-II but reflect the OBD-I calibration that contains fewer supported monitors. "OBD Supported" PID indicates OBD-I.
MIL Control	Same as OBD-II, it takes 2 driving cycles to illuminate the MIL.

## Catalyst Efficiency Monitor

The Catalyst Efficiency Monitor uses an oxygen sensor before and after the catalyst to infer the hydrocarbon efficiency based on oxygen storage capacity of the ceria and precious metals in the washcoat. Under normal, closed-loop fuel conditions, high efficiency catalysts have significant oxygen storage. This makes the switching frequency of the rear HO<sub>2</sub>S very slow and reduces the amplitude of those switches as compared to the switching frequency and amplitude of the front HO<sub>2</sub>S. As catalyst efficiency deteriorates due to thermal and/or chemical deterioration, its ability to store oxygen declines. The post-catalyst HO<sub>2</sub>S signal begins to switch more rapidly with increasing amplitude, approaching the switching frequency and amplitude of the pre-catalyst HO<sub>2</sub>S. The predominant failure mode for high mileage catalysts is chemical deterioration (phosphorus deposition on the front brick of the catalyst), not thermal deterioration.

All applications utilize an FTP-based (Federal Test Procedure) catalyst monitor. This simply means that the catalyst monitor must run during a standard FTP emission test as opposed to the 20-second steady-state catalyst monitor used in 1994 through some 1996 vehicles.

### Switch Ratio Method

In order to assess catalyst oxygen storage, the monitor counts front and rear HO<sub>2</sub>S switches during part-throttle, closed-loop fuel conditions after the engine is warmed-up and inferred catalyst temperature is within limits. Front switches are accumulated in up to nine different air mass regions or cells although 5 air mass regions is typical. Rear switches are counted in a single cell for all air mass regions. When the required number of front switches has accumulated in each cell (air mass region), the total number of rear switches is divided by the total number of front switches to compute a switch ratio. A switch ratio near 0.0 indicates high oxygen storage capacity, hence high HC efficiency. A switch ratio near 1.0 indicates low oxygen storage capacity, hence low HC efficiency. If the actual switch ratio exceeds the threshold switch ratio, the catalyst is considered failed.

### General Catalyst Monitor Operation

On some vehicles, if the catalyst monitor does not complete during a particular driving cycle, the already-accumulated switch/signal-length data is retained in Keep Alive Memory and is used during the next driving cycle to allow the catalyst monitor a better opportunity to complete, even under short or transient driving conditions.

Rear HO<sub>2</sub>S sensors can be located in various ways to monitor different kinds of exhaust systems. In-line engines and many V-engines are monitored by individual bank. A rear HO<sub>2</sub>S sensor is used along with the front, fuel-control HO<sub>2</sub>S sensor for each bank. Two sensors are used on an in-line engine; four sensors are used on a V-engine. Some V-engines have exhaust banks that combine into a single underbody catalyst. These systems are referred to as Y-pipe systems. They use only one rear HO<sub>2</sub>S sensor along with the two front, fuel-control HO<sub>2</sub>S sensors. Y-pipe system use three sensors in all. For Y-pipe systems, the two front HO<sub>2</sub>S sensor signals are combined by the software to infer what the HO<sub>2</sub>S signal would have been in front of the monitored catalyst. The inferred front HO<sub>2</sub>S signal and the actual single, rear HO<sub>2</sub>S signal is then used to calculate the switch ratio.

Most vehicles that are part of the "LEV" catalyst monitor phase-in will monitor less than 100% of the catalyst volume – often the first catalyst brick of the catalyst system. Partial volume monitoring is done on LEV and ULEV vehicles in order to meet the 1.75 \* emission-standard. The rationale for this practice is that the catalysts nearest the engine deteriorate first, allowing the catalyst monitor to be more sensitive and illuminate the MIL properly at lower emission standards.

Many applications that utilize partial-volume monitoring place the rear HO<sub>2</sub>S sensor after the first light-off catalyst can or, after the second catalyst can in a three-can per bank system. (A few applications placed the HO<sub>2</sub>S in the middle of the catalyst can, between the first and second bricks.)

Some vehicles may employ an Exponentially Weighted Moving Average (EWMA) algorithm to improve the robustness of the FTP catalyst monitor. During normal customer driving, a malfunction will illuminate the MIL, on average, in 3 to 6 driving cycles. If KAM is reset (battery disconnected), a malfunction will illuminate the MIL in 2 driving cycles. See the section on EWMA for additional information.

<b>CATALYST MONITOR OPERATION:</b>	
DTCs	P0420 Bank 1 (or Y-pipe), P0430 Bank 2
Monitor execution	once per driving cycle
Monitor Sequence	HO2S response test complete and no DTCs (P0133/P0153) prior to calculating switch ratio, no SAIR pump stuck on DTCs (P0412/P1414), no evap leak check DTCs (P0442)
Sensors OK	ECT, IAT, TP, VSS, CKP
Monitoring Duration	Approximately 900 seconds during appropriate FTP conditions (approximately 200 to 600 oxygen sensor switches are collected)

<b>TYPICAL SWITCH RATIO CATALYST MONITOR ENTRY CONDITIONS:</b>		
Entry condition	Minimum	Maximum
Time since engine start-up (70 °F start)	330 seconds	
Engine Coolant Temp	170 °F	230 °F
Intake Air Temp	20 °F	180 °F
Engine Load	10%	
Throttle Position	Part Throttle	Part Throttle
Time since entering closed loop fuel	30 sec	
Vehicle Speed	5 mph	70 mph
Inferred Catalyst Mid-bed Temperature	900 °F	
Steady Air Mass Flow for each Air Mass cell (typically five cells)	1.0 lb/min	5.0 lb/min
(Note: FTP cycle is biased towards the low air mass range, 25 - 35 mph steady state driving must be performed to complete the monitor)		

<b>TYPICAL MALFUNCTION THRESHOLDS:</b>
Rear-to-front O2 sensor switch-ratio > 0.75 (bank monitor)
Rear-to-front O2 sensor switch-ratio > 0.60 (Y-pipe monitor)

<b>J1979 MODE \$06 DATA</b>			
Test ID	Comp ID	Description	Units
\$10	\$11	Bank 1 switch-ratio and max. limit	unitless
\$10	\$21	Bank 2 switch-ratio and max. limit	unitless
Conversion for Test ID \$10: multiply by 0.0156 to get a value from 0 to 1.0			

\*\* NOTE: In this document, a monitor or sensor is considered OK if there are no DTCs stored for that component or system at the time the monitor is running.

## Misfire Monitor

There are two different misfire monitoring technologies used in the 1997 MY. They are Low Data Rate (LDR) and High Data Rate (HDR). The LDR system is capable of meeting the FTP monitoring requirements on most engines and is capable of meeting “full-range” misfire monitoring requirements on 4-cylinder engines. The HDR system is capable of meeting “full-range” misfire monitoring requirements on 6 and 8 cylinder engines. HDR is being phased in on these engines to meet the “full-range” misfire phase-in requirements specified in the OBD-II regulations.

### Low Data Rate System

The LDR Misfire Monitor uses a low-data-rate crankshaft position signal, (i.e. one position reference signal at 10 deg BTDC for each cylinder event). The PCM calculates crankshaft rotational velocity for each cylinder from this crankshaft position signal. The acceleration for each cylinder can then be calculated using successive velocity values. The changes in overall engine rpm are removed by subtracting the median engine acceleration over a complete engine cycle. The resulting deviant cylinder acceleration values are used in evaluating misfire in the “General Misfire Algorithm Processing” section below.

“Profile correction” software is used to “learn” and correct for mechanical inaccuracies in crankshaft tooth spacing under de-fueled engine conditions (requires three 60 to 40 mph no-braking decels after Keep Alive Memory has been reset). These learned corrections improve the high-rpm capability of the monitor for most engines. The misfire monitor is not active until a profile has been learned.

### High Data Rate System

The HDR Misfire Monitor uses a high data rate crankshaft position signal, (i.e. 18 position references per crankshaft revolution [20 on a V-10]). This high-resolution signal is processed using two different algorithms. The first algorithm, called pattern cancellation, is optimized to detect low rates of misfire. The algorithm learns the normal pattern of cylinder accelerations from the mostly good firing events and is then able to accurately detect deviations from that pattern. The second algorithm is optimized to detect “hard” misfires, i.e. one or more continuously misfiring cylinders. This algorithm filters the high-resolution crankshaft velocity signal to remove some of the crankshaft torsional vibrations that degrade signal to noise. This significantly improves detection capability for continuous misfires. Both algorithms produce a deviant cylinder acceleration value, which is used in evaluating misfire in the “General Misfire Algorithm Processing” section below.

Due to the high data processing requirements, the HDR algorithms could not be implemented in the PCM microprocessor. They are implemented in a separate chip in the PCM called an “AICE” chip. The PCM microprocessor communicates with the AICE chip using a dedicated serial communication link. The output of the AICE chip (the cylinder acceleration values) is sent to the PCM microprocessor for additional processing as described below. Lack of serial communication between the AICE chip and the PCM microprocessor, or an inability to synchronize the crank or cam sensors inputs sets a P1309 DTC.

“Profile correction” software is used to “learn” and correct for mechanical inaccuracies in crankshaft tooth spacing under de-fueled engine conditions (requires three 60 to 40 mph no-braking decels after Keep Alive Memory has been reset). If KAM has been reset, the PCM microprocessor initiates a special routine which computes correction factors for each of the 18 (or 20) position references and sends these correction factors back to the AICE chip to be used for subsequent misfire signal processing. These learned corrections improve the high rpm capability of the monitor. The misfire monitor is not active until a profile has been learned.

## Generic Misfire Algorithm Processing

The acceleration that a piston undergoes during a normal firing event is directly related to the amount of torque that cylinder produces. The calculated piston/cylinder acceleration value(s) are compared to a misfire threshold that is continuously adjusted based on inferred engine torque. Deviant accelerations exceeding the threshold are conditionally labeled as misfires.

The calculated deviant acceleration value(s) are also evaluated for noise. Normally, misfire results in a non-symmetrical loss of cylinder acceleration. Mechanical noise, such as rough roads or high rpm/light load conditions, will produce symmetrical acceleration variations. Cylinder events that indicate excessive deviant accelerations of this type are considered noise. Noise-free deviant acceleration exceeding a given threshold is labeled a misfire.

The number of misfires are counted over a continuous 200 revolution and 1000 revolution period. (The revolution counters are not reset if the misfire monitor is temporarily disabled such as for negative torque mode, etc.) At the end of the evaluation period, the total misfire rate and the misfire rate for each individual cylinder is computed. The misfire rate evaluated every 200 revolution period (Type A) and compared to a threshold value obtained from an engine speed/load table. This misfire threshold is designed to prevent damage to the catalyst due to sustained excessive temperature (1600°F for Pt/Pd/Rh conventional washcoat, 1650°F for Pt/Pd/Rh advanced washcoat and 1800°F for Pd-only high tech washcoat). If the misfire threshold is exceeded and the catalyst temperature model calculates a catalyst mid-bed temperature that exceeds the catalyst damage threshold, the MIL blinks at a 1 Hz rate while the misfire is present. If the threshold is again exceeded on a subsequent driving cycle, the MIL is illuminated.

If a single cylinder is determined to be consistently misfiring in excess of the catalyst damage criteria, the fuel injector to that cylinder may be shut off for 30 seconds to prevent catalyst damage. Up to two cylinders may be disabled at the same time. This fuel shut-off feature is used on many 8-cylinder engine and some 6-cylinder engines. It is never used on a 4-cylinder engine. After 30 seconds, the injector is re-enabled. If misfire on that cylinder is again detected after 200 revs (about 5 to 10 seconds), the fuel injector will be shut off again and the process will repeat until the misfire is no longer present. Note that ignition coil primary circuit failures (see CCM section) will trigger the same type of fuel injector disablement.

Next, the misfire rate is evaluated every 1000 rev period and compared to a single (Type B) threshold value to indicate an emission-threshold malfunction, which can be either a single 1000 rev exceedence from startup or a subsequent 1000 rev exceedence on a drive cycle after start-up.

## Profile Correction

"Profile correction" software is used to "learn" and correct for mechanical inaccuracies in the crankshaft position wheel tooth spacing. Since the sum of all the angles between crankshaft teeth must equal 360°, a correction factor can be calculated for each misfire sample interval that makes all the angles between individual teeth equal. To prevent any fueling or combustion differences from affecting the correction factors, learning is done during decel-fuel cutout.

The correction factors are learned during closed-throttle, non-braking, de-fueled decelerations in the 60 to 40 mph range after exceeding 60 mph (likely to correspond to a freeway exit condition). In order to minimize the learning time for the correction factors, a more aggressive decel-fuel cutout strategy may be employed when the conditions for learning are present. The corrections are typically learned in a single deceleration, but can be learned during up to 3 such decelerations. The "mature" correction factors are the average of a selected number of samples. A low data rate misfire system will typically learn 4 such corrections in this interval, while a high data rate system will learn 36 or 40 in the same interval (data is actually processed in the AICE chip). In order to assure the accuracy of these corrections, a tolerance is placed on the incoming values such that an individual correction factor must be repeatable within the tolerance during learning. This is to reduce the possibility of learning corrections on rough road conditions which could limit misfire detection capability.

Since inaccuracies in the wheel tooth spacing can produce a false indication of misfire, the misfire monitor is not active until the corrections are learned. In the event of battery disconnection or loss of Keep Alive Memory the correction factors are lost and must be relearned.

<b>Misfire Monitor Operation:</b>	
DTCs	P0300 to P0310 (general and specific cylinder misfire) P1309 (no cam/crank synchronization, AICE chip malfunction)
Monitor execution	Continuous, misfire rate calculated every 200 or 1000 revs
Monitor Sequence	None
Sensors OK	CKP, CMP
Monitoring Duration	Entire driving cycle (see disablement conditions below)

<b>Typical misfire monitor entry conditions:</b>		
Entry condition	Minimum	Maximum
Time since engine start-up (5 sec or 240 sec on 1996/97 vehicles)	5 seconds	5 seconds
Engine Coolant Temperature	20 °F	250 °F
RPM Range (FTP Misfire certified)	Idle rpm	~ 2500 rpm
RPM Range (Full-Range Misfire certified)	Idle rpm	redline on tach or fuel cutoff
Profile correction factors learned in KAM	Yes	

<b>Typical misfire temporary disablement conditions:</b>
Temporary disablement conditions:
Closed throttle decel (negative torque, engine being driven)
Fuel shut-off due to vehicle-speed limiting or engine-rpm limiting mode
Accessory load-state change (A/C, power steering)
High rate of change of torque (heavy throttle tip-in or tip out)

<b>Typical misfire monitor malfunction thresholds:</b>
Type A (catalyst damaging misfire rate): misfire rate is an rpm/load table ranging from 40% at idle to 4% at high rpm and loads
Type B (emission threshold rate): 1% to 3%



<b>J1979 Mode \$06 Data</b>			
Test ID	Comp ID	Description	Units
\$50	\$00	Total engine misfire rate and emission threshold misfire rate (updated every 1,000 revolutions)	percent
\$53	\$00 - \$0A	Cylinder-specific misfire rate and malfunction threshold misfire rate (either cat damage or emission threshold) (updated when DTC set or clears)	percent
\$54	\$00	Highest catalyst-damage misfire and catalyst damage threshold misfire rate (updated when DTC set or clears)	percent
\$55	\$00	Highest emission-threshold misfire and emission threshold misfire rate (updated when DTC set or clears)	percent
\$56	\$00	Cylinder events tested and number of events required for a 1000 rev test	events
Conversion for Test IDs \$50 through \$55: multiply by 0.000015 to get percent			
Conversion for Test ID \$56: multiply by 1 to get ignition events			

<b>Profile Correction Operation</b>	
DTCs	P1309 – AICE chip communication failure
Monitor Execution	once per KAM reset.
Monitor Sequence:	Profile must be learned before misfire monitor is active.
Sensors OK:	CKP, CMP, no AICE communication errors, CKP/CMP in synch
Monitoring Duration;	10 cumulative seconds in conditions (a maximum of three 60-40 mph defueled decels)

<b>Typical profile learning entry conditions:</b>		
Entry condition	Minimum	Maximum
Engine in decel-fuel cutout mode for 4 engine cycles		
Brakes applied	No	No
Engine RPM	1300 rpm	3700 rpm
Change in RPM		600 rpm/background loop
Vehicle Speed	30 mph	75 mph
Learning tolerance		1%

## AIR System Monitor

The secondary air system utilizes an electric air pump as well as one or two electrically controlled check valves to deliver air into the exhaust manifold. The AIR pump flow check monitors the HO2S signal at idle to determine if secondary air is being delivered into the exhaust system. The air/fuel ratio is commanded open-loop rich, the AIR pump is turned on and the time required for the HO2S signal to go lean is monitored. If the HO2S signal does not go lean within the allowable time limit, a low/no flow malfunction is indicated. (P0411)

The electric air pump draws high current and must be energized through a separate relay. Both the primary and secondary circuits are checked for opens and shorts. First, the output driver within the PCM (primary circuit) is checked for circuit continuity (P0412). This circuit energizes the relay and the control valve(s). Next, a feedback circuit from the secondary side of the relay to the PCM is used to check secondary circuit continuity (P1413, P1414).

AIR Monitor Operation:	
DTCs	P0411 functional check, P0412, P1413, P1414 circuit checks
Monitor execution	Functional - once per driving cycle, circuit checks - continuous
Monitor Sequence	Oxygen sensor monitor complete and OK
Sensors OK	ECT
Monitoring Duration	20 seconds at idle

Typical AIR functional check entry conditions:		
Entry condition	Minimum	Maximum
Time since engine start-up	600 seconds	
Engine Coolant Temp	50 °F	
Short Term Fuel Trim		12.5%
Fuel Tank Pressure		4.5 in H <sub>2</sub> O
Closed Throttle	at idle rpm	at idle rpm
Purge Fuel Flow	0 lb/min	0.2 lb/min
Note: No P0411 DTC is stored if IAT < 20 °F at the start of the functional test although the test runs. (Precludes against identifying a temporary, frozen check valve.)		

Typical AIR functional check malfunction thresholds:
Minimum time allowed for HO2S sensor to indicate lean: < 4 seconds

J1979 Mode \$06 Data			
Test ID	Comp ID	Description	Units
\$30	\$11	HO2S11 voltage for upstream flow test and rich limit	volts
\$30	\$21	HO2S21 voltage for upstream flow test and rich limit	volts
\$31	\$00	HO2S lean time for upstream flow test and time limit	seconds
Conversion for Test ID \$30: multiply by 0.00098 to get volts			
Conversion for Test ID \$31: multiply by 0.125 to get seconds			

## EVAP System Functional Monitor – Purge Valve Functional Check

Non-enhanced evaporative systems use either a Canister Purge Solenoid or a Vapor Management Valve to control purge vapor. These systems are tested differently as described below.

The Vapor Management Valve (VMV) output circuit is checked for opens and shorts internally in the PCM by monitoring the status of the duty-cycled output driver. When the output driver is fully energized, or de-energized, the feedback circuit voltage should respond high or low accordingly (P0443).

The VMV functional check uses the idle airflow correction for the IAC solenoid to check for adequate purge flow. The VMV is a source of engine airflow at idle, therefore, a change in VMV airflow will produce a corresponding change in IAC airflow. The IAC airflow correction is checked while the VMV is normally open (> 75%), then checked again after the VMV is commanded closed (0 %). If the difference in IAC airflow corrections is too small, it indicates inadequate VMV flow (P1443).

### VMV Functional Monitor Operation:

DTCs	P1443 functional check, P0443 circuit check
Monitor execution	Functional check - once per driving cycle, Circuit checks - continuous at 0 and 100% duty cycle
Monitor Sequence	Oxygen sensor monitor complete and OK
Sensors OK	MAF, VSS, ECT, CKP, TP
Monitoring Duration	20 seconds at idle

### Typical VMV functional check entry conditions:

Entry condition	Minimum	Maximum
Intake Air Temp	40 °F	100 °F
Engine Load	20%	35%
Vehicle Speed	0 mph	0 mph
Time at idle	10 seconds	
Time in closed loop fuel	700 seconds	
Change in idle load		< 2%
Purge Duty cycle	75%	100%

### Typical VMV functional check malfunction thresholds:

Increase in idle airflow when VMV closed: < 0.01 lb/min sampled after a 10 second time period

The Canister Purge (CANP) solenoid output circuit is checked for opens and shorts internally in the PCM by monitoring the status of the duty-cycled output driver. When the output driver is fully energized, or de-energized, the feedback circuit voltage should respond high or low accordingly (P0443). The Purge Flow Sensor is checked for circuit continuity (P1444, P1445)

The CANP solenoid functional check uses a Purge Flow Sensor (PFS) to check for adequate purge flow. The PFS voltage is checked when the solenoid valve is normally open (> 75%), then checked when the solenoid valve is commanded closed (0%). Too low a difference between the voltages indicates inadequate canister purge flow or a PFS malfunction (P1443).

<b>CANP Functional Monitor Operation:</b>	
DTCs	P1443 Functional check, P0443 circuit check P1444, P1445 circuit check for purge flow sensor
Monitor execution	Functional check - once per driving cycle, all circuit checks - continuous (0 and 100% duty cycle for CANP solenoid)
Monitor Sequence	Oxygen sensor monitor complete and OK
Sensors OK	VSS, ECT, CKP, TP
Monitoring Duration	10 seconds

<b>Typical CANP functional check entry conditions:</b>		
Entry condition	Minimum	Maximum
Intake Air Temp	40 °F	130 °F
Engine Load	15%	45%
Vehicle Speed	30 mph	70 mph
Time at idle	10 seconds	
Time in closed loop fuel	60 seconds	
Inferred manifold vacuum	4 inches Hg	
Purge Duty cycle	75%	100%

<b>Typical CANP functional check malfunction thresholds:</b>
Change in PFS voltage when CANP solenoid closed: < 0.25 volts sampled after a 5 second time period

## **EVAP System Monitor - 0.040" dia. Leak Check**

Vehicles that meet enhanced evaporative requirements utilize a vacuum-based evaporative system integrity check. The evap system integrity check uses a Fuel Tank Pressure Transducer (FTPT), a Canister Vent Solenoid (CVS) and Fuel Level Input (FLI) along with the Vapor Management Valve (VMV) to find 0.040" diameter or larger evap system leaks.

The evap system integrity test is done under conditions that minimize vapor generation and fuel tank pressure changes due to fuel slosh since these could result in false MIL illumination. The check is run after a 8 hour cold engine soak (engine-off timer), during steady highway speeds at ambient air temperatures (inferred by IAT) between 40 and 100 °F.

The evap system integrity test is done in four phases.

### **(Phase 0 - initial vacuum pulldown):**

First, the Canister Vent Solenoid is closed to seal the entire evap system, then the VMV is opened to pull a 7" H<sub>2</sub>O vacuum. If the initial vacuum could not be achieved, a large system leak is indicated (P0455). This could be caused by a fuel cap that was not installed properly, a large hole, an overfilled fuel tank, disconnected/kinked vapor lines, a Canister Vent Solenoid that is stuck open or a VMV that is stuck closed.

If the initial vacuum is excessive, a vacuum malfunction is indicated (P1450). This could be caused by kinked vapor lines or a stuck open VMV. If a P0455 or P1450 code is generated, the evap test does not continue with subsequent phases of the small leak check, phases 1-4.

### **Phase 1 - Vacuum stabilization**

If the target vacuum is achieved, the VMV is closed and vacuum is allowed to stabilize.

### **Phase 2 - Vacuum hold and decay**

Next, the vacuum is held for a calibrated time and the vacuum level is again recorded at the end of this time period. The starting and ending vacuum levels are checked to determine if the change in vacuum exceeds the vacuum bleed up criteria. Fuel Level Input is used to adjust the vacuum bleed-up criteria for the appropriate fuel tank vapor volume. Steady state conditions must be maintained throughout this bleed up portion of the test. The monitor will abort if there is an excessive change in load, fuel tank pressure or fuel level input since these are all indicators of impending or actual fuel slosh. If the monitor aborts, it will attempt to run again (up to 20 or more times). If the vacuum bleed-up criteria is not exceeded, the small leak test is considered a pass. If the vacuum bleed-up criteria is exceeded on three successive monitoring events, a 0.040 " dia. leak is likely and a final vapor generation check is done to verify the leak, phases 3-4. Excessive vapor generation can cause a false MIL.

### **Phase 3 - Vacuum release**

The vapor generation check is done by releasing any vacuum, then closing the VMV, waiting for a period of time, and determining if tank pressure remains low or if it is rising due to excessive vapor generation

### **Phase 4 - Vapor generation**

If the pressure rise due to vapor generation is below the threshold limit for absolute pressure and change in pressure, a P0442 DTC is stored.

<b>0.040" EVAP Monitor Operation:</b>	
DTCs	P0455 (gross leak), P1450 (excessive vacuum), P0442 (0.040" leak)
Monitor execution	once per driving cycle
Monitor Sequence	HO2S monitor completed and OK
Sensors/Components OK	MAF, IAT, VSS, ECT, CKP, TP, FTP, VMV, CVS
Monitoring Duration	360 seconds (see disablement conditions below)

<b>Typical 0.040" EVAP monitor entry conditions, Phases 0 through 4:</b>		
Entry condition	Minimum	Maximum
Engine off (soak) time	6 – 8 hours	
Time since engine start-up	330 seconds	1800 seconds
Intake Air Temp	40 °F	90 - 100 °F
BARO (<8,000 ft altitude)	22.5 " Hg	
Engine Load	20%	70%
Vehicle Speed	40 mph	75 mph
Purge Duty cycle	75%	100%
Fuel Fill Level	15%	85%
Fuel Tank Pressure Range	- 17 H <sub>2</sub> O	2.5 H <sub>2</sub> O

<b>Typical 0.040" EVAP abort (fuel slosh) conditions for Phase 2:</b>
Change in load: > 20%
Change in tank pressure: > 1 " H <sub>2</sub> O
Change in fuel fill level: > 15%
Number of aborts: > 20 (may be up to 255)

<b>Typical 0.040 EVAP monitor malfunction thresholds:</b>
P1450 (Excessive vacuum): < -8.0 in H <sub>2</sub> O over a 30 second evaluation time.
P0455 (Gross leak): > -8.0 in H <sub>2</sub> O over a 30 second evaluation time.
P0442 (0.040" leak): > 2.5 in H <sub>2</sub> O bleed-up over a 15 second evaluation time at 75% fuel fill. (Note: bleed-up and evaluation times vary as a function of fuel fill level)
P0442 vapor generation limit: < 2.5 in H <sub>2</sub> O over a 120 second evaluation time

**J1979 Mode \$06 Data**

Test ID	Comp ID	Description	Units
\$21	\$00	Initial tank vacuum and minimum limit	in H <sub>2</sub> O
\$21	\$00	Initial tank vacuum and maximum limit Note:	in H <sub>2</sub> O
\$22	\$00	Leak check vacuum bleed-up and threshold	in H <sub>2</sub> O
\$25	\$00	Vapor generation maximum pressure rise	in H <sub>2</sub> O
Conversion for Test IDs \$21 through \$25: If value is > 32,767, the value is negative. Take value, subtract 65,535, and then multiply result by 0.00195 to get inches of H <sub>2</sub> O. If value is <or= 32,767, the value is positive. Multiply by 0.00195 to get inches of H <sub>2</sub> O.			

Additional malfunctions that are be identified during the evaporative system integrity check are as follows:

- The Vapor Management Valve (purge solenoid) output circuit is checked for opens and shorts (P0443), a stuck closed VMV generates a P0455, a leaking or stuck open VMV generates a P1450.
- The Fuel Tank Pressure Transducer input circuit is checked for out of range values (P0452 short, P0453 open). An open power input circuit or stuck check valve generates a P1450.
- The Canister Vent Solenoid output circuit is checked for opens and shorts (P1451), a stuck closed CVS generates a P1450, a leaking or stuck open CVS generates a P0455.
- The Fuel Level Input is checked for out of range values as well as rational readings to determine if it is stuck. (P0460)

<b>EVAP Component Monitor Operation:</b>	
DTCs	P0443, P0452, P0453, P0460
Monitor execution	continuous (5 seconds to identify malfunction or obtain smart driver status)
Monitor Sequence	None
Sensors OK	not applicable
Monitoring Duration	5 seconds for electrical malfunctions

<b>Typical evap component malfunction thresholds:</b>
P0443 (Vapor Management Valve Circuit): open/shorted at 0 and 100% duty cycle
P1451 (Canister Vent Solenoid Circuit): open/shorted
P0452 (Fuel Tank Pressure Sensor Circuit Low): < -17.82 in H <sub>2</sub> O
P0453 (Fuel Tank Pressure Sensor Circuit High): > 16.06 in H <sub>2</sub> O
P0460 (Fuel Level Input Circuit Low): < 5 ohms
P0460 (Fuel Level Input Circuit High): > 200 ohms



## Fuel System Monitor

As fuel system components age or otherwise change over the life of the vehicle, the adaptive fuel strategy learns deviations from stoichiometry while running in closed loop fuel. These learned corrections are stored in Keep Alive Memory as long term fuel trim corrections. They may be stored into an 8x10 rpm/load table or they may be stored as a function of air mass. As components continue to change beyond normal limits or if a malfunction occurs, the long term fuel trim values will reach a calibratable rich or lean limit where the adaptive fuel strategy is no longer allowed to compensate for additional fuel system changes. Long term fuel trim corrections at their limits, in conjunction with a calibratable deviation in short term fuel trim, indicate a rich or lean fuel system malfunction.

Fuel Monitor Operation:	
DTCs	P0171 Bank 1 Lean, P0174 Bank 2 Lean P0172 Bank 1 Rich, P0175 Bank 2 Rich
Monitor execution	continuous while in closed loop fuel
Monitor Sequence	none
Sensors OK	Fuel Rail Pressure (if available)
Monitoring Duration	2 seconds to register malfunction

Typical fuel monitor entry conditions:		
Entry condition	Minimum	Maximum
RPM Range	idle	4,000 rpm
Air Mass Range	0.75 lb/min	8.0 lb/min
Purge Duty cycle	0%	0%

Typical fuel monitor malfunction thresholds:
Long Term Fuel Trim correction cell currently being utilized in conjunction with Short Term Fuel Trim: Lean malfunction: LTFT > 25%, STFT > 5% Rich malfunction: LTFT < 25%, STFT < 10%

## HO2S Monitor

### Front HO2S Signal

The time between HO2S switches is monitored after vehicle startup and during closed loop fuel conditions. Excessive time between switches or no switches since startup indicate a malfunction. Since "lack of switching" malfunctions can be caused by HO2S sensor malfunctions or by shifts in the fuel system, DTCs are stored that provide additional information for the "lack of switching" malfunction. Different DTCs indicate whether the sensor was always indicates lean/disconnected (P1131 P1151), always indicates rich (P1132 P1152), or stopped switching due to excessive long term fuel trim corrections (P1130 P1150, Note: these DTCs are being phased out of production).

HO2S "Lack of Switching" Operation:	
DTCs	P1130 Lack of switching, fuel trim at clip, Bank 1 P1131 Lack of switching, sensor indicates lean, Bank 1 P1132 Lack of switching, sensor indicates rich, Bank 1 P1150 Lack of switching, fuel trim at clip, Bank 2 P1151 Lack of switching, sensor indicates lean, Bank 2 P1152 Lack of switching, sensor indicates rich, Bank 2
Monitor execution	continuous, from startup and while in closed loop fuel
Monitor Sequence	None
Sensors OK	TP, MAF, ECT, IAT, FTP
Monitoring Duration	30 to 60 seconds to register a malfunction

Typical HO2S "Lack of Switching" entry conditions:		
Entry condition	Minimum	Maximum
Closed Loop Requested		
At Part Throttle		
Engine Load	20%	60%
Short Term Fuel Trim	At limits (up to +/- 25 %)	
Time since engine start-up	180 seconds	
Inferred Exhaust Temperature	800 °F	

Typical HO2S "Lack of Switching" malfunction thresholds:
< 5 switches since startup after 30 seconds in test conditions
> 60 seconds since last switch while closed loop
> 30 seconds since last switch while closed loop at Short Term Fuel Trim limit

The HO2S is also tested functionally. The response rate is evaluated by entering a special 1.5 Hz. square wave, fuel control routine. This routine drives the air/fuel ratio around stoichiometry at a calibratable frequency and magnitude, producing predictable oxygen sensor signal amplitude. A slow sensor will show reduced amplitude. Oxygen sensor signal amplitude below a minimum threshold indicates a slow sensor malfunction. (P0133 Bank 1, P0153 Bank 2). If the calibrated frequency was not obtained while running the test because of excessive purge vapors, etc., the test will be run again until the correct frequency is obtained.

<b>HO2S Response Rate Operation:</b>	
DTCs	P0133 (slow response Bank 1) P0153 (slow response Bank 2)
Monitor execution	once per driving cycle
Monitor Sequence	None
Sensors OK	ECT, IAT, MAF, VSS, CKP, TP, CMP, no misfire DTCs, FRP
Monitoring Duration	4 seconds

<b>Typical HO2S response rate entry conditions:</b>		
Entry condition	Minimum	Maximum
Short Term Fuel Trim Range	70%	130%
Engine Coolant Temp	150 °F	240 °F
Intake Air Temp		140 °F
Engine Load	20%	50%
Vehicle Speed	30 mph	60 mph
Engine RPM	1000 rpm	2000 rpm
Time since entering closed loop fuel	10 seconds	

<b>Typical HO2S response rate malfunction thresholds:</b>
Voltage amplitude: < 0.5 volts

<b>J1979 Mode \$06 Data</b>			
Test ID	Comp ID	Description	Units
\$01	\$11	HO2S11 voltage amplitude and voltage threshold	volts
\$01	\$21	HO2S21 voltage amplitude and voltage threshold	volts
\$03	\$01	Upstream O2 sensor switch-point voltage	volts
Conversion for Test IDs \$01 through \$03: multiply by 0.00098 to get volts			

## Rear HO2S Signal

A functional test of the rear HO2S sensors is done during normal vehicle operation. The peak rich and lean voltages are continuously monitored. Voltages that exceed the calibratable rich and lean thresholds indicate a functional sensor. If the voltages have not exceeded the thresholds after a long period of vehicle operation, the air/fuel ratio may be forced rich or lean in an attempt to get the rear sensor to switch. This situation normally occurs only with a green catalyst (< 500 miles). If the sensor does not exceed the rich and lean peak thresholds, a malfunction is indicated.

Rear HO2S Check Operation:	
DTCs	P0136 No activity, Bank 1 P0156 No activity, Bank 2
Monitor execution	once per driving cycle for activity test, continuous for over voltage test
Monitor Sequence	None
Sensors OK	
Monitoring Duration	continuous until monitor completed

Typical Rear HO2S check entry conditions:		
Entry condition	Minimum	Maximum
Inferred exhaust temperature range	400 °F	1400 °F
Rear HO2S heater-on time	120 seconds	
Throttle position	part throttle	
Engine RPM (forced excursion only)	1000 rpm	2000 rpm

Typical Rear HO2S check malfunction thresholds:
Does not exceed rich and lean threshold envelope: Rich < 0.25 to 0.50 volts Lean > 0.40 to 0.65 volts

J1979 Mode \$06 Data			
Test ID	Comp ID	Description	Units
\$03	\$02	Downstream O2 sensor switch-point voltage	volts
Conversion for Test ID \$03: multiply by 0.00098 to get volts			

## HO2S Heaters, front and rear

The HO2S heaters are monitored for proper voltage and current. A HO2S heater voltage fault is determined by turning the heater on and off and looking for corresponding voltage change in the heater output driver circuit in the PCM.

A separate current-monitoring circuit monitors heater current once per driving cycle. The heater current is actually sampled three times. If the current value for two of the three samples falls below a calibratable threshold, the heater is assumed to be degraded or malfunctioning. (Multiple samples are taken for protection against noise on the heater current circuit.)

HO2S Heater Monitor Operation:	
DTCs	Bank 1 - P0135 Front, P0141 Rear Bank 2 - P0155 Front, P0161 Rear
Monitor execution	once per driving cycle for heater current, continuous for voltage monitoring
Monitor Sequence	heater voltage check is done prior to heater current check
Sensors OK	
Monitoring Duration	< 5 seconds

Typical HO2S heater monitor entry conditions:		
Entry condition	Minimum	Maximum
Inferred exhaust temperature range	250 °F	1400 °F
HO2S heater-on time	120 seconds	

Typical HO2S heater check malfunction thresholds:	
Smart driver status indicated malfunction	
Heater current outside limits:	< 0.220 amps or > 3 amps, (NTK) < 0.400 amps or > 3 amps, (Bosch)

## DPFE EGR System Monitor

The Delta Pressure Feedback EGR system is a closed loop EGR control system that uses Delta Pressure Feedback EGR sensor (DPFE) to measure EGR flow across an orifice in the EGR tube. When the EGR valve is open, a pressure differential is created across the orifice and measured by the DPFE sensor. This DPFE measurement is used to control the EGR vacuum regulator (EVR), which provides vacuum to open and modulate the EGR valve itself.

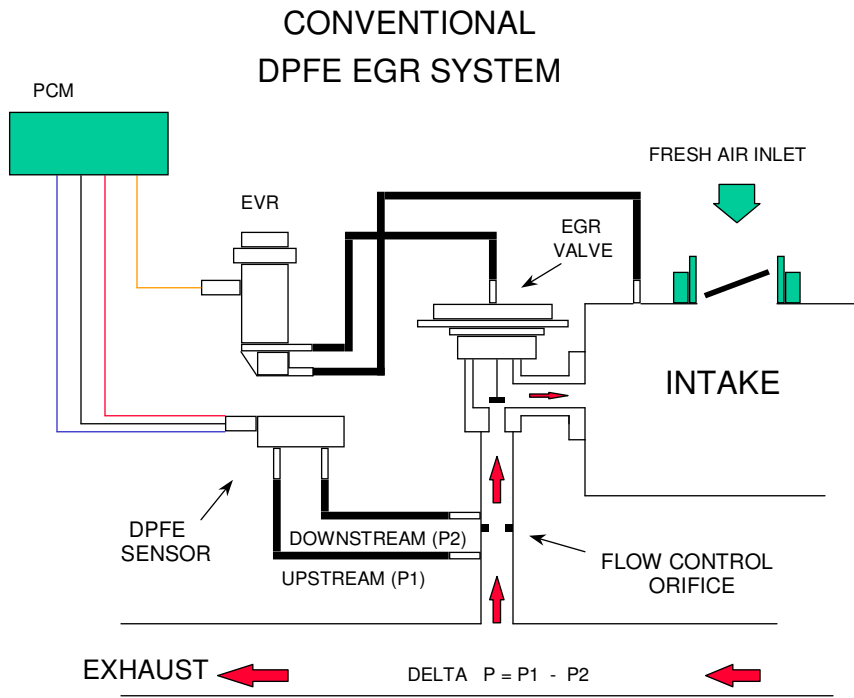

The Delta Pressure Feedback EGR Monitor is a series of electrical tests and functional tests that monitor various aspects of EGR system operation.

First, the Delta Pressure Feedback EGR (DPFE) sensor input circuit is checked for out of range values (P1400 P1401). The Electronic Vacuum Regulator (EVR) output circuit is checked for opens and shorts (P1409).

<b>EGR Electrical Check Operation:</b>	
DTCs	P1400, P1401, P1409
Monitor execution	Continuous, during EGR monitor
Monitor Sequence	None
Sensors OK	
Monitoring Duration	4 seconds to register a malfunction

<b>Typical EGR electrical check entry conditions:</b>
EGR system enabled

<b>Typical EGR electrical check malfunction thresholds:</b>
DPFE sensor outside voltage: > 4.96 volts, < 0.195 volts
EVR solenoid smart driver status indicates open/short

Note: EGR normally has large amounts of water vapor that are the result of the engine combustion process. During cold ambient temperatures, under some circumstances, water vapor can freeze in the DPFE sensor, hoses, as well as other components in the EGR system. In order to prevent MIL illumination for temporary freezing, the following logic is used:

If an EGR system malfunction is detected above 32 °F, the EGR system and the EGR monitor is disabled for the current driving cycle. A DTC is stored and the MIL is illuminated if the malfunction has been detected on two consecutive driving cycles.

If an EGR system malfunction is detected below 32 °F, only the EGR system is disabled for the current driving cycle. A DTC is not stored and the I/M readiness status for the EGR monitor will not change. The EGR monitor, however, will continue to operate. If the EGR monitor determined that the malfunction is no longer present (i.e., the ice melts), the EGR system will be enabled and normal system operation will be restored.

After the vehicle is started, during vehicle acceleration, the differential pressure indicated by the DPFE sensor at zero EGR flow is checked to ensure that both hoses to the DPFE sensor are connected. Under this condition, the differential pressure should be zero. If the differential pressure indicated by the DPFE sensor exceeds a maximum threshold or falls below a minimum threshold, an upstream or downstream DPFE hose malfunction is indicated (P1405 P1406).

<b>DPFE EGR Hose Check Operation:</b>	
DTCs	P1405, P1406
Monitor execution	once per driving cycle
Monitor Sequence	Done after P0402 test
Sensors OK	MAF
Monitoring Duration	2 seconds to register a malfunction

<b>Typical DPFE EGR hose check entry conditions:</b>		
Entry Condition	Minimum	Maximum
EVR dutycycle (EGR commanded off)	0%	0%
Mass Air Flow		8 lb/min
Inferred exhaust backpressure	13 in H <sub>2</sub> O	

<b>Typical EGR hose check malfunction thresholds:</b>
DPFE sensor voltage: < 7 in H <sub>2</sub> O, > 7 in H <sub>2</sub> O

<b>J1979 Mode \$06 Data</b>			
Test ID	Comp ID	Description	Units
\$41	\$11	Delta pressure for upstream hose test and threshold	in. H <sub>2</sub> O
\$41	\$12	Delta pressure for downstream hose test and threshold	in. H <sub>2</sub> O
Conversion for Test ID \$41: If value is > 32,767, the value is negative. Take value, subtract 65,536, and then multiply result by 0.0078 to get inches of H <sub>2</sub> O. If value is <or= 32,767, the value is positive. Multiply by 0.0078 to get inches of H <sub>2</sub> O			



After the vehicle has warmed up and normal EGR rates are being commanded by the PCM, the low flow check is performed. Since the EGR system is a closed loop system, the EGR system will deliver the requested EGR flow as long as it has the capacity to do so. If the EVR duty cycle is very high (greater than 80% duty cycle), the differential pressure indicated by the DPFE sensor is evaluated to determine the amount of EGR system restriction. If the differential pressure is below a calibratable threshold, a low flow malfunction is indicated (P0401).

<b>EGR Flow Check Operation:</b>	
DTCs	P0401
Monitor execution	once per driving cycle
Monitor Sequence	Done after P1405 and P1406 tests
Sensors OK	CKP, ECT, IAT, MAF, TP
Monitoring Duration	70 seconds to register a malfunction

<b>Typical EGR flow check entry conditions:</b>			
Entry Condition	Minimum	Maximum	
EVR Dutycycle	80%	100%	
Engine RPM		2500 rpm	
Mass Air Flow Rate of Change		6% program loop	
Inferred manifold vacuum	6 in Hg	10 in Hg	

<b>Typical EGR flow check malfunction thresholds:</b>
DPFE sensor voltage: < 6 in H <sub>2</sub> O

<b>J1979 Mode \$06 Data</b>			
Test ID	Comp ID	Description	Units
\$4A	\$30	Delta pressure for flow test and threshold	in. H <sub>2</sub> O
\$4B	\$30	EVR dutycycle for flow test and threshold	percent
Conversion for Test ID \$4A: If value is > 32,767, the value is negative. Take value, subtract 65,536, and then multiply result by 0.0078 to get inches of H <sub>2</sub> O. If value is <or= 32,767, the value is positive. Multiply by 0.0078 to get inches of H <sub>2</sub> O			
Conversion for Test ID \$4B: multiply by 0.0000305 to get percent dutycycle.			

Finally, the differential pressure indicated by the DPFE sensor is also checked at idle with zero requested EGR flow to perform the high flow check. If the differential pressure exceeds a calibratable limit, it indicates a stuck open EGR valve or debris temporarily lodged under the EGR valve seat (P0402).

<b>EGR Stuck open Check Operation:</b>	
DTCs	P0402
Monitor execution	once per driving cycle
Monitor Sequence	Done after P1400 and P1401 tests
Sensors OK	CPS, ECT, IAT, MAF, TP
Monitoring Duration	10 seconds to register a malfunction

<b>Typical EGR stuck open check entry conditions:</b>		
Entry Condition	Minimum	Maximum
EVR dutycycle (EGR commanded off)	0%	0%
Engine RPM (after EGR enabled)	at idle	idle

<b>Typical EGR stuck open check malfunction thresholds:</b>
DPFE sensor voltage at idle versus engine-off signal: > 0.6 volts

<b>J1979 Mode \$06 Data</b>			
Test ID	Comp ID	Description	Units
\$45	\$20	Delta pressure for stuck open test and threshold	volts
Conversion for Test ID \$45: Multiply by 0.0156 to get A/D counts (0-1024) or 0.0000763 to get voltage			

## I/M Readiness Indication

If the inferred ambient temperature is less than 32 °F, or greater than 140 °F, or the altitude is greater than 8,000 feet (BARO < 22.5 "Hg), the EGR monitor cannot be run reliably. In these conditions, a timer starts to accumulate the time in these conditions. If the vehicle leaves these extreme conditions, the timer starts decrementing, and, if conditions permit, will attempt to complete the EGR flow monitor. If the timer reaches 500 seconds, the EGR monitor is disabled for the remainder of the current driving cycle and the EGR Monitor I/M Readiness bit will be set to a "ready" condition after one such driving cycle.

# Comprehensive Component Monitor - Engine

## Engine Inputs

Analog inputs such as Intake Air Temperature (P0112, P0113), Engine Coolant Temperature (P0117, P0118), Cylinder Head Temperature (P1289, P1290), Mass Air Flow (P0102, P0103) and Throttle Position (P0122, P0123, P1120), Fuel Temperature (P0182, P0183) are checked for opens, shorts, or out-of-range values by monitoring the analog -to-digital (A/D) input voltage.

### Analog Sensor Check Operation:

DTCs	P0112, P0113, P0117, P0118, P0102, P0103, P0122, P0123, P1289, P1290
Monitor execution	continuous
Monitor Sequence	none
Sensors OK	not applicable
Monitoring Duration	5 seconds to register a malfunction

### Typical analog sensor check malfunction thresholds:

Voltage < 0.20 volts or voltage > 4.80 volts

The MAF and TP sensors are cross-checked to determine whether the sensor readings are rational and appropriate for the current operating conditions. (P1121/P0068)

### MAF/TP Rationality Check Operation:

DTCs	P1121
Monitor execution	Continuous
Monitor Sequence	None
Sensors OK	
Monitoring Duration	3 seconds within test entry conditions

### Typical MAF/TP rationality check entry conditions:

Entry Condition	Minimum	Maximum
Engine RPM	1000 rpm	minimum of 3800 rpm
Engine Coolant Temp	100 °F	

### Typical MAF/TP rationality check malfunction thresholds:

Load > 60% and TP < 2.4 volts  
 Load < 30% and TP > 2.4 volts

The ECT warm-up time is also monitored. If ECT fails to reach a minimum temperature (140 °F) within a specified time period, an "insufficient temp for closed loop" malfunction is indicated (P0125).

## **Ignition**

Distributor Ignition systems (TFI) are no longer in production. Electronic Ignition systems (Electronic Distributorless Ignition System - EDIS or Coil on Plug - COP) systems are being used on all applications.

The EDIS system uses a chip to process the 36 (or 40) tooth crankshaft position signal, generate a low data rate PIP signal for the PCM microprocessor and control a 4 or 6 terminal coil pack which fires a pair of spark plugs. One of these sparkplugs is on the compression stroke, while the other is on the exhaust stroke. The EDIS chip can be incorporated within the PCM or in a separate ignition control module.

The COP system also uses an EDIS chip in the same way as described above, however, each sparkplug has it's own coil which is fired only once on the compression stroke.

The ignition system is checked by monitoring three ignition signals during normal vehicle operation:

Profile Ignition Pickup (CKP, commonly known as PIP), the timing reference signal derived from the crankshaft 36-tooth wheel and processed by the EDIS chip. PIP is a 50% duty cycle, square wave signal that has a rising edge at 10 deg BTDC.

Camshaft IDentification (CMP, commonly known at CID), a signal derived from the camshaft to identify the #1 cylinder

Ignition Diagnostic Monitor (IDM), a signal that indicates that the primary side of the coil has fired. This signal is received as a digital pulse width signal from the EDIS chip. The EDIS chip determines if the current flow to the ignition coil reaches the required current (typically 5.5 Amps for COP, 3.0 to 4.0 Amps for DIS) within a specified time period (typically > 200 microseconds for both COP and DIS). The EDIS chip also outputs status information when the engine is not running.

First, the relationship between successive PIP events is evaluated to determine whether the PIP signal is rational. Too large a change in 3 successive PIP indicates a missing or noisy PIP signal (P0320). Next, the CMP edge count is compared to the PIP edge count. If the proper ratio of CMP events to PIP events is not being maintained (for example, 1 CMP edge for every 8 PIP edges for an 8-cylinder engine), it indicates a missing or noisy CMP signal (P0340). Finally, the relationship between IDM edges and PIP edges is evaluated. If there is not an IDM edge (coil firing) for every PIP edge (commanded spark event), the PCM will look for a pattern of failed IDM events to determine which ignition coil has failed. If the ignition coil cannot be identified or if the engine is running and there are no IDM edges, the IDM circuit is malfunctioning (P1351).

<b>Ignition System Check Operation:</b>	
DTCs	P0320 (CKP), P0340 (CMP) P0351 - P0360 (Coil primary)
Monitor execution	continuous
Monitor Sequence	none
Sensors OK	
Monitoring Duration	< 5 seconds

<b>Typical ignition check entry conditions:</b>		
Entry Condition	Minimum	Maximum
Engine RPM for CKP, CMP	200 rpm	
Engine RPM for coil primary	200 rpm	minimum of 3200 rpm

<b>Typical ignition check malfunction thresholds:</b>
For PIP: Time between PIP edges: > 350 milliseconds Ratio of current PIP period to last two periods: < 0.75, > 1.75 For CMP: Ratio of PIP events to CMP events: 4:1, 6:1, 8:1 or 10:1 based on engine cyl. For coils: Ratio of PIP events to IDM events: 1:1

If an ignition coil primary circuit failure is detected for a single cylinder or coil pair, the fuel injector to that cylinder or cylinder pair will be shut off for 30 seconds to prevent catalyst damage. Up to two cylinders may be disabled at the same time on 6 and 8 cylinder engines and one cylinder is disabled on 4 cylinder engines. After 30 seconds, the injector is re-enabled. If an ignition coil primary circuit failure is again detected, (about 0.10 seconds), the fuel injector will be shut off again and the process will repeat until the fault is no longer present. Note that engine misfire can trigger the same type of fuel injector disablement.

## Engine Outputs

The Idle Air Control (IAC) solenoid is checked electrically for open and shorts (P1504 or P0511) and is functionally checked by monitoring the closed loop idle speed correction required to maintain the desired idle rpm. If the proper idle rpm cannot be maintained and the system has a high rpm (+100) or low rpm error (-200) greater than the malfunction threshold, an IAC malfunction is indicated. (P1506 or P0507, P1507 or P0506)

IAC Check Operation:	
DTCs	P1504 (opens/shorts) P1506 (functional - overspeed) P1507 (functional - underspeed)
Monitor execution	once per driving cycle
Monitor Sequence	None
Sensors OK	
Monitoring Duration	30 seconds

Typical IAC functional check entry conditions:		
Entry Condition	Minimum	Maximum
Engine Coolant Temp	150 °F	
Time since engine start-up	30 seconds	
Closed loop fuel	Yes	
Throttle Position (at idle, closed throttle, no dashpot)	Closed	Closed

Typical IAC functional check malfunction thresholds:
For underspeed error: Actual rpm 100 rpm below target, closed-loop IAC correction > 1 lb/min
For overspeed error: Actual rpm 200 rpm above target, closed-loop IAC correction < .2 lb/min

The Intake Manifold Runner Control (IMRC) is a system which uses dual intake runners to supply air to each cylinder. The secondary runners are normally closed, but the PCM opens them under high rpm conditions when the driver is demanding additional power from the engine. The IMRC system can be actuated using a single electric motor or dual vacuum motors. The IMRC system is functionally checked by monitoring the runner control plates using switches. If the actual position of the runner control plates does not match the commanded position, a malfunction of the IMRC system is indicated.

<b>IMRC System Check Operation:</b>	
DTCs	P1516 - IMRC input switch electrical check, Bank 1 P1517 - IMRC input switch electrical check, Bank 2 P1520 - IMRC output electrical check P1518 - IMRC stuck open, electric operated P1537 – IMRC stuck open, vacuum operated, Bank 1 P1538 – IMRC stuck open, vacuum operated, Bank 2
Monitor execution	continuous
Monitor Sequence	None
Sensors OK	
Monitoring Duration	5 seconds

<b>Typical IMRC functional check malfunction thresholds</b>
IMRC plates do not match commanded position (functional) IMRC switches open/shorted (electrical)

Camshaft Position Control (also known as Variable Cam Timing) is a system that is able to advance and retard camshaft timing relative to the crankshaft. This phasing is controlled by a duty-cycled output. The output driver is checked electrically for opens and shorts (P1380). The system is checked functionally by monitoring the closed loop phase control correction. If the proper phasing cannot be maintained and the system has an advance or retard error greater than the malfunction threshold, a CPC control malfunction is indicated (P1381 or P1383).

<b>Camshaft Position Control System Check Operation:]</b>	
DTCs	P1380 (CPC output electrical check) P1381 (CPC timing over-advanced functional check) P1383 (CPC timing over-retarded functional check)
Monitor execution	Continuous
Monitor Sequence	ECT > 150 °F
Sensors OK	
Monitoring Duration	5 seconds

<b>Typical CPC functional check malfunction thresholds:</b>
timing over-advanced/over-retarded by > 10 crankshaft degrees

# Comprehensive Component Monitor - Transmission

## General

The MIL is illuminated for all emissions related electrical component malfunctions. For malfunctions attributable to a mechanical component (such as a clutch, gear, band, valve, etc.), some transmissions are capable of not commanding the mechanically failed component and providing the remaining maximum functionality (functionality is reassessed on each power up)- in such case a non-MIL Diagnostic Trouble Code (DTC) will be stored and, if so equipped, a Transmission Control Indicator Light (TCIL) will flash.

## Transmission Inputs

Transmission Range Sensor Check Operation:	
DTCs	P0708, P0705 (open/invalid pattern for digital TRS) P0707, P0708 (opens/shorts for analog TRS)
Monitor execution	Continuous
Monitor Sequence	None
Sensors OK	
Monitoring Duration	30 seconds

Typical TRS check entry conditions:		
Auto Transmission Entry Conditions	Minimum	Maximum
Gear selector position	each position for up to 30 seconds	480 seconds

Typical TRS malfunction thresholds:	
For digital sensor:	Invalid pattern from 3 or 5 digital inputs and/or 1 analog circuit open for 5 seconds
For analog sensor:	Voltage > 4.8 volts or < 0.2 voltage for 5 seconds



<b>Vehicle Speed Sensor Functional Check Operation:</b>	
DTCs	P0500
Monitor execution	Continuous
Monitor Sequence	None
Sensors OK	
Monitoring Duration	30 seconds

<b>Typical VSS functional check entry conditions:</b>		
Auto Transmission Entry Conditions	Minimum	Maximum
Gear selector position	drive	
Engine rpm (above converter stall speed) OR	3000 rpm	
Turbine shaft rpm (if available) OR	1500 rpm	
Output shaft rpm	650 rpm	
Vehicle speed (if available)	15 mph	
Manual Transmission Entry Conditions		
Engine load	50 %	
Engine rpm	2400 rpm	

<b>Typical VSS functional check malfunction thresholds:</b>
Vehicle is inferred to be moving with positive driving torque and VSS is < 1 - 5 mph for 5 seconds

<b>Output Shaft Speed Sensor Functional Check Operation:</b>	
DTCs	P0720
Monitor execution	continuous
Monitor Sequence	none
Sensors OK	
Monitoring Duration	30 seconds

<b>Typical OSS functional check entry conditions:</b>		
Auto Transmission Entry Conditions	Minimum	Maximum
Gear selector position	drive	
Engine rpm (above converter stall speed) OR	3000 rpm	
Turbine shaft rpm (if available) OR	1500 rpm	
Output shaft rpm	650 rpm	
Vehicle speed (if available)	15 mph	

<b>Typical OSS functional check malfunction thresholds:</b>
Vehicle is inferred to be moving with positive driving torque and OSS < 100 to 200 rpm for 5 seconds

<b>Turbine Shaft Speed Sensor Functional Check Operation:</b>	
DTCs	P0715
Monitor execution	continuous
Monitor Sequence	none
Sensors OK	
Monitoring Duration	30 seconds

<b>Typical TSS functional check entry conditions:</b>		
Auto Transmission Entry Conditions	Minimum	Maximum
Gear selector position	drive	
Engine rpm (above converter stall speed) OR	3000 rpm	
Turbine shaft rpm (if available) OR	1500 rpm	
Output shaft rpm	650 rpm	
Vehicle speed (if available)	15 mph	
Torque converter lock-up (some applications)	3 <sup>rd</sup> gear only	

<b>Typical TSS functional check malfunction thresholds:</b>
vehicle is inferred to be moving with positive driving torque and TSS < 200 rpm for 5 seconds

<b>Transmission Fluid Temperature Sensor Functional Check Operation:</b>	
DTCs (non-MIL)	P0712, P0713 (open/short) P1713,(stuck low), P1718 (stuck high)
Monitor execution	continuous
Monitor Sequence	none
Sensors OK	(ECT substituted if TFT has malfunction)
Monitoring Duration	5 seconds for electrical, 600 seconds for functional check

<b>Typical TFT functional check entry conditions:</b>		
Auto Transmission Entry Conditions	Minimum	Maximum
Engine Coolant Temp (hot or cold, not midrange)	> 100 °F	< 20 °F
Time in run mode	500 sec	
Time in gear, vehicle moving, positive torque	150 sec	
Time with engine off (soak time)	420 min	
Vehicle Speed	15 mph	

<b>Typical TFT malfunction thresholds:</b>
Electrical check: TFT voltage <0.05 or > 4.6 volts for 5 seconds TFT functional check (TFT stuck at high temperature or stuck at low temperature): < 6 °F rise or fall in TFT after startup

## Transmission Outputs

Shift Solenoid Check Operation:	
DTCs	SS A - P0750 electrical, P1714 ISIG functional, or P0751 mechanical functional SS B - P0755 electrical, P1715 ISIG functional, or P0756 mechanical functional SS C - P0760 electrical, P1716 ISIG functional, or P0761 mechanical functional SS D - P0765 electrical, P1717 ISIG functional, or P0766 mechanical functional SS E - P0770 electrical, or P0771 mechanical functional
Monitor execution	electrical - continuous, functional - during off to on solenoid transitions
Monitor Sequence	None
Sensors OK	
Monitoring Duration	10 solenoid events

Typical Shift Solenoid ISIG functional check entry conditions:		
Entry Conditions	Minimum	Maximum
Transmission Fluid Temp	70 °F	225 °F
Throttle position	positive drive torque (actual TP varies)	

Typical Shift Solenoid mechanical functional check entry conditions:		
Entry Conditions (with turbine speed)	Minimum	Maximum
Gear ratio calculated	each gear	
Throttle position	positive drive torque	

Typical Shift Solenoid mechanical functional check entry conditions:		
Entry Conditions (without turbine speed)	Minimum	Maximum
Rpm drop is obtained	each shift	
Throttle position	positive drive torque	

Typical SS malfunction thresholds:
Electrical check: Output driver feedback circuit does not match commanded driver state for 5 seconds
ISIG functional check: ISIG chip hardware circuit does not detect characteristic current dip and rise produced by solenoid movement.
Mechanical functional check: Actual obtained gear or shift pattern indicates which shift solenoid is stuck on or off.

<b>Torque Converter Clutch Check Operation:</b>	
DTCs	P0743 electrical, P1740 ISIG functional, or P1744 mechanical functional P1742 mechanical functional, stuck on
Monitor execution	electrical - continuous, mechanical - during lockup
Monitor Sequence	none
Sensors OK	VSS
Monitoring Duration	5 lock-up events

<b>Typical Torque Converter Clutch ISIG functional check entry conditions:</b>		
Entry Conditions	Minimum	Maximum
Transmission Fluid Temp	70 °F	225 °F
Engine Torque	positive drive torque	
Commanded TCC dutycycle for 0 rpm slip	60%	90%

<b>Typical Torque Converter Clutch mechanical functional check entry conditions:</b>		
Entry Conditions	Minimum	Maximum
Throttle Position	steady	
Engine Torque	positive drive torque	
Transmission Fluid Temp	70 °F	225 °F
Commanded TCC dutycycle (0 rpm slip)	60%	100%
Not shifting		

<b>Typical TCC malfunction thresholds:</b>
<p>Electrical check:</p> <p>Output driver feedback circuit does not match commanded driver state for 5 seconds(&gt; 1.0 volt if commanded on, &lt; 2.0 volts if commanded off.)</p> <p>ISIG functional check:</p> <p>ISIG chip hardware circuit does not detect characteristic current dip and rise produced by solenoid movement.</p> <p>Mechanical check:</p> <p>Slip across torque converter &gt; 100 rpm or (on some applications) speed ratio &lt; 0.93</p> <p>Mechanical check:</p> <p>Slip across torque converter &lt; 20 rpm with converter commanded off (some applications)</p>

**Electronic Pressure Control Check Operation:**

DTCs	P1747 electrical,
Monitor execution	Continuous
Monitor Sequence	None
Sensors OK	
Monitoring Duration	5 seconds,

**Typical EPC malfunction thresholds:**

Electrical check:

Current feedback circuit is less than commanded current for 5 seconds

**Inductive Signature Chip Communication Check Operation:**

DTCs	P1636 loss of communication
Monitor execution	off-to-on solenoid transitions
Monitor Sequence	none
Sensors OK	
Monitoring Duration	< 100 solenoid events

**Typical Inductive Signature Chip Communication Check entry conditions:**

Entry Conditions	Minimum	Maximum
Transmission Fluid Temp	70 °F	225 °F
Solenoid commanded off duration		< 2 seconds

**Typical Inductive Signature Communication Chip malfunction thresholds:**

Checksum error, chip not responding

## 4R70W (RWD) Transmission

(no turbine speed sensor)

### Transmission Inputs

The Analog Transmission Range (TR) sensor provides a single analog input to the PCM. The voltage corresponds to the driver-selected gear position (Park, Rev, Neutral, OD, 2, 1). This input is checked for opens, shorts, or out-of-range values. (P0707, P0708)

The Digital Transmission Range (DTR) sensor provides a single analog and three digital inputs to the PCM. The PCM decodes the inputs to determine the driver-selected gear position (Park, Rev, Neutral, OD, 2, 1). This input device is checked for opens and invalid input patterns. (P0708 P0705)

The Vehicle Speed Sensor (VSS) and Output Shaft Speed (OSS) sensor, if equipped, are inputs that are checked for rationality. If the engine rpm is above the torque converter stall speed and engine load is high, it can be inferred that the vehicle must be moving. If there is insufficient output from the VSS sensor, a malfunction is indicated (P0500). If there is insufficient output from the OSS sensor, a malfunction is indicated (P0720).

### Transmission Outputs

#### Shift Solenoids

The Shift Solenoid (SSA and SSB) output circuits are checked for opens and shorts by the PCM by monitoring the status of a feedback circuit from the output driver (P0750 SSA, P0755 SSB).

The shift solenoids are also checked functionally. Since the 4R70W does not have a turbine speed sensor, gear changes are evaluated by observing the rpm drop that occurs when a shift is commanded. Under steady throttle conditions, the 1-2, 2-3 and 3-4 shifts are evaluated. A missing drop in rpm for a commanded shift is recorded in order to obtain the actual gear pattern during an up-shift sequence. This information is used to determine which shift solenoid is malfunctioning. For example, if SS1 is shorted to power or is hydraulically stuck in that position, the 1-2-3-4 commanded shifts will actually result in a 1-1-4-4 shift pattern. The unique shift pattern is used to determine which shift solenoid is malfunctioning. (P0751 SSA, P0756 SSB)

Some vehicle applications will utilize an inductive signature circuit to monitor the shift solenoids functionally. The ISIG circuit monitors the current signature of the shift solenoid as the solenoid is commanded on. A solenoid that functions properly will show a characteristic decrease in current as the solenoid starts to move. If the solenoid is malfunctioning, the current will not change (P1714 SSA, P1715 SSB).

#### Torque Converter Clutch

The Torque Converter Clutch (TCC) output circuit is a duty-cycled output that is checked electrically for opens and shorts by the PCM by monitoring the status of a feedback circuit from the output driver (P0743).

The TCC solenoid is checked functionally by evaluating torque converter slip under steady state conditions when the torque converter is fully applied. If the slip exceeds the malfunction thresholds when the TCC is commanded on, a TCC malfunction DTC is stored (P1744). If there is no slip when the TCC is commanded off, a TCC malfunction DTC is stored (P1742).

Some vehicle applications will utilize an inductive signature circuit to monitor the torque converter clutch. The ISIG circuit monitors the current signature of the TCC solenoid as the solenoid is commanded on. A solenoid that functions properly will show a characteristic decrease in current as the solenoid starts to move. If the solenoid is malfunctioning, the current will not change (P1740). In some applications, the ISIG test is run in conjunction with the other transmission functional tests.

## Electronic Pressure Control

The EPC solenoid is a variable force solenoid that controls line pressure in the transmission. The EPC solenoid has a feedback circuit in the PCM that monitors EPC current. If the current indicates a short to ground (low pressure), engine torque may be reduced to prevent damage to the transmission. (P1747, PCA)



## **AX4S/AX4N (FWD) Transmission**

(has turbine speed sensor)

### **Transmission Inputs**

The Analog Transmission Range (TR) sensor provides a single analog input to the PCM. The voltage corresponds to the driver-selected gear position (Park, Rev, Neutral, OD, 2, 1). This input is checked for opens, shorts, or out-of-range values. (P0707, P0708)

The Digital Transmission Range (DTR) sensor provides a single analog and three digital inputs to the PCM. The PCM decodes the inputs to determine the driver-selected gear position (Park, Rev, Neutral, OD, D, 1). This input device is checked for opens and invalid input patterns. (P0708 P0705)

The Vehicle Speed Sensor (VSS), Turbine Shaft Speed (TSS) sensor and Output Shaft Speed (OSS) sensor, if equipped, are analog inputs that are checked for rationality. If the engine rpm is above the torque converter stall speed and engine load is high, it can be inferred that the vehicle must be moving. If there is insufficient output from the VSS sensor, a malfunction is indicated (P0500). If there is insufficient output from the TSS sensor, a malfunction is indicated (P0715). If there is insufficient output from the OSS sensor, a malfunction is indicated (P0720).

### **Transmission Outputs**

#### Shift Solenoids

The Shift Solenoid (SSA SSB and SSC) output circuits are checked for opens and shorts by the PCM by monitoring the status of a feedback circuit from the output driver (P0750 SSA, P0755 SSB, P0760 SSC).

The shift solenoids are also checked functionally. Since the AX4S and AX4N transmissions do have a turbine speed sensor, the actual gear ratio can be computed any time the transmission is not shifting and the vehicle is not coasting. An actual gear ratio is computed in each gear and compared to the predicted gear ratio in order to determine the actual gear pattern obtained during an up-shift sequence. This information is then used to determine which shift solenoid is malfunctioning. For example, if SS1 is shorted to power or is hydraulically stuck in that position, the 1-2-3-4 commanded shifts will actually result in a 2-2-4-4 shift pattern. The unique shift pattern is used to determine which shift solenoid is malfunctioning. (P0751 SSA, P0756 SSB, P0761 SSC)

#### Torque Converter Clutch

The Torque Converter Clutch (TCC) output circuit is a duty-cycled output that is checked electrically for opens and shorts by the PCM by monitoring the status of a feedback circuit from the output driver (P0743).

The TCC solenoid is checked functionally by evaluating torque converter slip under steady state conditions when the torque converter is fully applied. If the slip exceeds the malfunction thresholds when the TCC is commanded on, a TCC malfunction is indicated (P1744). If there is no slip when the TCC is commanded off, a TCC malfunction is indicated (P1742).

#### Electronic Pressure Control

The EPC solenoid is a variable force solenoid that controls line pressure in the transmission. The EPC solenoid has a feedback circuit in the PCM that monitors EPC current. If the current indicates a short to ground (low pressure), engine torque may be reduced to prevent damage to the transmission. (P1747, PCA)

## **CD4E (FWD) Transmission**

(has turbine speed sensor)

### **Transmission Inputs**

The Analog Transmission Range (TR) sensor provides a single analog input to the PCM. The voltage corresponds to the driver-selected gear position (Park, Rev, Neutral, OD, 2, 1). This input is checked for opens and shorts. (P0707, P0708)

The Vehicle Speed Sensor (VSS) and Turbine Shaft Speed (TSS) sensor are analog inputs that are checked for rationality. If the engine rpm is above the torque converter stall speed and engine load is high, it can be inferred that the vehicle must be moving. If there is insufficient output from the VSS sensor, a malfunction is indicated (P0500). If there is insufficient output from the TSS sensor, a malfunction is indicated (P0715).

### **Transmission Outputs**

#### Shift Solenoids

The Shift Solenoid (SSA and SSB) output circuits are checked for opens and shorts by the PCM by monitoring the status of a feedback circuit from the output driver (P0750 SSA, P0755 SSB).

The shift solenoids are also checked functionally. Since the CD4E transmission does have a turbine speed sensor, the actual gear ratio can be computed any time the transmission is not shifting and the vehicle is not coasting. An actual gear ratio is computed in each gear and compared to the predicted gear ratio in order to determine the actual gear pattern obtained during an up-shift sequence. This information is then used to determine which shift solenoid is malfunctioning. For example, if SS1 is shorted to power or is hydraulically stuck in that position, the 1-2-3-4 commanded shifts will actually result in a 1-1-4-4 shift pattern. The unique shift pattern is used to determine which shift solenoid is malfunctioning. (P0751 SSA, P0756 SSB)

#### Torque Converter Clutch

The Torque Converter Clutch (TCC) output circuit is a duty-cycled output that is checked electrically for opens and shorts by the PCM by monitoring the status of a feedback circuit from the output driver (P0743).

The TCC solenoid is checked functionally by evaluating torque converter slip under steady state conditions when the torque converter is fully applied. If the slip exceeds the malfunction thresholds when the TCC is commanded on, a TCC malfunction is indicated (P1744). If there is no slip when the TCC is commanded off, a TCC malfunction is indicated (P1742)

#### Electronic Pressure Control

The EPC solenoid is a variable force solenoid that controls line pressure in the transmission. The EPC solenoid has a feedback circuit in the PCM that monitors EPC current. If the current indicates a short to ground (low pressure), engine torque may be reduced to prevent damage to the transmission. (P1747, PCA)

## 4R44E (RWD) Transmission

(has turbine speed sensor)

### Transmission Inputs

The Digital Transmission Range (DTR) sensor provides a single analog and three digital inputs to the PCM. The PCM decodes these inputs to determine the driver-selected gear position (Park, Rev, Neutral, OD, 2, 1). This input device is checked for opens and invalid input patterns. (P0708 P0705)

The Vehicle Speed Sensor (VSS) and Turbine Shaft Speed (TSS) sensor are digital inputs that are checked for rationality. If the engine rpm is above the torque converter stall speed and engine load is high, it can be inferred that the vehicle must be moving. If there is insufficient output from the VSS sensor, a malfunction is indicated (P0500). If there is insufficient output from the TSS sensor, a malfunction is indicated (P0715).

### Transmission Outputs

#### Shift Solenoids

The Shift Solenoid (SSA, SSB, and SSC) output circuits are checked for opens and shorts by the PCM by monitoring the status of a feedback circuit from the output driver (P0750 SSA, P0755 SSB, P0760 SSC).

The shift solenoids are also checked functionally. Since the 4R44E transmission does not have a turbine speed sensor, the actual gear ratio can be computed any time the transmission is not shifting and the vehicle is not coasting. An actual gear ratio is computed in each gear and compared to the predicted gear ratio in order to determine the actual gear pattern obtained during an upshift sequence. This information is then used to determine which shift solenoid is malfunctioning. For example, if SS1 is shorted to power or is hydraulically stuck in that position, the 1-2-3-4 commanded shifts will actually result in a 2-2-4-4 shift pattern. The unique shift pattern is used to determine which shift solenoid is malfunctioning. (P0751 SSA, P0756 SSB, P0761 SSC)

#### Torque Converter Clutch

The Torque Converter Clutch (TCC) output circuit is a duty-cycled output that is checked electrically for opens and shorts by the PCM by monitoring the status of a feedback circuit from the output driver (P0743).

The TCC solenoid is checked functionally by evaluating torque converter slip under steady state conditions when the torque converter is locked. If the slip exceeds the malfunction thresholds when the TCC is commanded on, a TCC DTC is stored (P1744). If there is no slip when the TCC is commanded off, a TCC DTC is stored (P1742).

#### Electronic Pressure Control Output

The EPC solenoid is a variable force solenoid that controls line pressure in the transmission. The EPC solenoid has a feedback circuit in the PCM that monitors EPC current. If the current indicates a short to ground (low pressure), engine torque may be reduced to prevent damage to the transmission. (P1747, PCA)

## 5R55E (RWD) Transmission

(has turbine speed sensor)

### Transmission Inputs

The Digital Transmission Range (DTR) sensor provides a single analog and three digital inputs to the PCM. The PCM decodes these inputs to determine the driver-selected gear position (Park, Rev, Neutral, OD, 2, 1). This input device is checked for opens and invalid input patterns. (P0708, P0705)

The Vehicle Speed Sensor (VSS), Turbine Shaft Speed (TSS) sensor and Output Shaft Speed (OSS) sensor, if equipped, are analog inputs that are checked for rationality. If the engine rpm is above the torque converter stall speed and engine load is high, it can be inferred that the vehicle must be moving. If there is insufficient output from the VSS sensor, a malfunction is indicated (P0500). If there is insufficient output from the TSS sensor, a malfunction is indicated (P0715). If there is insufficient output from the OSS sensor, a malfunction is indicated (P0720).

### Transmission Outputs

#### Shift Solenoids

The Shift Solenoid (SSA, SSB, SSC and SSD) output circuits are checked for opens and shorts by the PCM by monitoring the status of a feedback circuit from the output driver (P0750 SSA, P0755 SSB, P0760 SSC, P0765 SSD).

The shift solenoids are also checked functionally. Since the 5R55E transmission does have a turbine speed sensor, the actual gear ratio can be computed any time the transmission is not shifting. An actual gear ratio is computed in each gear and compared to the predicted gear ratio in order to determine the actual gear pattern obtained during an upshift sequence. This information is then used to determine which shift solenoid is malfunctioning. For example, if SS1 is shorted to power or is hydraulically stuck in that position, the 1-2-3-4-5 commanded shifts will actually result in a 2-2-4-4-5 shift pattern. The unique shift pattern is used to determine which shift solenoid is malfunctioning. (P0751 SSA, P0756 SSB, P0761 SSC, P0762 SSD)

Some vehicle applications will utilize an inductive signature circuit to monitor the shift solenoids functionally. The ISIG circuit monitors the current signature of the shift solenoid as the solenoid is commanded on. A solenoid that functions properly will show a characteristic decrease in current as the solenoid starts to move. If the solenoid is malfunctioning, the current will not change (P1714 SSA, P1715 SSB, P1716 SSC, P1717 SSD). The ISIG test is run in conjunction with the other transmission functional tests.

#### Torque Converter Clutch

The Torque Converter Clutch (TCC) output circuit is a duty-cycled output that is checked electrically for opens and shorts by the PCM by monitoring the status of a feedback circuit from the output driver (P0743).

The TCC solenoid is checked functionally by evaluating torque converter slip under steady state conditions when the torque converter is locked. If the slip exceeds the malfunction thresholds when the TCC is commanded on, a TCC DTC is stored (P1744). If there is no slip when the TCC is commanded off, a TCC DTC is stored (P1742).

Some vehicle applications will utilize an inductive signature circuit to monitor the torque converter clutch. The ISIG circuit monitors the current signature of the TCC solenoid as the solenoid is commanded on. A solenoid that functions properly will show a characteristic decrease in current as the solenoid starts to move. If the solenoid is malfunctioning, the current will not change (P1740). The ISIG test runs in conjunction with the other transmission functional tests.

## Electronic Pressure Control Output

The EPC solenoid is a variable force solenoid that controls line pressure in the transmission. The EPC solenoid has a feedback circuit in the PCM that monitors EPC current. If the current indicates a short to ground (low pressure), engine torque may be reduced to prevent damage to the transmission. (P1747, PCA)

## **4R100 (E4OD) (RWD) Transmission**

(no turbine speed sensor)

### **Transmission Inputs**

The Digital Transmission Range (DTR) sensor provides a single analog and three digital inputs to the PCM. The PCM decodes the inputs to determine the driver-selected gear position (Park, Rev, Neutral, OD, 2, 1). This input device is checked for opens and invalid input patterns. (P0708, P0705)

The Vehicle Speed Sensor (VSS) is an analog input that is checked for rationality. If the engine rpm is above the torque converter stall speed and engine load is high, it can be inferred that the vehicle must be moving. If there is insufficient output from the VSS sensor, a malfunction is indicated (P0500).

### **Transmission Outputs**

#### Shift Solenoids

The Shift Solenoid (SSA and SSB) output circuits are checked for opens and shorts by the PCM by monitoring the status of a feedback circuit from the output driver (P0750 SSA, P0755 SSB).

All vehicle applications will utilize an inductive signature circuit to monitor the shift solenoids functionally. The ISIG circuit monitors the current signature of the shift solenoid as the solenoid is commanded on. A solenoid that functions properly will show a characteristic decrease in current as the solenoid starts to move. If the solenoid is malfunctioning, the current will not change (P1714 SS1, P1715 SS2). The ISIG test runs in conjunction with the other transmission functional tests.

#### Torque Converter Clutch

The Torque Converter Clutch (TCC) output circuit is either an on/off or duty-cycled output that is checked electrically for opens and shorts internally in the PCM by monitoring the status of a feedback circuit from the output driver (P0743).

Vehicle applications with on/off output drivers will utilize an inductive signature circuit to monitor the torque converter clutch functionality. The ISIG circuit monitors the current signature of the TCC solenoid as the solenoid is commanded on. A solenoid that functions properly will show a characteristic decrease in current as the solenoid starts to move. If the solenoid is malfunctioning, the current will not change (P1740). The ISIG test runs in conjunction with the other transmission functional tests.

Vehicle applications that use duty-cycled output drivers utilize a rationality check for TCC operation. Actuation of the TCC on and off will result in a change of the calculated speed ratio under high engine load. If a speed ratio delta does not occur, a malfunction is indicated (P1744).

#### Electronic Pressure Control

The EPC solenoid is a variable force solenoid that controls line pressure in the transmission. The EPC solenoid has a feedback circuit in the PCM that monitors EPC current. If the current indicates a short to ground (low pressure), engine torque may be reduced to prevent damage to the transmission. (P1747, PCA)

## On Board Diagnostic Executive

The On-Board Diagnostic (OBD) Executive is a portion of the PCM strategy that manages the sequencing and execution of all diagnostic tests. It is the "traffic cop" of the diagnostic system. Each test/monitor can be viewed as an individual task, which may or may not be able to run concurrently with other tasks. The Diagnostic Executive enables/disables OBD monitors in order to accomplish the following:

- Sequence the OBD monitors such that when a test runs, each input that it relies upon has already been tested.
- Controls and co-ordinates the execution of the individual OBD system monitors: Catalyst, Misfire, EGR, O2, Fuel, AIR, EVAP and, Comprehensive Component Monitor (CCM).
- Stores freeze frame and "similar condition" data
- Manages storage and erasure of Diagnostic Trouble Codes as well as MIL illumination
- Controls and co-ordinates the execution of the On-Demand tests: Key On Engine Off (KOEO), Key On Engine Running (KOER), and the Output Test Mode (OTM).
- Performs transitions between various states of the diagnostic and powertrain control system to minimize the effects on vehicle operation.
- Interfaces with the diagnostic test tools to provide diagnostic information (I/M readiness, various J1979 test modes) and responds to special diagnostic requests (J1979 Mode 08 and 09).

The diagnostic also executive controls several overall, global OBD entry conditions.

- The Diagnostic Executive waits for 4 seconds after the PCM is powered before initiating any OBD monitoring.
- The Diagnostic Executive suspends OBD monitoring when battery voltage falls below 11.0 volts.

## Exponentially Weighted Moving Average

Exponentially Weighted Moving Averaging is a well-documented statistical data processing technique that is used to reduce the variability on an incoming stream of data. Use of EWMA does not affect the mean of the data, however, it does affect the distribution of the data. Use of EWMA serves to “filter out” data points that exhibit excessive and unusual variability and could otherwise erroneously light the MIL.

The simplified mathematical equation for EWMA implemented in software is as follows:

$$\text{New Average} = [\text{New data point} * \text{“filter constant”}] + [(1 - \text{“filter constant”}) * \text{Old Average}]$$

This equation produces an exponential response to a step-change in the input data. The “Filter Constant” determines the time constant of the response. A large filter constant (i.e. 0.90 ) means that 90% of the new data point is averaged in with 10% of the old average. This produces a very fast response to a step change. Conversely, a small filter constant (i.e. 0.10 ) means that only 10% of the new data point is averaged in with 90% of the old average. This produces a slower response to a step change.

When EWMA is applied to a monitor, the new data point is the result from the latest monitor evaluation. A new average is calculated each time the monitor is evaluated and stored in Keep Alive Memory (KAM). This normally occurs each driving cycle. The MIL is illuminated and a DTC is stored based on the New Average store in KAM.

In order to facilitate repair verification and DDV demonstration, 2 different filter constants are used. A “fast filter constant” is used after KAM is cleared/DTCs are erased and a “normal filter constant” is used for normal customer driving. The “fast filter” is used for 2 driving cycles after KAM is cleared/DTCs are erased, and then the “normal filter” is used. The “fast filter” allows for easy repair verification and monitor demonstration in 2 driving cycles, while the normal filter is used to allow up to 6 driving cycles, on average, to properly identify a malfunction and illuminate the MIL.

In order to relate filter constants to driving cycles for MIL illumination, filter constants must be converted to time constants. The mathematical relationship is described below:

$$\text{Time constant} = [ ( 1 / \text{filter constant} ) - 1 ] * \text{evaluation period}$$

The evaluation period is a driving cycle. The time constant is the time it takes to achieve 68% of a step-change to an input. Two time constants achieve 95% of a step change input.



## Catalyst Monitor EWMA

EWMA has been incorporated in the catalyst monitor. There are 3 calibrateable parameters that determine the MIL illumination characteristics.

- “Fast” filter constant, used for 2 driving cycles after DTCs are cleared or KAM is reset
- “Normal” filter constant, used for all subsequent, “normal” customer driving
- Number of driving cycles to use fast filter after KAM clear (normally set to 2 driving cycles)

Several examples for a typical calibration (4.6L Mark VIII ) are shown in the tables below. Specific calibration information can be obtained from the parameter listing provided for each strategy.

Monitor evaluation (“new data”)	EWMA Filter Calculation, “normal” filter constant set to 0.4 Malfunction threshold = .75	Weighted Average (“new average”)	Driving cycle number	Action/Comment
0.15	$.15 * (0.4) + .15 * (1 - 0.4)$	0.15		normal 100K system
1.0	$1.0 * (0.4) + .15 * (1 - 0.4)$	0.49	1	catastrophic failure
1.0	$1.0 * (0.4) + .49 * (1 - 0.4)$	0.69	2	
1.0	$1.0 * (0.4) + .69 * (1 - 0.4)$	0.82	3	exceeds threshold
1.0	$1.0 * (0.4) + .82 * (1 - 0.4)$	0.89	4	MIL on
0.15	$.15 * (0.4) + .15 * (1 - 0.4)$	0.15		normal 100K system
0.8	$0.8 * (0.4) + .15 * (1 - 0.4)$	0.41	1	1.5 * threshold failure
0.8	$0.8 * (0.4) + .41 * (1 - 0.4)$	0.57	2	
0.8	$0.8 * (0.4) + .57 * (1 - 0.4)$	0.66	3	
0.8	$0.8 * (0.4) + .66 * (1 - 0.4)$	0.72	4	
0.8	$0.8 * (0.4) + .72 * (1 - 0.4)$	0.75	5	exceeds threshold
0.8	$0.8 * (0.4) + .75 * (1 - 0.4)$	0.77	6	MIL on

## **I/M Readiness Code**

The readiness function is implemented based on the J1979 format. A battery disconnection or clearing codes using a scan tool results in the various I/M readiness bits being set to a “not-ready” condition. As each non-continuous monitor completes a full diagnostic check, the I/M readiness bit associated with that monitor is set to a “ready” condition. This may take one or two driving cycles based on whether malfunctions are detected or not. The readiness bits for comprehensive component monitoring, misfire and fuel system monitoring are considered complete once all the non-continuous monitors have been evaluated. Because the evaporative system monitor requires ambient conditions between 40 and 100 °F and BARO > 22.5 " Hg (< 8,000 ft.) to run, special logic can “bypass” the running the evap monitor for purposes of clearing the evap system I/M readiness bit due to the continued presence of these extreme conditions.

### **Evap bypass logic for 1997 vehicles:**

If the evaporative system monitor cannot complete because ambient temperature conditions were encountered outside the 40 to 100 °F and BARO range at speeds above 40 mph during a driving cycle in which all continuous and non-continuous monitors were evaluated, the evaporative system monitor is then considered complete due to the continued presence of extreme conditions. If the above conditions are repeated during a second driving cycle, the I/M readiness bit for the evaporative system is set to a “ready” condition. (Note: Some 1997 vehicles do not require catalyst monitor completion to bypass.)

### **Power Take Off Mode**

While PTO mode is engaged, the I/M readiness bits are set to a “not-ready” condition. When PTO mode is disengaged, the I/M readiness bits are restored to their previous states prior to PTO engagement. During PTO mode, only CCM circuit checks continue to be performed.

## **Serial Data Link MIL Illumination**

The instrument cluster on some vehicles uses the J1850 serial data link to receive and display various types of information from the PCM. For example, the engine coolant temperature information displayed on the instrument cluster comes from the same ECT sensor used by the PCM for all its internal calculations.

These same vehicles use the J1850 serial data link to illuminate the MIL rather than a circuit, hard-wired to the PCM. The PCM periodically sends the instrument cluster a message that tells it to turn on the MIL, turn off the MIL or blink the MIL. If the instrument cluster fails to receive a message within a 5-second timeout period, the instrument cluster itself illuminates the MIL. If communication is restored, the instrument cluster turns off the MIL after 5 seconds. Due to its limited capabilities, the instrument cluster does not generate or store Diagnostic Trouble Codes.