

REMOVAL AND INSTALLATION

Passenger Air Bag Module

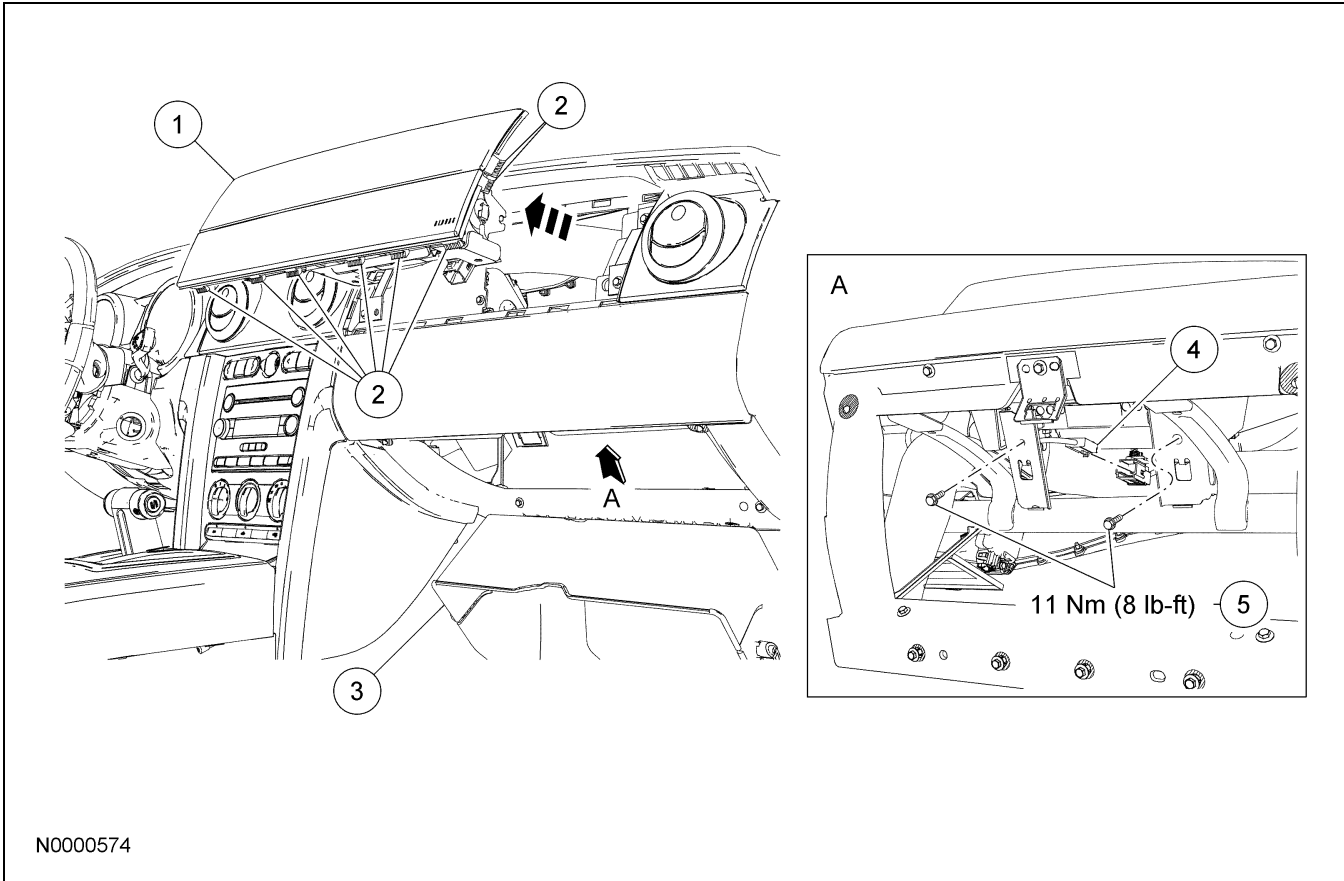

Item	Part Number	Description
1	044A74	Passenger air bag module
2	—	Passenger air bag module deployment door clips (part of 044A74)
3	—	Glove compartment door
4	—	Passenger air bag module electrical connector (part of 14401)
5	W505252	Passenger air bag module bolts (2 required)

Removal and Installation

⚠ WARNING: Always wear safety glasses when repairing an air bag supplemental restraint system (SRS) vehicle and when handling an air bag module. This will reduce the risk of injury in the event of an accidental deployment.

⚠ WARNING: Carry a live air bag module with the air bag and deployment door pointed away from your body. This will reduce the risk of injury in the event of an accidental deployment.

⚠ WARNING: Do not set a live air bag module down with the deployment door face down. This will reduce the risk of injury in the event of an accidental deployment.

REMOVAL AND INSTALLATION (Continued)

⚠ WARNING: After deployment, the air bag surface can contain deposits of sodium hydroxide, a product of the gas generant combustion that is irritating to the skin. Wash your hands with soap and water afterwards.

⚠ WARNING: Never probe the connectors on the air bag module. Doing so can result in air bag deployment, which can result in personal injury.

⚠ WARNING: Air bag modules with discolored or damaged deployment doors must be replaced, not repainted.

⚠ WARNING: To reduce the risk of personal injury, do not use any memory saver devices.

NOTE: The air bag warning lamp illuminates when the RCM fuse is removed and the ignition switch is ON. This is normal operation and does not indicate a supplemental restraint system (SRS) fault.

NOTE: The SRS must be fully operational and free of faults before releasing the vehicle to the customer.

NOTE: Repair is made by installing a new part only. If the new part does not correct the condition, install the original part and carry out the diagnostic procedure again.

1. Depower the system. For additional information, refer to Supplemental Restraint System (SRS) Depowering and Repowering in the General Procedures portion of this section.
2. Open and lower glove compartment door.
3. Disconnect the passenger air bag module electrical connector.
4. Remove the 2 air bag module bolts.
 - To install, tighten to 11 Nm (8 lb-ft)
5. **⚠ CAUTION:** Do not handle the passenger air bag module by grabbing the edges of the deployment door.

Through the glove box opening, release the deployment door clips (6 upper, 6 lower and 2 on each side) from the instrument panel (I/P) and then remove the passenger air bag module out of the I/P.
6. **NOTE:** During air bag module installation, make sure all the deployment door clips are fully seated into the I/P.

To install, reverse the removal procedure.
7. Repower the system. For additional information, refer to Supplemental Restraint System (SRS) Depowering and Repowering in the General Procedures portion of this section.