

REMOVAL AND INSTALLATION

Console — Floor

NOTE: Floor console with automatic transmission shown, floor console with manual transmission similar.

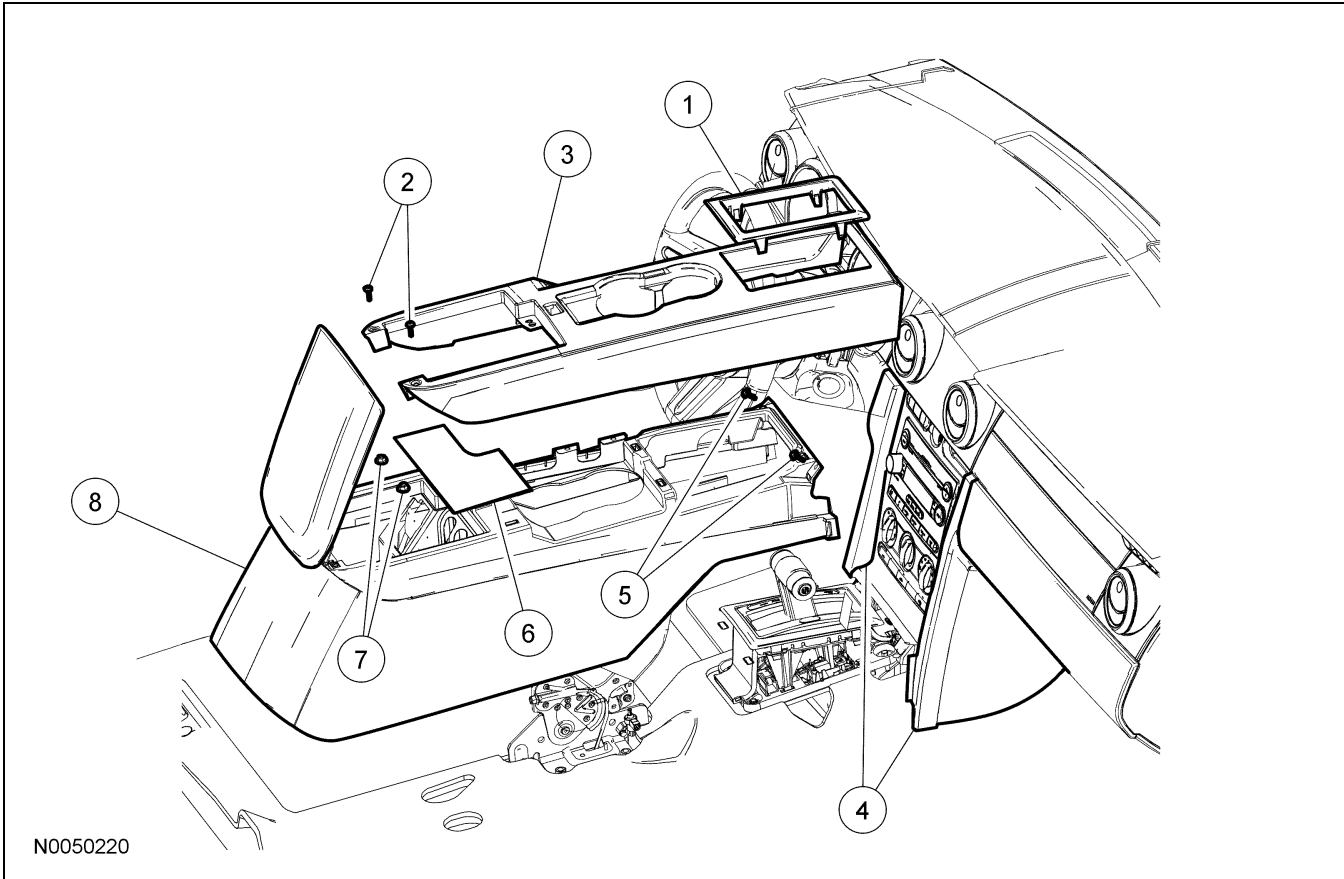

Item	Part Number	Description
1	7E391	Selector lever bezel
2	W705314	Floor console finish panel screws (2 required)
3	044D90	Floor console finish panel
4	04608 RH/ 04609 LH	Instrument panel finish panels
5	W707628	Floor console screws (2 required)
6	13586	Storage compartment mat
7	W711098	Floor console nuts (2 required)
8	045A36	Floor console

Removal and Installation

All vehicles

1. Apply the parking brake.

Vehicles with manual transmission

2. Place the gearshift lever in the NEUTRAL position.
3. Unscrew the gearshift lever knob.

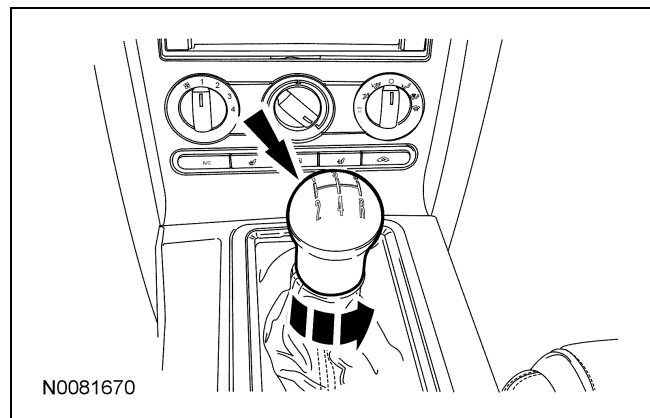

REMOVAL AND INSTALLATION (Continued)

4. Remove the gearshift lever knob and boot.
 - With a non-marring tool, lift the gearshift lever boot retainer upward.

Vehicles with automatic transmission

5. Place the selector lever in the NEUTRAL position.
6. Remove the selector lever bezel.
 - With a non-marring tool, lift the selector lever bezel upward.

All vehicles

7. Open the storage compartment door.
8. Remove the 2 floor console finish panel screws.

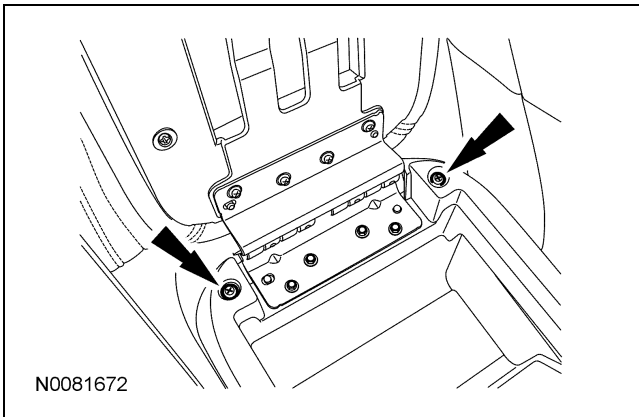

9. Remove the floor console finish panel.
 - Lift the floor console finish panel upward to release the retaining clips.
 - Disconnect the electrical connector(s).
10. Disconnect the power point and audio jack electrical connectors.
11. Remove the LH and RH instrument panel finish panels.
 - Pull outward on the instrument panel finish panels to release the retaining clips.
12. Remove the 2 floor console screws.
13. Remove the storage compartment mat.
14. Remove the 2 floor console nuts.

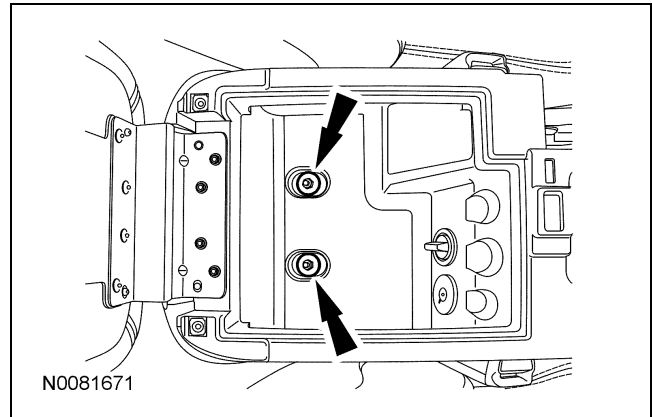

15. Remove the floor console.
16. To install, reverse the removal procedure.