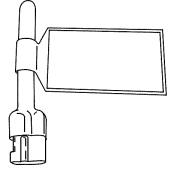
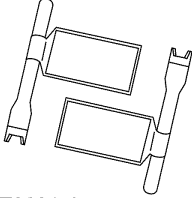
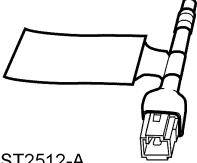
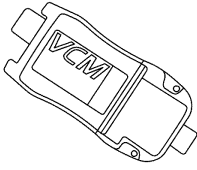

## GENERAL PROCEDURES

### Supplemental Restraint System (SRS) Deactivation and Reactivation

#### Special Tool(s)

 <p>ST2507-A</p>	<p>Diagnostic Tool, Restraint System (2 required) 418-133</p>
 <p>ST2621-A</p>	<p>Diagnostic Tool, Restraint System (2 required) 418-F395</p>
 <p>ST2512-A</p>	<p>Diagnostic Tool, Restraint System 418-F403</p>
 <p>ST2834-A</p>	<p>Vehicle Communication Module (VCM) and Integrated Diagnostic System (IDS) software with appropriate hardware, or equivalent scan tool</p>

#### Deactivation

**⚠ WARNING:** Always wear eye protection when servicing a vehicle. Failure to follow this instruction may result in serious personal injury.

**⚠ WARNING:** Never probe the electrical connectors on air bag, safety canopy or side air curtain modules. Failure to follow this instruction may result in the accidental deployment of these modules, which increases the risk of serious personal injury or death.

**⚠ WARNING:** Remove restraint system diagnostic tools from the vehicle prior to road testing. If tools are not removed, the supplemental restraint system (SRS) device may not deploy in a crash. Failure to follow this instruction may result in serious personal injury or death in a crash and possibly violate vehicle safety standards.

**⚠ WARNING:** To reduce the risk of accidental deployment, do not use any memory saver devices. Failure to follow this instruction may result in serious personal injury or death.

**NOTE:** The air bag warning indicator illuminates when the correct restraints control module (RCM) fuse is removed and the ignition switch is ON.

**NOTE:** The supplemental restraint system (SRS) must be fully operational and free of faults before releasing the vehicle to the customer.

1. Turn all vehicle accessories OFF.
2. Turn the ignition switch to OFF.
3. At the smart junction box (SJB), located in the RH lower kick panel, remove the cover and the RCM fuse 17 (10A) from the SJB. For additional information, refer to the Wiring Diagram Manual.
4. Turn the ignition ON and visually monitor the air bag warning indicator for at least 30 seconds. The air bag warning indicator will remain lit continuously (no flashing) if the correct RCM fuse has been removed. If the air bag warning indicator does not remain lit continuously, remove the correct RCM fuse before proceeding.
5. Turn the ignition OFF.

**GENERAL PROCEDURES (Continued)**

6.  **WARNING:** Always deplete the backup power supply before repairing or installing any new front or side air bag supplemental restraint system (SRS) component and before servicing, removing, installing, adjusting or striking components near the front or side impact sensors or the restraints control module (RCM). Nearby components include doors, instrument panel, console, door latches, strikers, seats and hood latches.

Refer to the Description and Operation portion of Section 501-20B for location of the RCM and impact sensor(s).

To deplete the backup power supply energy, disconnect the battery ground cable and wait at least 1 minute. Be sure to disconnect auxiliary batteries and power supplies (if equipped).

Failure to follow these instructions may result in serious personal injury or death in the event of an accidental deployment.

Disconnect the battery ground cable and wait at least one minute. For additional information, refer to Section 414-01.

7. Remove the 2 driver air bag module bolt caps (1 shown) from the steering wheel.

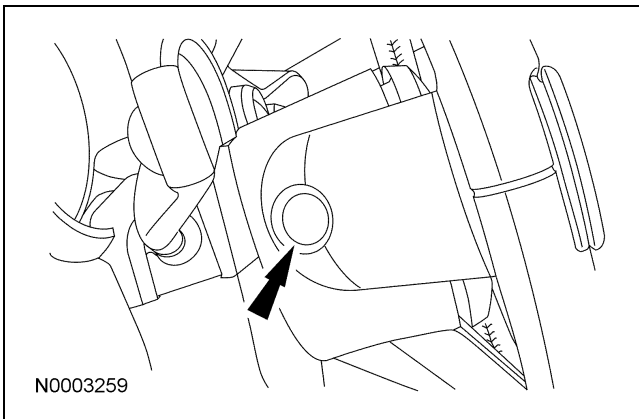

8. Remove the 2 driver air bag module bolts (1 shown).

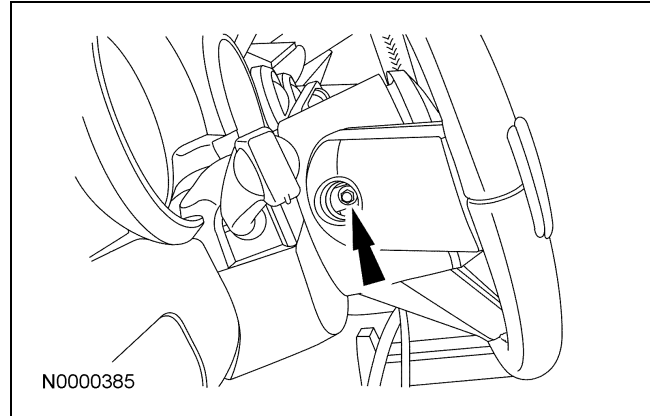

9. Disconnect the 2 electrical connectors and remove the driver air bag module.

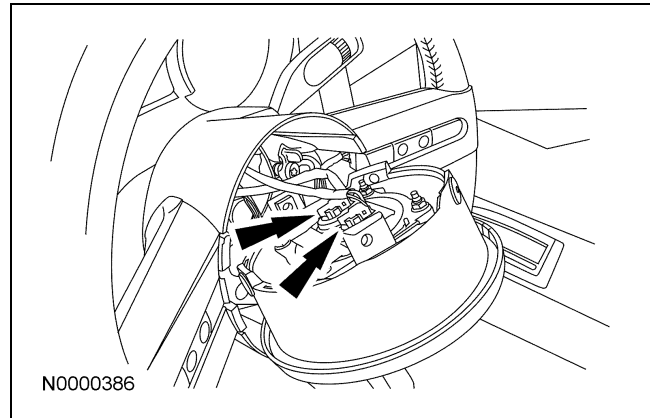

10. Attach the Restraint System Diagnostic Tool to the clockspring electrical connectors.

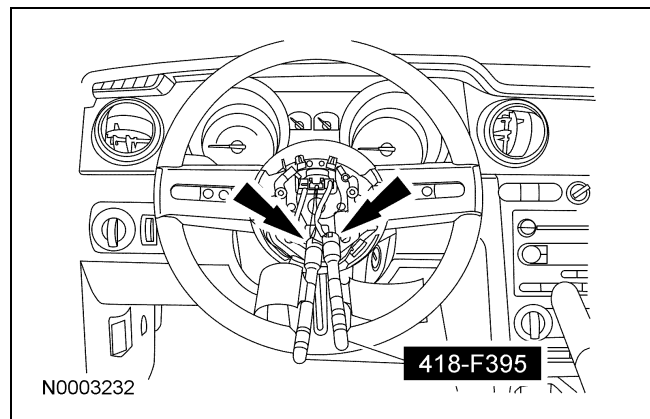

11. Fully lower the glove compartment door.

**GENERAL PROCEDURES (Continued)**

12. Disconnect the passenger air bag module electrical connector.

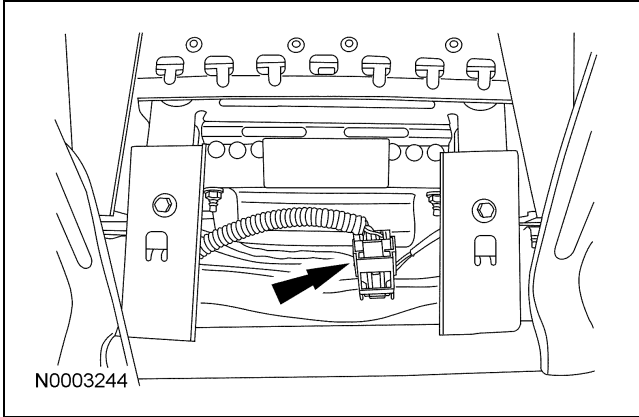

13. Attach the Restraint System Diagnostic Tool to the vehicle harness side of the passenger air bag module electrical connector.

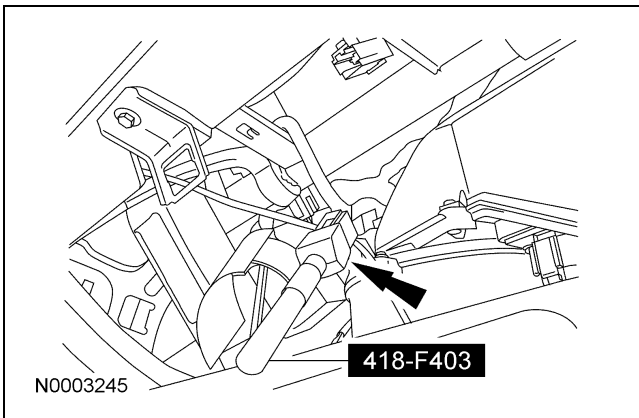

14. Release the red locking tab and disconnect the passenger side air bag module electrical connector.

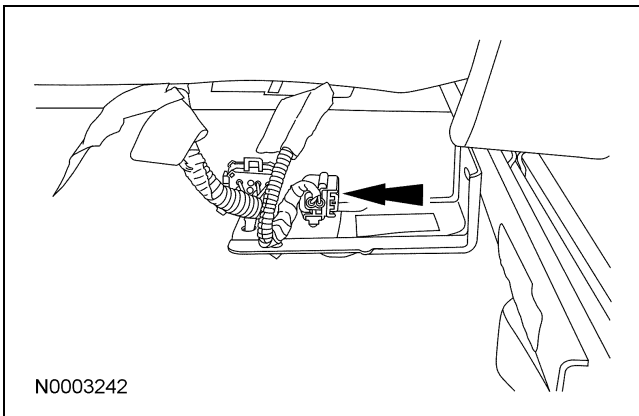

15. Attach the Restraint System Diagnostic Tool to the vehicle harness side of the passenger side air bag module electrical connector.

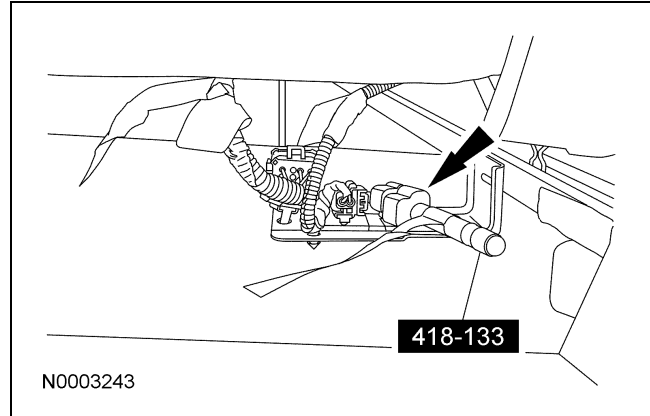

16. Release the red locking tab and disconnect the driver side air bag module electrical connector.

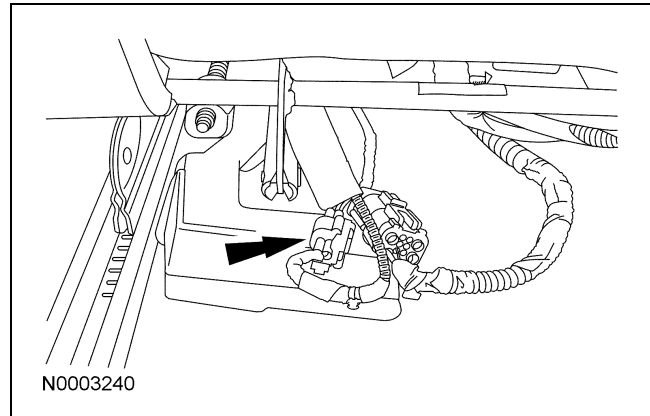

17. Attach the Restraint System Diagnostic Tool to the vehicle harness side of the driver side air bag module electrical connector.

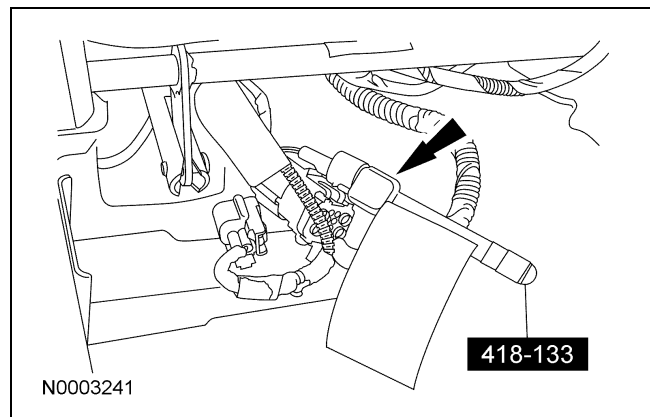

18. Install RCM fuse 17 (10A) to the SJB.

19. Connect the battery ground cable. For additional information, refer to Section 414-01.

**GENERAL PROCEDURES (Continued)****Reactivation**

1. Remove RCM fuse 17 (10A) from the SJB.
2. Disconnect the battery ground cable and wait at least one minute.
3. Remove the Restraint System Diagnostic Tool from the vehicle harness side of the driver side air bag module electrical connector.

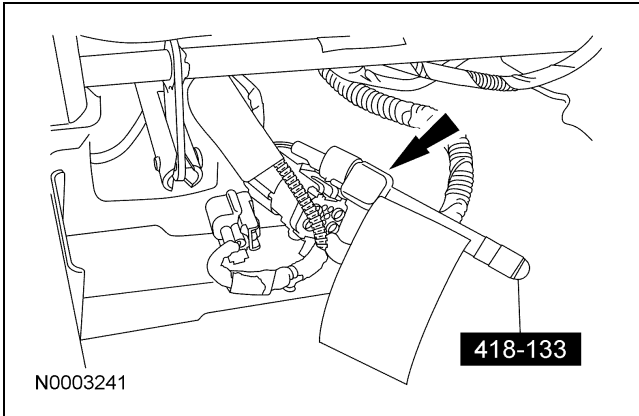

4. Connect the driver side air bag module electrical connector and reset the red locking tab.

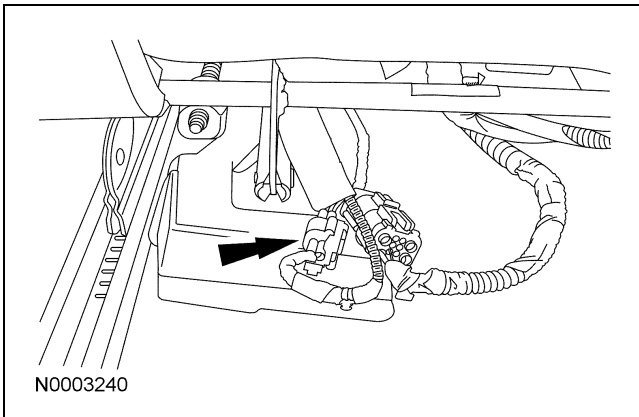

5. Remove the Restraint System Diagnostic Tool from the vehicle harness side of the passenger side air bag module electrical connector.

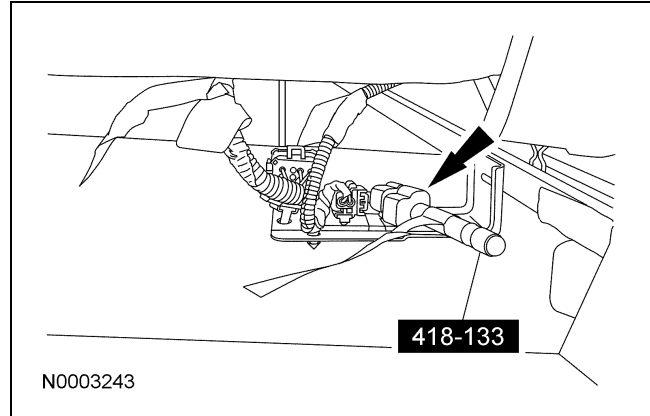

6. Connect the passenger side air bag module electrical connector and reset the red locking tab.

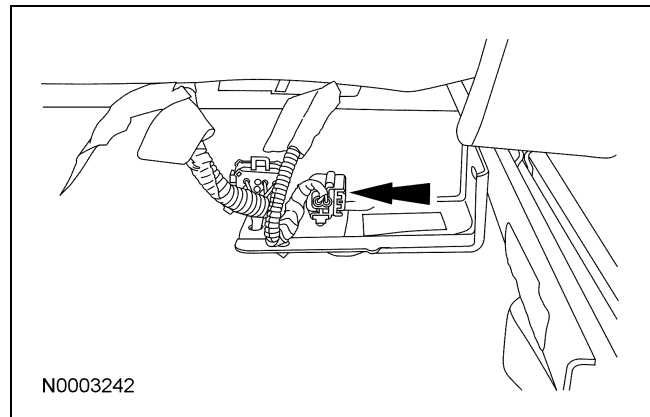

7. Remove the Restraint System Diagnostic Tool from the vehicle harness side of the passenger side air bag module electrical connector.

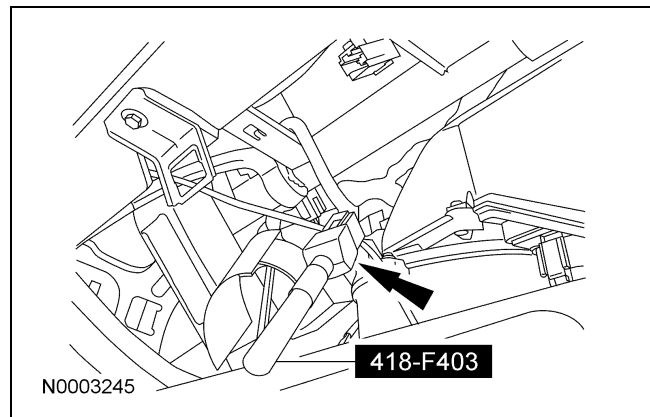

**GENERAL PROCEDURES (Continued)**

8. Connect the passenger air bag module electrical connector.

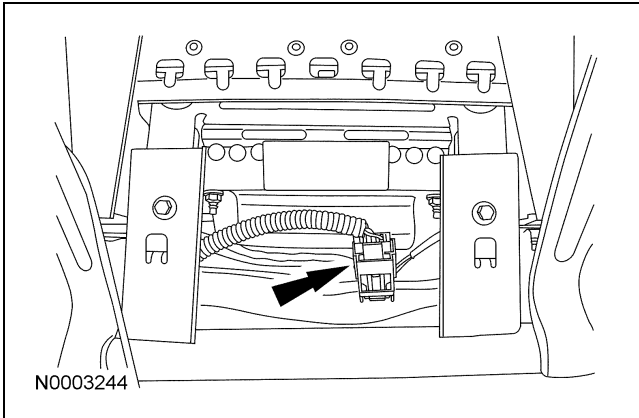

9. Close the glove compartment door.

10. Remove the Restraint System Diagnostic Tool from the clockspring electrical connectors.

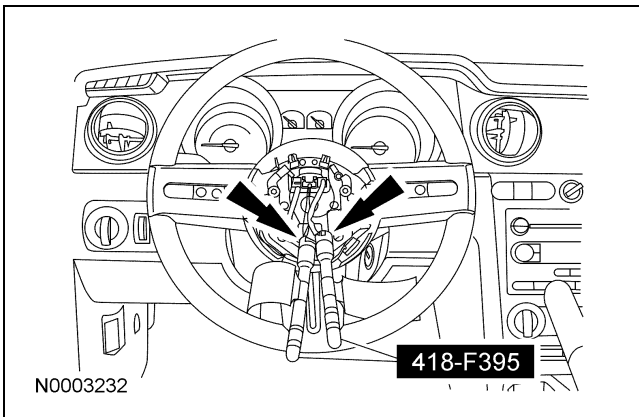

11. **NOTICE:** The driver air bag module electrical connectors are unique and cannot be reversed when connected to the driver air bag module. Match the electrical connector key to the keyway in the driver air bag module. Do not force the electrical connectors into the driver air bag module. Damage to the connector or component may occur.

Connect the 2 electrical connectors and position the driver air bag module.

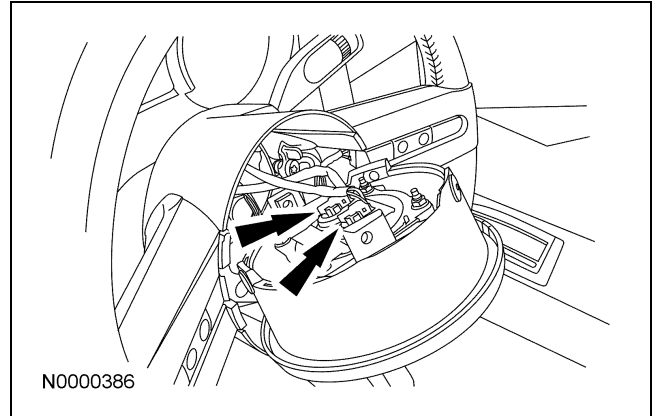

12. Install the 2 driver air bag module bolts (1 shown).

- Tighten to 7 Nm (62 lb-in).

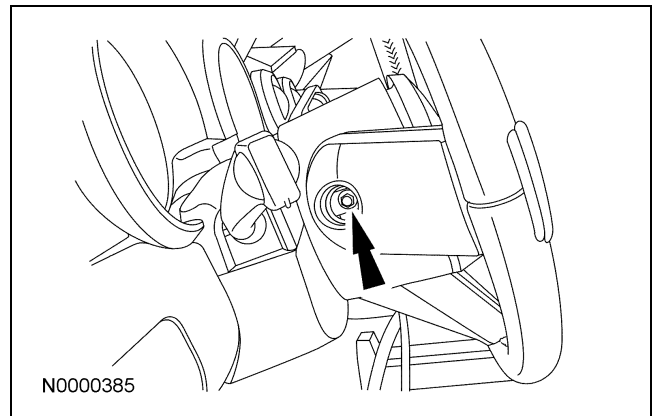

13. Install the 2 driver air bag module bolt caps (1 shown) in the steering wheel.

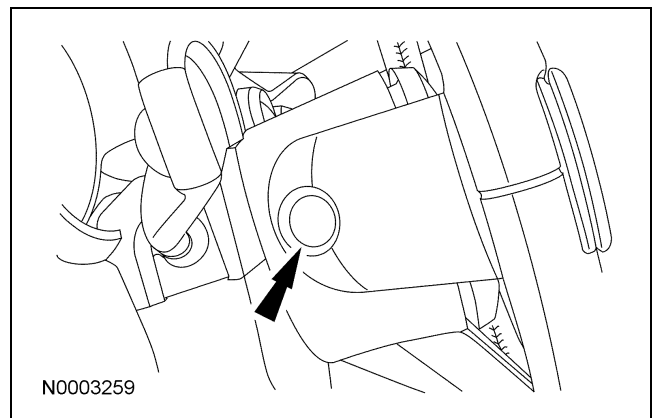

**GENERAL PROCEDURES (Continued)**

14.  **WARNING: Remove restraint system diagnostic tools from the vehicle prior to road testing. If tools are not removed, the supplemental restraint system (SRS) device may not deploy in a crash. Failure to follow this instruction may result in serious personal injury or death in a crash and possibly violate vehicle safety standards.**

Make sure all restraint system diagnostic tool(s) that may have been installed during the repair have been removed from the vehicle and all SRS components are connected.

15. Turn the ignition switch from OFF to ON.
16. Install RCM fuse 17 (10A) to the SJB and close the cover.
17.  **WARNING: Make sure no one is in the vehicle and there is nothing blocking or placed in front of any air bag module when the battery is connected. Failure to follow these instructions may result in serious personal injury in the event of an accidental deployment.**

Connect the battery ground cable.

18. Prove out the SRS as follows:

Turn the ignition key from ON to OFF. Wait 10 seconds, then turn the key back to ON and visually monitor the air bag warning indicator with the air bag modules installed. The air bag warning indicator will light continuously for approximately 6 seconds and then turn off. If an air bag SRS fault is present, the air bag warning indicator will:

- fail to light.
- remain lit continuously.
- flash at a 5Hz rate (RCM not configured).

The air bag warning indicator might not light until approximately 30 seconds after the ignition switch has been turned from the OFF to the ON position. This is the time required for the RCM to complete the testing of the SRS. If the air bag warning indicator is inoperative and a SRS fault exists, a chime will sound in a pattern of 5 sets of 5 beeps. If this occurs, the air bag warning indicator and any SRS fault discovered must be diagnosed and repaired.

Clear all continuous DTCs from the RCM using a scan tool.