

REMOVAL AND INSTALLATION

Seat Backrest Cover — Front

Removal and Installation

⚠ WARNING: Always wear safety glasses when repairing an air bag supplemental restraint system (SRS) vehicle and when handling an airbag module. This will reduce the risk of injury in the event of an accidental deployment.

⚠ WARNING: Front seat back trim covers installed on seats equipped with side air bags cannot be repaired; they are to be replaced (cleaning is permissible).

⚠ WARNING: To reduce the risk of personal injury, do not use any memory saver devices.

NOTE: If a seat equipped with a supplemental restraint system (SRS) component is being serviced, the supplemental restraint system (SRS) must be depowered.

NOTE: The air bag warning lamp illuminates when the restraints control module (RCM) fuse is removed and the ignition switch is ON. This is normal operation and does not indicate a supplemental restraint system (SRS) fault.

NOTE: The SRS must be fully operational and free of faults before releasing the vehicle to the customer.

1. Position the seat to gain access to the seat track-to-floor nuts and bolts.
2. Depower the SRS. For additional information, refer to Supplemental Restraint System (SRS) Depowering and Repowering in the General Procedures portion of Section 501-20B.
3. Remove the front seat. For additional information, refer to Seat — Front in this section.
4. Remove the front seat backrest. For additional information, refer to Seat Backrest — Front in this section.
5. Remove the head restraint.
 - 1 Position the head restraint as high as it will go.
 - 2 Using an appropriate tool, push through the hole on the inboard side of the head restraint guide and release the head restraint.
 - Hold the head restraint up so it does not engage back into the head restraint guide.
 - 3 Release the head restraint guide on the other side and remove the head restraint.

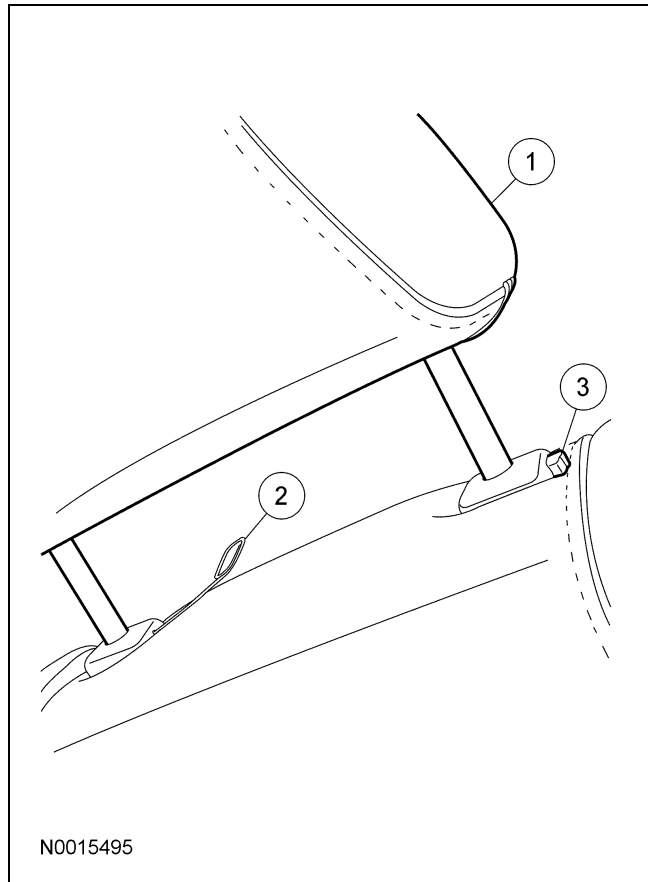

REMOVAL AND INSTALLATION (Continued)

6. Remove the plastic rivets attaching the backrest trim cover to the inboard and outboard recliners.

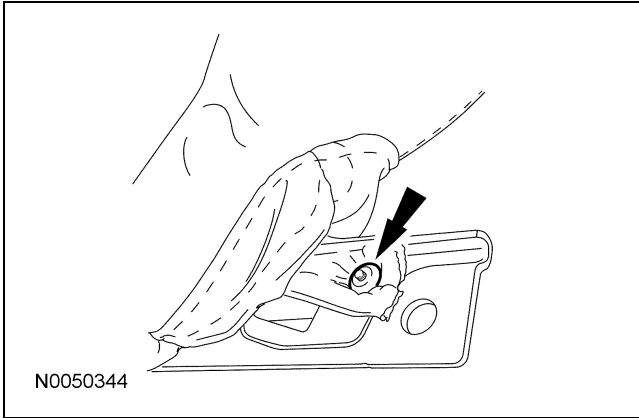

9. Release the inner J-strip at the bottom of the backrest trim cover and remove the harness wires from the backrest cover.

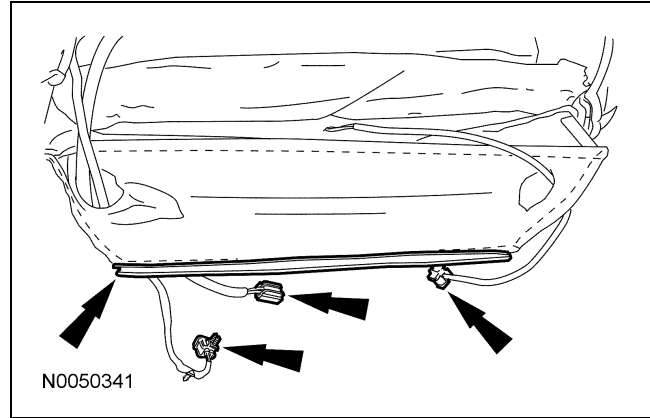

7. Remove the backrest recliner release bezel screw. Slide down, pull and remove the backrest recliner release bezel and backrest recliner release handle.

8. Release the outer J-strip at the bottom of the backrest trim cover.

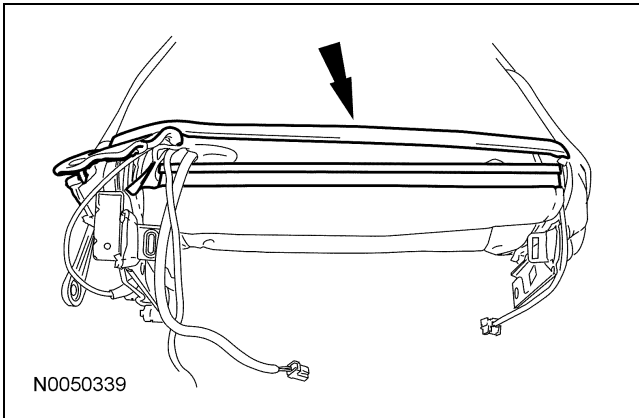

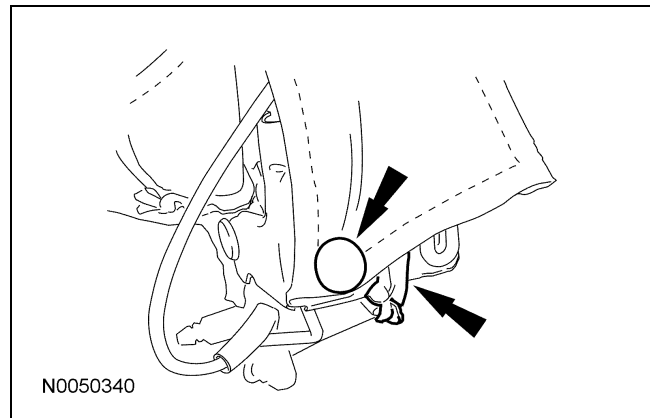

10. Release the pin-type retainer and backrest trim from the backrest frame.



REMOVAL AND INSTALLATION (Continued)

11.  **WARNING:** Front seat back trim covers installed on seats equipped with side air bags cannot be repaired, they are to be installed new. Cleaning is permissible.

 **WARNING:** To correctly retain the backrest trim cover and allow correct deployment of the seat side air bag module, make sure to install 2 hog rings to attach the backrest trim cover wire to the listing wire in each foam pad window. Failure to follow this instruction may result in personal injury in the event of a seat side air bag module deployment.

 **CAUTION:** Use care when separating the seat cushion trim cover from the hook-and-loop strip. The hook-and-loop strip can be torn from the seat cushion foam.

Invert the backrest trim cover up and remove the first row of hog rings.

- 1 Place a hand between the backrest trim cover and backrest foam pad and carefully separate the hook-and-loop strips.
- 2 Remove the 2 hog rings per window.

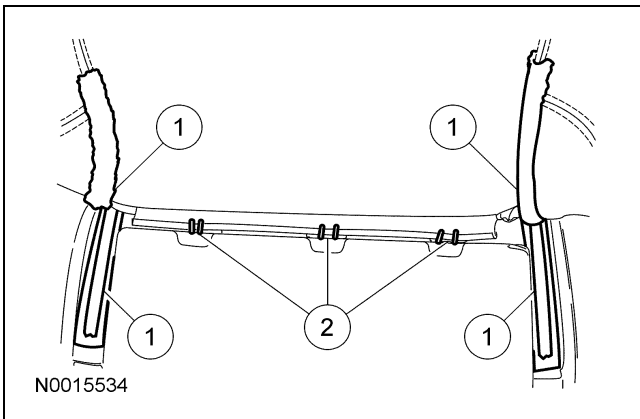

12.  **WARNING:** To correctly retain the backrest trim cover and allow correct deployment of the seat side air bag module, make sure to install 2 hog rings to attach the backrest trim cover wire to the listing wire in each foam pad window. Failure to follow this instruction may result in personal injury in the event of a seat side air bag module deployment.

Invert the backrest trim cover up and remove the second row of hog rings.

- 1 Place a hand between the backrest trim cover and backrest foam pad and carefully separate the hook-and-loop strips.
- 2 Remove the 2 hog rings per window.

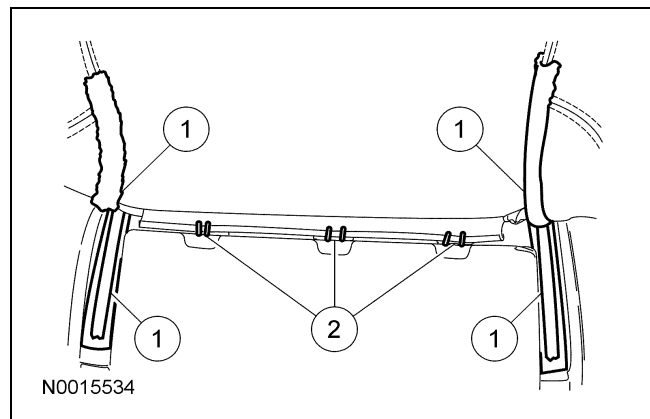

13. Invert the backrest trim cover to the top of the backrest.
14. **NOTE:** The head restraint guides are not interchangeable.
Release and remove the 2 head restraint guides.
15. Remove the backrest trim cover.
16. **NOTE:** A backrest trim cover for a seat with a side air bag module is different than a backrest trim cover for a seat without a side air bag module. Make sure the correct backrest trim cover is being installed.
To install, reverse the removal procedure.
17. Install the front seat backrest. For additional information, refer to Seat Backrest — Front in this section.
18. Install the seat. For additional information, refer to Seat — Front in this section.

REMOVAL AND INSTALLATION (Continued)

19. Repower the SRS. For additional information, refer to Supplemental Restraint System (SRS) Depowering and Repowering in the General Procedures portion of Section 501-20B.
-