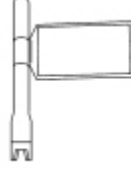

## Seats

Refer to Wiring Diagrams Cell 120, Power Seats for schematic and connector information.

Refer to Wiring Diagrams Cell 122, Power Lumbar Seats for schematic and connector information.

### Special Tool(s)

 ST1137-A	73 III Automotive Meter 105-R0057
 ST2502-A	Diagnostic Tool, Restraint System (2 required) <a href="#">418-133</a>

### Restraint System Diagnostic Tool Warning

**⚠️ WARNING:** This tool is for restraint system service only. Remove from vehicle prior to road use. Failure to remove could result in injury and possible violation of vehicle safety standards.

### Principles of Operation — Power Seats Without Memory

The 6-way power seat feature moves the seat in 6 possible directions: the base of the seat can be moved forward or backward and the front and back of the seat cushion can be moved up and down independently. The power seat feature operates independent of the position of the ignition.

The power seat motors are hardwired to the seat control switch. The circuits are normally at ground through the seat control switch. An individual circuit is switched to power when a specific adjustment position is selected.

### Inspection and Verification

1. Verify the customer concern by operating the system.
2. Visually inspect for obvious signs of mechanical or electrical damage.

### Visual Inspection Chart

Mechanical	Electrical
<ul style="list-style-type: none"> <li>• Front seat track</li> <li>• Seat at limit(s) of travel</li> <li>• Seat tracks obstructed or damaged</li> <li>• Power lumbar assembly damaged</li> </ul>	<ul style="list-style-type: none"> <li>• Battery junction box (BJB) F1.12 (30A)</li> <li>• Loose, corroded or damaged connectors</li> <li>• Seat control switch</li> <li>• Lumbar seat control switch</li> <li>• Lumbar motor.</li> </ul>

3. If an obvious cause for an observed or reported concern is found, correct the cause (if possible) before proceeding to the next step.
4. If the concern is not visually evident, verify the symptom. GO to [Symptom Chart](#).

### Symptom Chart

Refer to the Wiring Diagram manual for the connector numbers cited in the pinpoint tests.

**SYMPTOM CHART**

Condition	Possible Sources	Action
• The power seat is inoperative	<ul style="list-style-type: none"> <li>• Fuse.</li> <li>• Circuitry.</li> <li>• Seat control switch.</li> </ul>	• <a href="#">GO to Pinpoint Test A.</a>
• The power seat moves but is noisy	<ul style="list-style-type: none"> <li>• Seat track alignment.</li> <li>• Seat track.</li> </ul>	• <a href="#">GO to Pinpoint Test B.</a>
• The power seat moves but is loose	<ul style="list-style-type: none"> <li>• Fastening hardware.</li> <li>• Seat track.</li> </ul>	• <a href="#">GO to Pinpoint Test C.</a>
• The power seat does not make full travel	<ul style="list-style-type: none"> <li>• Seat track obstructed.</li> <li>• Seat track.</li> </ul>	• <a href="#">GO to Pinpoint Test D.</a>
• The power seat does not move horizontally/vertically	<ul style="list-style-type: none"> <li>• Circuitry.</li> <li>• Seat control switch.</li> <li>• Seat track.</li> </ul>	• <a href="#">GO to Pinpoint Test E.</a>
• The power lumbar is inoperative	<ul style="list-style-type: none"> <li>• Fuse.</li> <li>• Circuitry.</li> <li>• Lumbar control switch.</li> <li>• Lumbar motor</li> </ul>	• <a href="#">GO to Pinpoint Test F.</a>

**Connector Circuit Reference**

**Driver Seat Control Switch C360**

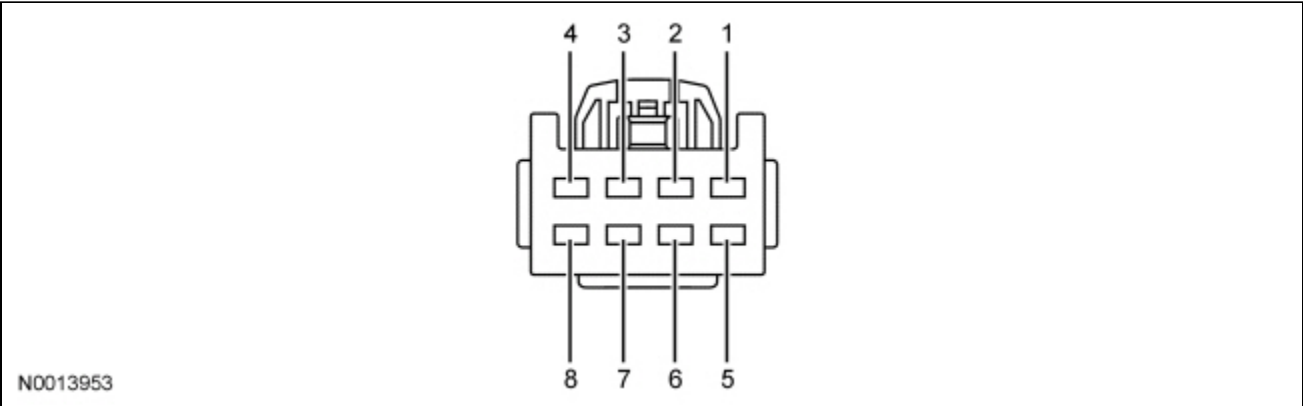

Pin Number(s)	Circuit Designation/Description	Normal Condition/Measurement
1	CKT 979 (RD/LB) Front UP	Less than 5 ohms to seat track.
2	CKT 1205 (BK) Ground	Less than 5 ohms to ground.
3	CKT 980 (YE/WH) FORWARD	Less than 5 ohms to seat track.
4	CKT 566 (DG) Battery voltage from power distribution box	Greater than 10 volts at all times.
5	CKT 983 (RD/LG) Rear UP	Less than 5 ohms to seat track.
6	CKT 981 (RD/WH) REARWARD	Less than 5 ohms to seat track.
7	CKT 982 (YE/LG) Rear DOWN	Less than 5 ohms to seat track.
8	CKT 990 (YE/LB) Front DOWN	Less than 5 ohms to seat track.

**Driver Power Seat Motor C353**

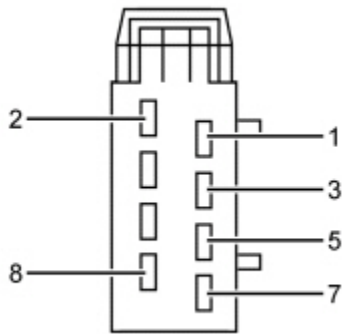

N0013952

Pin Number(s)	Circuit Designation/Description	Normal Condition/Measurement
1	CKT 979 (RD/LB) Front UP	Less than 5 ohms to seat control switch. Greater than 10 volts in front UP, less than 5 ohms to ground in front DOWN and when seat control switch is not pressed.
2	CKT 982 (YE/LG) Rear DOWN	Less than 5 ohms to seat control switch. Greater than 10 volts in rear DOWN, less than 5 ohms to ground in rear UP and when seat control switch is not pressed.
3	CKT 981 (RD/WH) FORWARD	Less than 5 ohms to seat control switch. Greater than 10 volts in FORWARD, less than 5 ohms to ground in REARWARD and when seat control switch is not pressed.
5	CKT 980 (YE/WH) REARWARD	Less than 5 ohms to seat control switch. Greater than 10 volts in REARWARD, less than 5 ohms to ground in FORWARD and when seat control switch is not pressed.
7	CKT 990 (YE/LB) Front DOWN	Less than 5 ohms to seat control switch. Greater than 10 volts in front DOWN, less than 5 ohms to ground in front UP and when seat control switch is not pressed.
8	CKT 983 (RD/LG) Rear UP	Less than 5 ohms to seat control switch. Greater than 10 volts in rear UP, less than 5 ohms to ground in rear DOWN and when seat control switch is not pressed.

**Lumbar Control Switch C361**

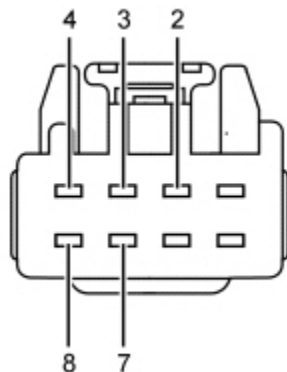

N0013954

Pin Number(s)	Circuit Designation/Description	Normal Condition/Measurement
1	—	—
2	CKT 1205 (BK) Ground	Less than 5 ohms to ground.
3	CKT 1097 (BN) Lumbar OUT	Less than 5 ohms to lumbar motor.
4	CKT 566 (DG) Battery voltage from the battery junction box (BJB).	Greater than 10 volts at all times.
5	—	—

Pin Number(s)	Circuit Designation/Description	Normal Condition/Measurement
6	—	—
7	CKT 1094 (PK) Lumbar IN	Less than 5 ohms to lumbar motor.
8	CKT 1205 (BK) Ground	Less than 5 ohms to ground.

### Power Lumbar Motor C366

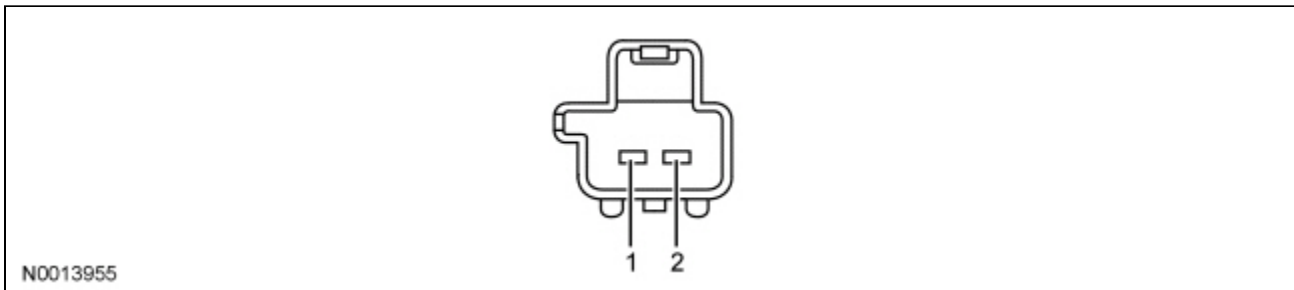

Pin Number(s)	Circuit Designation/Description	Normal Condition/Measurement
1	CKT 1097 (BN) Lumbar OUT	Less than 5 ohms to the lumbar control switch. Greater than 10 volts when the lumbar control switch is in lumbar OUT, less than 5 ohms to ground when switch is in lumbar IN and when the lumbar control switch is not pressed.
2	CKT 1094 (PK) Lumbar IN	Less than 5 ohms to the lumbar control switch. Greater than 10 volts when the lumbar control switch is in lumbar IN, less than 5 ohms to ground when switch is in lumbar OUT and when the lumbar control switch is not pressed.

### Pinpoint Tests

Refer to Inspection and Verification and the Symptom Chart for direction to the appropriate Pinpoint Test.

#### Pinpoint Test A: The Power Seat Is Inoperative

##### Normal Operation

The seat control switch is powered by battery voltage on circuit 566 (DG) and is supplied ground on circuit 1205 (BK).

##### Possible Causes

An inoperative power seat can be caused by:

- a fuse.
- wiring, terminals or connectors.
- a faulty power seat switch.

#### PINPOINT TEST A : THE POWER SEAT IS INOPERATIVE

##### A1 CHECK FUSE F1.12 (30A)

**⚠ WARNING:** The restraint system diagnostic tool is for restraint system service only. Remove from vehicle prior to road use. Failure to remove could result in injury and possible violation of vehicle safety standards.

**NOTE:** If a seat equipped with a supplemental restraint system (SRS) component is being serviced, **the SRS must be depowered.** Refer to [Section 501-20B](#).

**NOTE:** The air bag warning lamp illuminates when the RCM fuse is removed and the ignition switch is ON. This is normal operation and does not indicate a supplemental restraint system (SRS) fault.

**NOTE:** The SRS must be fully operational and free of faults before releasing the vehicle to the customer.

- Ignition OFF.
- Depower the SRS. Refer to Supplemental Restraint System (SRS) Depowering and Repowering in the General Procedures portion of [Section 501-20B](#).

• **⚠ WARNING: Be sure that nobody is in the vehicle and that there is nothing blocking or set in front of any air bag module when the battery ground cable is connected.**

For vehicles equipped with seat side air bags, carry out the following:

- Depower the SRS. Refer to Supplemental Restraint System (SRS) Depowering and Repowering in the General Procedures portion of [Section 501-20B](#).

Disconnect driver seat side air bag C367.

Connect restraint system diagnostic tool 418-133 to driver seat side air bag C367.

Connect the battery ground cable.

- Check fuse: Fuse F1.12 (30A).

**Is the fuse OK?**

<b>Yes</b>	GO to <a href="#">A2</a> .
<b>No</b>	INSTALL a new fuse. TEST the system for normal operation. If the fuse fails again, CHECK for a short to ground. REPAIR as necessary. For vehicles equipped with seat side air bags, DISCONNECT the battery ground cable. DISCONNECT the restraint system diagnostic tool from driver seat side air bag module C367. CONNECT driver seat side air bag module C367. REPOWER the SRS. REFER to <a href="#">Section 501-20B</a> .

## **A2 CHECK THE VOLTAGE TO SEAT CONTROL SWITCH CIRCUIT 566 (DG)**

- Disconnect: Driver Seat Control Switch C360.
- Measure the voltage between driver seat control switch C360 pin 4, circuit 566 (DG), harness side and ground.

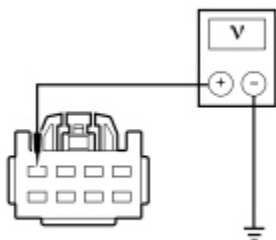

N0013956

**Is the voltage greater than 10 volts?**

<b>Yes</b>	GO to <a href="#">A3</a> .
<b>No</b>	REPAIR the circuit. TEST the system for normal operation. For vehicles equipped with seat side air bags, DISCONNECT the battery ground cable. DISCONNECT the restraint system diagnostic tool from driver seat side air bag module C367. CONNECT driver seat side air bag module C367. REPOWER the SRS. REFER to <a href="#">Section 501-20B</a> .

## **A3 CHECK SEAT CONTROL SWITCH CIRCUIT 1205 (BK) FOR AN OPEN**

- Measure the resistance between driver seat control switch C360 pin 2, circuit 1205 (BK), harness side and ground.

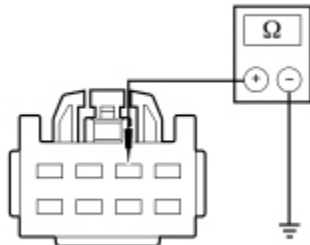

N0013957

**Is the resistance less than 5 ohms?**

<b>Yes</b>	INSTALL a new seat control switch. TEST the system for normal operation. For vehicles equipped with seat side air bags, DISCONNECT the battery ground cable. DISCONNECT the restraint system diagnostic tool from driver seat side air bag module C367. CONNECT driver seat side air bag module C367. REPOWER the SRS. REFER to <a href="#">Section 501-20B</a> .
<b>No</b>	REPAIR the circuit. TEST the system for normal operation. For vehicles equipped with seat side air bags, DISCONNECT the battery ground cable. DISCONNECT the restraint system diagnostic tool from driver seat side air bag module C367. CONNECT driver seat side air bag module C367. REPOWER the SRS. REFER to <a href="#">Section 501-20B</a> .

**Pinpoint Test B: The Power Seat Moves But Is Noisy**

**Normal Operation**

The power seat should move quietly during operation. Some noise is acceptable.

**Possible Causes**

A noisy power seat can be caused by:

- a misaligned seat track.
- a faulty seat track component.
- an object obstructing seat movement.

**PINPOINT TEST B : THE POWER SEAT MOVES BUT IS NOISY**

**B1 CHECK THE TRACK ALIGNMENT**

**⚠️ WARNING:** The restraint system diagnostic tool is for restraint system service only. Remove from vehicle prior to road use. Failure to remove could result in injury and possible violation of vehicle safety standards.

**NOTE:** If a seat equipped with a supplemental restraint system (SRS) component is being serviced, **the SRS must be depowered.** Refer to [Section 501-20B](#).

**NOTE:** The air bag warning lamp illuminates when the RCM fuse is removed and the ignition switch is ON. This is normal operation and does not indicate a supplemental restraint system (SRS) fault.

**NOTE:** The SRS must be fully operational and free of faults before releasing the vehicle to the customer.

- Ignition OFF.
- Depower the SRS. Refer to Supplemental Restraint System (SRS) Depowering and Repowering in the General Procedures portion of [Section 501-20B](#).

**⚠️ WARNING:** Be sure that nobody is in the vehicle and that there is nothing blocking or set in front of any air bag module when the battery ground cable is connected.

For vehicles equipped with seat side air bags, carry out the following:

- Depower the SRS. Refer to Supplemental Restraint System (SRS) Depowering and Repowering in the General Procedures portion of [Section 501-20B](#).

Disconnect driver seat side air bag C367.

Connect restraint system diagnostic tool 418-133 to driver seat side air bag C367.

Connect the battery ground cable.

- Check the alignment of the track to the floor and the track to the seat.

## Is the track out of alignment?

<b>Yes</b>	ALIGN the track to the seat and the floor. TEST the system for normal operation. For vehicles equipped with seat side air bags, DISCONNECT the battery ground cable. DISCONNECT the restraint system diagnostic tool from driver seat side air bag module C367. CONNECT driver seat side air bag module C367. REPOWER the SRS. REFER to <a href="#">Section 501-20B</a> .
<b>No</b>	INSTALL a new seat track. TEST the system for normal operation. For vehicles equipped with seat side air bags, DISCONNECT the battery ground cable. DISCONNECT the restraint system diagnostic tool from driver seat side air bag module C367. CONNECT driver seat side air bag module C367. REPOWER the SRS. REFER to <a href="#">Section 501-20B</a> .

## Pinpoint Test C: The Power Seat Moves But Is Loose

### Normal Operation

The power seat movement should be smooth and the seat cushion should not rock during or after operation.

### Possible Causes

A loose power seat can be caused by:

- loose fastening hardware.
- a faulty seat track component.

## PINPOINT TEST C : THE POWER SEAT MOVES BUT IS LOOSE

### C1 CHECK THE FASTENING HARDWARE

 **WARNING:** The restraint system diagnostic tool is for restraint system service only. Remove from vehicle prior to road use. Failure to remove could result in injury and possible violation of vehicle safety standards.

**NOTE:** If a seat equipped with a supplemental restraint system (SRS) component is being serviced, **the SRS must be depowered.** Refer to [Section 501-20B](#).

**NOTE:** The air bag warning lamp illuminates when the RCM fuse is removed and the ignition switch is ON. This is normal operation and does not indicate a supplemental restraint system (SRS) fault.

**NOTE:** The SRS must be fully operational and free of faults before releasing the vehicle to the customer.

- Ignition OFF.
- Depower the SRS. Refer to Supplemental Restraint System (SRS) Depowering and Repowering in the General Procedures portion of [Section 501-20B](#).

 **WARNING:** Be sure that nobody is in the vehicle and that there is nothing blocking or set in front of any air bag module when the battery ground cable is connected.

For vehicles equipped with seat side air bags, carry out the following:

- Depower the SRS. Refer to Supplemental Restraint System (SRS) Depowering and Repowering in the General Procedures portion of [Section 501-20B](#).

Disconnect driver seat side air bag C367.

Connect restraint system diagnostic tool 418-133 to driver seat side air bag C367.

Connect the battery ground cable.

- Inspect the seat fastening hardware.

## Is the fastening hardware loose?

<b>Yes</b>	TIGHTEN all fastening hardware to specification. TEST the system for normal operation. For vehicles equipped with seat side air bags, DISCONNECT the battery ground cable. DISCONNECT the restraint system diagnostic tool from driver seat side air bag module C367. CONNECT driver seat side air bag module C367. REPOWER the SRS. REFER to <a href="#">Section 501-20B</a> .
<b>No</b>	IDENTIFY the cause and INSTALL a new seat track component. TEST the system for normal operation. For vehicles equipped with seat side air bags, DISCONNECT the battery ground cable. DISCONNECT the restraint system diagnostic tool from driver seat side air bag module C367. CONNECT driver seat side air bag module C367. REPOWER the SRS. REFER to <a href="#">Section 501-20B</a> .

## Pinpoint Test D: The Power Seat Does Not Make Full Travel

### Normal Operation

The power seat should travel fully horizontal (FORWARD/REARWARD) and vertical (front UP/DOWN and rear UP/DOWN).

### Possible Causes

A power seat that does not make full travel can be caused by:

- an obstruction.
- a faulty seat track component.

### PINPOINT TEST D : THE POWER SEAT DOES NOT MAKE FULL TRAVEL

#### D1 CHECK FOR AN OBSTRUCTION IN THE SEAT TRACK

 **WARNING:** The restraint system diagnostic tool is for restraint system service only. Remove from vehicle prior to road use. Failure to remove could result in injury and possible violation of vehicle safety standards.

**NOTE:** If a seat equipped with a supplemental restraint system (SRS) component is being serviced, **the SRS must be depowered.** Refer to [Section 501-20B](#).

**NOTE:** The air bag warning lamp illuminates when the RCM fuse is removed and the ignition switch is ON. This is normal operation and does not indicate a supplemental restraint system (SRS) fault.

**NOTE:** The SRS must be fully operational and free of faults before releasing the vehicle to the customer.

- Ignition OFF.
- Depower the SRS. Refer to Supplemental Restraint System (SRS) Depowering and Repowering in the General Procedures portion of [Section 501-20B](#).

 **WARNING:** Be sure that nobody is in the vehicle and that there is nothing blocking or set in front of any air bag module when the battery ground cable is connected.

For vehicles equipped with seat side air bags, carry out the following:

- Depower the SRS. Refer to Supplemental Restraint System (SRS) Depowering and Repowering in the General Procedures portion of [Section 501-20B](#).  
Disconnect driver seat side air bag C367.  
Connect restraint system diagnostic tool 418-133 to driver seat side air bag C367.  
Connect the battery ground cable.
- Remove the affected seat. Refer to [Seat — Front](#) in this section.

#### Are there any obstructions in the track?

<b>Yes</b>	REMOVE the obstruction(s) and GREASE the track(s). TEST the system for normal operation. For vehicles equipped with seat side air bags, DISCONNECT the battery ground cable. DISCONNECT the restraint system diagnostic tool from driver seat side air bag module C367. CONNECT driver seat side air bag module C367. REPOWER the SRS. REFER to <a href="#">Section 501-20B</a> .
<b>No</b>	IDENTIFY the cause and INSTALL a new seat track component. TEST the system for normal operation. For vehicles equipped with seat side air bags, DISCONNECT the battery ground cable. DISCONNECT the restraint system diagnostic tool from driver seat side air bag module C367. CONNECT driver seat side air bag module C367. REPOWER the SRS. REFER to <a href="#">Section 501-20B</a> .

## Pinpoint Test E: The Power Seat Does Not Move Horizontally/Vertically

### Normal Operation

The seat control switch is powered by battery voltage on circuit 566 (DG) and is supplied ground on circuit 1205 (BK). When pressed, the seat control switch supplies that voltage and ground to a power seat track motor to move the seat. When pressed in the opposite direction, the power seat switch reverses the polarity to the power seat track motor, which moves the seat in the opposite direction.



There are 3 power seat track motors that combine to move the seat horizontally (FORWARD/REVERSE) and vertically (front UP/DOWN and rear UP/DOWN).

**Possible Causes**

A power seat that does not move horizontally and/or vertically can be caused by:

- wiring, terminals or connectors.
- a faulty seat control switch.
- a faulty seat track motor.

**PINPOINT TEST E : THE POWER SEAT DOES NOT MOVE HORIZONTALLY/VERTICALLY**

**E1 DETERMINE WHICH DIRECTION HAS FAILED**

 **WARNING:** The restraint system diagnostic tool is for restraint system service only. Remove from vehicle prior to road use. Failure to remove could result in injury and possible violation of vehicle safety standards.

**NOTE:** If a seat equipped with a supplemental restraint system (SRS) component is being serviced, **the SRS must be depowered.** Refer to [Section 501-20B](#).

**NOTE:** The air bag warning lamp illuminates when the RCM fuse is removed and the ignition switch is ON. This is normal operation and does not indicate a supplemental restraint system (SRS) fault.

**NOTE:** The SRS must be fully operational and free of faults before releasing the vehicle to the customer.

- Ignition OFF.
- Depower the SRS. Refer to Supplemental Restraint System (SRS) Depowering and Repowering in the General Procedures portion of [Section 501-20B](#).

 **WARNING:** Be sure that nobody is in the vehicle and that there is nothing blocking or set in front of any air bag module when the battery ground cable is connected.

For vehicles equipped with seat side air bags, carry out the following:

- Depower the SRS. Refer to Supplemental Restraint System (SRS) Depowering and Repowering in the General Procedures portion of [Section 501-20B](#).

Disconnect driver seat side air bag C367.

Connect restraint system diagnostic tool 418-133 to driver seat side air bag C367.

Connect the battery ground cable.

- Push the driver or passenger seat control switch to the front and rear.

**Does the power seat move to the front and rear?**

<b>Yes</b>	GO to <a href="#">E2</a> .
<b>No</b>	GO to <a href="#">E9</a> .

**E2 DETERMINE POWER SEAT TILTING FAILURE**

- Verify the power seat tilting feature.

**Can the power seat be tilted forward and rearward?**

<b>Yes</b>	If only the forward tilting operates, GO to <a href="#">E3</a> . If only the rearward tilting operates, GO to <a href="#">E6</a> .
<b>No</b>	INSTALL a new seat control switch. TEST the system for normal operation. For vehicles equipped with seat side air bags, DISCONNECT the battery ground cable. DISCONNECT the restraint system diagnostic tool from driver seat side air bag module C367. CONNECT driver seat side air bag module C367. REPOWER the SRS. REFER to <a href="#">Section 501-20B</a> .

**E3 CHECK THE VOLTAGE TO THE REAR HEIGHT MOTOR**

- Disconnect: Driver Power Seat Motor Assembly C353.
- Measure the voltage between driver power seat motor assembly C353 pin 8, circuit 983 (RD/LG) and pin 2, circuit 983 (RD/LG), harness side, while pushing the seat control switch rear UP and rear DOWN.

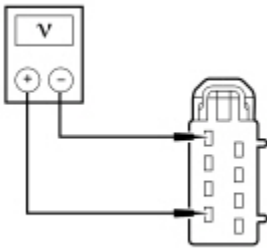

N0013778

Is the voltage greater than 10 volts when the seat control switch is in the rear UP position, greater than negative (-) 10 volts in the rear DOWN position and 0 volts in the NEUTRAL position?

<b>Yes</b>	INSTALL a new driver seat track assembly. TEST the system for normal operation. For vehicles equipped with seat side air bags, DISCONNECT the battery ground cable. DISCONNECT the restraint system diagnostic tool from driver seat side air bag module C367. CONNECT driver seat side air bag module C367. REPOWER the SRS. REFER to <a href="#">Section 501-20B</a> .
<b>No</b>	GO to <a href="#">E4</a> .

#### E4 CHECK CIRCUIT 983 (RD/LG) FOR AN OPEN

- Disconnect: Driver Seat Control Switch C360.
- Measure the resistance between driver seat control switch C360 pin 5, circuit 983 (RD/LG), harness side and driver power seat motor assembly C353 pin 8, circuit 983 (RD/LG), harness side.

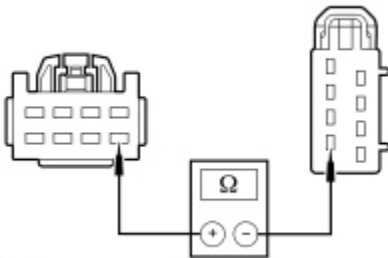

N0013779

Is the resistance less than 5 ohms?

<b>Yes</b>	GO to <a href="#">E5</a> .
<b>No</b>	REPAIR the circuit. TEST the system for normal operation. For vehicles equipped with seat side air bags, DISCONNECT the battery ground cable. DISCONNECT the restraint system diagnostic tool from driver seat side air bag module C367. CONNECT driver seat side air bag module C367. REPOWER the SRS. REFER to <a href="#">Section 501-20B</a> .

#### E5 CHECK CIRCUIT 982 (YE/LG) FOR AN OPEN

- Measure the resistance between driver seat control switch C360 pin 7, circuit 982 (YE/LG), harness side and driver power seat motor assembly C353 pin 2, circuit 982 (YE/LG), harness side.

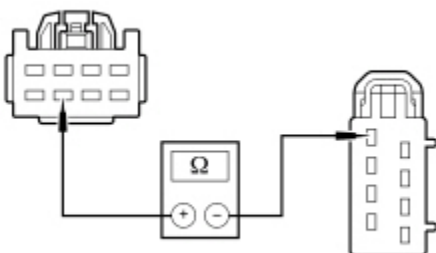

N0013780

**Is the resistance less than 5 ohms?**

<b>Yes</b>	INSTALL a new driver seat control switch. TEST the system for normal operation. For vehicles equipped with seat side air bags, DISCONNECT the battery ground cable. DISCONNECT the restraint system diagnostic tool from driver seat side air bag module C367. CONNECT driver seat side air bag module C367. REPOWER the SRS. REFER to <a href="#">Section 501-20B</a> .
<b>No</b>	REPAIR the circuit. TEST the system for normal operation. For vehicles equipped with seat side air bags, DISCONNECT the battery ground cable. DISCONNECT the restraint system diagnostic tool from driver seat side air bag module C367. CONNECT driver seat side air bag module C367. REPOWER the SRS. REFER to <a href="#">Section 501-20B</a> .

**E6 CHECK THE VOLTAGE TO THE FRONT HEIGHT MOTOR**

- Disconnect: Driver Power Seat Motor Assembly C353.
- Measure the voltage between driver power seat motor assembly C353 pin 1, circuit 979 (RD/LB) and pin 7, circuit 990 (YE/LB), harness side while pushing the driver seat control switch front UP and front DOWN.

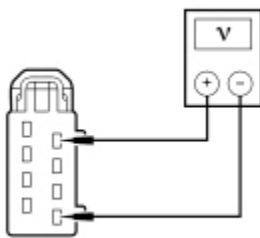

N0013781

**Is the voltage greater than 10 volts when the seat control switch front height adjustment is in the front UP position, greater than negative (-) 10 volts in the front DOWN position and 0 volts in the NEUTRAL position?**

<b>Yes</b>	INSTALL a new driver seat track assembly. TEST the system for normal operation. For vehicles equipped with seat side air bags, DISCONNECT the battery ground cable. DISCONNECT the restraint system diagnostic tool from driver seat side air bag module C367. CONNECT driver seat side air bag module C367. REPOWER the SRS. REFER to <a href="#">Section 501-20B</a> .
<b>No</b>	GO to <a href="#">E7</a> .

**E7 CHECK CIRCUIT 979 (RD/LB) FOR AN OPEN**

- Disconnect: Driver Seat Control Switch C360.
- Measure the resistance between driver seat control switch C360 pin 1, circuit 979 (RD/LB), harness side and driver power seat motor assembly C353 pin 1, circuit 979 (RD/LB), harness side.

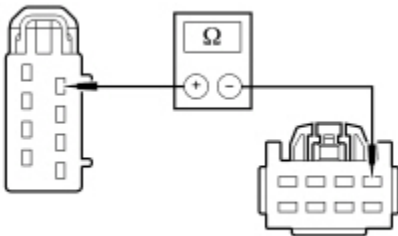

N0013782

**Is the resistance less than 5 ohms?**

<b>Yes</b>	GO to <a href="#">E8</a> .
<b>No</b>	REPAIR the circuit. TEST the system for normal operation. For vehicles equipped with seat side air bags, DISCONNECT the battery ground cable. DISCONNECT the

restraint system diagnostic tool from driver seat side air bag module C367. CONNECT driver seat side air bag module C367. REPOWER the SRS. REFER to [Section 501-20B](#).

### E8 CHECK CIRCUIT 990 (YE/LB) FOR AN OPEN

- Measure the resistance between driver seat control switch C360 pin 8, circuit 990 (YE/LB), harness side and driver power seat motor assembly C353 pin 7, circuit 990 (YE/LB), harness side.

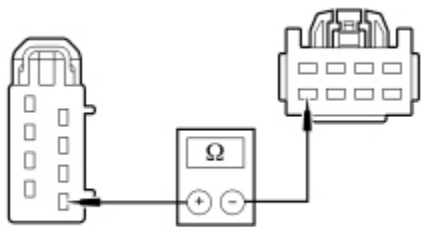

N0013783

Is the resistance less than 5 ohms?

<b>Yes</b>	INSTALL a new driver seat control switch. TEST the system for normal operation. For vehicles equipped with seat side air bags, DISCONNECT the battery ground cable. DISCONNECT the restraint system diagnostic tool from driver seat side air bag module C367. CONNECT driver seat side air bag module C367. REPOWER the SRS. REFER to <a href="#">Section 501-20B</a> .
<b>No</b>	REPAIR the circuit. TEST the system for normal operation. For vehicles equipped with seat side air bags, DISCONNECT the battery ground cable. DISCONNECT the restraint system diagnostic tool from driver seat side air bag module C367. CONNECT driver seat side air bag module C367. REPOWER the SRS. REFER to <a href="#">Section 501-20B</a> .

### E9 CHECK THE VOLTAGE TO THE HORIZONTAL MOTOR

- Disconnect: Driver Power Seat Motor Assembly C353.
- Measure the voltage between driver power seat motor assembly C353 pin 3, circuit 981 (RD/WH) and pin 5, circuit 980 (YE/WH), harness side while pushing the seat control switch FORWARD and REARWARD.

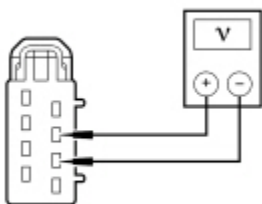

N0013784

Is the voltage greater than 10 volts when the seat control switch is in the REARWARD position, greater than negative (-) 10 volts in the FORWARD position and 0 volts in the NEUTRAL position?

<b>Yes</b>	INSTALL a new driver seat track assembly. TEST the system for normal operation. For vehicles equipped with seat side air bags, DISCONNECT the battery ground cable. DISCONNECT the restraint system diagnostic tool from driver seat side air bag module C367. CONNECT driver seat side air bag module C367. REPOWER the SRS. REFER to <a href="#">Section 501-20B</a> .
<b>No</b>	GO to <a href="#">E10</a> .

### E10 CHECK CIRCUIT 981 (RD/WH) FOR AN OPEN

- Disconnect: Driver Seat Control Switch C360.

- Measure the resistance between driver seat control switch C360 pin 6, circuit 981 (RD/WH), harness side, and driver power seat motor assembly C353 pin 3, circuit 981 (RD/WH), harness side.

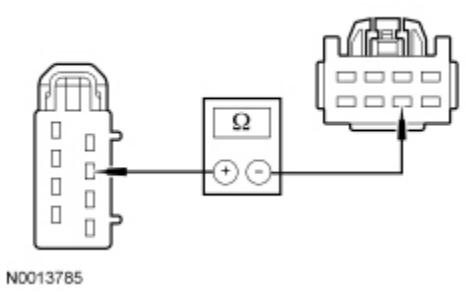

**Is the resistance less than 5 ohms?**

<b>Yes</b>	GO to <a href="#">E11</a> .
<b>No</b>	REPAIR the circuit. TEST the system for normal operation. For vehicles equipped with seat side air bags, DISCONNECT the battery ground cable. DISCONNECT the restraint system diagnostic tool from driver seat side air bag module C367. CONNECT driver seat side air bag module C367. REPOWER the SRS. REFER to <a href="#">Section 501-20B</a> .

**E11 CHECK CIRCUIT 980 (YE/WH) FOR AN OPEN**

- Measure the resistance between driver seat control switch C360 pin 3, circuit 980 (YE/WH), harness side and driver power seat motor assembly C353 pin 5, circuit 980 (YE/WH), harness side.

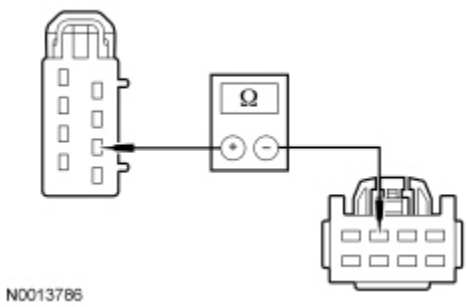

**Is the resistance less than 5 ohms?**

<b>Yes</b>	INSTALL a new driver seat control switch. TEST the system for normal operation. For vehicles equipped with seat side air bags, DISCONNECT the battery ground cable. DISCONNECT the restraint system diagnostic tool from driver seat side air bag module C367. CONNECT driver seat side air bag module C367. REPOWER the SRS. REFER to <a href="#">Section 501-20B</a> .
<b>No</b>	REPAIR the circuit. TEST the system for normal operation. For vehicles equipped with seat side air bags, DISCONNECT the battery ground cable. DISCONNECT the restraint system diagnostic tool from driver seat side air bag module C367. CONNECT driver seat side air bag module C367. REPOWER the SRS. REFER to <a href="#">Section 501-20B</a> .

**Pinpoint Test F: The Power Lumbar Is Inoperative**

**Normal Operation**

The lumbar control switch is powered by battery voltage on circuit 566 (DG) and is supplied ground on circuit 1205 (BK). When the knob of the lumbar control switch is pressed, voltage and ground are supplied to the power lumbar motor. When pressing the lumbar knob in the opposite direction, the lumbar control switch reverses the polarity to the power lumbar motor, which moves the lumbar mechanism in the opposite direction.

**Possible Causes**

An inoperative power lumbar can be caused by:

- wiring, terminals or connectors.
- a faulty lumbar control switch.
- a faulty power lumbar motor assembly.

**PINPOINT TEST F : THE POWER LUMBAR IS INOPERATIVE**

**F1 CHECK CIRCUIT 566 (DG) FOR AN OPEN**

**⚠ WARNING:** The restraint system diagnostic tool is for restraint system service only. Remove from vehicle prior to road use. Failure to remove could result in injury and possible violation of vehicle safety standards.

**NOTE:** If a seat equipped with a supplemental restraint system (SRS) component is being serviced, **the SRS must be depowered.** Refer to [Section 501-20B](#).

**NOTE:** The air bag warning lamp illuminates when the RCM fuse is removed and the ignition switch is ON. This is normal operation and does not indicate a supplemental restraint system (SRS) fault.

**NOTE:** The SRS must be fully operational and free of faults before releasing the vehicle to the customer.

- Ignition OFF.
- Depower the SRS. Refer to Supplemental Restraint System (SRS) Depowering and Repowering in the General Procedures portion of [Section 501-20B](#).

**⚠ WARNING:** Be sure that nobody is in the vehicle and that there is nothing blocking or set in front of any air bag module when the battery ground cable is connected.

For vehicles equipped with seat side air bags, carry out the following:

- Depower the SRS. Refer to Supplemental Restraint System (SRS) Depowering and Repowering in the General Procedures portion of [Section 501-20B](#).

Disconnect driver seat side air bag C367.

Connect restraint system diagnostic tool 418-133 to driver seat side air bag C367.

Connect the battery ground cable.

- Disconnect: Lumbar Control Switch C361.
- Measure the voltage between lumbar control switch C361 pin 4, circuit 566 (DG), harness side and ground.

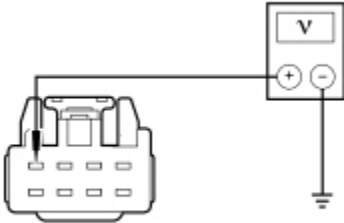

N0013787

**Is the voltage greater than 10 volts?**

<b>Yes</b>	GO to <a href="#">F2</a> .
<b>No</b>	REPAIR the circuit. TEST the system for normal operation. For vehicles equipped with seat side air bags, DISCONNECT the battery ground cable. DISCONNECT the restraint system diagnostic tool from driver seat side air bag module C367. CONNECT driver seat side air bag module C367. REPOWER the SRS. REFER to <a href="#">Section 501-20B</a> .

**F2 CHECK CIRCUIT 1205 (BK) FOR AN OPEN**

- Measure the resistance between lumbar control switch C361 pin 2, circuit 1205 (BK), harness side and ground; and between lumbar control switch C361 pin 8, circuit 1205 (BK), harness side and ground.

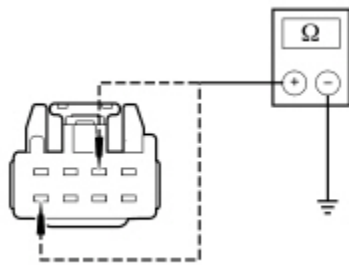

N0013788

**Are the resistances less than 5 ohms?**

<b>Yes</b>	GO to GO to <a href="#">F3</a> .
<b>No</b>	REPAIR the circuit. TEST the system for normal operation. For vehicles equipped with seat side air bags, DISCONNECT the battery ground cable. DISCONNECT the restraint system diagnostic tool from driver seat side air bag module C367. CONNECT driver seat side air bag module C367. REPOWER the SRS. REFER to <a href="#">Section 501-20B</a> .

### F3 CHECK THE LUMBAR MOTOR

- Connect: Lumbar Control Switch C361.
- Disconnect: Power Lumbar Motor C366.
- Measure the voltage between power lumbar motor C366 pin 1, circuit 1097 (BN), harness side and power lumbar motor C366 pin 2, circuit 1094 (PK), harness side.

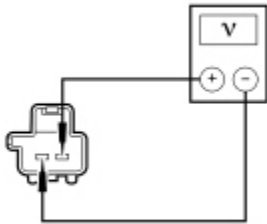

N0013789

- Operate the power lumbar control switch in both directions.

**Is the voltage greater than 10 volts in both directions?**

<b>Yes</b>	INSTALL a new power lumbar assembly. TEST the system for normal operation. For vehicles equipped with seat side air bags, DISCONNECT the battery ground cable. DISCONNECT the restraint system diagnostic tool from driver seat side air bag module C367. CONNECT driver seat side air bag module C367. REPOWER the SRS. REFER to <a href="#">Section 501-20B</a> .
<b>No</b>	GO to <a href="#">F4</a> .

### F4 CHECK CIRCUIT 1094 (PK) AND CIRCUIT 1097 (BN) FOR A SHORT TO GROUND

- Disconnect: Lumbar Control Switch C361.
- Measure the resistance between lumbar control switch C361 pin 3, circuit 1094 (PK), harness side and ground; and between lumbar control switch C361 pin 1, circuit 1097 (BN), harness side and ground.

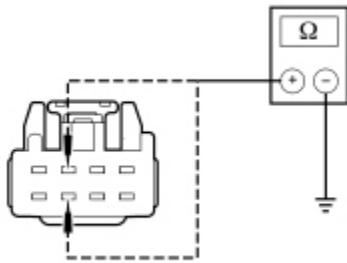

N0013790

Are the resistances greater than 10,000 ohms.

<b>Yes</b>	GO to GO to <a href="#">F5</a> .
<b>No</b>	REPAIR the circuit. TEST the system for normal operation. For vehicles equipped with seat side air bags, DISCONNECT the battery ground cable. DISCONNECT the restraint system diagnostic tool from driver seat side air bag module C367. CONNECT driver seat side air bag module C367. REPOWER the SRS. REFER to <a href="#">Section 501-20B</a> .

### F5 CHECK CIRCUIT 1094 (PK) AND CIRCUIT 1097 (BN) FOR AN OPEN

- Measure the resistance between power lumbar control switch C361 pin 3, circuit 1097 (BN), harness side and power lumbar motor C366 pin 1, circuit 1097 (BN), harness side; and between lumbar control switch C361 pin 7, circuit 1094 (PK), harness side and power lumbar motor C366 pin 2, circuit 1094 (PK), harness side.

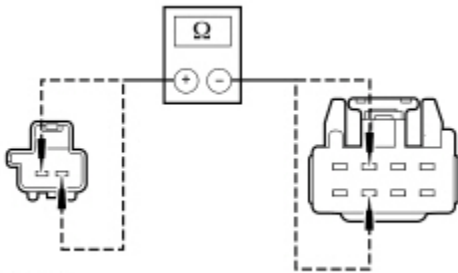

N0013791

Are the resistances less than 5 ohms?

<b>Yes</b>	INSTALL a new lumbar control switch. TEST the system for normal operation. For vehicles equipped with seat side air bags, DISCONNECT the battery ground cable. DISCONNECT the restraint system diagnostic tool from driver seat side air bag module C367. CONNECT driver seat side air bag module C367. REPOWER the SRS. REFER to <a href="#">Section 501-20B</a> .
<b>No</b>	REPAIR the circuit. TEST the system for normal operation. For vehicles equipped with seat side air bags, DISCONNECT the battery ground cable. DISCONNECT the restraint system diagnostic tool from driver seat side air bag module C367. CONNECT driver seat side air bag module C367. REPOWER the SRS. REFER to <a href="#">Section 501-20B</a> .



