

US INSTALLATION INSTRUCTION - REAR SPOILER

E INSTRUCCIONES DE INSTALACION - ALERÓN TRASERO

F INSTRUCTIONS D'INSTALLATION - BECQUET ARRIÈRE



Subject to alteration without notice
Reservadas modificaciones técnicas
Sous réserve de modifications techniques

SHELBY MUSTANG 2005 - 2008

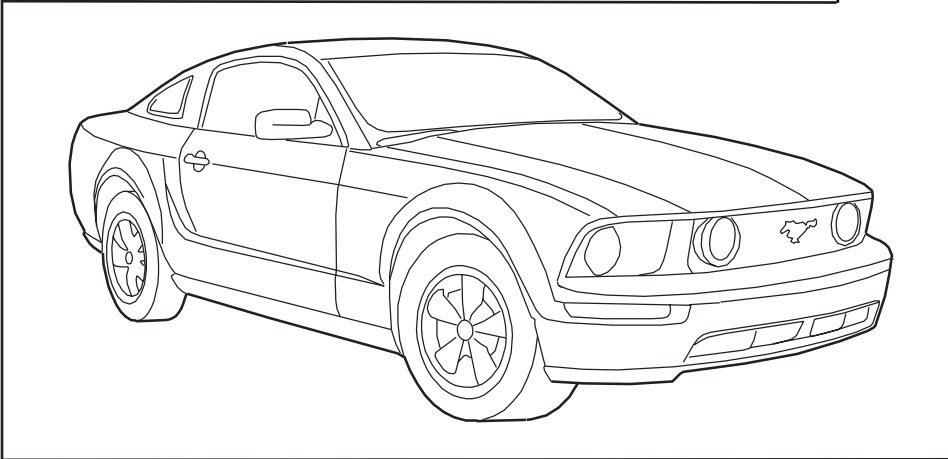

PERSONAL INJURY
LESIONES PERSONALES
RISQUE DE BLESSURE



VEHICLE DAMAGE
DANO DE VEHICULO
DOMMAGE AU VÉHICULE



INCORRECT
INCORRECTO
INCORRECT



CORRECT
CORRECTO
CORRECT



SEE MANUAL
VER MANUAL
VOIR LE MANUEL

A

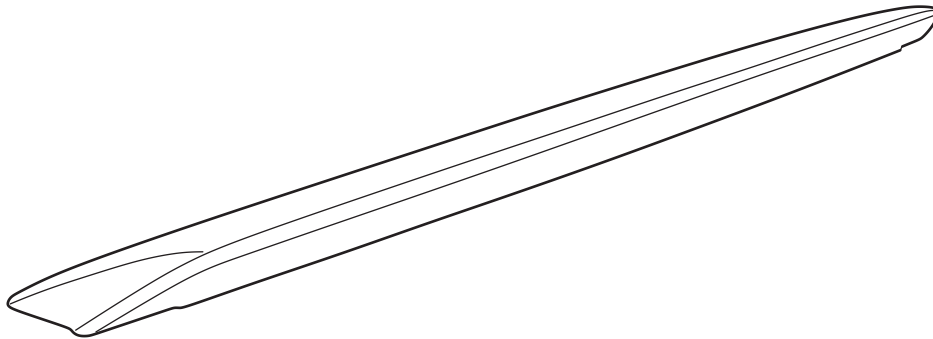

B

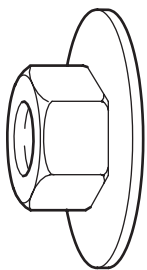

4x

C

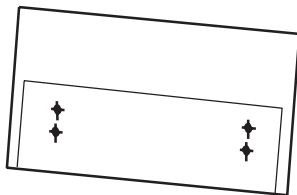

TOOLS REQUIRED
HERRAMIENTAS NECESARIAS
OUTILS NÉCESSAIRES

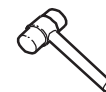
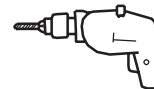
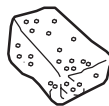

10mm

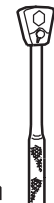

6mm



3mm

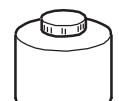

PM-12-A



1

2

NOTE: MASK INDICATED AREAS PRIOR TO PAINTING.
 NOTA: CUBRA LAS ÁREAS INDICADAS CON CINTA DE ENMASCARAR ANTES DE PINTAR.
 REMARQUE : MASQUER LES SURFACES INDIQUÉES AVANT DE PEINDRE.

3

NOTE: PAINT TO MATCH
 NOTA: PINTE PARA COMBINAR
 REMARQUE : PEINDRE AUX COULEURS DE LA CARROSSERIE

5

6

NOTE: ALIGN EDGE OF TEMPLATE TO THE FRONT LEFT AND RIGHT SIDES OF DECKLID
 NOTA: ALINEE EL BORDE DE LA PLANTILLA HACIA LA PARTE DELANTERA DEL LADO DERECHO E IZQUIERDO DE LA PUERTA DE LA CAJUELA
 REMARQUE : ALIGNER LES REBORDS DU GABARIT AVEC LES CÔTÉS GAUCHE ET DROIT DU COUVERCLE DE COFFRE

<p>7</p>	<p>8</p>
<p>9</p>	<p>10</p>
<p>11</p> <div style="display: flex; justify-content: space-between; align-items: center;"> <div style="border: 1px solid black; padding: 2px;"> <p>5-10 MIN</p> </div> <div style="display: flex; gap: 10px;"> <div style="border: 1px solid black; padding: 2px; text-align: center;"> <p>PM-12-A</p> </div> <div style="border: 1px solid black; padding: 2px;"> </div> </div> </div> <div style="margin-top: 20px;"> <p>NOTE: APPLY PM-12-A TO THE INNER AND OUTER AREAS OF THE DECKLID</p> <p>NOTA: APLIQUE PM-12 A EN LA PARTE INTERIOR Y EXTERIOR DE LA PUERTA DE LA CAJUELA</p> <p>REMARQUE : ENDUIRE DE PM-12-A LES SURFACES INTERNES ET EXTERNES DU COUVERCLE DE COFFRE</p> </div>	

12

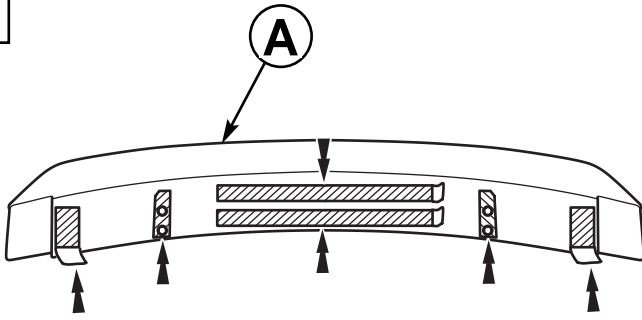

NOTE: REMOVE ADHESIVE / MASKING BACKING PRIOR TO INSTALLATION OF SPOILER
 NOTA: RETIRE LA PELÍCULA ADHESIVA / CINTA DE ENMASCARAR ANTES DE INSTALAR EL ALERÓN
 REMARQUE : RETIRER LA PROTECTION DE L'ADHÉSIF OU DU RUBAN CACHE AVANT D'INSTALLER LE BECQUET

13

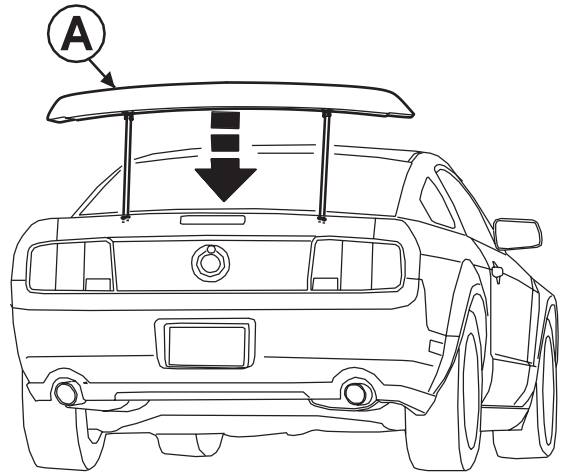

14

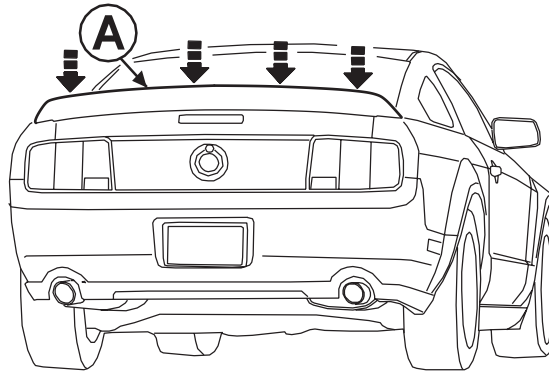

PUSH DOWN ALONG FRONT AND REAR EDGES OF SPOILER WITH 20lbs (9kg) OF PRESSURE FOR 30 SECONDS.

EJERZA UNA PRESIÓN DE 20 libras (9kg) A LO LARGO DE LOS BORDES FRONTAL Y TRASERO DEL ALERÓN DURANTE 30 SEGUNDOS.

APPUYER SUR LES BORDS AVANT ET ARRIÈRE DU BECQUET AVEC UNE PRESSION DE 20 lbs (9kg) PENDANT 30 SECONDES.

15

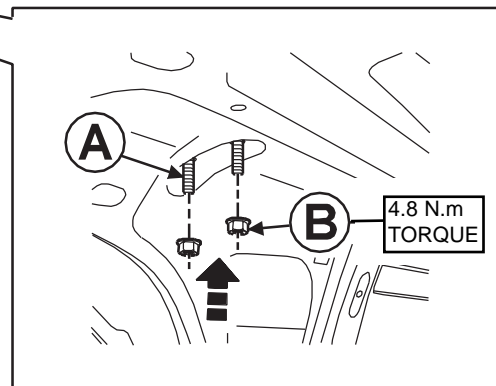
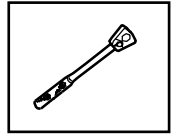
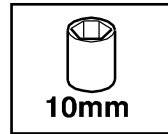
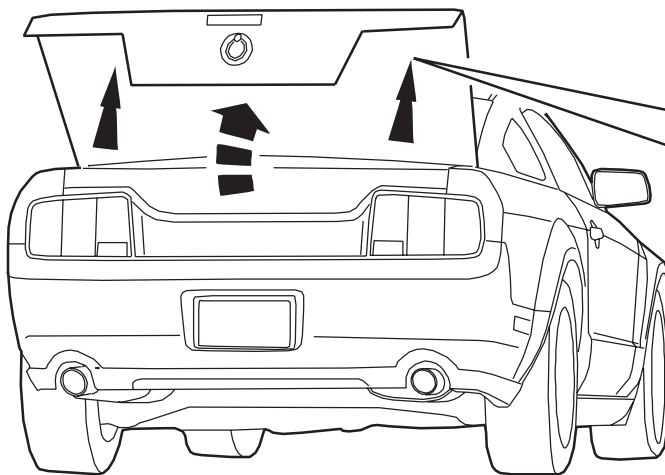

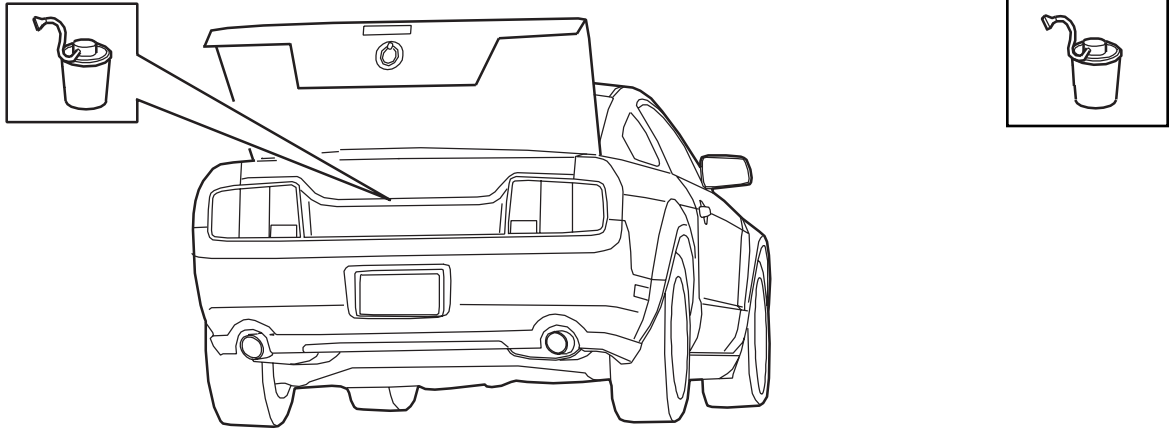

NOTE: VACUUM SHAVINGS AND DEBRIS FROM TRUNK AREA

NOTA: ASPIRE LAS ASTILLAS Y DESECHOS DEL ÁREA DE LA CAJUELA

REMARQUE : UTILISER UN ASPIRATEUR POUR RETIRER LES COPEAUX ET DÉBRIS DU COFFRE

Congratulations!

You've purchased a Genuine Ford Brand Accessory designed, engineered, and built specifically for your Ford vehicle. We have made every effort to ensure that the Rear Spoiler is top quality in terms of fit, durability, finish and ease of installation.

At Ford Customer Service Division,
customer satisfaction is our number one priority!

Felicitaciones.

Usted ha comprado un Accesorio marca Ford Genuino, diseñado y construido específicamente para su vehículo Ford. Hemos realizado todos los esfuerzos necesarios para que este alerón trasero sea de la mejor calidad en cuanto a ajuste, durabilidad acabado y facilidad de instalación.

Para la División de Atención al Cliente de Ford,
la satisfacción del cliente es nuestra principal prioridad.

Félicitations!

Vous avez choisi un accessoire Ford d'origine conçu et fabriqué spécifiquement pour votre véhicule Ford. Aucun effort n'a été épargné pour vous offrir un becquet arrière durable, de grande qualité, facile à poser, qui s'ajuste parfaitement et qui met en valeur l'esthétique de votre véhicule.

La priorité la plus importante de la Division du service à la clientèle de Ford
est d'assurer l'entière satisfaction du client!



Ford Customer Service Division

