

US

INSTALLATION INSTRUCTION - MOBILE- EASE HANDS FREE CELL PHONE SYSTEM

E

INSTRUCCIONES DE INSTALACION - SISTEMA DE TELÉFONO MÓVIL MANOS LIBRES

F

INSTRUCTIONS D'INSTALLATION - SYSTÈME DE TÉLÉPHONE CELLULAIRE
MAINS LIBRES MOBILE-EASE



LINCOLN

Mercury



ACCESSORIZE YOUR VEHICLE AT: WWW.FORDACCESSORIESSTORE.COM

Subject to alteration without notice
Reservadas modificaciones técnicas
Sous réserve de modifications techniques

2008.5 Mustang Coupe →

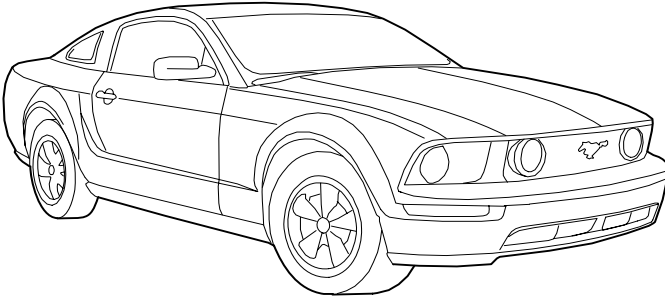

PERSONAL INJURY
LESIONES PERSONALES
RISQUE DE BLESSURE



VEHICLE DAMAGE
DANO DE VEHICULO
DOMMAGE AU VEHICULE







INCORRECT
INCORRECTO
INCORRECT



CORRECT
CORRECTO
CORRECT

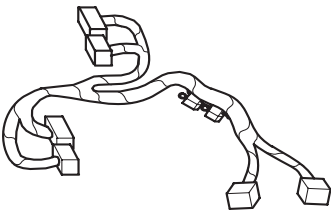
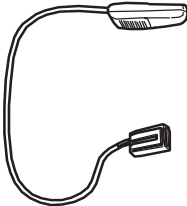
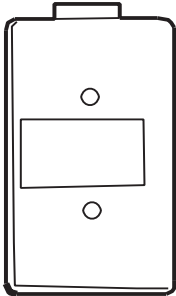
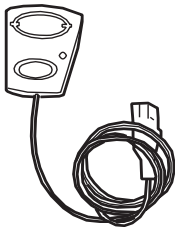

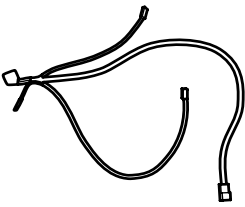
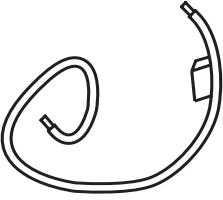
SEE MANUAL
VER MANUAL
VOIR LE MANUEL

| | | | | |
|---|---|--|--|--|
| <p>A</p>  <p>REQUIRED PART SOLD SEPARATELY LA PARTE REQUERIDA VENDIÓ POR SEPARADO LA PARTIE EXIGÉE S'EST VENDUE SÉPARÉMENT (BASE # 14A411)</p> | <p>B</p>  | <p>C</p>  | <p>D</p>  | <p>E</p>  |
| <p>F</p>  | <p>G</p>  | <p>H</p>  <p>REQUIRED PART SOLD SEPARATELY LA PARTE REQUERIDA VENDIÓ POR SEPARADO LA PARTIE EXIGÉE S'EST VENDUE SÉPARÉMENT (BASE # 14A411)</p> | <p>I</p>  | |

TOOLS REQUIRED
HERRAMIENTAS NECESARIAS
OUTILS NECESSAIRES

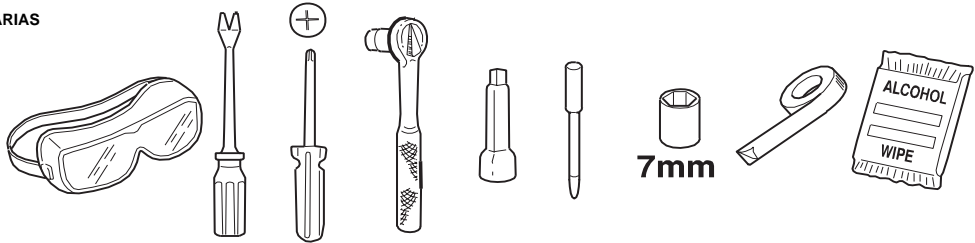

ALCOHOL
WIPE

7mm



1

NOTE: TO INSURE PROPER INSTALLATION, USE THE FOLLOWING GUIDELINES:
 APPLY FLOCK TAPE TO SHARP OR JAGGED AREAS DURING INSTALLATION OF WIRING HARNESS
 APPLY FLOCK TAPE TO WIRE HARNESS IN AREAS WHERE SQUEAK AND RATTLE CONDITIONS MAY OCCUR
 SECURE WIRE HARNESS AT LEAST 6mm FROM EXISTING SENSORS OR MODULES
 AVOID ANY MOVING PARTS ie; VACUUM MOTORS, etc.

NOTA: PARA ASEGURAR UNA INSTALACIÓN ADECUADA, PONGA EN PRÁCTICA LAS SIGUIENTES RECOMENDACIONES:
 APLIQUE CINTA AFIELTRADA (FLOC) EN LAS ÁREAS FILOSAS O DENTADAS DURANTE LA INSTALACIÓN DEL MAZO DE CABLES
 APLIQUE CINTA AFIELTRADA (FLOC) AL MAZO DE CABLES EN CUALQUIER ÁREA DONDE PODRÍAN PRODUCIRSE CHIRRIDOS O TRAQUETEOS
 FIJE EL MAZO DE CABLES A UNA DISTANCIA DE AL MENOS 6 mm RESPECTO DE LOS SENSORES O MÓDULOS INSTALADOS
 EVITE LAS PIEZAS MÓVILES, COMO LOS MOTORES DE VACÍO, ETC.

REMARQUE : POUR ASSURER UNE INSTALLATION CORRECTE, UTILISER LES DIRECTIVES SUIVANTES :
 APPLIQUER DU RUBAN FLOQUÉ SUR LES PIÈCES TRANCHANTES OU ACÉRÉES PENDANT L'INSTALLATION DU FAISCEAU DE FILS.
 APPLIQUER DU RUBAN FLOQUÉ SUR LES PARTIES DU FAISCEAU DE FILS RISQUANT DE PRODUIRE DES GRINCEMENTS OU DES VIBRATIONS.
 ASSUJETTIR LE FAISCEAU DE FILS À AU MOINS 6 mm DES MODULES ET CAPTEURS PRÉSENTS.
 ÉVITER LES PIÈCES EN MOUVEMENT TELS QUE LES MOTEURS À VIDE, ETC.

2

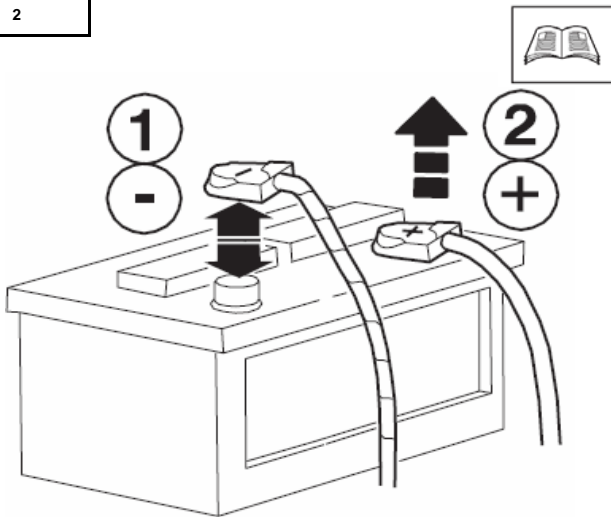

3

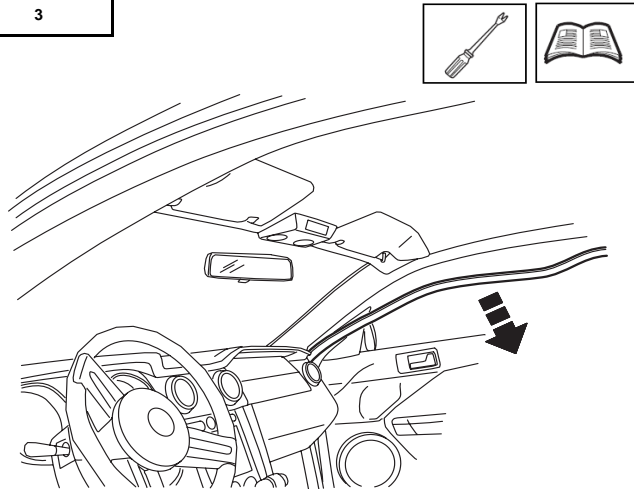

NOTE: REMOVE WEATHERSTRIP
NOTA: QUITE LA GOMA SELLADORA
REMARQUE : RETIRER LE JOINT D'ÉTANCHÉITÉ

4

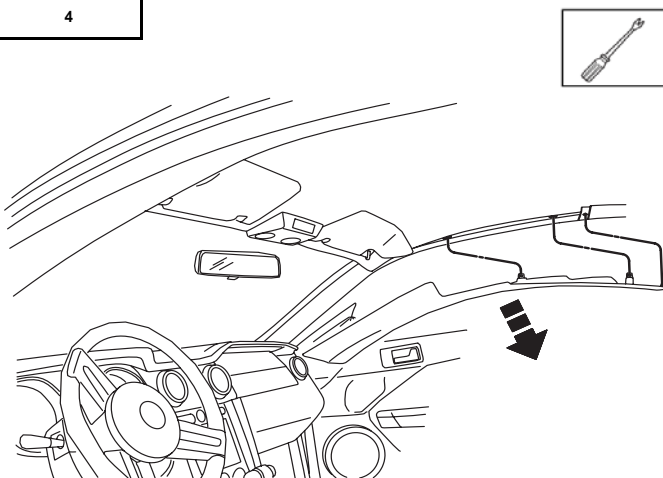

5

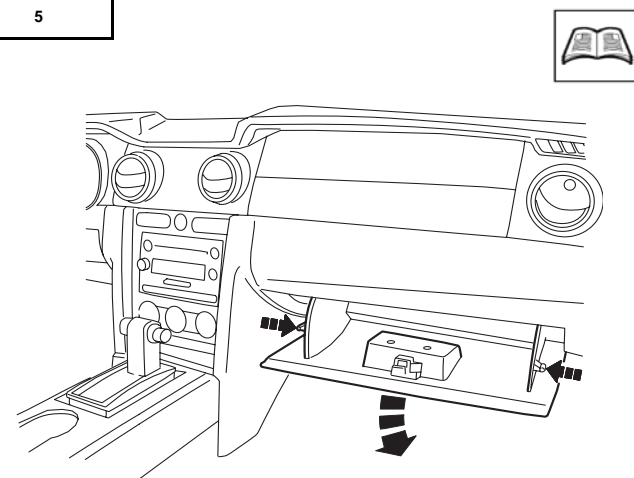

6

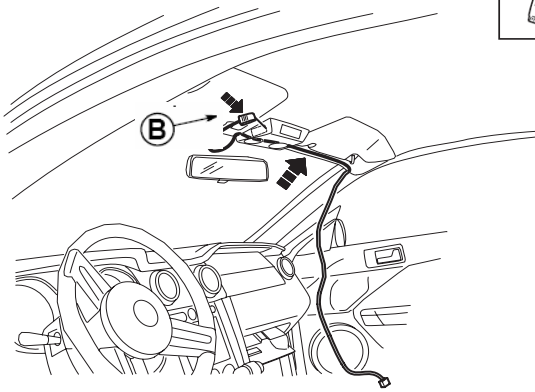

NOTE: CLEAN AREA WITH ALCOHOL WIPE REMOVE ADHESIVE BACKING FROM MICROPHONE, ATTACH TO OVERHEAD CONSOLE AND TUCK HARNESS UNDER HEADLINER
 NOTA: FROTE EL ÁREA CON ALCOHOL QUITA LA CUBIERTA PROTECTORA ADHESIVA DEL MICRÓFONO, FIJE A LA CONSOLA DE TECHO Y PLIEGUE EL MAZO BAJO EL FORRO DEL TECHO
 REMARQUE : NETTOYER LE SITE DE MONTAGE AVEC UN TAMPON À L'ALCOOL. RETIRER LA PROTECTION DU MICROPHONE ET FIXER CE DERNIER SUR LA CONSOLA DE PLAFOND ET PASSER LES FILS SOUS LA GARNITURE DE TOIT.

7

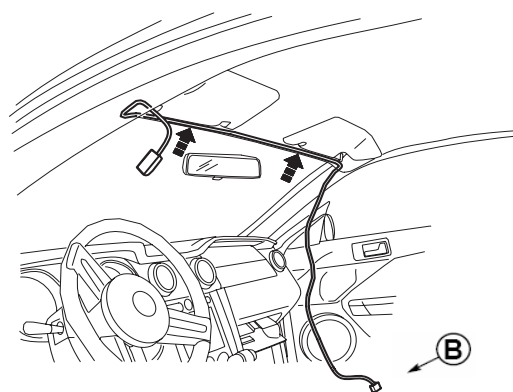

NOTE: MODELS NOT EQUIPPED WITH OVERHEAD CONSOLE
 NOTA: MODELOS NO EQUIPADOS CON CONSOLA DE TECHO
 REMARQUE : MODÈLES NON ÉQUIPÉS D'UNE CONSOLA AU PLAFOND

8

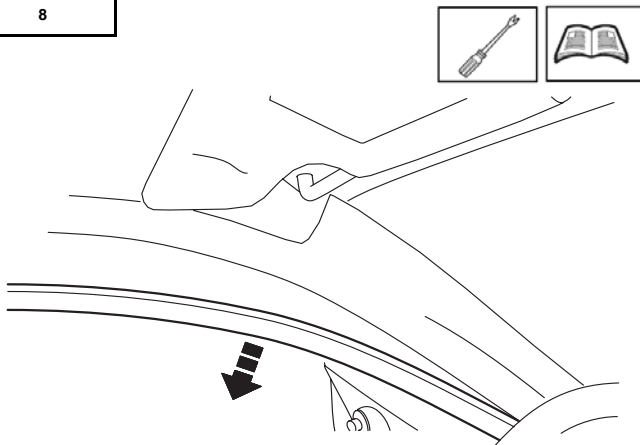

NOTE: MODELS NOT EQUIPPED WITH OVERHEAD CONSOLE
 NOTA: MODELOS NO EQUIPADOS CON CONSOLA DE TECHO
 REMARQUE : MODÈLES NON ÉQUIPÉS D'UNE CONSOLA AU PLAFOND
 NOTE: REMOVE WEATHERSTRIP
 NOTA: QUITA LA GOMA SELLADORA
 REMARQUE : RETIRER LE JOINT D'ÉTANCHÉITÉ

9

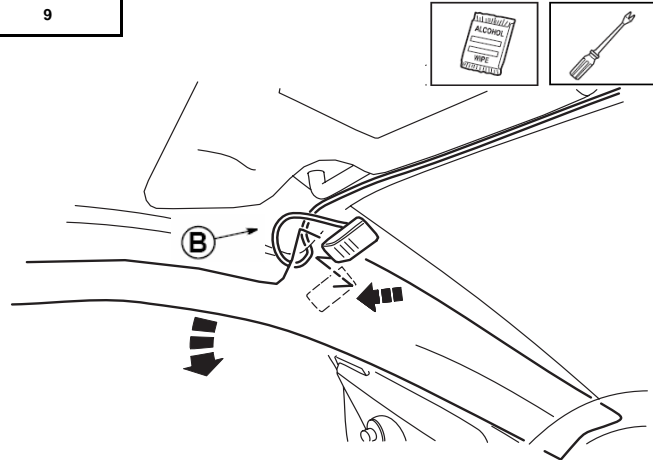

NOTE: MODELS NOT EQUIPPED WITH OVERHEAD CONSOLE
 NOTA: MODELOS NO EQUIPADOS CON CONSOLA DE TECHO
 REMARQUE : MODÈLES NON ÉQUIPÉS D'UNE CONSOLA AU PLAFOND
 NOTE: CLEAN AREA WITH ALCOHOL WIPE REMOVE ADHESIVE BACKING FROM MICROPHONE
 NOTA: FROTE EL ÁREA CON ALCOHOL QUITA LA CUBIERTA PROTECTORA ADHESIVA DEL MICRÓFONO.
 REMARQUE : NETTOYER LE SITE DE MONTAGE AVEC UN TAMPON À L'ALCOOL RETIRER LA PROTECTION DU MICROPHONE.

10

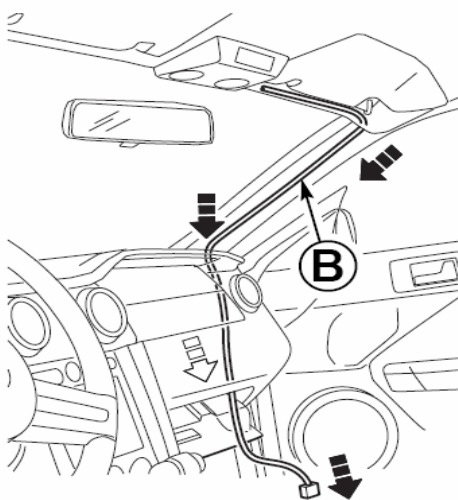

11

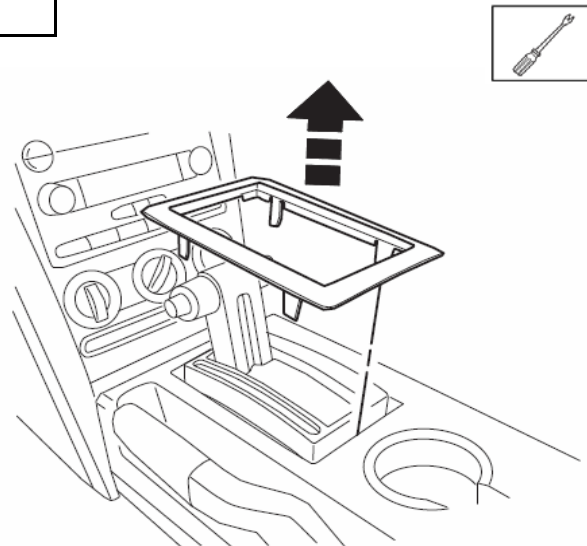

12

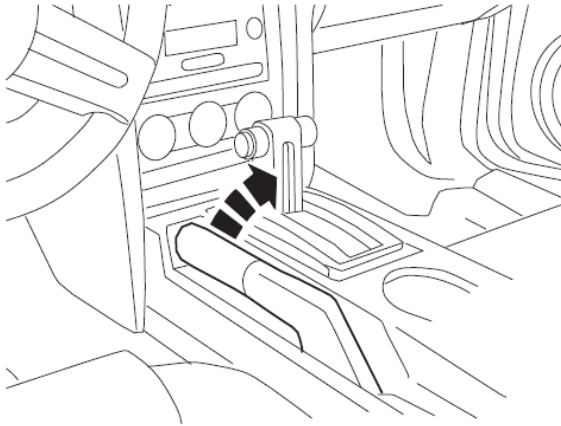

13

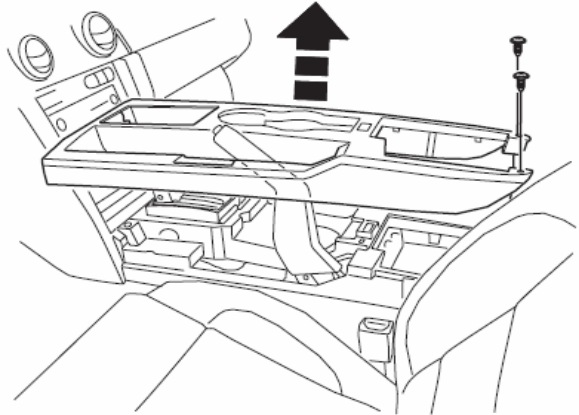
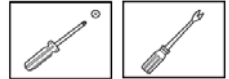

14

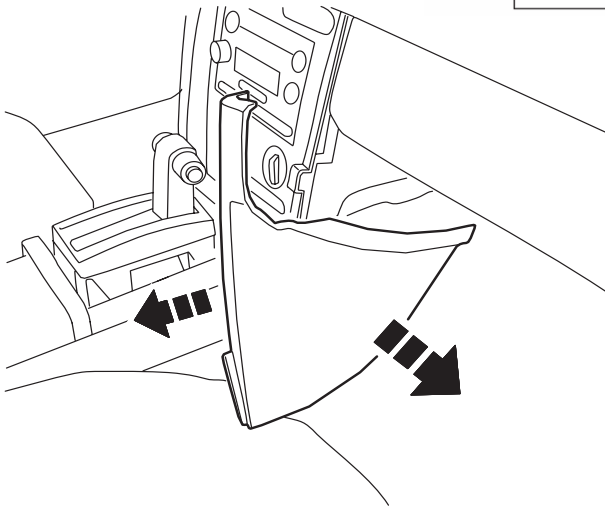
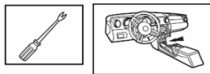

15

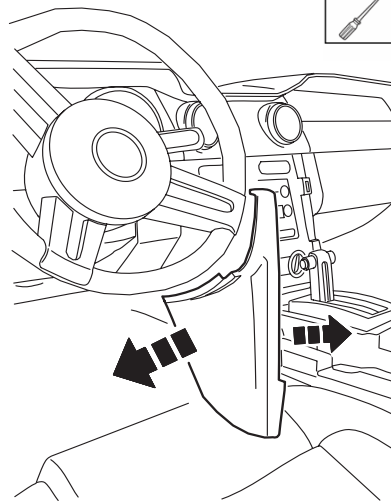
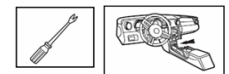

16

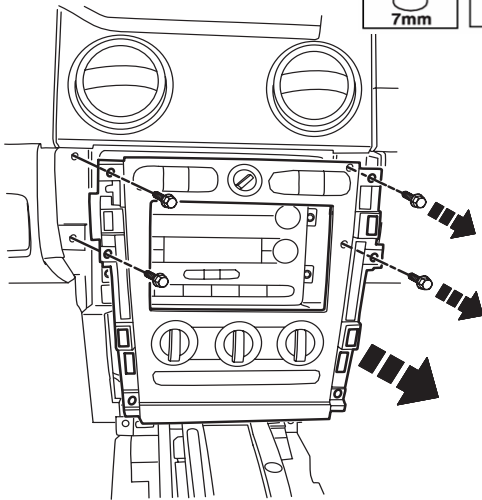

17

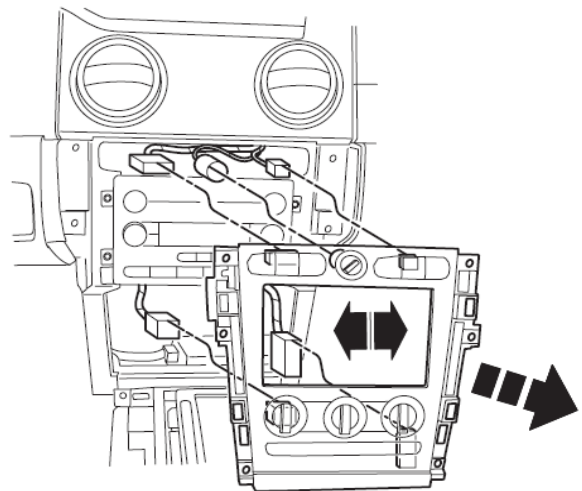

18

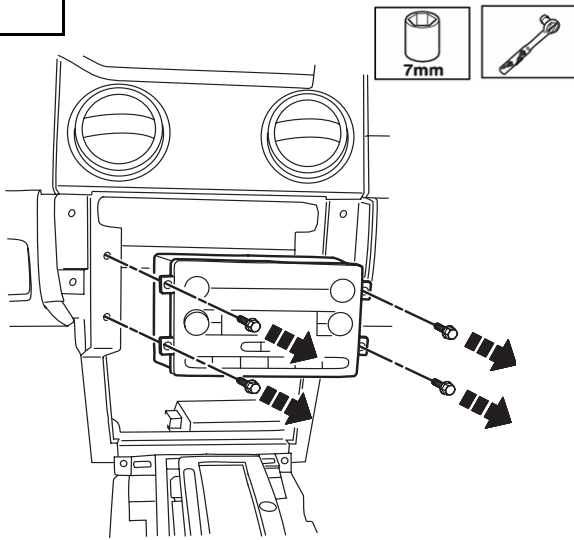

19

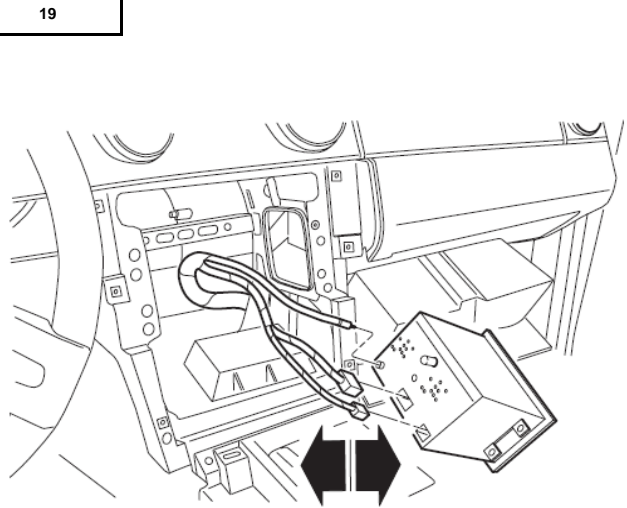

20

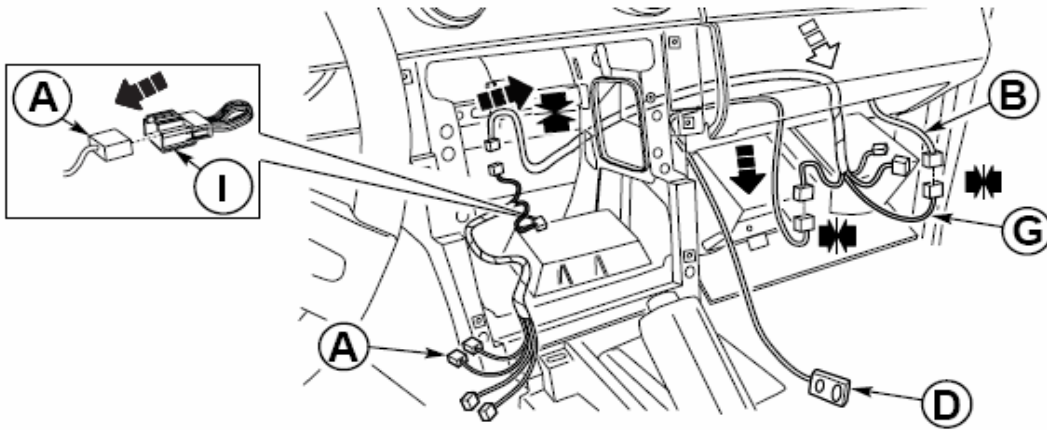

NOTE: MUST INSTALL END CAP ONTO COMMON HARNESS IF TRIP TUNES SYSTEM IS NOT INSTALLED.
 NOTA: DEBE INSTALAR LA TAPA DE EXTREMO SOBRE EL ARNÉS COMÚN SI EL SISTEMA TRIP TUNES NO ESTÁ INSTALADO.
 REMARQUE: LE BOUCHON D'EXTREMITÉ DOIT ÊTRE INSTALLÉ SUR LE FAISCEAU COMMUN SI LE SYSTÈME TRIP TUNES TM N'EST PAS INSTALLÉ.

21

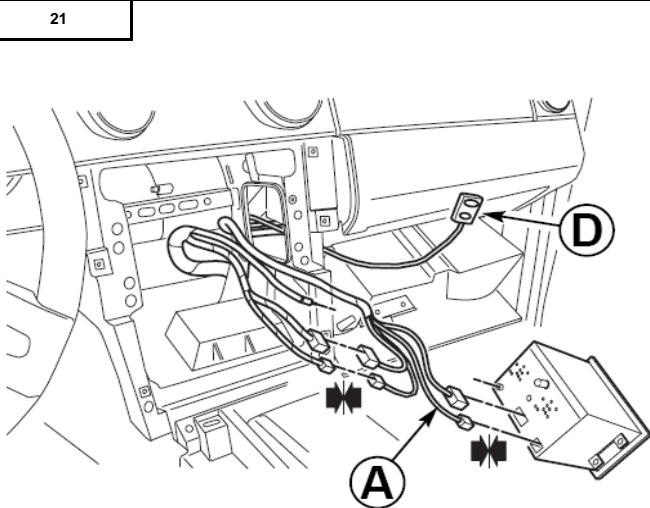

22

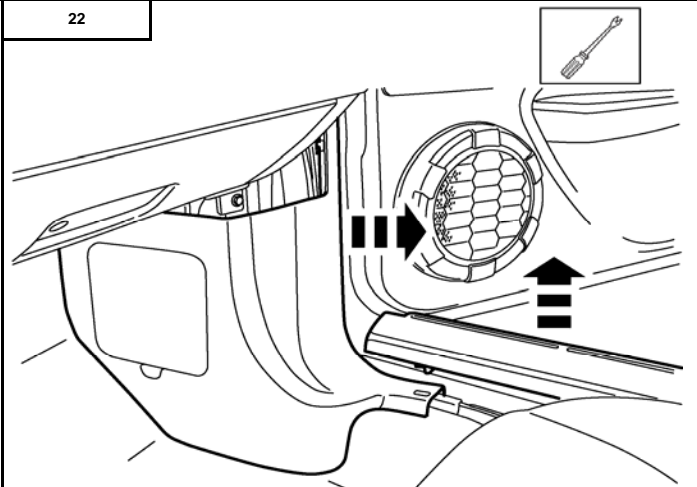

23

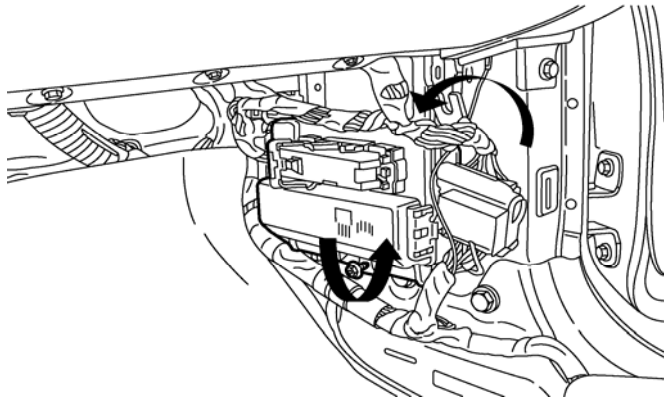

24

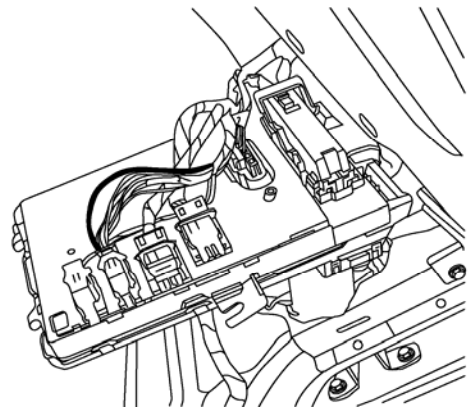

25

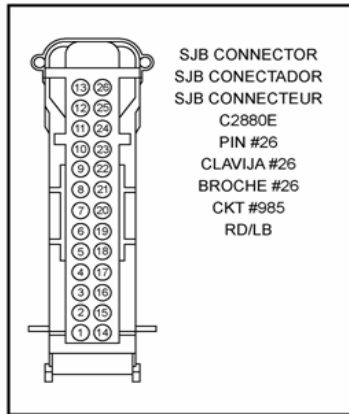

FUSED END OF JUMPER
EXTREMO FUNDIDO DEL PUENTE
EXTREMITÉ FONDUE DE PULLOVER

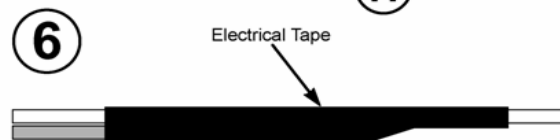
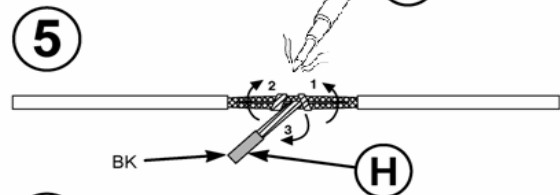
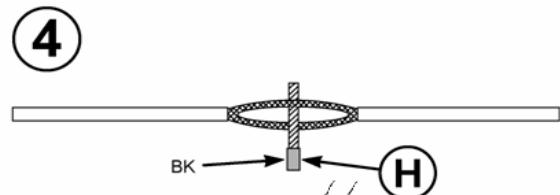
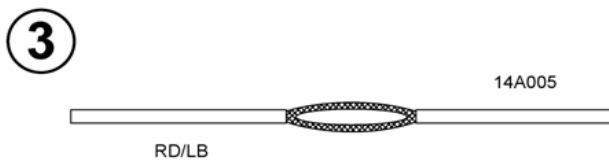
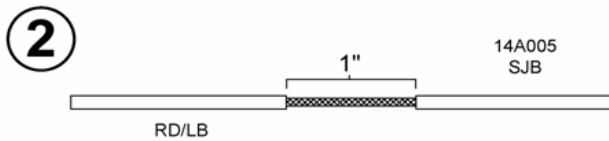
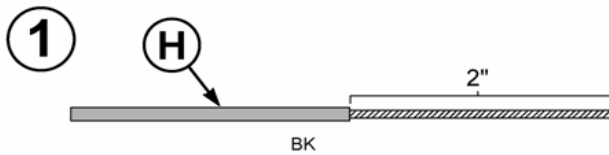
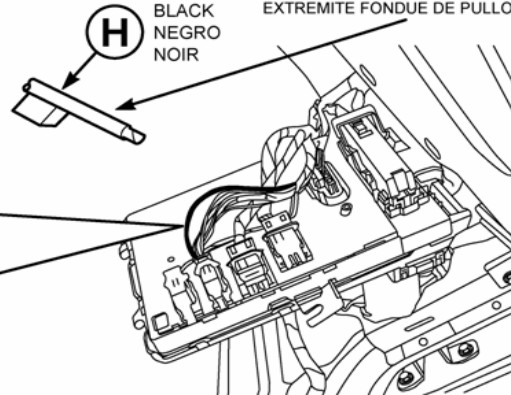

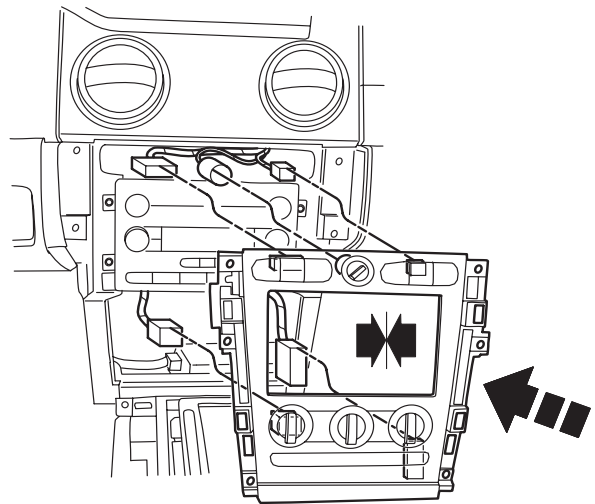
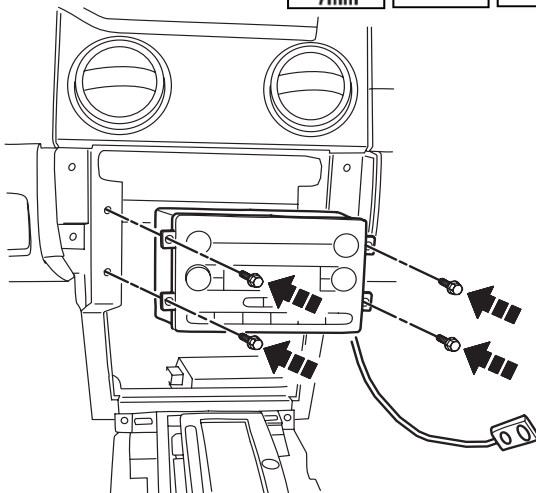
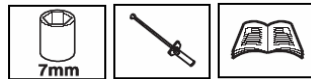
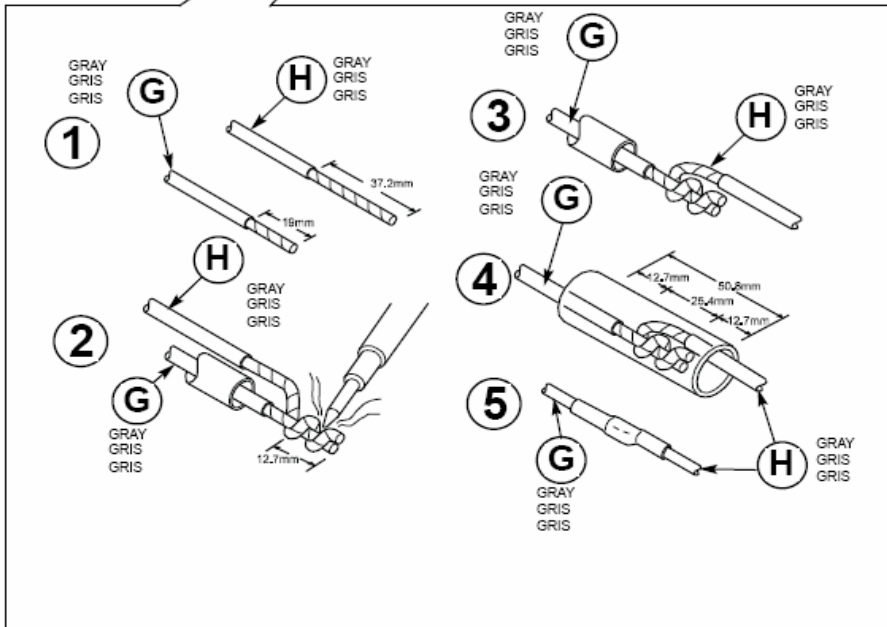
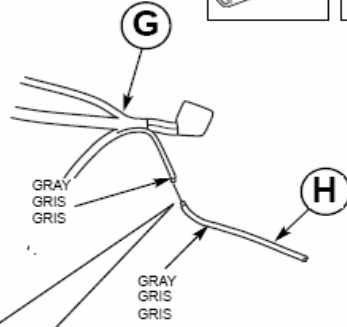

29

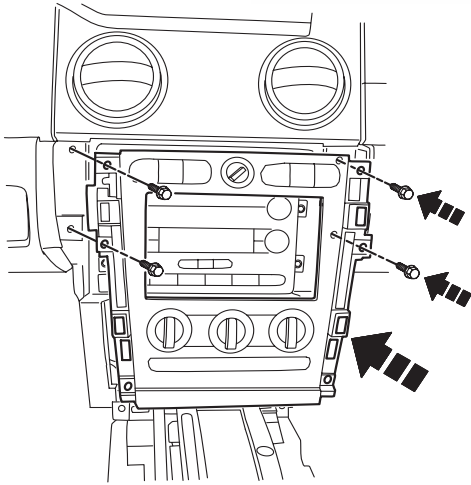
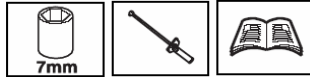

30

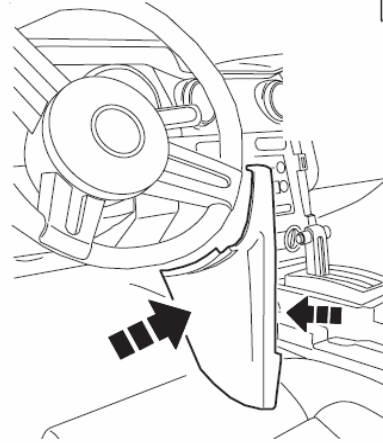
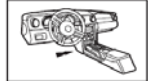

31

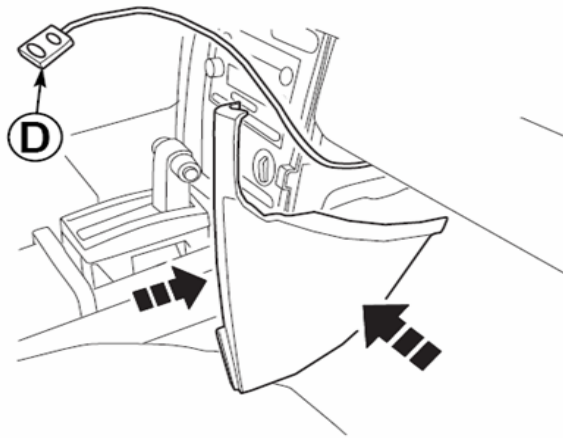
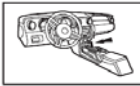

32

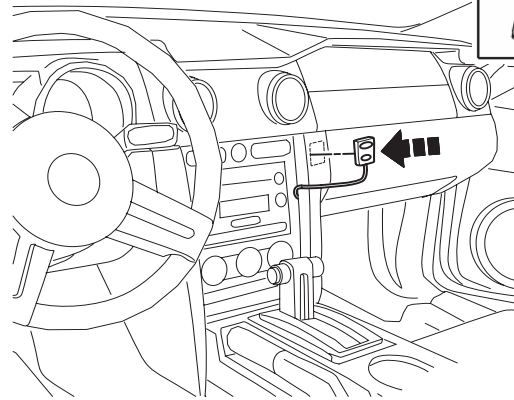

NOTE: CLEAN AREA WITH ALCOHOL WIPE REMOVE ADHESIVE BACKING FROM REAR OF HMI CONTROL AND SECURE UNIT TO BEZEL
 NOTA: FROTE EL ÁREA CON ALCOHOL quite la película protectora adhesiva de la parte trasera del control HMI y fije la unidad al reborde
 REMARQUE : NETTOYER LE SITE DE MONTAGE AVEC UN TAMPON À L'ALCOOL. RETIRER LA PROTECTION D'ADHÉSIF DE LA COMMANDE DE L'IHM ET FIXER SUR L'ENCADREMENT.

33

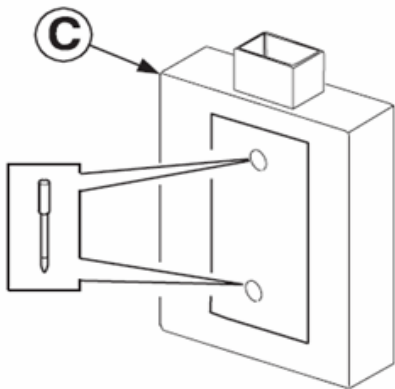

NOTE: USING PUNCH TOOL, PUNCTURE TAPE COVERING HOLES
 NOTA: CON UN PUNZÓN, AHUEQUE LOS ORIFICIOS QUE CUBREN LA CINTA
 REMARQUE : À L'AIDE D'UN POINÇON, PERCER LE RUBAN COUVRANT LES TROUS.

34

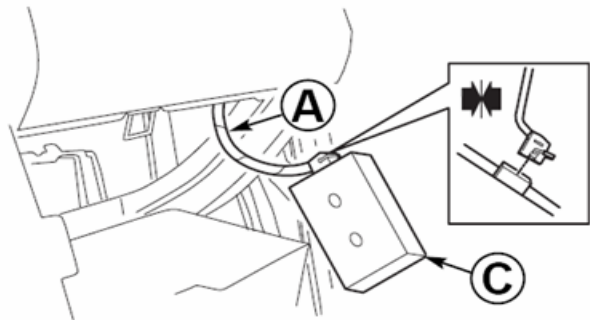

NOTE: PLEASE INSURE THAT LOCKING FRAME IS FACING UP, LABEL FROM ITEM C IS VISIBLE AND ZIP TIE (ITEM F) TO VP MAG BEAM
 NOTA: ASEGÚRESE DE QUE EL BASTIDOR DE BLOQUEO ESTÉ HACIA ARRIBA, EL RÓTULO DEL ELEMENTO C ESTÉ VISIBLE Y HAGA AVANZAR RÁPIDAMENTE LA SUJECIÓN (ELEMENTO F) A LA BARRA DEL PANEL DE INSTRUMENTOS
 REMARQUE : VÉRIFIER QUE LE CADRE DE VERROUILLAGE EST ORIENTÉ VERS LE HAUT, QUE L'AUTOCOLLANT DE L'ARTICLE C EST VISIBLE ET ASSUJETTIR L'ATTACHE (ARTICLE F) SUR LA TRAVERSE DU TABLEAU DE BORD.

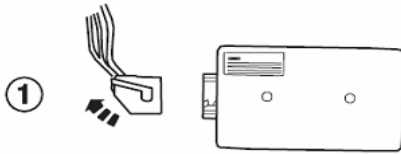

NOTE: PUSH IN TAB FROM ITEM A TO RELEASE LOCKING ARM
 NOTA: HUNDA LA OREJETA DEL ELEMENTO A PARA SOLTAR EL BRAZO DE BLOQUEO
 REMARQUE : APPUYER SUR LA LANGUETTE DE L'ARTICLE A POUR LIBÉRER LE BRAS DE VERROUILLAGE.

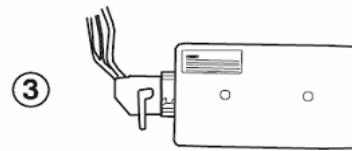

NOTE: INSERT ITEM A INTO ITEM C UNTIL LOCKING ARM TRIES TO RETURN TO ITS ORIGINAL POSITION
 NOTA: INSERTE EL ELEMENTO A EN EL ELEMENTO C HASTA QUE EL BRAZO DE BLOQUEO INTENTE REGRESAR A LA POSICIÓN ORIGINAL
 REMARQUE : INSÉRER L'ARTICLE A DANS L'ARTICLE C, JUSQU'À CE QUE LE BRAS DE VERROUILLAGE ESSAIE DE RETOURNER À SA POSITION D'ORIGINE.

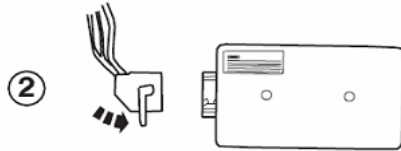

NOTE: ONCE RELEASED, ROTATE LOCKING ARM OF ITEM A 90 DEGREES
 NOTA: UNA VEZ SUELTO, GIRE A 90 GRADOS EL BRAZO DE BLOQUEO DEL ELEMENTO A
 REMARQUE : UNE FOIS LE BRAS DE VERROUILLAGE DE L'ARTICLE A LIBÉRÉ, LE TOURNER DE 90 DEGRÉS.

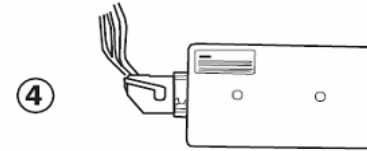

NOTE: CONTINUE PUSHING ITEM A INTO ITEM C UNTIL LOCKING ARM IS IN ITS ORIGINAL POSITION
 NOTA: CONTINUÉ EMPUJANDO EL ELEMENTO A EN EL ELEMENTO C HASTA QUE EL BRAZO DE BLOQUEO ESTÉ EN LA POSICIÓN ORIGINAL
 REMARQUE : CONTINUER DE POUSSER L'ARTICLE A DANS L'ARTICLE C, JUSQU'À CE QUE LE BRAS DE VERROUILLAGE SE TROUVE SUR SA POSITION D'ORIGINE.

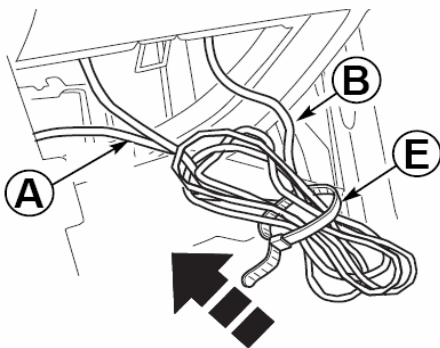
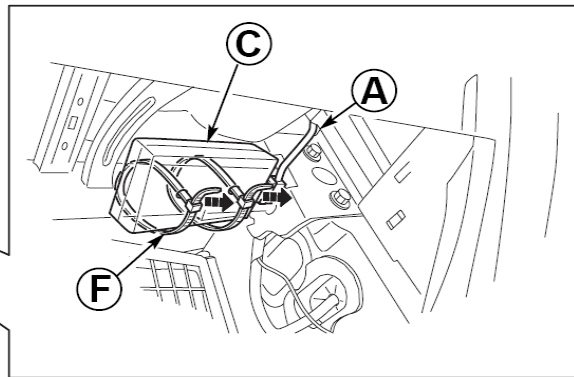
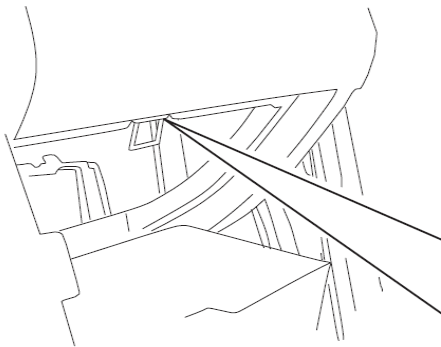

NOTE: ZIP TIE BUNDLE AND PLACE IN GLOVE BOX CAVITY
 NOTA: HAGA AVANZAR RÁPIDAMENTE EL MANOJO DE SUJECIÓN Y COLOQUE EN LA CAVIDAD DE LA GUANTERA
 REMARQUE : SERRER L'ATTACHE DU FAISCEAU ET PLACER CE DERNIER DANS LA CAVITÉ DE LA BOÎTE À GANTS.

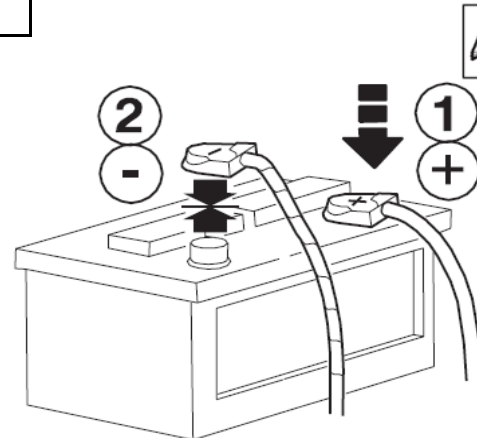

NOTE: REVERSE TRIM INSTALLATION STEPS FOR RE-INSTALLATION

NOTA: INVIERTA LOS PASOS DE LA INSTALACIÓN DE LA GUARNICIÓN PARA VOLVER A INSTALAR

REMARQUE : REPRENDRE LA PROCÉDURE D'INSTALLATION À L'INVERSE POUR LA RÉINSTALLATION

NOTE: TO INSURE PROPER INSTALLATION

AFTER COMPLETING INSTALLATION, TURN ON RADIO, PRESS 3 & 6 BUTTONS AT THE SAME TIME UNTIL THE SELF TEST STARTS, CONFIRM ALL SPEAKERS ARE FUNCTIONING
IF VEHICLE IS EQUIPPED, MAKE SURE STEERING WHEEL AUDIO CONTROLS ARE FUNCTIONING PROPERLY

PRESS VR BUTTON AND MAKE SURE SYSTEM RESPONDS WITH A "READY" PROMPT



SAY "DIAL"
YOU SHOULD RECEIVE A REPLY STATING "PHONE NOT AVAILABLE"

NOTA: PARA ASEGURAR UNA INSTALACIÓN ADECUADA

LUEGO DE COMPLETAR LA INSTALACIÓN, ENCIENDA LA RADIO, PRESIONE LOS BOTONES 3 Y 6 AL MISMO TIEMPO HASTA QUE COMIENZE LA AUTO PRUEBA, CONFIRME QUE FUNCIONAN TODAS LAS BOCINAS
SI EL VEHÍCULO ESTÁ EQUIPADO, ASEGÚRESE QUE LOS CONTROLES DE AUDIO DEL MANUBRIO FUNCIONEN ADECUADAMENTE

PRESIONE EL BOTÓN VR Y ASEGÚRESE DE QUE EL SISTEMA RESPONDA CON LA INDICACIÓN "LISTO" (PREPARADO)



DIGA "MARCAR"
RECIBIRÁ LA RESPUESTA "TELÉFONO NO DISPONIBLE"

REMARQUE : POUR VÉRIFIER QUE L'INSTALLATION EST CORRECTE :

UNE FOIS L'INSTALLATION TERMINÉE, ALLUMER LA RADIO, APPUYER SUR LES TOUCHES 3 ET 6 SIMULTANÉMENT JUSQU'À CE QUE L'AUTOTEST COMMENCE. VÉRIFIER QUE TOUS LES HAUT-PARLEURS FONCTIONNENT.
SI LE VÉHICULE EST ÉQUIPÉ DE COMMANDES AUDIO AU VOLANT, S'ASSURER QU'ELLES FONCTIONNENT CORRECTEMENT.

APPUYER SUR LA TOUCHE RV DU TÉLÉPHONE ET S'ASSURER QUE LE MESSAGE " PRÊT " S'AFFICHE



PRONONCER " COMPOSER ". LA RÉPONSE DEVRAIT ÊTRE : " TÉLÉPHONE PAS DISPONIBLE ".

Congratulations!

You've purchased a Genuine Ford Brand Accessory designed, engineered, and built specifically for your Ford vehicle. We have made every effort to ensure that the Mobile - Ease Hands Free Cell Phone System is top quality in terms of fit, durability, finish and ease of installation.

At Ford Customer Service Division,
customer satisfaction is our number one priority!

¡Felicidades!

Acaba de comprar un Accesorio marca Ford Genuino, diseñado y construido específicamente para su vehículo Ford. Hemos realizado todos los esfuerzos necesarios para que el Juego del Sistema De Telefono Movil Manos Libres sea de la mejor calidad en cuanto a ajuste, durabilidad acabado y facilidad de instalación.

Para la División de Atención al Cliente de Ford,
la satisfacción del cliente es nuestra principal prioridad.

Félicitations !

Vous avez acheté un accessoire Ford d'origine conçu, étudié et fabriqué spécialement pour votre véhicule Ford. Nous avons pris toutes les mesures nécessaires pour assurer que ce système de téléphone cellulaire mains libres Mobile - Ease d'une qualité supérieure en ce qui concerne l'ajustement, la durabilité, la finition et la facilité d'installation.

Pour la division du service à la clientèle Ford, la satisfaction du client a priorité absolue !



Ford Customer Service Division



ACCESSORIZE YOUR VEHICLE AT: WWW.FORDACCESSORIESSTORE.COM

