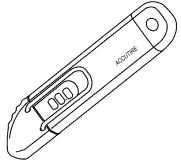
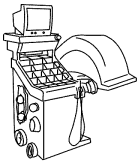

SECTION 204-04 Wheels and Tires

CONTENTS	PAGE
DIAGNOSIS AND TESTING	
Wheels And Tires	204-04-2
Inspection and Verification	204-04-2
Tire Wear	204-04-3
Symptom Chart — Tire Wear	204-04-5
Symptom Chart — NVH	204-04-5
Pinpoint Tests	204-04-5
Component Tests	204-04-7
Radial Runout	204-04-7
Loaded Runout Measurement (Hunter Road Force® 9700 Series Wheel Balancer)	204-04-7
Runout Measurement (Dial Indicator)	204-04-8
Match Mounting	204-04-10
Wheel-to-Hub Optimization	204-04-12

DIAGNOSIS AND TESTING**Wheels And Tires****Special Tool(s)**

 <p>ST2869-A</p>	<p>Digital Tire Gauge 204-354</p>
 <p>ST3058-A</p>	<p>Hunter Road Force® Wheel Balancer GSP9700 Series</p>

Inspection and Verification**WARNING:**

Vehicle may have multiple drive wheels. Do not use engine to power the driveline unless all drive wheels are elevated off the ground. Drive wheels in contact with ground could cause unexpected vehicle movement. Failure to follow this instruction may result in serious personal injury.

Verify the customer concern by carrying out a road test on a smooth road. If any vibrations are apparent, GO to Symptom Chart - NVH.

To maximize tire performance, inspect for signs of incorrect inflation and uneven wear, which may indicate a need for balancing, rotation or front suspension alignment.

Correct tire pressure and driving techniques have an important influence on tire life. Heavy cornering, excessively rapid acceleration and unnecessary sharp braking increase tire wear.

Replacement tires must follow the recommended:

- tire sizes.
- speed rating.
- load range.
- tire construction type.

The use of any other tire/wheel size, load range or type can seriously affect:

- ride.
- handling.
- speedometer/odometer calibration.
- vehicle ground clearance.
- tire clearance between the body and chassis.
- wheel bearing life.
- braking performance.

New wheels need to be installed when the vehicle wheels:

- are bent.
- are cracked.
- are dented.
- are heavily corroded.
- are leaking.
- have elongated wheel hub bolt holes.

DIAGNOSIS AND TESTING (Continued)

- have excessive lateral or radial runout.

It is mandatory to use only the tire sizes recommended on the tire label located on the driver door or door pillar attached to the vehicle. Larger or smaller tires can damage the vehicle, affect durability and require changing the speedometer calibration. Make sure wheel size and offsets match those recommended for the tire in use.

1. Inspect the tires for signs of uneven wear. Refer to the following descriptions to identify the type of wear and GO to Symptom Chart - Tire Wear for the appropriate repair action to be carried out.
2. Check the tires for:
 - cuts.
 - stone bruises.
 - abrasions.
 - blisters.
 - embedded objects.
3. Check the valve stems for:
 - cracks.
 - cuts.

Install a new valve stem when damage is found or anytime a new tire is installed.

4. Tread wear indicators are molded into the bottom of the tread grooves. Install a new tire when the indicator bands become less than 2/32 inch.

Tire Wear

Tire wear is commonly defined as a loss of tread depth. Tire tread wear occurs due to friction with the contact surface (road/pavement). The tread should wear down uniformly all the way around the circumference of the tire and all the way across the tread face. When this does not occur, the tire may have abnormal/incorrect wear.

Normal Tire Wear

Normal tire wear is identified as even wear around and across the tread. Because there are many factors (driving style, road surfaces, type of vehicle, type of tire) that can affect tire wear, there is no absolute mileage expectation for a normal wear condition. A tire is considered worn-out when the tread has worn to the level of the tread-wear indicators.

Abnormal/Incorrect Tire Wear

Abnormal/incorrect tire wear is identified as tire wear that is not even around or across the tread and that creates performance-related issues.

Abnormal/incorrect wear can be caused by numerous factors, some of which include driving style (aggressive, passive), climate (hot, cold), road conditions, vehicle loading and maintenance (correct tire pressure, rotation intervals and balance). It is important to determine the root cause of wear on a vehicle before carrying out repair. Tires exhibiting abnormal/incorrect tire wear may still be serviceable provided that the minimum tread depth is greater than 2/32 inch and the tire is not causing a vehicle performance (noise/vibration) concern.

Some abnormal/incorrect wear patterns look the same all the way around the tread of the tire, other wear patterns are not consistent and can occur in various spots on the tread area. The underlying causes of the 6 wear categories are different. Refer to the following descriptions to identify the type of wear and GO to Symptom Chart - Tire Wear for the appropriate repair action to be carried out.

Inner Edge/Shoulder Wear

Inner edge (or shoulder) wear occurs on the inside edge of the tire and is usually caused by excessive toe out and/or excessive negative camber. If the tread depth of the outer shoulder is at least 50% greater than the tread depth of the inner shoulder, the tire is experiencing inner edge/shoulder wear. To determine whether tires have this type of wear, visually inspect the tires. In some instances, it may be necessary to measure the tread depth of each rib and compare it to that of the shoulder.

NOTE:

RF tire shown, others similar.

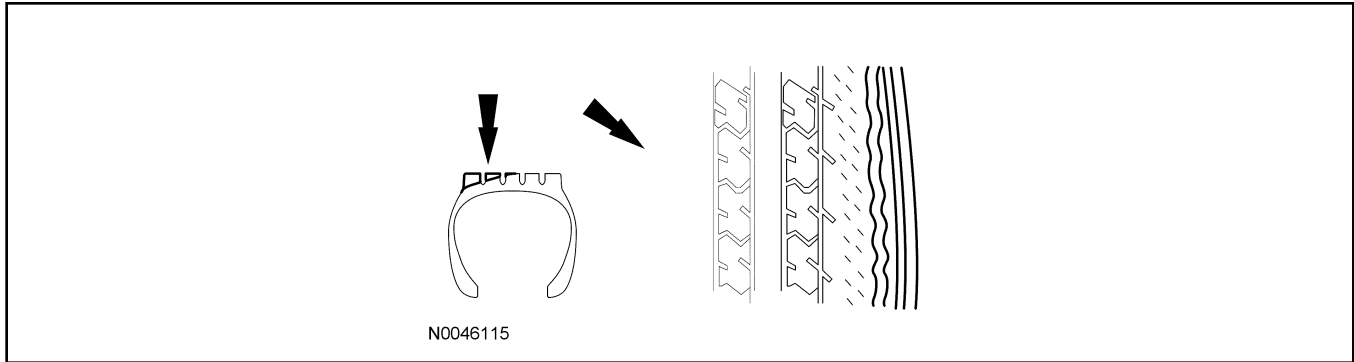
DIAGNOSIS AND TESTING (Continued)**Outer Edge/Shoulder Wear**

Outer edge (or shoulder) wear occurs on the outside edge of the tire and is usually caused by excessive toe in and/or excessive positive camber. If the tread depth of the inner shoulder is at least 50% greater than the tread depth of the outer shoulder, the tire is experiencing outer edge/shoulder wear. To determine whether tires have this type of wear, visually inspect the tires. In some instances, it may be necessary to measure the tread depth of each rib and compare it to that of the shoulder.

NOTE:

RF tire shown, others similar.

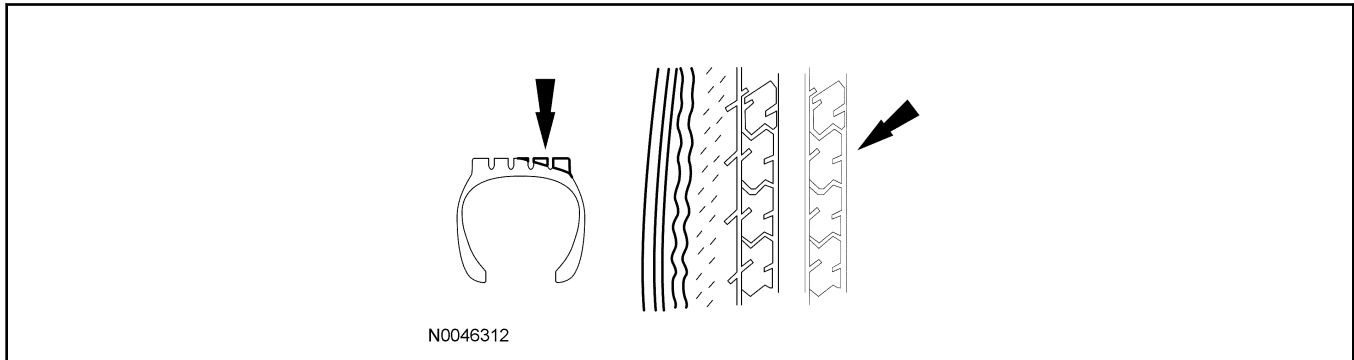
**Heel/Toe Wear**

Heel/toe wear (also known as feathering) occurs along the outside or inside edge/shoulder of the tire. To determine whether tires have this type of wear, visually inspect the tires in both the inside and outside shoulder ribs. In some instances, it may be necessary to measure the difference in tread depth of leading versus trailing edge of each lug in the inside and outside shoulder rib.

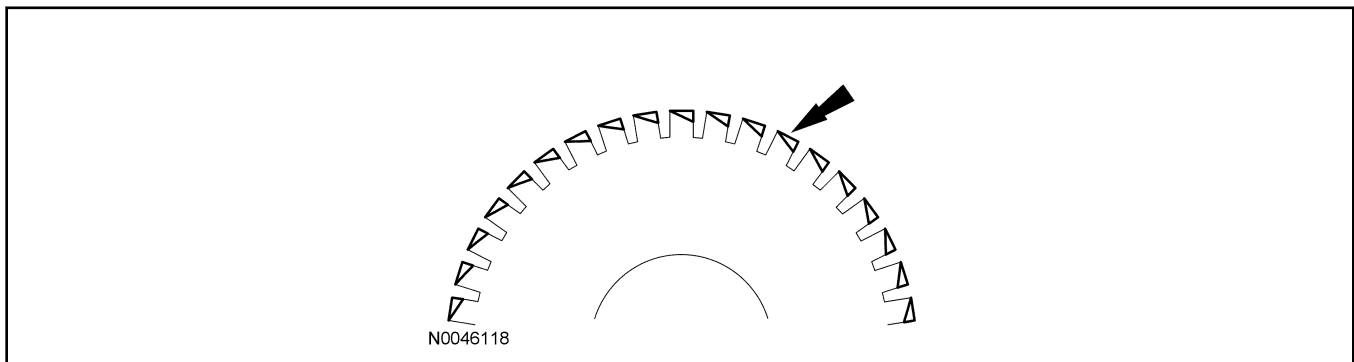
**Diagonal Wear**

Diagonal wear occurs diagonally across the tread area and around the circumference of the tire. To determine whether tires have this type of wear, visually inspect the tires to determine if the wear pattern runs diagonally across the tread and around the circumference of the tire. In some instances, the difference in tread depth along the diagonal wear pattern may need to be measured.

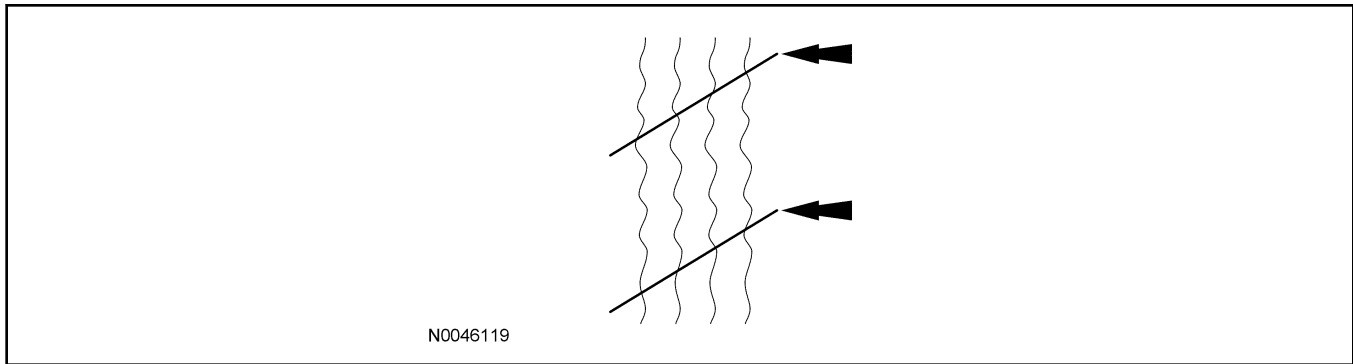
DIAGNOSIS AND TESTING (Continued)**Symptom Chart — Tire Wear****NOTE:**

For suspension system and additional alignment diagnosis, refer to Section 204-00.

Symptom Chart — Tire Wear

Condition	Possible Sources	Action
<ul style="list-style-type: none"> Inner edge/shoulder wear 	<ul style="list-style-type: none"> Excessive toe out and/or negative camber Incorrect wheel and tire assembly rotation intervals High-speed cornering 	<ul style="list-style-type: none"> GO to Pinpoint Test A. GO to Pinpoint Test A. GO to Pinpoint Test A.
<ul style="list-style-type: none"> Outer edge/shoulder wear 	<ul style="list-style-type: none"> Excessive toe in and/or positive camber Incorrect wheel and tire assembly rotation intervals High-speed cornering 	<ul style="list-style-type: none"> GO to Pinpoint Test B. GO to Pinpoint Test B. GO to Pinpoint Test B.
<ul style="list-style-type: none"> Heel/toe wear 	<ul style="list-style-type: none"> Excessive toe in/out Incorrect wheel and tire assembly rotation intervals 	<ul style="list-style-type: none"> ROTATE the wheel and tire assemblies. CHECK the alignment, ADJUST as necessary.
<ul style="list-style-type: none"> Diagonal wear 	<ul style="list-style-type: none"> Excessive toe in/out Incorrect tire rotation intervals Loose, worn or damaged suspension components 	<ul style="list-style-type: none"> GO to Pinpoint Test C. GO to Pinpoint Test C. REFER to Section 204-00.

Symptom Chart — NVH**NOTE:**

NVH symptoms should be identified using the diagnostic tools that are available. For a list of these tools, an explanation of their uses and a glossary of common terms, refer to Section 100-04. Since it is possible any one of multiple systems may be the cause of a symptom, it may be necessary to use a process of elimination type of diagnostic approach to pinpoint the responsible system. If this is not the causal system for the symptom, refer back to Section 100-04 for the next likely system and continue diagnosis.

Symptom Chart — NVH

Condition	Possible Sources	Action
<ul style="list-style-type: none"> Wobble or shimmy 	<ul style="list-style-type: none"> Bent wheel Damaged tire Loose wheel nuts 	<ul style="list-style-type: none"> INSTALL a new wheel as necessary. INSTALL a new tire as necessary. TIGHTEN to specification.
<ul style="list-style-type: none"> High-speed shake 	<ul style="list-style-type: none"> Tires/wheels 	<ul style="list-style-type: none"> REFER to Wheel and Tire Runout Component Tests in this section.
<ul style="list-style-type: none"> Vehicle vibration 	<ul style="list-style-type: none"> Tires/wheels 	<ul style="list-style-type: none"> REFER to Wheel and Tire Runout Component Tests in this section.

Pinpoint Tests

For a description of the various tire wear patterns, refer to Inspection and Verification.

DIAGNOSIS AND TESTING (Continued)**Pinpoint Test A: Inner Edge/Shoulder Wear**

This pinpoint test is intended to diagnose the following:

- Excessive toe out
- Incorrect wheel and tire rotation

PINPOINT TEST A: INNER EDGE/SHOULDER WEAR

Test Step		Result / Action to Take
A1	MEASURE THE TREAD DEPTH	
	<ul style="list-style-type: none"> • Using a tread depth gauge or similar tool, measure the inside edge/shoulder tread depth. • Is the tread depth greater than 2/32 inch? 	<p>Yes ROTATE the wheel and tire assemblies. CHECK and ADJUST the toe to nominal +0.15 degrees (toe in). CHECK and ADJUST caster and camber to nominal. REFER to Section 204-00.</p> <p>No INSTALL a new tire(s). CHECK and ADJUST the toe to nominal. CHECK and ADJUST caster and camber to nominal. REFER to Section 204-00.</p>

Pinpoint Test B: Outer Edge/Shoulder Wear

This pinpoint test is intended to diagnose the following:

- Excessive toe in
- Incorrect wheel and tire rotation

PINPOINT TEST B: OUTER EDGE/SHOULDER WEAR

Test Step		Result / Action to Take
B1	MEASURE THE TREAD DEPTH	
	<ul style="list-style-type: none"> • Using a tread depth gauge or similar tool, measure the outside edge/shoulder tread depth. • Is the tread depth greater than 2/32 inch? 	<p>Yes ROTATE the wheel and tire assemblies. CHECK and ADJUST the toe to nominal -0.15 degrees (toe out). CHECK and ADJUST caster and camber to nominal. REFER to Section 204-00.</p> <p>No INSTALL a new tire(s). CHECK and ADJUST the toe to nominal. CHECK and ADJUST caster and camber to nominal. REFER to Section 204-00.</p>

Pinpoint Test C: Diagonal Wear

This pinpoint test is intended to diagnose the following:

- Incorrect wheel and tire rotation
- Excessive toe in/out
- Incorrect tire inflation
- Loose, worn or damaged suspension components

PINPOINT TEST C: DIAGONAL WEAR

Test Step		Result / Action to Take
C1	MEASURE THE TREAD DEPTH	
	<ul style="list-style-type: none"> • Using a tread depth gauge or similar tool, measure the tread depth of the wear pattern. • Is the tread depth greater than 2/32 inch? 	<p>Yes If no performance concerns (noise/vibration) are present, the tire can remain in service. CHECK the air pressure in the tires, ADJUST as necessary. ROTATE the wheel and tire assemblies. INSPECT for loose, worn or damaged suspension components. INSTALL new components as necessary. CHECK the alignment and ADJUST as necessary. REFER to Section 204-00.</p>

DIAGNOSIS AND TESTING (Continued)

PINPOINT TEST C: DIAGONAL WEAR (Continued)

Test Step		Result / Action to Take
C1	MEASURE THE TREAD DEPTH (Continued)	
		No INSTALL a new tire(s). CHECK the air pressure in the tires, ADJUST as necessary. ROTATE the wheel and tire assemblies. INSPECT for loose, worn or damaged suspension components. INSTALL new components as necessary. CHECK the alignment and ADJUST as necessary. REFER to Section 204-00.

Component Tests

Radial Runout

Radial runout is the egg-shaped deviation from a perfect circle and is measured perpendicular to the circumference. On a wheel and tire assembly, this means measuring the center tire tread rib. The center rib is indicative of the condition of the tire as a whole. Total runout is the difference between the maximum-to-minimum gauge reading. The high spot is the location of maximum runout.

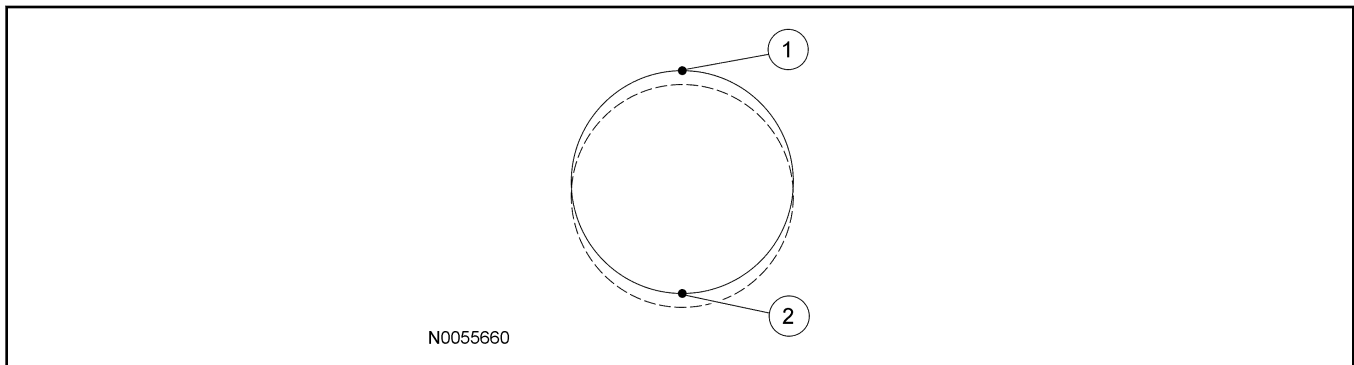

Item	Description
1	High spot
2	Low spot

Loaded Runout Measurement (Hunter Road Force® 9700 Series Wheel Balancer)

NOTE:

Diagnosis of tire/wheel vibration should not be performed on tires with less than 320 km (200 mi). Some initial tire/wheel vibration issues (such as flat spotting) may correct themselves after the tires have been in service for 320 km (200 mi).

This procedure is intended to assist with the diagnosis of wheel and tire assembly runout and/or force variation issues.

The Hunter Road Force® 9700 Series Wheel Balancer measures the wheel and tire assembly's loaded runout and the tire's radial spring rate. The balancer then converts the runout into pounds of force (termed as Road Force®). Measuring loaded runout (Road Force®) is more effective than measuring unloaded runout using a dial indicator.

1. Using a tire crayon, record the vehicle position on the inward sidewall of all 4 tires.

2. Remove the wheel and tire assemblies. Refer to Wheel and Tire in this section.

3. NOTE:

Use only the Digital Tire Gauge any time tire pressures are measured to be sure that accurate values are obtained.

Make sure that the tire pressures are set to the correct pressure as indicated on the Vehicle Certification (VC) label.

4. NOTICE:

Make sure that the correct wheel balancer adapters are used when mounting the assembly to the wheel balancer or damage to the wheel may occur.

NOTE:

Make sure that the wheel and tire assembly is clean and free of foreign material prior to installation on the balancer.

NOTE:

DIAGNOSIS AND TESTING (Continued)

The wheel balancer inflation station must be turned OFF for tires with inflation pressures of 414 kPa (60 psi) or above.

Mount the wheel and tire assembly on a suitable wheel balancer using the correct wheel balancer adapters as shown. Refer to the list of recommended wheel balancer adapters on the PTS website.

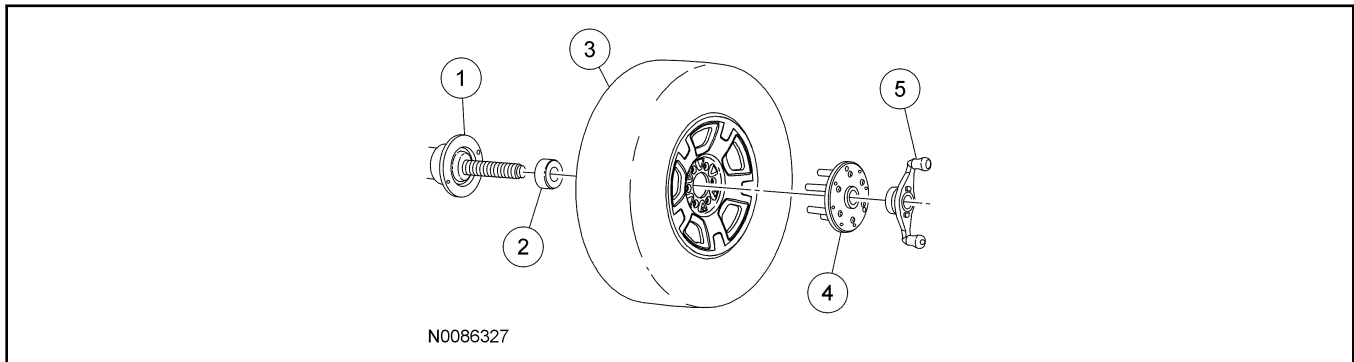

Item	Description
1	Wheel balancer
2	Cone
3	Wheel and tire assembly
4	Finger plate
5	Balancer wing nut

5. Measure the Road Force®.
 - Temporarily mark the high spot and the Road Force® value on the sidewall of the tire. If the wheel and tire assembly Road Force® value is greater than 9 kg (20 lb), carry out the Match Mounting procedure to optimize the wheel and tire assembly.
 - If the wheel and tire assembly Road Force® value is 9 kg (20 lb) or less, permanently mark the high spot and the Road Force® value on the inward sidewall of the tire for reference during future wheel and tire service. Balance the assembly and install the wheel and tire on the vehicle using the Wheel-to-Hub Optimization procedure.

Runout Measurement (Dial Indicator)**NOTE:**

Diagnosis of tire/wheel vibration should not be performed on tires with less than 320 km (200 mi). Some initial tire/wheel vibration issues (such as flat spotting) will correct themselves after the tires have been in service for 320 km (200 mi).

NOTE:

Loaded run-out measurements are the preferred method for verifying tire serviceability. While a dial indicator can be used to optimize the position of the tire on the wheel, the unloaded run-out measurement cannot accurately determine if the tire should be removed from service.

The following procedures should be used if normal diagnostics leads to a potential runout issue.

Some vehicles may exhibit a wheel and tire vibration caused by excessive runout. Radial runout measurements can be taken using a dial indicator and should be measured with the wheel and tire assembly mounted on a suitable wheel balancer. The dial indicator should be mounted securely to eliminate gauge movement when measuring runout.

1. **NOTE:**
Use only the Digital Tire Gauge any time tire pressures are measured to be sure that accurate values are obtained.

Make sure that the tire pressures are set to the correct pressure as indicated on the VC label.
2. Using a tire crayon, record the vehicle position on the inward sidewall of all 4 tires.
3. Remove the wheel and tire assemblies. Refer to Wheel and Tire in this section.
4. **NOTICE:**
Make sure that the correct wheel balancer adapters are used when mounting the assembly to the wheel balancer or damage to the wheel may occur.

NOTE:

Make sure that the wheel and tire assembly is clean and free of foreign material prior to installation on the balancer.

DIAGNOSIS AND TESTING (Continued)

Mount the wheel and tire assembly on a suitable wheel balancer using the correct wheel balancer adapters as shown. Refer to the list of recommended wheel balancer adapters on the PTS website.

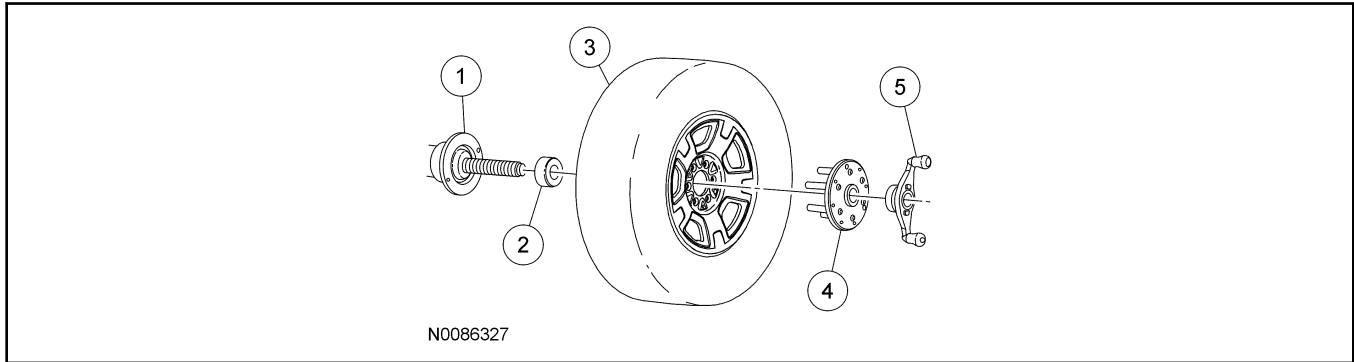

Item	Description
1	Wheel balancer
2	Cone
3	Wheel and tire assembly
4	Finger plate
5	Balancer wing nut

5. **NOTE:**
 Masking tape can be applied on the center tread rib to allow for a smoother measuring surface. Some fluctuation of the gauge reading is expected. Observe the overall sweep of the gauge from the highest to the lowest spot on the tire.
- Position a suitable dial indicator and stand with the dial indicator on the center tread rib.
- Rotate the wheel and tire assembly (or wheel) to locate the low spot.
 - Adjust the runout gauge to read 0.
 - Rotate the wheel and tire assembly one complete revolution to make sure that the low spot has been found and that the dial indicator returns to a 0 reading.

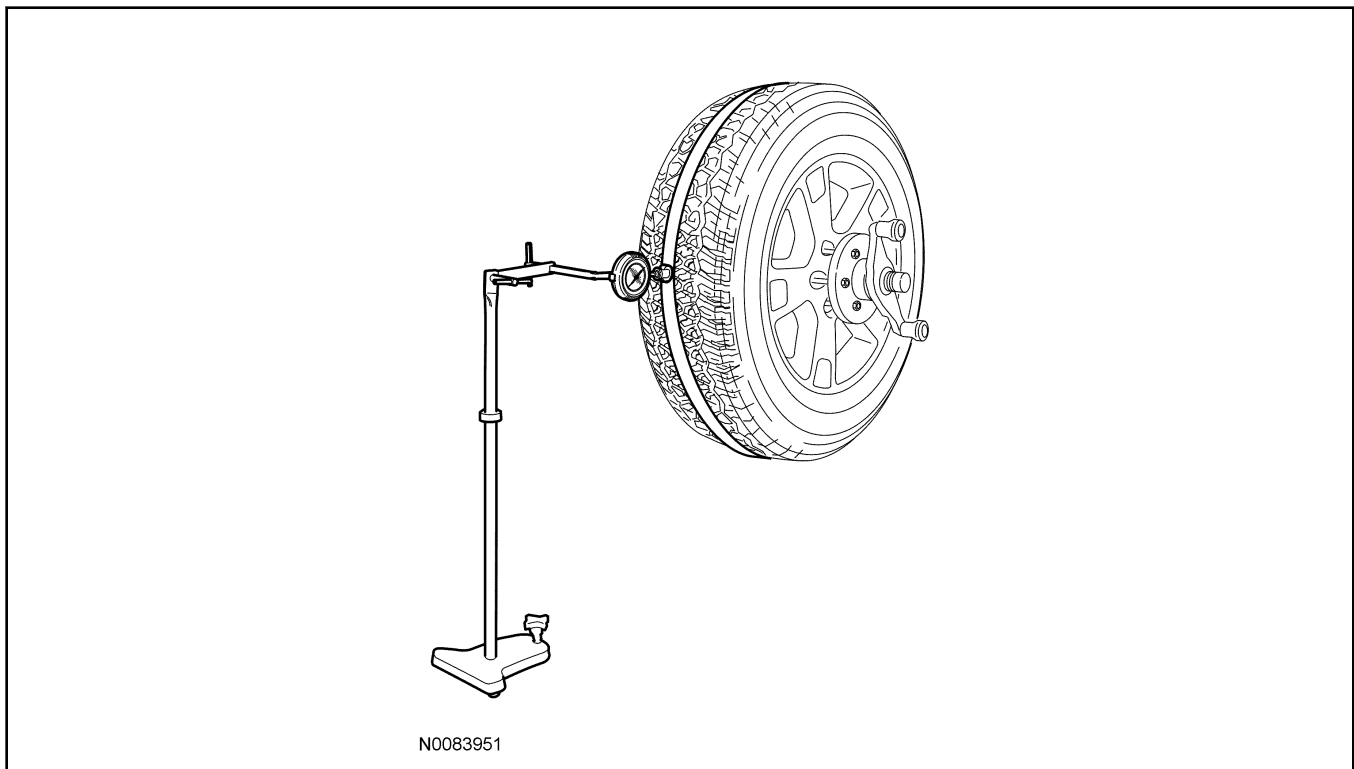

DIAGNOSIS AND TESTING (Continued)

6. While slowly and constantly rotating the wheel and tire assembly (or wheel), measure the radial runout.
 - Note the variance (runout) from 0 on the dial of the gauge.
 - If the runout reading of a wheel and tire assembly is greater than 1.14 mm (0.045 in), locate and temporarily mark the high spot and runout reading on the sidewall of the tire and carry out the Match Mounting procedure to optimize the wheel and tire assembly.
 - If the runout reading of a wheel and tire assembly is 1.14 mm (0.045 in) or less, permanently mark the high spot and the runout reading on the inward sidewall of the tire for reference during future wheel and tire service. Balance the assembly and install the wheel and tire on the vehicle using the Wheel-to-Hub Optimization procedure.

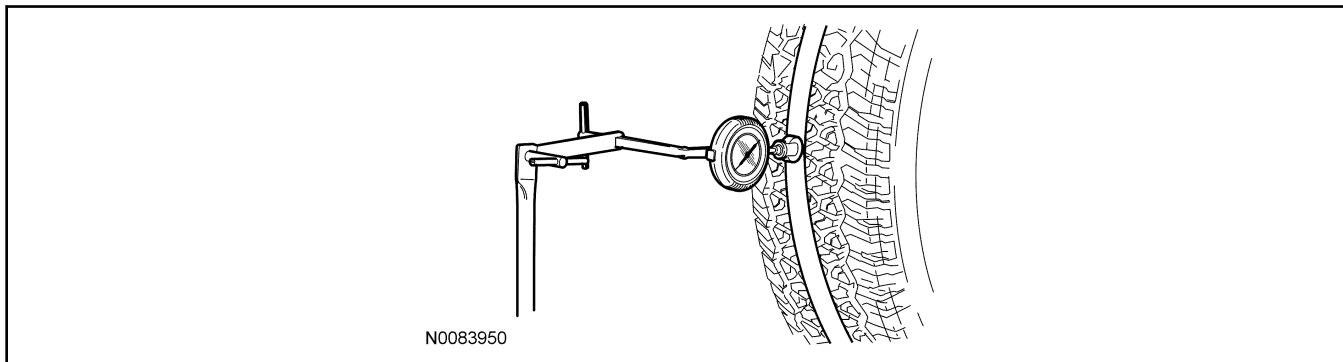
**Match Mounting****NOTE:**

Road Force® values in illustrations are shown in pounds.

Match mounting is a technique used to reduce radial runout or road force on wheel and tire assemblies. Excessive runout is a source of ride quality complaints and match mounting can be used to minimize the runout. Match mounting can be accomplished by changing the position of the tire on the wheel.

1. Position the wheel and tire assembly on a tire machine and put a reference mark on the tire sidewall at the valve stem position.

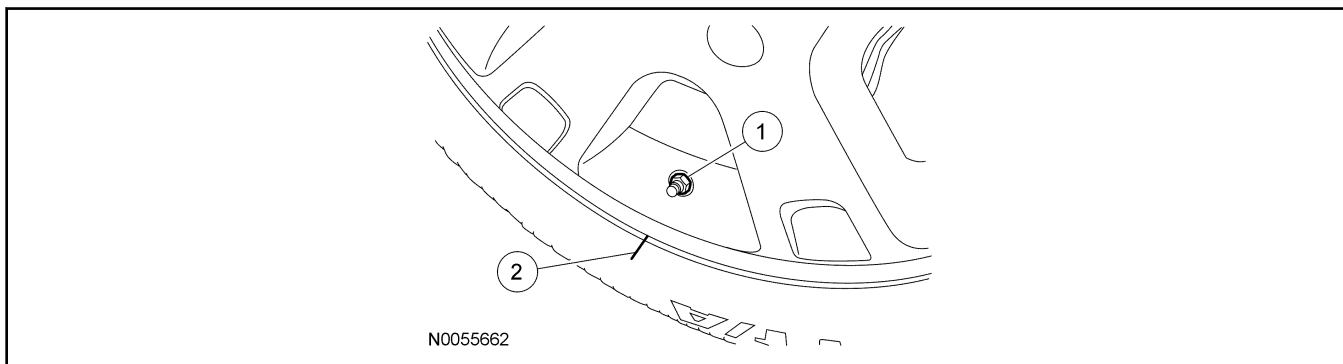

Item	Description
1	Valve stem
2	Reference mark

2. **NOTICE:**
For vehicles equipped with a Tire Pressure Monitoring System (TPMS), the sensor may be damaged by incorrect tire mounting or dismounting. Dismount the tire from the wheel as instructed in the Disassembly and Assembly procedure. Failure to follow these instructions may result in TPMS component damage.

NOTE:

Always make sure that the final high spot and measurement values are permanently marked on the inward sidewall of the tire for reference during future wheel and tire service.

Using a suitable tire machine, separate the tire beads from the wheel.

- Lubricate the tire beads using a suitable fast drying, corrosion inhibiting tire bead lubricant.
- Position the tire 180 degrees (half-way around) on the rim so the valve stem reference mark is now opposite the valve stem.

DIAGNOSIS AND TESTING (Continued)

3. Re-inflate the wheel and tire assembly to the specified air pressure and measure the assembly again using a suitable dial indicator or Hunter Road Force® 9700 Series Wheel Balancer. Mark the second high spot on the tire.
 - If the runout or Road Force® is reduced to within specifications, the concern has been resolved. Balance the assembly and install on the vehicle using the Wheel-to-Hub Optimization procedure.
4. If the second runout or Road Force® measurement is still not within specification and both high spots are close to each other (within 101.6 mm [4 in]), the root cause is probably the tire (the high spot followed the tire).
 - To be **SURE** that the tire is causing the high runout, it is necessary to have 2 runout or Road Force® measurements that are not within specification and the high spots must be in approximately the same location on the tire's sidewall. If the tire is the cause, install a new tire, balance the assembly and install on the vehicle using the Wheel-to-Hub Optimization procedure.
 - If the second high spot is not within 101.6 mm (4 in) of the first high spot, proceed to the next step.

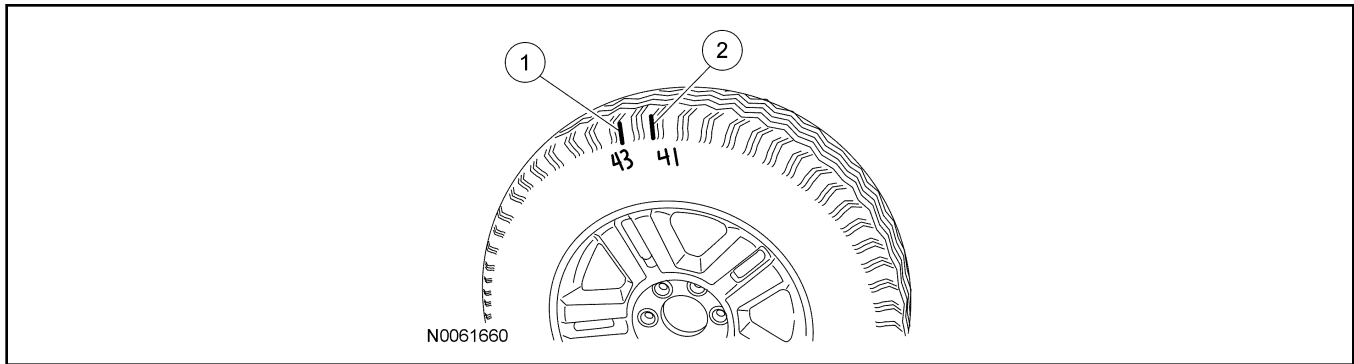

Item	Description
1	First high spot on the tire
2	Second high spot on the tire

5. If the second high spot is still above specification and is within 101.6 mm (4 in) of being opposite the first high spot on the wheel, the root cause is probably the wheel (the high spot followed the wheel). Dismount the tire from the wheel, mount the wheel on a balancer and check the wheel runout. If the wheel runout exceeds 1.14 mm (0.045 in), install a new wheel, balance the assembly and install on the vehicle using the Wheel-to-Hub Optimization procedure.

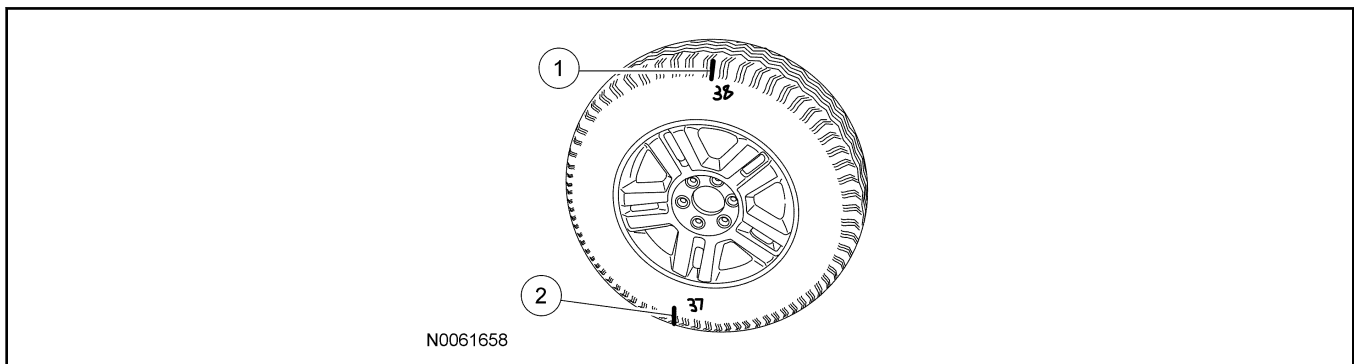

Item	Description
1	First high spot on the tire
2	Second high spot on the tire

6. **NOTE:**
If the second high spot did not follow the wheel or the tire and the runout is still not within specification, improvements may be made by rotating the tire 90 degrees (one-fourth turn).

Draw an arrow on the tire sidewall from the second high spot towards the first high spot (in the shortest direction).

- Separate the tire beads from the wheel and rotate the tire 90 degrees (one-fourth turn) in the direction of the arrow.

DIAGNOSIS AND TESTING (Continued)

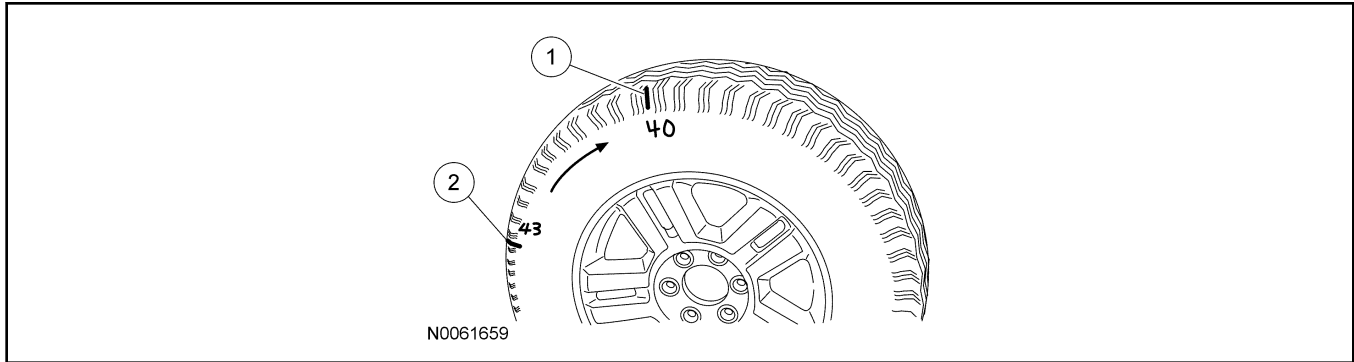

Item	Description
1	First high spot on the tire
2	Second high spot on the tire

Wheel-to-Hub Optimization

Wheel-to-hub optimization is important. Clearance between the wheel and hub can be used to offset or neutralize the Road Force® or run-out of the wheel and tire assembly. For every 0.001 inch of wheel-to-hub clearance, the Road Force® can be affected between 1 and 3 pounds depending on the tire stiffness.

NOTE:

The example below illustrates how the clearance between the wheel and the hub can be used to offset the high spot of radial run-out or Road Force®. Following the procedure will make sure of the best optimization.

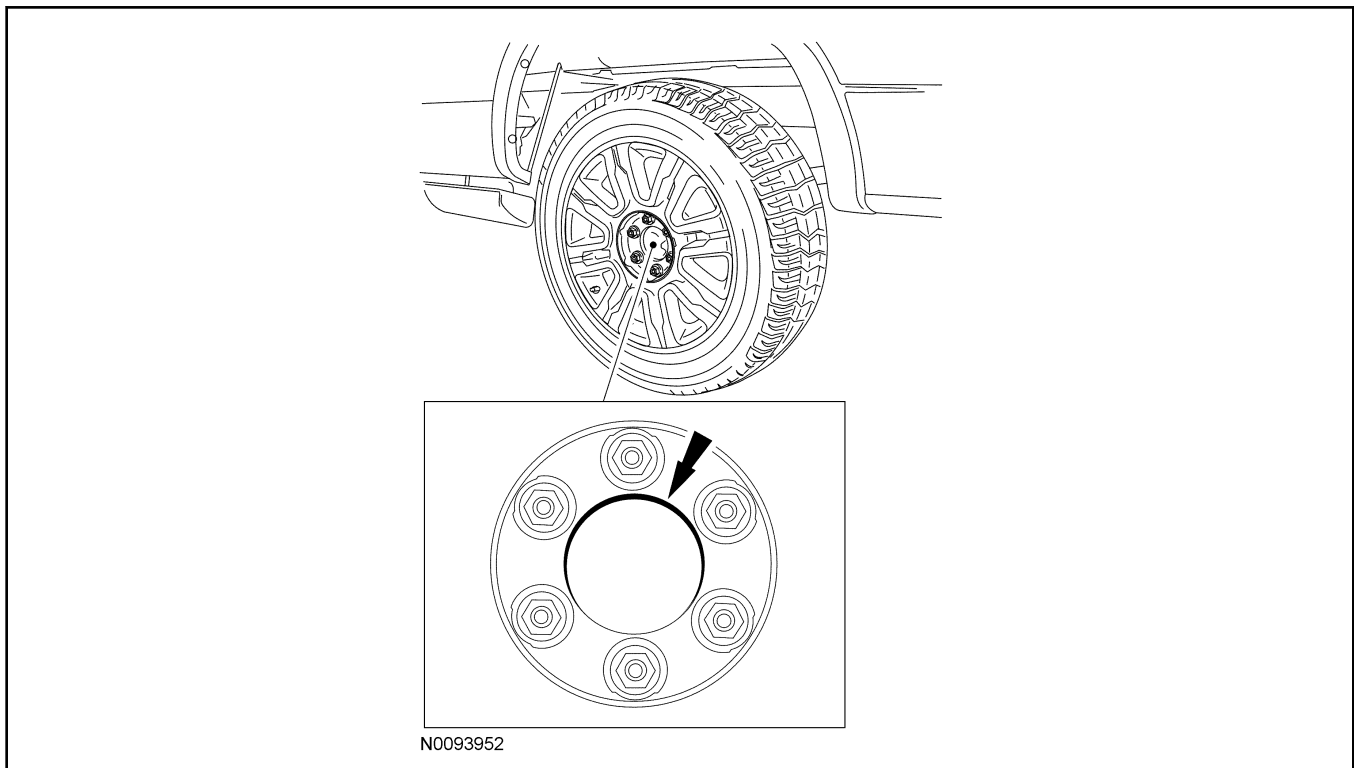

1. Position the wheel and tire assembly on the vehicle so that the high spot location of radial run-out or Road Force® is at the 6 o'clock position and install the wheel nuts by hand until snug.

NOTE:

Do not allow the full weight of the vehicle to rest on the tires while tightening the wheel nuts.

Lower the vehicle until the tires make contact with the ground, slightly loading the suspension. Tighten the wheel nuts as described in Wheel and Tire in this section.