

REMOVAL AND INSTALLATION

Clutch Disc and Pressure Plate — 4.6L

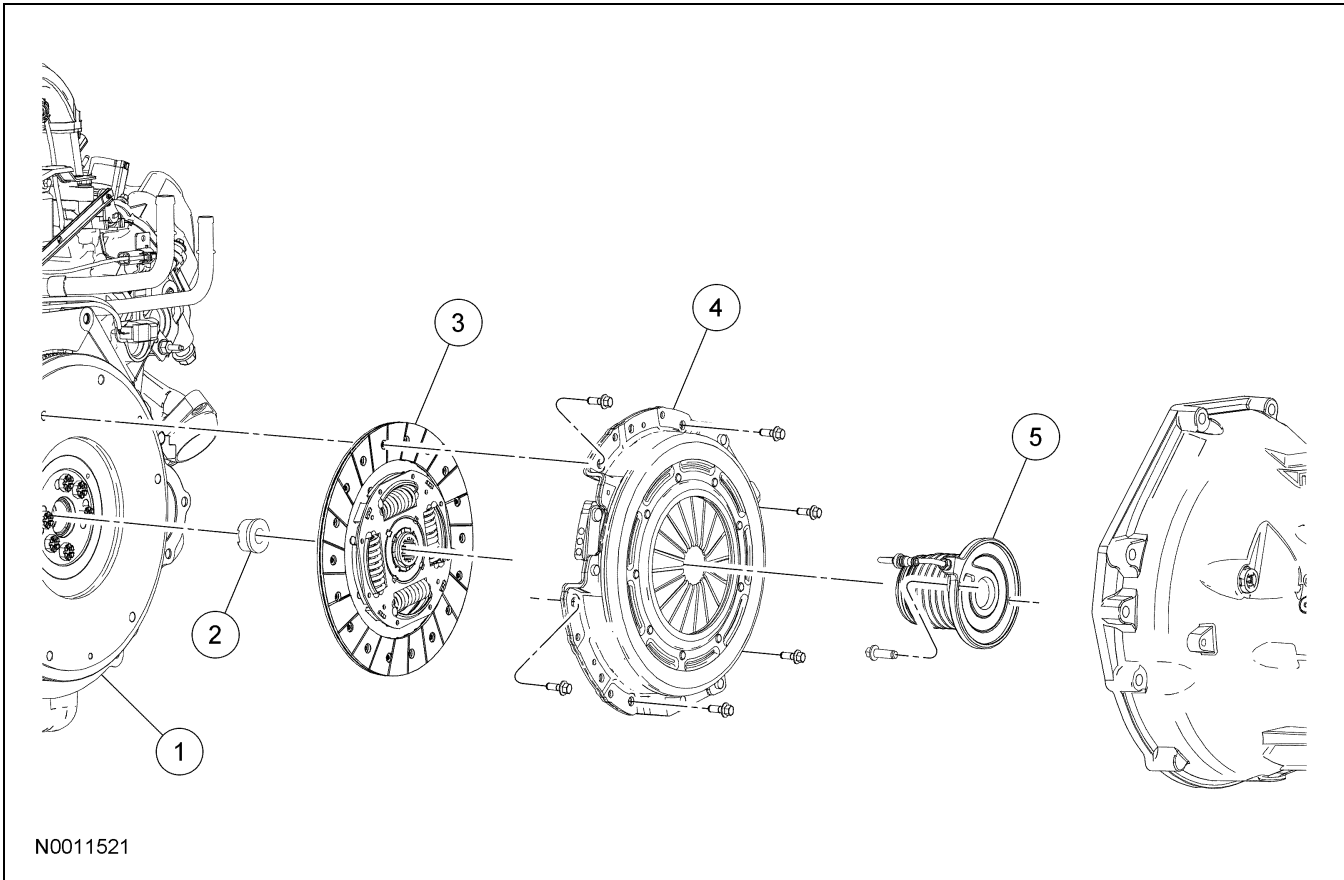

Item	Part Number	Description
1	6375	Flywheel
2	7600	Pilot bearing
3	7550	Clutch disc
4	7563	Pressure plate
5	7A508	Clutch release bearing/slave cylinder

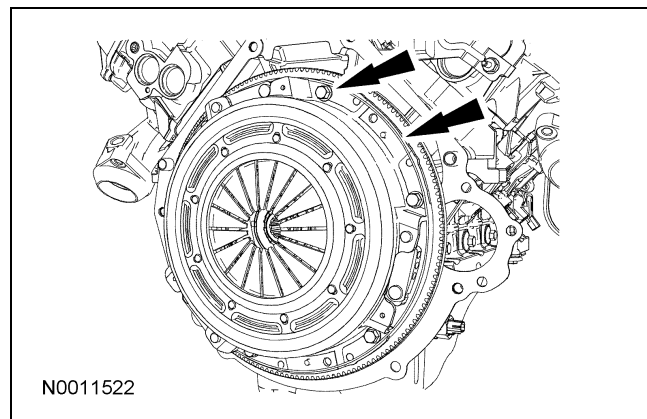

Removal

1. Remove the transmission. For additional information, refer to Section 308-03B.
2.  **CAUTION: Loosen the bolts evenly to prevent damage to the pressure plate.**
NOTE: If the pressure plate is to be reused, index-mark the pressure plate to the flywheel.
 Remove the 6 pressure plate bolts, the pressure plate and the clutch disc. Discard the pressure plate bolts.

REMOVAL AND INSTALLATION (Continued)

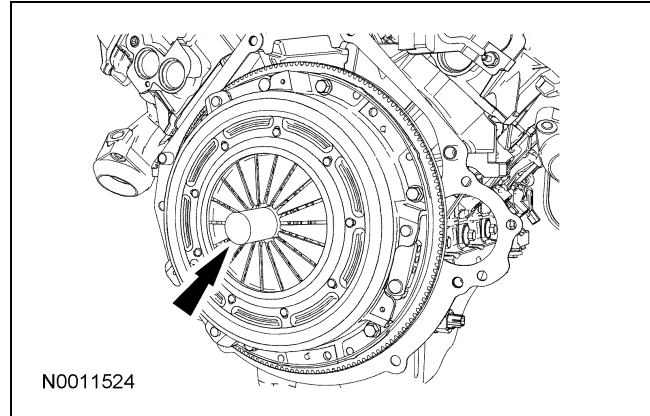
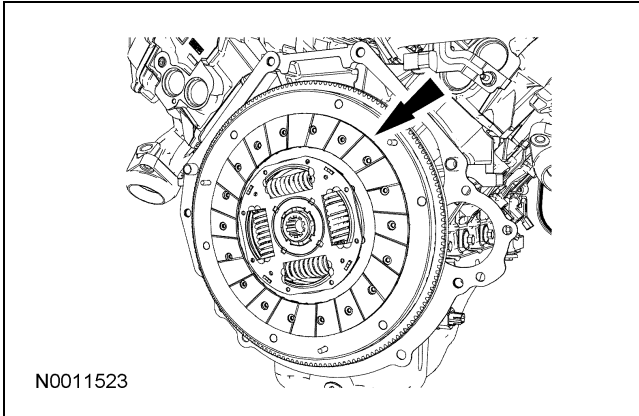

Installation

- NOTE:** Clean the clutch pressure plate and flywheel with a commercial alcohol-based solvent so surfaces are free from oil film. Do not use cleaners with a petroleum base.

NOTE: If installing the original pressure plate, align it using the index marks made during removal.

NOTE: Always install new pressure plate bolts.

Using a suitable clutch aligner, position the clutch disc on the flywheel, then install the pressure plate and new pressure plate bolts.

- Tighten the pressure plate bolts in 2 stages in a star pattern.
 - Stage 1: Tighten to 45 Nm (33 lb-ft).
 - Stage 2: Tighten an additional 60 degrees.
- Remove the clutch aligner.

- NOTE:** Before securing the transmission to the engine, connect the clutch hydraulic line to the slave cylinder.

Install the transmission. For additional information, refer to Section 308-03B.

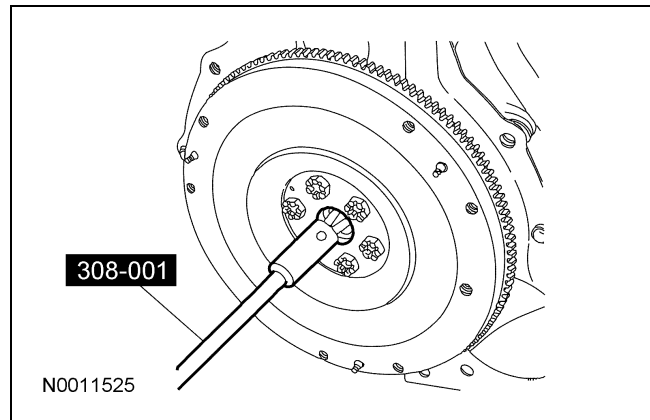

- Bleed the clutch hydraulic system. For additional information, refer to Section 308-00.