

GENERAL PROCEDURES

Transmission Draining and Filling

Material

Item	Specification
Threadlock and Sealer TA-25	WSK-M2G351-A5

1. With the vehicle in NEUTRAL, position it on a hoist. For additional information, refer to Section 100-02.
2. **NOTE:** Drain the transmission while the transmission fluid is warm.
Remove the drain plug.
 - Position a drain pan under the transmission.

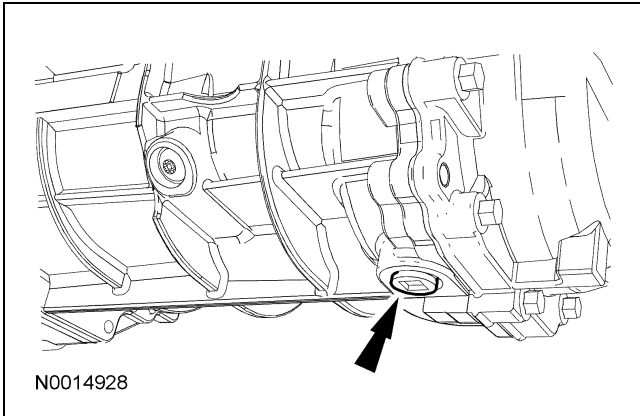

3. Apply threadlock and sealer and install the drain plug.
 - Tighten to 27 Nm (20 lb-ft).

4. **NOTE:** Prior to removal, clean the area around the fill plug.
Remove the fill plug.

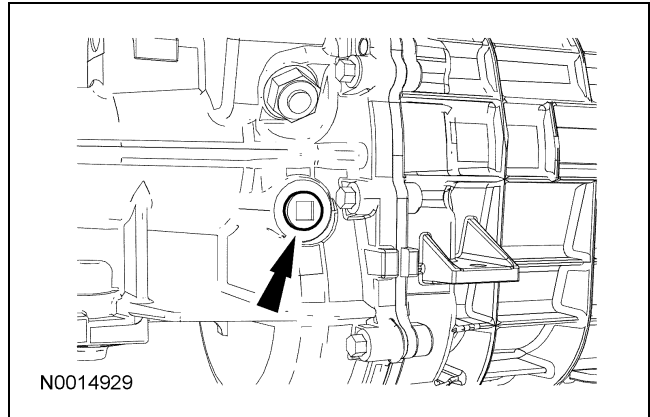

5. **NOTE:** Do not overfill the transmission. This will cause transmission fluid to be forced out of the case.

Fill the transmission with the recommended fluid.

- Make sure the fluid is 12.7 mm (0.5 in) below the filler opening for the correct fluid level. Using a tie strap, measure an inch from the end and bend it at a 90-degree angle, place it in the filler opening and check the fluid. Adjust the fluid level as necessary.

6. Apply threadlock and sealer and install the fill plug.
 - Tighten to 25 Nm (18 lb-ft).