

## REMOVAL AND INSTALLATION

### Driveshaft — 4.6L

#### Material

Item	Specification
Threadlock and Sealer TA-25	WSK-M2G351-A5

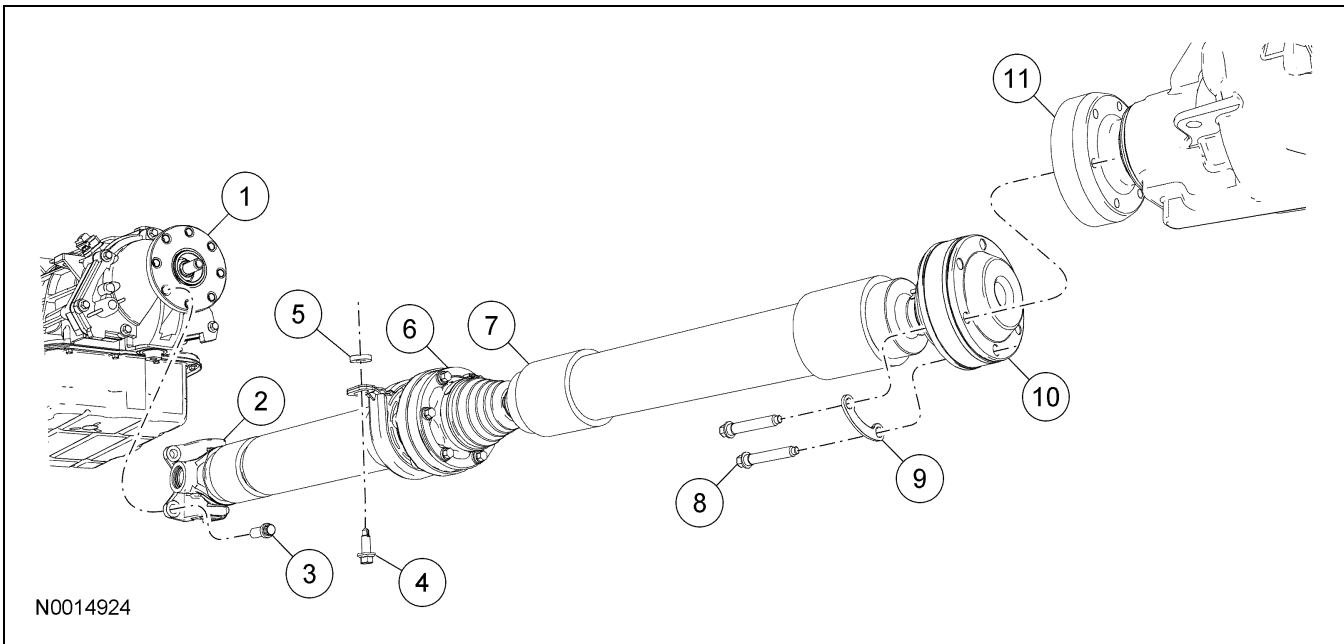

Item	Part Number	Description
1	4K177	Transmission output flange
2	—	Driveshaft flange (part of 4K145)
3	N800594-S100	Driveshaft flange bolt
4	N506434-S439	Center bearing bolt
5	W710432-S300	Spacer
6	—	Center bearing (part of 4K145)
7	4K145	Driveshaft assembly
8	W708259	Constant velocity (CV) joint bolt (6 required)
9	4682	CV joint washer (3 required)
10	—	CV joint (part of 4K145)
11	4851	Pinion flange

- Index-mark the driveshaft to maintain alignment during installation.

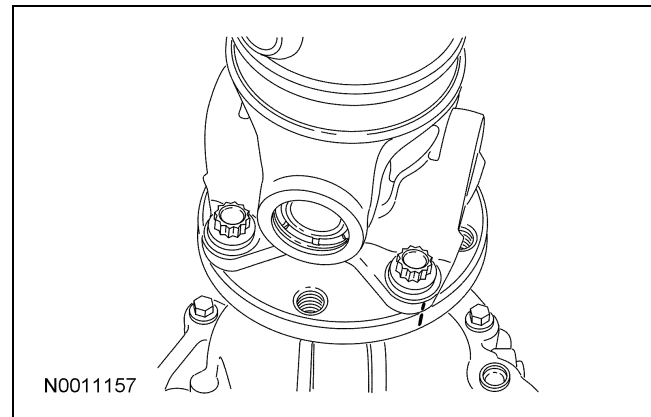

#### Removal and Installation

- With the vehicle in NEUTRAL, position it on a hoist. For additional information, refer to Section 100-02.

## REMOVAL AND INSTALLATION (Continued)

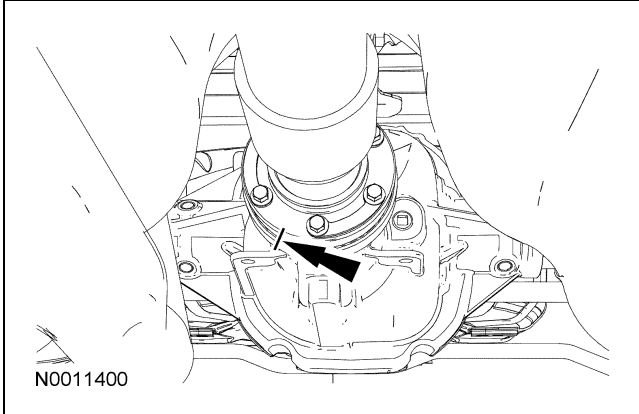

3. Remove the 6 constant velocity (CV) joint bolts and CV joint washers, then disconnect the CV joint from the pinion flange.

- Discard the CV joint bolts.
- To install, tighten to 55 Nm (41 lb-ft).

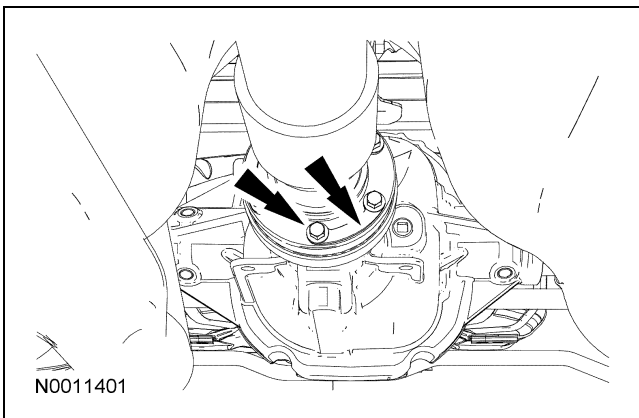

4. Remove and discard the 4 driveshaft flange bolts.

- To install, tighten to 103 Nm (76 lb-ft).

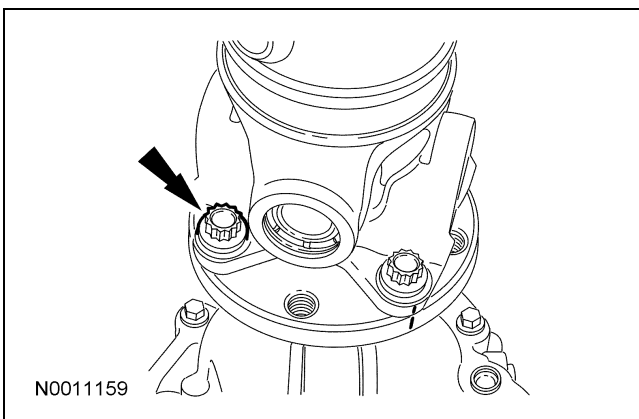

5. **⚠ CAUTION:** The driveshaft flanges fit tightly on the transmission flange pilot. Never hammer on the driveshaft or any of its components to disconnect the driveshaft flange from the transmission flange pilot. Pry only in the area shown, with a suitable tool, to disconnect the driveshaft flange from the transmission flange pilot.

Using a suitable tool as shown, disconnect the driveshaft flange from the transmission flange pilot.

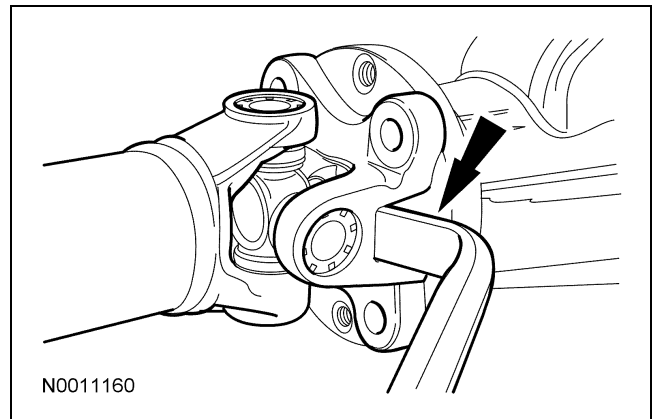

6. Remove the 2 center bearing bolts and spacers, then remove the driveshaft.

- Discard the center bearing bolts.
- To install, tighten to 48 Nm (35 lb-ft).
  - Install the center bearing bolts finger tight until after the front and rear flanges are tightened to specifications.

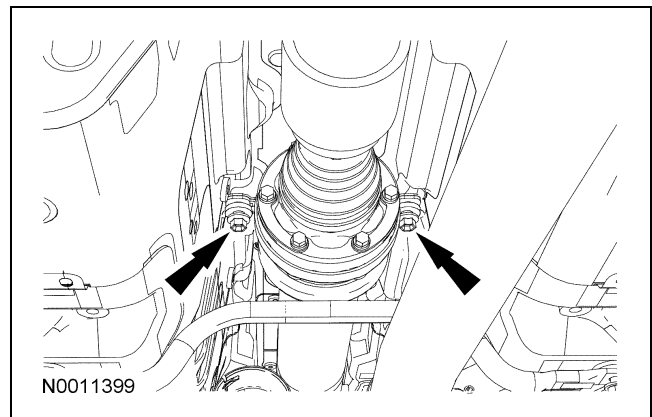

---

**REMOVAL AND INSTALLATION (Continued)**

7.  **CAUTION:** The driveshaft flanges fit tightly on the transmission output flange pilot. To make sure that the driveshaft flange seat squarely on the transmission output flange, tighten the driveshaft flange bolts evenly in a cross pattern.

 **CAUTION:** If new driveshaft flange bolts are not available, coat the threads of the original driveshaft flange bolts with threadlock and sealer.

**NOTE:** Tighten the CV joint bolts evenly in a star pattern.

To install, reverse the removal procedure.

- Install new fasteners.
-