

REMOVAL AND INSTALLATION

Brake Pads

Special Tool(s)

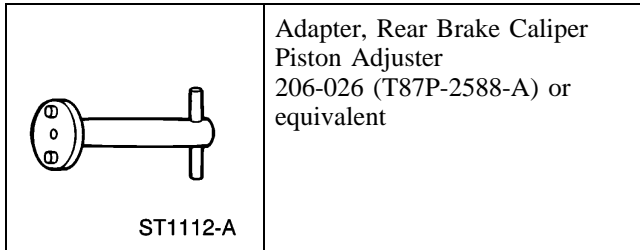

Material

Item	Specification
Silicone Brake Caliper Grease and Dielectric Compound XG-3-A	ESE-M1C171-A

Removal

⚠ WARNING: Use of any other than approved DOT 3 motor vehicle brake fluid will cause permanent damage to brake components and will render the brakes inoperative. Failure to follow these instructions may result in personal injury.

⚠ WARNING: Brake fluid contains polyglycol ethers and polyglycols. Avoid contact with eyes. Wash hands thoroughly after handling. If brake fluid contacts eyes, flush eyes with running water for 15 minutes. Get medical attention if irritation persists. If taken internally, drink water and induce vomiting. Get medical attention immediately. Failure to follow these instructions may result in personal injury.

⚠ CAUTION: Brake fluid is harmful to painted and plastic surfaces. If brake fluid is spilled onto a painted or plastic surface, immediately wash it with water.

1. With the vehicle in NEUTRAL, position it on a hoist. For additional information, refer to Section 100-02.

2. **⚠ CAUTION:** Do not use caliper sight hole to retract pistons as this can damage the pistons and boots.

⚠ CAUTION: When removing the brake caliper, never allow it to hang from the brake hose. Provide a suitable support.

Remove and discard the 2 brake caliper bolts and position the brake caliper aside.

3. **⚠ CAUTION:** Install new pads if worn to or past the specified thickness above the metal backing plate or rivets. Install pads in complete axle sets.

Remove the brake pads and discard the spring clips.

4. Measure the brake disc thickness.
 - Install a new brake disc if not within specification. For additional information, refer to Brake Disc in this section.
5. Inspect the brake caliper.
 - If leaks or damaged boots are found, install a new brake caliper. For additional information, refer to Brake Caliper in this section.
6. Inspect the brake caliper anchor plate assembly.
 - Check the guide pins and boots for binding and damage.
 - Replace worn or damaged pins. Lubricate the pins with the specified grease.
 - Install a new brake caliper anchor plate if it is worn or damaged.

Installation

1. **⚠ CAUTION:** Do not allow grease, oil, brake fluid or other contaminants to contact the pad lining material. Do not install contaminated pads.

NOTE: Install all hardware supplied with the pad kit.

Install the 2 new spring clips and the brake pads.

REMOVAL AND INSTALLATION (Continued)

- Using the special tool, compress the brake caliper piston into the brake caliper bore.

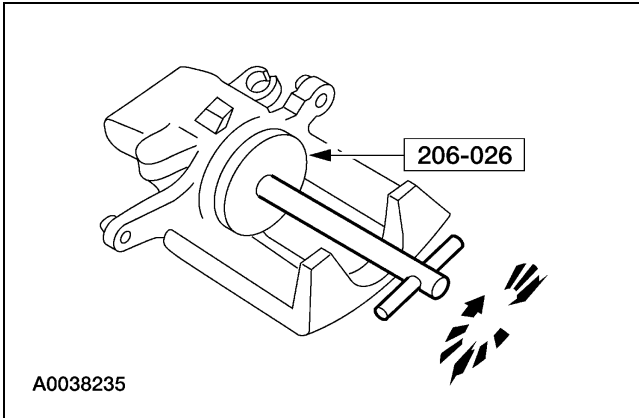

- Position the notch in the caliper piston up and down to align with the alignment pin on the brake pad.
- Position the brake caliper on the anchor plate and install the 2 bolts.
 - Tighten to 33 Nm (24 lb-ft).
- Test the brakes for normal operation.