

REMOVAL AND INSTALLATION

Brake Disc

Material

Item	Specification
High Temperature Nickel Anti-Seize Lubricant XL-2	ESE-M12A4-A
Metal Brake Parts Cleaner PM-4 (Canada CPM-4)	—

Removal

1. **⚠ CAUTION: Do not allow the brake caliper, brake pads and anchor plate assembly to hang from the brake hose or damage to the hose can occur.**

Remove the 2 brake caliper anchor plate bolts and position the brake caliper, brake pads and anchor plate aside as an assembly.

- Support the brake caliper, brake pads and anchor plate assembly using mechanic's wire.

2. If equipped, remove and discard the retainer nuts.

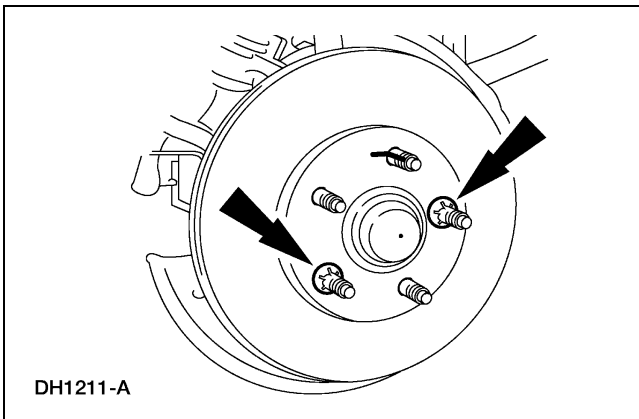

3. Remove the brake disc.

Installation

1. **⚠ CAUTION: Do not use an abrasive sanding disc since it will remove paint or other protective finishes from the wheel or metal from the mounting surfaces, adversely affecting corrosion protection and brake disc lateral runout.**

Remove corrosion from the wheel mounting surfaces, both disc mounting surfaces and hub mounting surfaces.

- Use brake parts cleaner to clean the brake disc and hub surfaces.
- Apply anti-seize lubricant to the hub mounting surfaces to prevent future corrosion.

2. Install the brake disc.
3. Position the brake caliper, brake pads and anchor plate assembly.
 - Install the 2 bolts and tighten to 115 Nm (85 lb-ft).