

REMOVAL AND INSTALLATION

Brake Pads — 4.6L (3V)

Material

Item	Specification
High Performance DOT 3 Motor Vehicle Brake Fluid PM-1 (Canada CPM-1)	ESA-M6C25-A or WSS-M6C62-A
Metal Brake Parts Cleaner PM-4 (Canada CPM-4)	—

Removal

⚠ WARNING: Use of any other than approved DOT 3 motor vehicle brake fluid will cause permanent damage to brake components and will render the brakes inoperative. Failure to follow these instructions may result in personal injury.

⚠ WARNING: Brake fluid contains polyglycol ethers and polyglycols. Avoid contact with eyes. Wash hands thoroughly after handling. If brake fluid contacts eyes, flush eyes with running water for 15 minutes. Get medical attention if irritation persists. If taken internally, drink water and induce vomiting. Get medical attention immediately. Failure to follow these instructions may result in personal injury.

⚠ CAUTION: Brake fluid is harmful to painted and plastic surfaces. If brake fluid is spilled onto a painted or plastic surface, immediately wash it with water.

⚠ CAUTION: Do not allow the brake fluid to come in contact with the adhesive backing on the brake pads. If brake fluid is spilled onto the brake pads new pads must be installed.

⚠ CAUTION: Use only specified brake parts cleaner. Use of other cleaners may leave a residue on the brake caliper preventing the brake pads adhesive surface from bonding with the brake caliper.

1. Check the brake fluid level in the brake fluid reservoir.
 - If required, remove fluid until the brake master cylinder reservoir is half full.

2. With the vehicle in NEUTRAL, position it on a hoist. For additional information, refer to Section 100-02.

3. **NOTE:** Loosen but do not remove the brake caliper bolts.
Loosen the 2 brake caliper bolts.

4. **⚠ CAUTION:** Do not use the brake caliper sight hole to retract the pistons as this can damage the pistons and boots.

⚠ CAUTION: When removing the brake caliper, never allow it to hang from the brake flexible hose. Provide a suitable support.

Remove the 2 brake caliper anchor plate bolts and position the brake caliper anchor plate, brake caliper and brake pads aside.

5. **⚠ CAUTION:** When the brake pads are separated from the brake caliper, new brake pads must be installed. The brake pads are one-time use only.

NOTE: The brake pads must be separated from the brake caliper before the brake caliper can be removed from the anchor plate.

Using a suitable tool, separate the brake pads from the caliper.

6. Remove and discard the 2 brake caliper bolts.
7. Remove and discard the brake pads and the 4 spring clips from the brake caliper anchor plate.
8. Inspect the brake caliper for leaks or damaged boots.
 - Install a new brake caliper if required. For additional information, refer to Brake Caliper — 4.6L (3V) in this section.

REMOVAL AND INSTALLATION (Continued)

9. Inspect the brake caliper anchor plate assembly.
 - Check the guide pins and boots for binding or damage.
 - Lubricate the guide pins with the specified grease as necessary.
 - Install a new brake caliper anchor plate if it is worn or damaged. For additional information, refer to Brake Caliper Anchor Plate — 4.6L (3V) in this section.
2. Clean the old adhesive from the brake caliper piston and fingers using the specified brake parts cleaner.
3. Position the brake caliper anchor plate on the wheel knuckle and install the 2 bolts.
 - Tighten to 115 Nm (85 lb-ft).
4.  **CAUTION: Do not allow grease, oil, brake fluid or other contaminants to contact the brake pad or caliper mating surface. Do not install contaminated pads.**

Installation

1. **NOTE:** Protect the pistons and the boots when compressing the brake caliper piston into the caliper bore.

Compress the caliper pistons into the brake caliper.

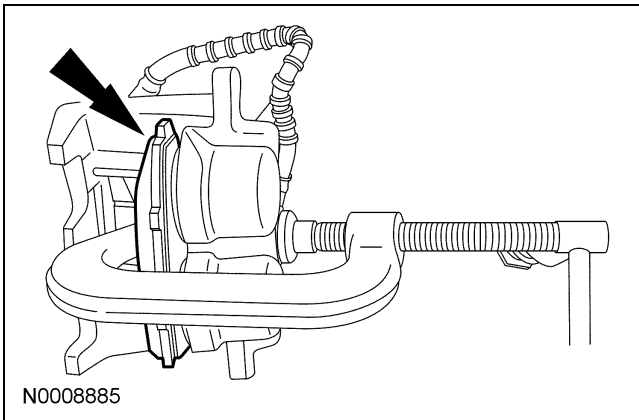

- NOTE:** Install all the new hardware supplied with the brake pad kit.
Install the 4 new spring clips and brake pads.
5. Position the brake caliper on the anchor plate and install the 2 new bolts.
 - Tighten to 34 Nm (25 lb-ft).
 6. With the vehicle engine running, apply 89-133 N (20-30 lb) of pressure to the brakes for approximately 1 minute, to make sure the brake pads adhere to the caliper before any contamination can be introduced.
 7. Test the brakes for normal operation.