

GENERAL PROCEDURES

Camber Adjustment — Front

1. **NOTE:** If camber adjustment is necessary to resolve a vehicle alignment issue, then slotting the strut at the lower mounting plate and installing a cam bolt is an acceptable method. This procedure should not be routinely performed with all alignments and only after all other possible sources have been inspected and corrected as necessary.

With the vehicle in NEUTRAL, position it on a hoist. For additional information, refer to Section 100-02.

2. Remove the wheel speed sensor bolt and position the sensor aside.

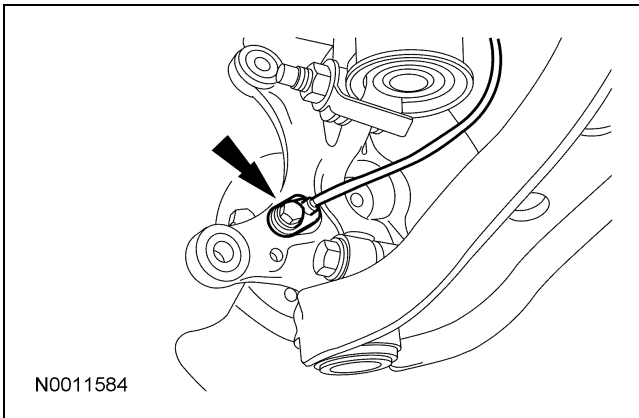

3. Remove the brake line bracket bolt and disconnect the wheel speed sensor wire from the bracket.

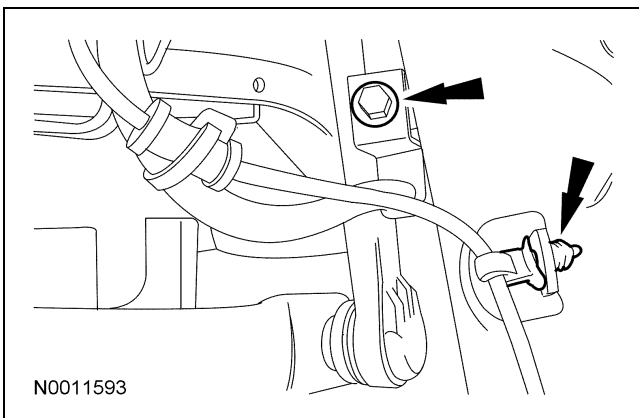

4. **CAUTION:** Support the wheel spindle using mechanic's wire.

Note the orientation of the strut-to-spindle bolts and flag nuts, then remove and discard the bolts and flag nuts.

5. **CAUTION:** Do not enlarge the holes any more than indicated by the etchings on the strut mount.

Using a suitable grinding tool, enlarge the strut-to-wheel spindle lower mounting holes as indicated by the etchings in the strut lower mount.

- Remove any burrs.
- Clean and paint any exposed metal.

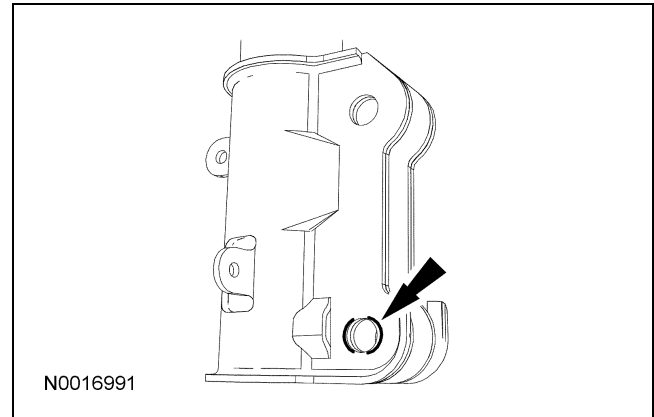

6. **NOTE:** Do not fully tighten the cam bolts until the alignment has been corrected.

Position the wheel spindle and install a cam adjusting nut and bolt in the bottom location, using the opposite orientation noted in Step 4. Then install a new bolt and flag nut in the top location.

- Tighten the upper bolt and cam nut until snug.
7. Position the brake line bracket and install the bolt, connect the wheel speed sensor wire to the bracket.
 - Tighten to 20 Nm (15 lb-ft).
 8. Position the wheel speed sensor and install the bolt.
 - Tighten to 15 Nm (11 lb-ft).

GENERAL PROCEDURES (Continued)

9. Using alignment equipment and the manufacturer's instructions, measure the front camber.
 10. Using the cam bolt, adjust the front camber until it is within specifications.
 - Tighten the upper bolt and the cam nut to 200 Nm (148 lb-ft).
 11. Recheck the front camber settings, adjust as necessary.
-