

Mustang Times

THE OFFICIAL PUBLICATION OF
The Mustang Club of America



VOL. 2 NO. 12

DECEMBER 1978

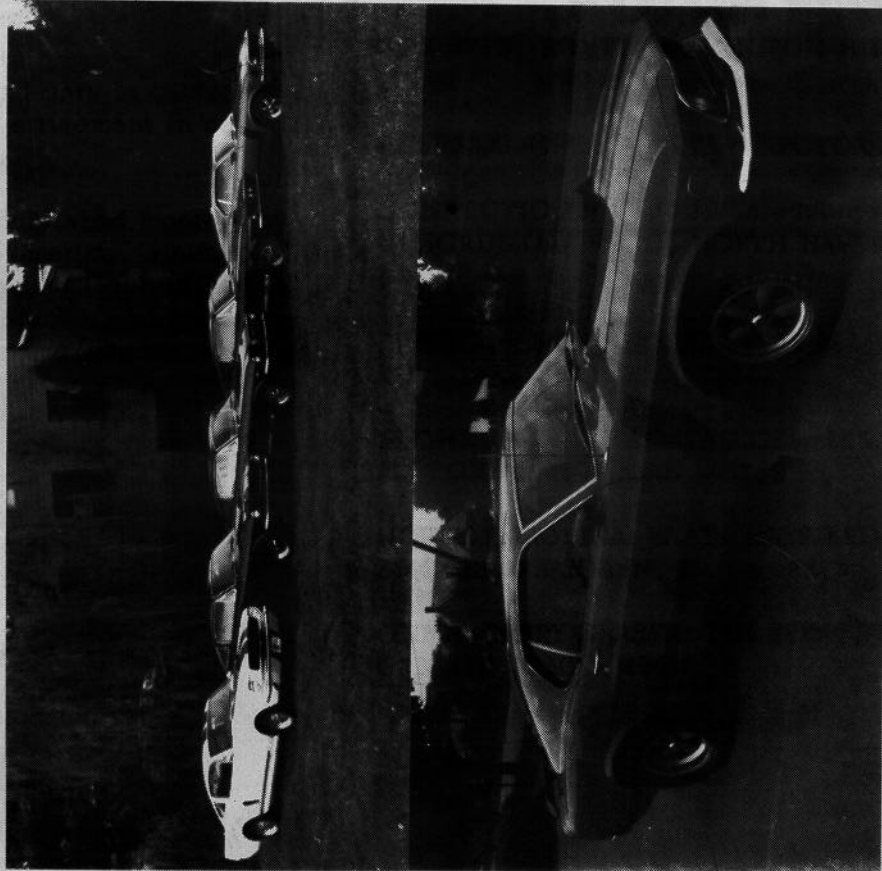

CARS OF THE MONTH:
JUDY & TONY BRANDA
ALTOONA, PENNA.



ST. ASOINOS GRANT HING

SPECIAL INTEREST CARS
P. O. Box 2088
Westminster, California 92683



65-73 MUSTANG 69-70 "BOSS"

PARTS

Phone (714) 897-3335

ARNOLD MARKS

Mustangs, etc.

sales • parts • repairs

14843 BESSEMER ST. VAN NUYS, CA 91411 • (213) 787-7634



**ATLANTA AUTO
Classics**

APPRECIATING AUTOS

2881 BUFORD HWY
ATLANTA, GA 30329
PH. 404-325-2333

GREG MILLS

NOS MUSTANG PARTS

Specializing in new-obsolete parts
"Fair prices--Good Service"

JIM BRIDGES
321 MELROSE CIR.
LENOIR, N. C. 28645
704-728-6021

JACK R. SHOOK
OWNER

9 A.M.-6 P.M.
TUES.-SAT.

SHOOK AUTO SUPPLY

3807 HARWIN #R
HOUSTON, TEXAS 77036
(713) 782-6630

PARTS AND ACCESSORIES
INSTALLATION AVAILABLE

■ GT 350 ■ MUSTANG ■ GT 500 ■



TONY D. BRANDA

MUSTANG AND SHELBY PARTS
703 GRANT AVENUE

ALTOONA, PA. 16602—Phone (814) 942-1069

We Specialize in the Detailing and the Finishing Touch

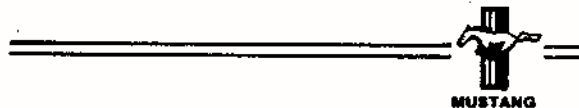

GLAZIER'S MUSTANG BARN

R. D. No. 1
Souderton, Pennsylvania 18964
215-723-9674

RESTORATIONS
Specializing in 65-66
Convertibles and Parts
We Buy - Sell - Trade



**ATLANTA AUTO
Classics**
APPRECIATING AUTOS

2881 BUFORD HWY
ATLANTA GA 30329

PH 404 325 2333

J HENLY MAGEE, VICE PRES

404-241-5158

Specializing in Mustang & Thunderbird

National Parts Depot
2908 SW 4th Court
Gainesville, Florida 32601



Toll Free Order Number: 1-800/874-7595
In Florida: 904/378-2473

1965-68 Mustang Catalogs — \$1.00



JIM OSBORN
AUTOMOBILE LITERATURE

3228 PHEASANT DR
DECATUR, GEORGIA 30034



PHONE 275-7439



MR. MUSTANG

Mustang Parts & Restoration

CARL PENDLEY

5088 WOLF CREEK PIKE
DAYTON OHIO 45426

GARY GODDARD'S

MUSTANG PARTS
NOS AND USED
BOX 5 BOX 550
COVINGTON, GA. 30209
404-787-3793

SEND LARGE S.A.S.E. FOR FREE
SIX PAGE PARTS LIST..

AUTOMOTIVE



MARINE

Specializing in Parts For All Ford Products

Total Performance

J & E
RACING

SALES

ENGINES

SERVICE

Call (313) 468-FORD

40631 Irwin Mt. Clemens, Mich. 48045

JOHN VERMEERSCH



CLASSIC INSURANCE
AGENCY

Hoke S. Rawlins
Residence 485-3588

639 Lindbergh Way, N.E.
Atlanta, Georgia 30324
404-263-2264



BRENT DANNEMAN
EARLY MUSTANG CARS & PARTS

85 DALRYMPLE RD.
ATLANTA, GA. 30328

(404) 393-3040
(404) 688-9520



Valley Ford Parts Company

11604 VANOWEN STREET
NORTH HOLLYWOOD, CALIF. 91605

NEW AND USED
1964-67 Mustang
and Shelby Parts

(213) 785-9266

County
AUTO PARTS, INC.
FOREIGN PARTS DIVISION

Contact "BUZZ"
Area Code 803
Phone: 359-5163

Location
Hwy. 6 & Flat Springs Rd.
Route 8, Box 436-A
Lexington, S. C. 29072



Early 1966-66
Mustang Parts

California Auto Sales

MUSTANGS Only

SEDANS - CONVERTIBLES

5863 Washington Boulevard
Culver City, California 90230

938-0191



P. O. Box 5917 — Lakeland, Florida 33803
Phone 813 - 644-2300

NEW and USED PARTS and ACCESSORIES
We specialize in 65-67 new and used parts
Both Buy and Sell

MUSTANG "PONY" RINGS

As Seen At
Grand National Meet

Sterling - \$35 pp.
Write for gold prices



Sizes 6-12

REM-TEK
222 Howard St.
Clinton, TN 37716

Richard A. Buckner
#1719

THE ORIGINAL
OBSOLETE FORD PARTS CO.
NEW, GENUINE FORD-MUSTANG PARTS
NASHVILLE, GA. 31639
(912)-686-2470
Ford Parts Specialists
since 1950

TRIANGLE AUTO
SALES & SERVICE

302 W.
Chatham
Street



NEW

USED

MUSTANG PARTS

RAY WHITLEY
OWNER

919-467-7882

Cary,
N.C.
27511

THE FORD PARTS WAREHOUSE

Courthouse Square
Liberty, Kentucky 42539

606-787-6216



MUSTANG TIE TACK OR LAPEL PIN

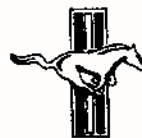

\$7.00 + 50¢ Handling

Actual Size

Leonard Wolfe
2321 May Drive
Burlington, N.C. 27215

The Mustang Club of America

NATIONAL HEADQUARTERS

P. O. BOX 447

LITHONIA, GEORGIA 30058

MEMBERSHIP * The membership fee is \$15.00 annually and will be due upon the expiration date of your membership.

PAYMENT OF DUES * The Mustang Club of America cannot be responsible for cash sent through the mail. We request any transaction be made by check or money order and made payable to The Mustang Club of America.

CHANGE OF ADDRESS * Please notify the Club immediately of any change in your address.

OPERATING BUDGET * The Mustang Club of America does not pay its officers salaries or hourly wage earnings. All money received goes directly into operating the Club.

MUSTANG TIMES does not accept responsibility for accuracy of advertisements and/or advertisers. Any advertisers who have proven unreliable or cause complaints from our members will be refused advertising space.

Liability for legitimate clerical and typographical errors extend only to correcting and re-running of advertisement in our next available issue.

MUSTANG TIMES is published monthly by The Mustang Club of America, a non-profit corporation in the State of Georgia and is dedicated to the restoration and preservation of Mustangs/Shelbys/Bosses vehicles from 1965 through 1973.

CLASSIFIED ADS: Free to members. Non-members 10¢ per word. Members are limited to 3 free ads per month with a combined total not to exceed 150 words or 50 per each ad. Free ads are limited to 3 consecutive months.

1978 OFFICERS

NATIONAL PRESIDENT-TREASURER
JIM OSBORN, Stone Mountain, Georgia

NATIONAL VICE-PRESIDENT
GEORGE WHITE, SMYRNA, GEORGIA

NATIONAL SECRETARY
WALLY GREENFIELD, GRAYSON, GEORGIA

NATIONAL BOARD OF DIRECTORS:

LEE GREENFIELD, GRAYSON, GA. (10-1-78)

GEORGE WHITE, SMYRNA, GA. (10-1-78)

JACK HUFF, LAWRENCEVILLE, GA. (10-1-79)

BILL HATFIELD, FRANKLIN, N.C. (10-1-79)

DENNY ARRINGTON, LAWRENCEVILLE, GA.
(10-1-79)

JACK YEAGER, DECATUR, GA. (10-1-79)

MAX EPPS, CHURCH HILL, TN. (10-1-79)

DICKY DILLS, LILBURN, GA. (10-1-79)

LARRY DOBBS, LAKELAND, FL. (10-1-79)

CHARLIE JONES, JR., NASHVILLE, GA. (10-1-79)

NATIONAL REGIONAL GROUP DIRECTOR:

MAX EPPS, ROUTE #6, CHURCH HILL, TN.
37642

REGIONAL GROUP STATE DIRECTORS:

CONNECTICUT: Alec J. Karacsonyi
44 SCRUB OAK ROAD, NORTH HAVEN, CT.
06473

FLORIDA: LARRY DOBBS, 4532 REMINGTON
RD., LAKELAND, FL. 33803

MICHIGAN: JERRY OSTALECKI, 9951 RIVERDALE
REDFORD, MICHIGAN 48239

NORTH CAROLINA: W. T. HATFIELD, RT. 2,
BOX 638, FRANKLIN, N. C. 28734

OHIO: LARRY GRASER, 1418 FORRESTER DR.,
OREGON, OHIO 43616

**MUSTANG TIMES ADVERTISING RATES
ONE ISSUE**

1/4 PAGE.....\$20.00
 1/2 PAGE..... 30.00
 3/4 PAGE..... 40.00
 FULL PAGE..... 50.00

FULL YEAR

1/4 PAGE..... 150.00
 1/2 PAGE.....200.00
 3/4 PAGE..... 250.00
 FULL PAGE..... 300.00

PLEASE SEND ALL MUSTANG TIMES CORRESPONDENCE TO: JIM OSBORN, 3229 PHEASANT DRIVE, DECATUR, GEORGIA 30034 404-241-5158

NOTICE: We are presently in an in-stock situation on the 8" cloth jacket emblems. If you had a patch on back-order, you should be receiving it shortly.

MUSTANG TIMES BACK ISSUES:

August, 1977.....\$1.00
 October, 1977.....\$1.00
 December, 1977.....\$1.00
 January, 1978.....\$1.00
 March, 1978.....\$1.00
 April, 1978.....\$1.00
 May, 1978.....\$1.00
 June, 1978.....\$1.00
 July, 1978.....\$1.00
 August, 1978.....\$1.00
 September, 1978.....\$1.00
 October, 1978.....\$1.00
 November, 1978.....\$1.00

NOTE: The following decals are available to Club Members from The Mustang Club of America at discount prices: 289-2V, 289-4V, 289 Hi-Po., 65-66 Innerfender & Glove Box, and 65-66 Jacking Instructions. Your choice \$1.50 each.

CHILTON'S 1965-73 MUSTANG TUNE-UP & REPAIR MANUAL 270 PAGES., REGULAR PRICE \$6.95, MEMBER COST \$ 5.50.

THE MUSTANG CLUB OF AMERICA OFFICIAL ACCESSORIES:

Cloth Jacket Emblems 3"	\$ 2.00
Cloth Jacket Emblems 8"	5.00
T-Shirts (Adults) S-M-L-XL	4.00
T-Shirts (Children) S-M-L	3.50
Unlined Jackets (Adults)	
S-M-L-XL (Includes emblems)	15.00
Unlined Jackets (Children)	
S-M-L (Includes emblems)	14.00
Lined Winter Jackets (Adults)	
S-M-L-XL (Includes emblems)	22.00
Lined Winter Jackets (Children)	
S-M-L (Includes emblems)	18.50
Windshield Decal	1.00
1978 Eastern National Dash Plaque	2.00
1978 Grand National Dash Plaque	2.00
Mustang Club of America Front License Plate	3.00

 ***** EASTERN NATIONAL MEET *****

Rooms at the Quality Inn, South in Chattanooga, Tennessee for our Eastern National Meet May 25-27, 1979, are limited. NOW is the time to make sure you have a room.



MEMBERSHIP APPLICATION

YES!!! I want to join the most responsive and fastest growing organization in the world dedicated to the preservation, care, history and enjoyment of the 1965-73 Mustangs 1965-69 Shelby. Enclosed is \$15.00 U. S. & Canada, \$20.00 foreign.

Please send my new member's packet immediately and the next 12 issues of *The Mustang Times*.

NATIONAL HEADQUARTERS • P. O. BOX 447 • LITHONIA, GEORGIA 30058

Name _____ Spouse _____

Address _____

Type of car currently owned _____ Regional Group Info _____

OWNERSHIP NOT ESSENTIAL ENTHUSIASM IS

QUESTION of the MONTH

WHAT WAS THE FIRST YEAR SHOULDER HARNESSES WERE STANDARD ON A MUSTANG?

The first two members who correctly answer our question of the month will receive a Mustang Club of America T-Shirt. These answers are to be submitted on a postcard (Noting on this card also your shirt size) and mailed to the National Headquarters, P.O. Box 447, Lithonia, Georgia 30058

NOVEMBER QUESTION OF THE MONTH:

What was the first year AM/FM stereo radio was available in the Mustang?

Correct Answer: 1968

Winners: Tom Cushing
Shelbyville, Tn.

G. Sheridan
Nunica, Mi.

OCTOBER QUESTION OF THE MONTH:

What was the first year that a rear window defogger was available as an option on a Mustang?

Correct Answer: 1968

Winners: Patricia Dersey
Pinckney, Mi.

Arthur Dice, III
Rock Glen, Pa.

FROM OUR PRESIDENT

I'd like to start off this month by wishing a speedy recovery to Ellen Sprayberry, our newly hired secretary. We hope our "mess" didn't get the best of her.

As you will see on Pages 16 and 17, we have started publishing the 1979 Mustang Club of America Judging Rules. These will be continued in the January issue. We also intend to publish

them in a Rules Book that will be available to members at a small charge. We hope to have these printed and ready for distribution by the end of January. Please read them carefully as they will be used at ALL meets during 1979.

Regional Groups: We must receive your notification, no later than January 5, 1979, as to whom your national board of director member is. Also, and very important, we need the mailing address for 1979 from each regional group, immediately. We are planning on listing all regional groups with a mailing address in all advertisements during the year 1979.

I am very sorry to hear that AMT Corporation (maker of model car kits) has gone out of business. We do understand that Matchbox has acquired them. We also understand that Mustang models are extremely hard-to-find in most parts of the country. At the Eastern National Meet, we will accept metal and plastic Mustang/Shelby cars that have been re-worked by the children. They will be judged according to the age of the child and the work that has been performed to them. We want this to be a contest for our children; not the dads.

A hearty welcome is made to our latest regional group, Treasure State Mustang Club, 3630-5th Avenue, South, Great Falls, Montana 59405. A special thank you to all your members for their hard work in forming this club.

The December issue of Hot Rod Magazine has a special 12-page Mustang section and even though they did not mention The Mustang Club of America, it is certainly worth reading.

The Osborn Family have moved into a temporary location until their new house is finished. Their temporary address is: 1334A Stone Race Drive, Stone Mountain, Ga. 30083. Phone number is (404) 498-0644.

The Officers and Board of Directors of The Mustang Club of America would like to wish you a Very Merry Christmas and a Prosperous Mustang New Year!

REGIONAL GROUP NEWS



The following are the minutes of our Membership Meeting of November 21, 1978.

Ernie McFall and his brother were visiting with us from Norton, Virginia.

Name tags were discussed and decision was made to order from Doc Taylor. The Club will buy the tags and members ordering name tags will repay the Club. Ernie Stout is handling this transaction with Doc Taylor.

Club officers have received no word on National's work on judging guidelines.

Don Wolfe still has Mustang caps for sale, originally purchased by Club for sale to members.

Christmas Banquet details are being finalized for December 22nd, the Friday before Christmas at Ramada Inn in Kingsport. Ernie Stout is lining up a band for this function; hopefully, Tommy Dickens. Our club will bear all expenses for the banquet. Charles Carey and Alvie Bright will purchase gifts to be given away. Limitations on gift expenditure will be \$250.00. These gifts will be given away during the entire program, including the dance. Tickets will be used with one per adult family and each child receiving a separate ticket.

New officials for the club were nominated by the membership to fill the vacancies of 5 officers and 3 new board of directors. Don Wolfe and Max Epps by virtue of their having been president, will automatically remain on the Board of Directors.

The membership nominated Charles Carey, Freddie Jones, Don Cox, Ernie Stout, Jack Ladd, Sid Miller, Hunter Perkins, Wayne Bryant, Bill Henderson and Alvie Bright.

A Board of Directors meeting was held immediately afterwards with the following slate of officials elected:

President	Charles Carey
Vice President	Don Cox
Secretary	Ernie Stout
Treasurer	Jack Ladd
Parliamentarian	Alvie Bright

The following were elected to the Board of Directors:

Freddie Jones
Bill Henderson
Wayne Bryant

Our club membership certainly wants to go on record of expressing our appreciation for the guidance and leadership of Don Wolfe during 1978. Don's enthusiasm and craftsmanship have been an inspiration to all.

Don Cox, Secretary

VOLUNTEER REGIONAL GROUP

At the last meeting of the Volunteer Regional Group, November 16, 1978, the Officer's reports were given and old business was taken care of.

Harold Shipley's resignation was announced and he was then replaced by Doug Gass, and we would like to welcome Doug to the Board.

All members were urged to send in their vote for National Board Members. Bob Murphy was chosen to represent our club in Georgia and we're sure he'll do a great job.

Since our club is still rather new, all members agreed that our present officers should stay in office for the following year until the next election.

Please remember, all volunteers to help with the February show are welcome and we appreciate those who have already volunteered.

Carol Pearson, Secretary

REGIONAL GROUP NEWS

NORTHWEST OHIO REGIONAL GROUP

The fall meeting of the Northwest Ohio Regional Group was held at the Holiday Inn, Ferrysburg, on October 29, 1978. There were 12 members and 5 Mustangs in attendance.

It was reported that the membership stood at 30 and that an all-out membership drive should be made during the winter. There was a discussion concerning the Chattanooga Meet and it was suggested that we travel to the Meet in a caravan. Also discussed was the possibility of a rally race.

The next meeting will be March 24, 1979, at Hugh Black's in Bucyrus, Ohio. Election of officers, a dinner at Woods Steer Barn in Upper Sandusky, Ohio, lodging at the Holiday Inn and movies of the past meets will be the main agenda.

The meeting ended with inspection of members' cars which included two coupes and three convertibles.

Larry J. Graser, Ohio Group
Director

If you are interested in joining the Northwest Ohio Regional Group, please contact Larry J. Graser, 1418 Forester Drive, Oregon, Ohio 43616.

"INDY. MUSTANGS" REGIONAL GROUP

We were very pleased with our first meeting. 18 joined our regional club and 5 joined the National Club.

The following members were chosen for the following positions:

President	Garvin G. Sexton, II
Vice President	Steve Zenobia
Sec./Treasurer	Ann Zenobia
Historian	Judy Sexton
Parliamentarian	Wilbur Roy

It was agreed that our meetings would be held on the first Wednesday of each month in the Conference Room at Foxworthy Ford Dealer.

Our door prize was won by Linda Pager. Our prize was a Mustang Club of America license plate which was donated by the National Headquarters. The "Indy Mustangs" thank you.

Our club wishes to thank Foxworthy Ford Dealership for backing our club. We were informed by Parts Manager, John Blocher that he would double his Mustang parts' inventory. Most of the club members discovered that a lot of parts they have combed the junk yards for are still available through your Ford dealer and at a much lower price.

At the end of our meeting, a few members did a little parts' swapping and then went outside to look over each others Mustangs.



The October meeting was brought to order by Pat Makowski, President. The trip to Frankenmuth was discussed, all the plans are still on and everyone expects to have a good time.

Pat introduced our new editors, Manual and Lois Bagnaschi to everyone.

The Mustang Club of America, 1979 Eastern National Mustang Show fliers were passed out. The show will be next May 25-27, 1979 in Chattanooga, Tennessee hosted by the Scenic City Regional Group.

Greg Smith introduced by John Hasikin, is a Master Mechanic, Technician & certified in eight different areas. Mr. Smith will be on hand at our meetings to answer any questions you might have about your Mustangs or any problems you may be having with them.

This meeting was our election night. It has been a pleasure serving you for the past year. Everyone seems to be participating more. Once you fill an

cont'd on Pg. 14

TECHNICAL ADVISORS

1965-68 MUSTANG RESTORATION ADVISOR Fred R. Glazier, Jr. R. D. #1 Souderton, Pa. 18964 (215) 723-9674	MUSTANG MECHANICAL ADVISOR John Vermeersch Total Performance 40631 Irvin Mt. Clemens, Mich. 48045 (313) 468-FORD	MUSTANG FEATURES & ACCESSORY ADVISOR Alec J. Karacsonyi 44 Scrub Oak Road North Haven, Ct. (203) 239-4382 06473	1969-73 MUSTANG RESTORATION ADVISOR Bill Dillard 108 Jones Avenue Calhoun, Ga. 30701
---	---	--	--

TYING THINGS TOGETHER

At several auto shows, non-Mustang and Mustang related, I have seen a few very original belt buckles. So a short time ago, I decided to make an original "Mustang" belt buckle. The ideal logo to start from is the glove box emblem from the 1966 model. Another logo is one from the door panels of the deluxe interior of a 1969 Mustang. So I ran to my local Ford dealer only to find both were no longer available...

But, upon leaving, I saw a Mustant II and there on the inside door panel was the logo I needed. The part number is as follows:
D4ZZ-6920802-A

After getting the part, I went to a local leather shop where i purchased a blank belt buckle. The owner assured me that these blank buckles can be had readily all over the country so no one should have any problem.

Affixing the horse was no problem. Two holes were drilled in the buckle and the horse inserted. The extra length of the pins was cut off and the rest was peened over forming a rivet head.

That is it, simple, inexpensive and original.

Alec Karacsonyi, Tech Advisor

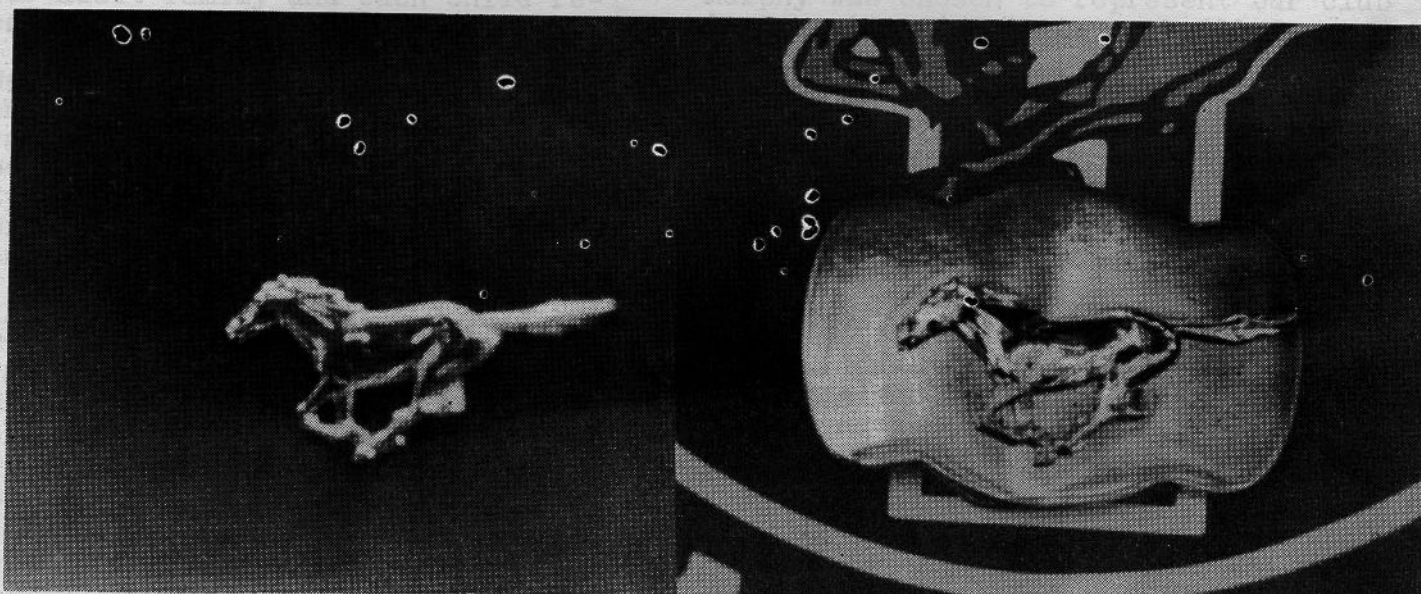

CAR OF THE MONTH

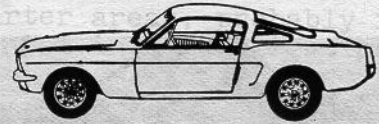

TONY D. BRANDA

MUSTANG AND SHELBY PARTS

703 Grant Avenue, Altoona, Pa. 16602

Phone (814) 942-1869

We Specialize in the Parts and Decals for
Detailing and the Finishing Touch

This month's car of the month is unusual due to the fact that we are featuring not one but a collection of Mustangs and Shelbys.

The December Cars of the Month belong to Judy and Tony Branda of Altoona, Pennsylvania. Being a dealer of Mustang and Shelby parts, you would expect them to have a nice car or two...but pictured on this page are five outstanding Shelbys and Mustangs from their collection. They have owned 35 Shelbys and 25 Mustangs since 1974. These are the ones they kept for themselves.

Car #1: 1966 Shelby (white with blue stripes) which was purchased by them in 1977 and is the 197th Shelby built. The car has many 1965 items on it--so as in Tony's words, "This car enjoys the best of both years." The car is totally restored and has 53,000 actual miles.

Car #2: 1966 Shelby Hertz (black with gold stripes) is automatic, is totally restored and has 61,000 miles and was purchased in 1976.

Car #3: 1966 Mustang GT 2+2 fast-back. This is a genuine K-car and was purchased new in 1966 by a priest who was over 50 years old. This car is dark blue, 4-speed, Rally-Pac, AM/tape player, Rally wheels, totally original with 71,000 actual miles. Tony purchased the car from the priest who told him he knew Ford had a better idea.

Car #4: 1967 Shelby GT 350 (black) totally restored and was purchased in 1978 in Texas. There is a total of 39,000 miles on the car.

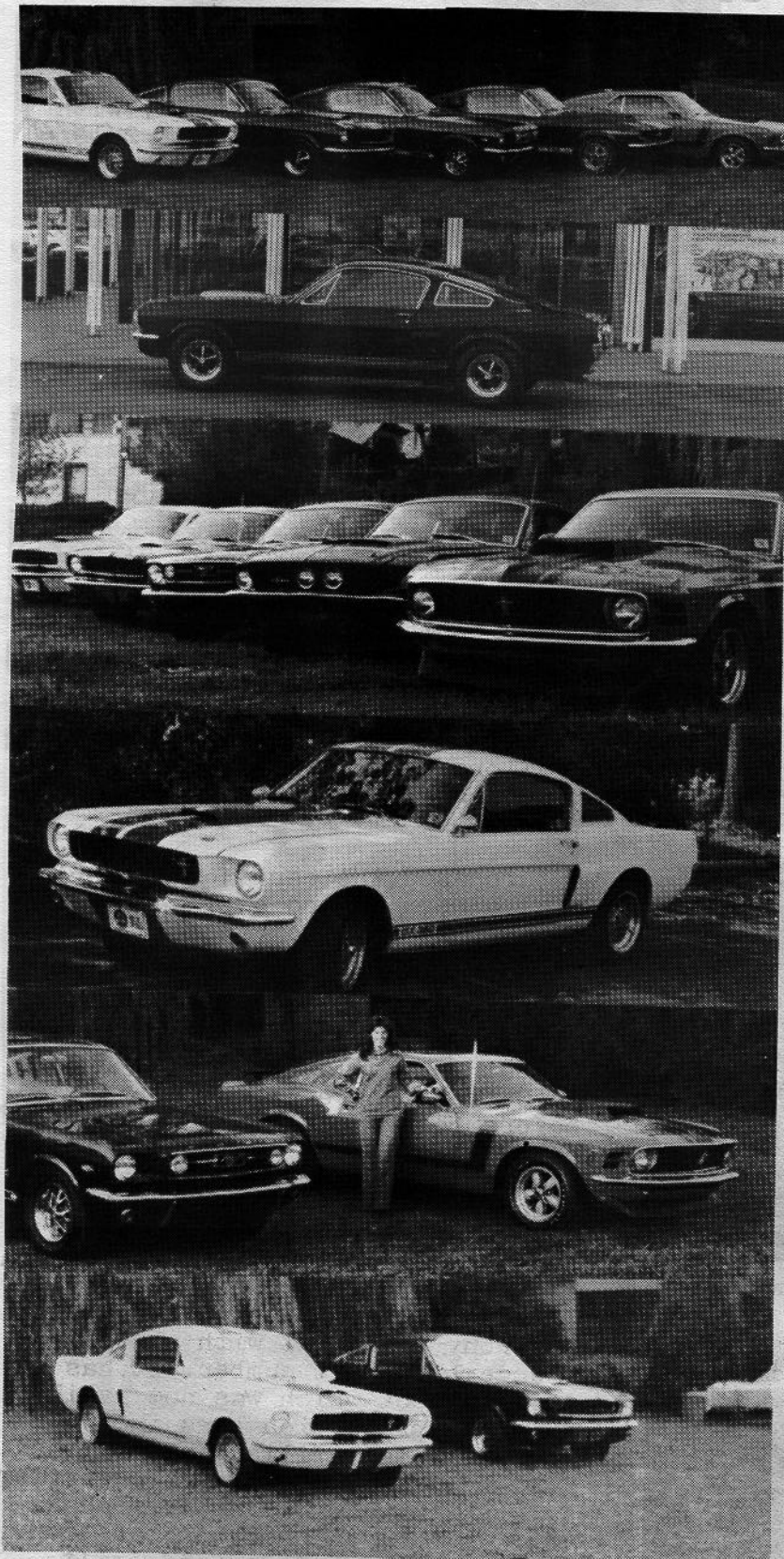

cont'd on Pg. 14

A RARE FIND

Regarding the search for the oldest Mustang; in my last letter I wrote that we had just purchased an early 1964½ convertible, with an indicated build date of 2/15/64 (15B) three weeks before the official start of production on March 9th. I have since checked with the Ford Archives and the Ford production statistics department in Dearborn, both of which had no information which would contradict that this car was one of a group of special order cars built specifically for the Mustang introduction at the New York World's Fair in 1964. The region designation (DSO) on the door identification tag is 842011 indicating a Ford reserve special order.

I have enclosed several photographs one of which shows a steel plate, welded to the underside of the front frame cross-member, which was used to attach the car to a moving conveyor which took Fair visitors through the Ford exhibit. (See page 163 of "The Ford Road" book).

I purchased the car from the original owner, a Ford employee, who bought the car from the Ford Company car resale lot in Dearborn in December of 1965. He explained that after the car was used at the Fair, it, along with the rest of the other display cars was returned to Detroit where it was re-trimmed before being sold.

The car has other unique features which can be attributed to its unusual early life at the Fair. It has standard type trim with a bench seat. It also has door courtesy lights similar to those used with the Pony trim, but with a 1961 Thunderbird part number. It has an AM tape deck which was not available for production cars in 1965 and completely filled and finished metal joints where the rear quarter fits to the door "B" post, indicative of show car body preparation. It was also scheduled and built with a 200 CID engine which was not available until later, although it was available in other Fords in

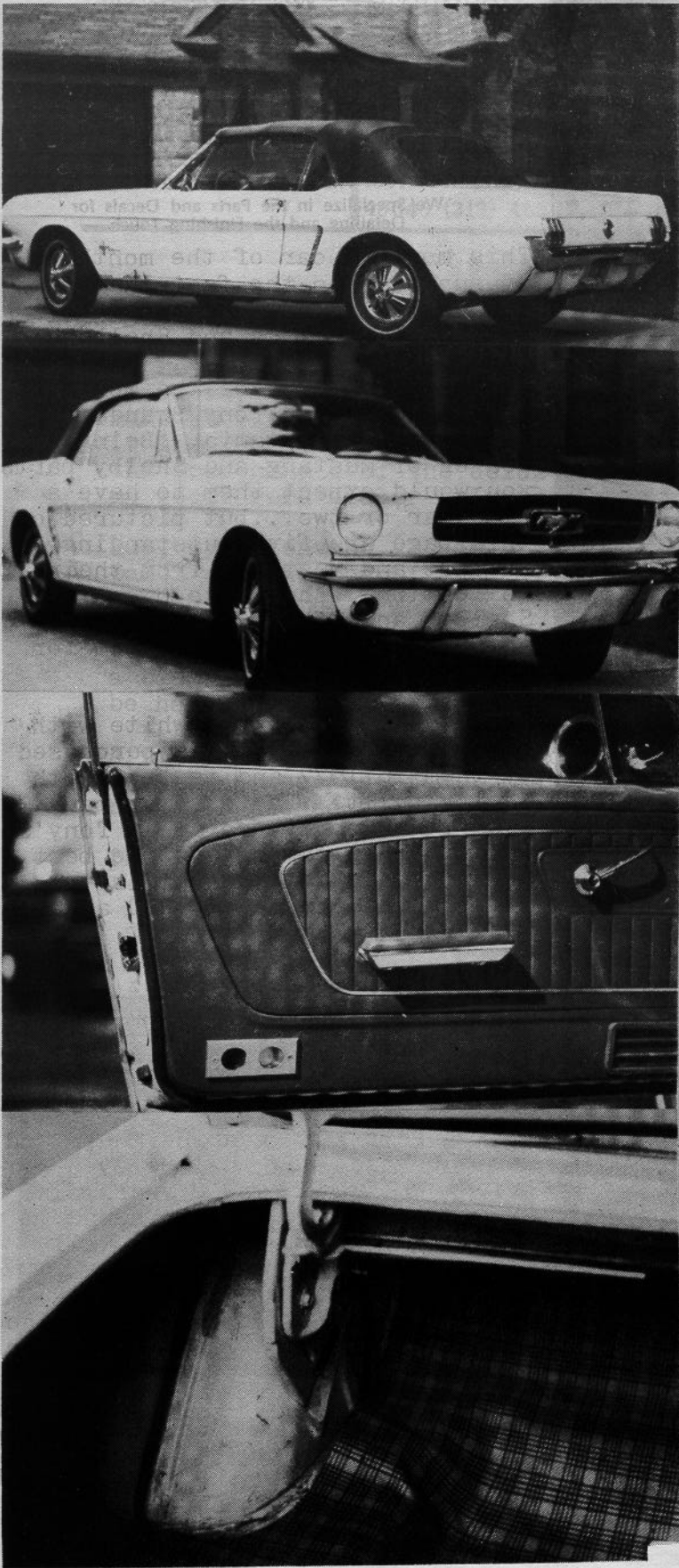

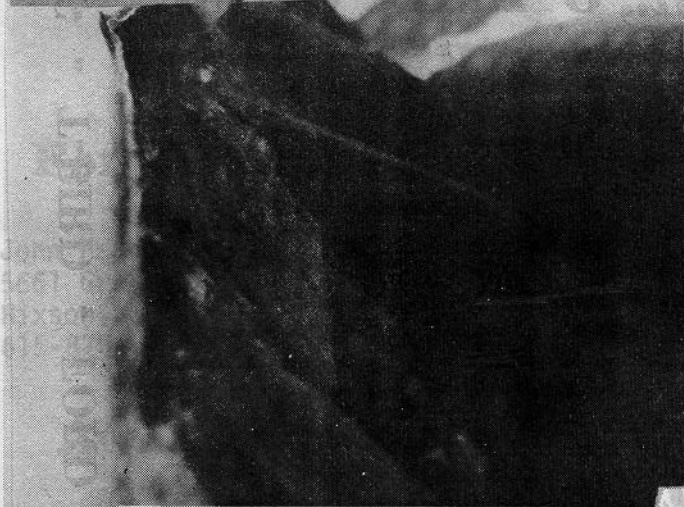

1964. A special wiring harness was run to the trunk and interior rear quarter areas, probably for supplemental interior lighting required for display purposes. The V.I.N. is handwritten in "magic marker" on top of the gasoline tank, suggesting all the major parts were collected and assigned to a certain car prior to assembly, definitely not a production procedure. The interior handles and heater controls are of the early 1965-type.

The car has 35,000 miles, and generally is in very good condition, with the original tires, and the spare still in the trunk. There were no alterations or modifications ever made to the car except replacement of the water pump. There is some evidence of rust but only very minor in the typical Mustang locations. The underside is perfect and structurally like new.

It is our intention to completely restore the car, leaving all of the features exactly as when the car was built. We would like to have it ready for Chattanooga next spring, if at all possible. I am sure if we enter it in the judging, there is bound to be some question as to originality and authenticity. However, this is a very unique car and it will be shown exactly as it was sold by Ford.

We intend to continue our research, working with the Ford Archives to find photographs taken at the Fair, or any other information which would apply to these very early Mustangs. If any other members can help in this research project, we would appreciate hearing from them.

Gary Schweitzer
Grosse Pointe Woods, Michigan

EDITOR'S NOTE:

The Mustang Club of America and "The Mustang Times" would like to thank you, Gary, for allowing us to share this unique and interesting history of one of the first Mustangs ever built.

NOTE TO CLUB MEMBERS: If any of you have and information concerning this research project, please send to National Headquarters and we will forward it to Gary.

FORD - MERCURY - LINCOLN - EDSEL - MUSTANG - T-BIRD - FORD TRUCK

FORD - MERCURY - LINCOLN - EDSEL - MUSTANG - T-BIRD - FORD

THIRD ANNUAL *All Ford Swap Meet*

INDOOR FLEA MARKET

RESTRICTED TO PARTS & CARS MADE BY FORD

January 19 and 20, 1979

Nashville, Georgia

80,000 SQUARE FOOT BUILDING

10'x10' Inside Space - \$15.00

10'x20' Inside Space - \$30.00

For Information And Reservation Forms Write:

Ford, Inc. Box 787, Nashville, Ga. 31639

Or Call: 912-686-5101

- ● ● 24 Hour Security Personnel
- ● ● Drive-In To Unload Or Load
- ● ● Adjacent Free Parking
- ● ● Non-Ford Parts Not Allowed
- ● ● Any Year Ford Parts Welcome
- ● ● Food Available On Premises
- ● ● No Car Auction
- ● ● No Car Show
- ● ● 60 Motels In 25 Mile Radius
- ● ● 600 Spaces Available

Friday, January 19th., 8 A.M. - 6 P.M.

Saturday, January 20th., 8 A.M. - 6 P.M.

VENDORS WILL BE ALLOWED TO SET UP

NOON THURSDAY, 18th.

Sponsored By Ford, Inc. Nashville, Georgia 31639

ENDORSED BY NASHVILLE CHAMBER OF COMMERCE

Come To Nashville, Ga. 1979

MUSTANG CLUB OF AMERICA

1979

EASTERN NATIONAL

MUSTANG SHOW

MAY 25, 26, 27

HOSTED BY:

**Scenic City Regional
Chattanooga, Tennessee**

SHOW SITE:

Eastgate Center

HEADQUARTERS:

Quality Inn South

For more information contact:

John Henderson
5661 Grayshore Lane
Hixson, TN 37343
615-875-6991

Larry McCloud
6402 Ridgelake Road
Hixson, TN 37343
615-842-4560

Doug Sult
P. O. Box 63
LaFayette, GA 30728
404-741-1512

Award For Regional Club With Most Participants

"No Car Displays Permitted"

cont'd from Pg. 7

office and it's time to leave, you often wish you did a little more. I'd like to thank everyone who co-operated with me during this year.

The following is a listing of our 1979 officers:

President	John Haskin
Vice President	Vacant
Secretary	Sharon Stephenson
Treasurer	Gini Scherer
Reg. Group Representative	Gary Schweitzer

New Board members will take office in January.

Lois Bagnaschi, Editor

'60s Mustang Owners Are Riding High

Chicago Tribune

LOS ANGELES — Within the costlier precincts of southern California, where a Mercedes or even a Rolls-Royce is as commonplace as a Gucci shoe, the true connoisseur drives a '65 Ford.

Not just any '65 Ford, of course, but a sleek and now classic Mustang convertible, the car that is beginning to rival the regal Thunderbird itself as America's contemporary automotive masterpiece.

Mustang clubs are dotted about the country. Some dealerships sell nothing but restored Mustangs, and other firms specialize in renovating them. There is even a monthly magazine called "Mustang News."

The intense interest in the Mustang, particularly the 1965 and 1966 models, has driven up the cost until many now sell for more than twice their original price. One collector in Georgia recently turned down \$12,000 for a mint-condition '66 convertible.

That proposed price was considered grossly excessive by most Mustang experts (and there are thousands of knowledgeable aficionados who deserve that title). But prices of \$6,000 are not unusual — still remarkable for a car that sold new for only about \$2,800.

cont'd from Pg. 9

Car #5: 1970 Mustang Boss 302 (grabber orange with black stripes) Tony purchased this car new in 1970 and it is totally original with only 17,000 miles. Has four-speed, slats, spoilers and is loaded. Tony has had a number of people try to buy this car. Tony states it would be necessary that he sell his wife first.

Judy and Tony Branda
Altoona, Pennsylvania

EDITOR'S NOTE: We would like to thank Judy and Tony Branda for allowing us to feature their fine collection of Mustangs and Shelys as December's Cars of the Month.

Sorry, fellas, eat your heart out! This is Judy and Tony's personal collection and they aren't for sale.

Common Car

The early-Mustang phenomenon is all the more amazing because it is a common car; millions have been manufactured and are still on the road. Ford built 417,000 Mustangs in 1965 alone, setting an industry record for first-year production.

There are all sorts of Mustang freaks. Some collect only '65 or '66 convertibles (the body changed in '67). Others are interested solely in the Shelby Mustang, a modified fastback with high-performance options.

Specialties are taken so seriously that mixing models is often avoided at runs and rallies sponsored by Mustang organizations.

The proud owner of a tropical turquoise '65 topless with all the original trim would naturally tend to regard himself as superior to the driver of the '68 coupe that lacked its original upholstery.

And the owner of a '66 Shelby GT350 equipped with the optional whinny horn and the "glowing horsey," a translucent plastic piece that highlights the grill ornaments ... well, like the Cabots and the Lodges, he would confer mostly with God.

It's Serious

"They tend to take this stuff very seriously," said Bob Page, editor of Mustang News. "Every collector wants his car to be absolutely authentic, and most have their specialties."

Page knows of collectors who have six or more Mustangs. One Californian has an inventory of 15, including four prize convertibles that he has put aside for his grandchildren, the oldest of whom is 14.

"For one thing, the styling is still very up-to-date," said E. K. Beaumont, operator of a California dealership that sells only reconditioned Mustangs. "The Mustang was the first of its type; it started a brand-new trend in automotive design. A whole generation of cars has copied it, from the Camaro to the Celica."

Another apparent explanation is price. Even though immaculate, early-model convertibles bring top dollar, it is still possible to latch on to one needing a little work for around \$3,000. Prices for a coupe are even less.

"Most people who are into Mustangs never have been car collectors before," Page said. "A lot of women are doing it. They like the fact that they can get mechanical work and even body work done at almost any Ford dealership. Nearly all of the parts are still available."

This contrasts with the hapless Thunderbird owner who, after shelling out as much as \$20,000 for one of those '55 two-seaters that were the gnawing envy of his youth, must then be prepared to go through endless torture and expense to find replacement parts and capable mechanics.



LOOK FORWARD TO MORE NEXT MONTH!

1979 MUSTANG CLUB OF AMERICA SHOW RULES & JUDGING GUIDELINES

1. A contestant must decide at the time of entry which class he wants to enter his car. Once the car has been entered, its class cannot be changed without the concurrence of MCA for that particular meet. MCA will not be responsible for deciding if a car is modified or not. The class, however, may be changed at the next meet.
2. Before a car (stock or modified) receives its official entry number, it must pass through the technical inspection. The car owner will be required to be with the car at this time.
3. Any car that does not have a Ford drive train will not be allowed to compete.
4. To provide for consistency in judging, a judge will judge the same phase on all cars they judge.
5. A team of judges will complete their phase of judging on a car before starting another car.
6. Modified cars will not be judged for authenticity points. They will be awarded modified points only for areas that are modified. No points will be given for stock. They will be judged for Quality of Workmanship, Condition and Cleanliness.
7. Best of Show will be the car that receives the highest composite score. Modified cars will not be eligible for Best of Show unless there is specifically a Best of Show Modified.

MECHANICAL CHECK LIST

<u>1. Operational:</u>	<u>POINTS</u>
Headlights (high and low beam)	1
Parking lights	1
Turn signals	1
Tail lights	1
Running lights (if applicable)	1
License plate light	1
All dashboard lights for instruments and controls (including high beams and turn light indicators)	1
Courtest lights including console light (if applicable), activated by both doors and manual switch	1
Windshield wipers	1
Rally-pac (if applicable)	1
Clock (if applicable)	1
Radio (if applicable)	1
Window and vent window operation	1
Seat motion	1
Parking brake	1
Air vents	1
Air conditioning (if applicable)	1

LOOK FORWARD TO MORE NEXT MONTH!

POINTS

Remote control mirror (if applicable)	1
Door opening and closing	1
Door locks (both key and button locking)	1
Hook and trunk lid opening and closing	1
Convertible top (if applicable)	1

DEDUCT ONE POINT FOR EACH OPERATIONAL FAILURE

MAXIMUM DEDUCTION IS 15 POINTS

2. Running:

Engine start	3
Engine noise	2
Engine idle	1
Leaks (oil, water, transmission fluid)	1
Exhaust noise and smoke	1
Operation of transmission, clutch and brakes	2

QUALITY OF WORKMANSHIP, CONDITION AND CLEANLINESS

ENGINE COMPARTMENT:

POINTS

1. Engine block with attached Cast Iron Parts (including all all motor mounts and attaching parts) Paint, condition and cleanliness.	10
2. Engine Electrical System (including distributor, coil, spark plug wire loom assembly, generator/alternator, starter and attaching parts): Paint, condition and cleanliness	6
3. Fuel System (including fuel pump, carburator, all fuel lines accelerator linkage): Condition and cleanliness	6
4. Other items attached to engine (includes air cleaner, valve covers, oil breather cap, including hoses, etc.). Dress-up kits must be complete.	5
5. Engine Compartment Walls (including underside of hood, hood hinges and latch dowels): runs on walls-no points deducted, perfect wall can have points deducted: Paint, finish and cleanliness.	10
6. All non-electrical parts attached to engine compartment walls (including hood latch assembly, brake master cylinder, battery carrier, steering column and steering gear housing and wind-shield washer assembly): Finish, condition and cleanliness	6
7. Electrical wiring (including starter solenoid, voltage regulator, battery and starter cables, wiring looms and junction blocks): Condition and cleanliness	6
8. Cooling system (includes radiator and cap, fan and belts, radiator and heater hoses and clamps): Paint finish and cleanliness	8
9. Stock points	14

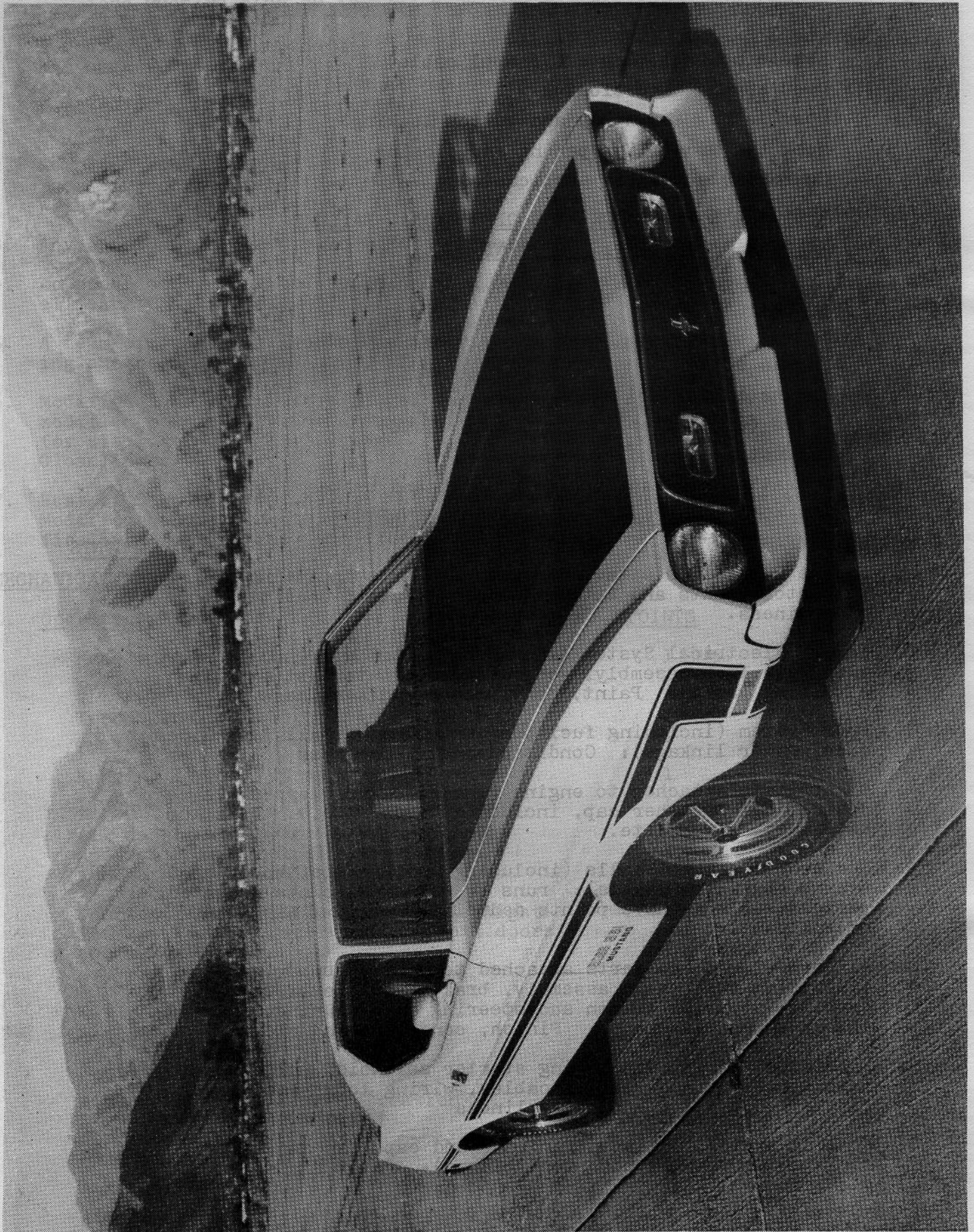

LOOK FORWARD TO MORE NEXT MONTH!

NOS MUSTANG PARTS
CHRISTMAS/NEW YEARS SPECIAL

65 Inst housing B/C \$14.50; 65/66 Inst housing woodgrain \$14.75; 66 Inst housing B/C \$14.50; 67 Inst housing B/C \$12.35; 67 Inst housing brushed alum. \$21.50; 68 Inst housing B/C \$22.00; 65/66 Temp. gauge \$6.45; 67/68 Temp. gauge \$7.50; 65/66 Ign switch bezel \$1.75; 67/68 Ign switch bezel \$2.50; 67 Parking lamp assy \$10.55; 65/66 Parking lamp assy L or R \$9.50; 65/66 Parking lamp lens \$1.65; 67/68 Parking lamp lens \$2.40; 65/68 Turn signal lever \$2.00; 65/66 Horn ring std. \$22.00; 65/67 Horn ring woodgrain \$12.25; 67 Horn ring std \$12.25; 68/69 Horn ring std \$13.25; 65/66 Back-up lamp assy L or R \$9.15; 67/68 Back-up lamp assy L or R \$9.15; 65/68 Back up lamp lens \$1.30; 65/66 Apron-fender (battery panel) \$14.90; 65 "Mustang" script 4 1/2" \$2.90; 65/66 "Mustang" script 4 7/8" \$4.00; 65/66 "Mustang 2+2" script \$5.85; Decals: Air Cleaner, 200 CID, 260, 289, 289 4V, 302, 302 4V, 351, 351 4V, 390, 390 4V, 65/66 Jacking Instructions, 65/66 Service specs, 65/66 Tire pressure specs, \$1.50 Please add 10% UPS shipping and postage. Prices good until January 30, 1979

CIRCLE CITY MUSTANG- MC

3309 Candlewood Drive Dothan, AL. 36301

MUSTANG NEWS

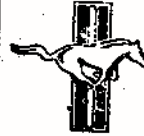

The Monthly Magazine Devoted Exclusively to MUSTANGS

Each issue packed full of:

- * Articles
- * Technical Data
- * Readers Section
- * Ads for Cars & Parts
- * Coming Events
- * Plus many valuable tips

SUBSCRIBE TODAY!!!!

SUBSCRIPTION - 1 Year - 12 Issues, \$ 10.00

Sent to MUSTANG NEWS

1141 Cameron Way
Stockton Calif. 95207
(209) 478-6142

64-66 Mustang steel patch panels

exact reproduction of original

COMING SOON!
Superior Floor Pans!
4 overlapping Sections
Fronts \$35
Rears \$42

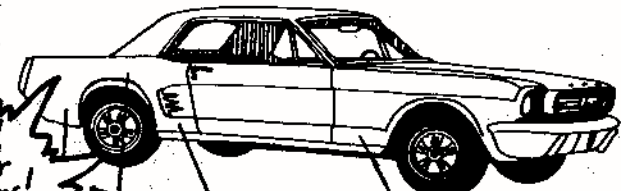

These panels have been developed from years of experience in restoring sports and special interest autos in our own shop.

We specialize in the re-creation of special sheet metal parts for special applications. We're developing a complete selection of underbody parts for early Mustang as well as other cars such as BMW 2002, Porsche, and others. We will be introducing many new Mustang body parts in the near future.

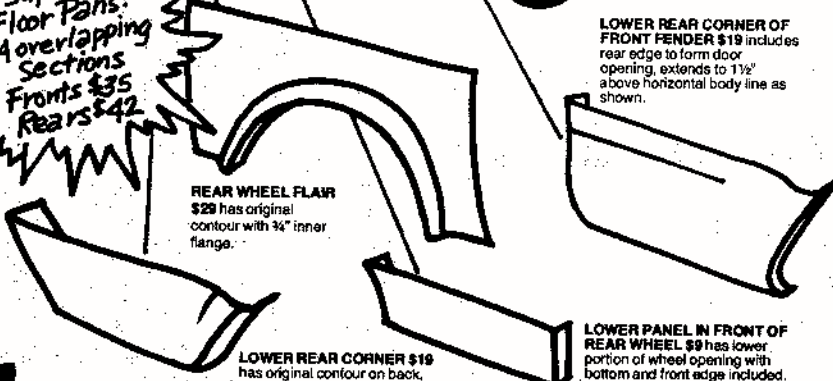

LOWER REAR CORNER OF FRONT FENDER \$19 includes rear edge to form door opening, extends to 1 1/2" above horizontal body line as shown.

REAR WHEEL FLAIR \$29 has original contour with 3/4" inner flange.

LOWER REAR CORNER \$19 has original contour on back, bottom and wheel opening.

LOWER PANEL IN FRONT OF REAR WHEEL \$9 has lower portion of wheel opening with bottom and front edge included.

Parts are "deep draw" die stamped in our own shops (no middle man) of American steel, the same thickness or greater than original.



We will ship U.P.S., COD, Money Order, or Certified Check. Freight additional. Indiana residents add 4% sales tax.

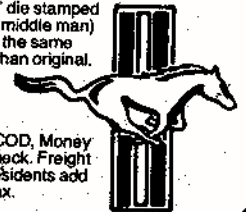

Specify Driver or Passenger side on all orders.

the paddock
SPORTSCAR SPECIALISTS

THE PADDOCK, 38 W. Warrick St., Knightstown, Indiana 46148
ORIGINAL REPRODUCTIONS IN STEEL BODY PANELS

317 345-2984

SUPER FORD

PARTS EXCHANGE

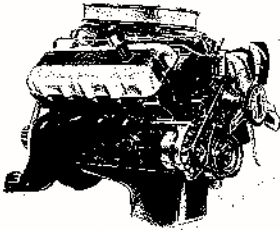

Devoted exclusively to FORD and FORD related cars, parts, services, and literature.

Subscribe to a monthly magazine for FORD restoration and performance enthusiasts. Find illustrated engine articles, Collector Series sketches and articles on all the "Super Fords", information of coming events, a Readers' Cars section, Book Reports on other Ford related publications, a Questions and Answers section, our exclusive Rodder's section, listings of hundreds of performance and restoration parts from dealers and individuals all over the world, and much, much, more!!

Only \$8.00 for 1 year subscription (12 issues). Outside U.S. \$10.50 (at U.S. exchange). Subscribe now - New Subscribers get two 50 word classified ads FREE! THE SUPER FORD PARTS EXCHANGE, T-110 Ovid St., Seneca Falls, N.Y. 13148.

MUSTANG PARTS AT DISCOUNT

Genuine fresh new Ford stock, we allow a 20% discount from Ford list prices. Listed below are a few examples... we pay shipping charges.

	LIST	OUR PRICE
1965/70 rear bumpers,	\$62.50	\$50.00
1965/70 front bumpers,	62.50	50.00
1965/68 front fenders,	106.60	85.50
1969/70 front fenders,	108.20	86.50
1965/66 rear quarters,(F63)	136.50	109.25
1965/66 rear quarters(F65)	116.55	93.25
1965/66 rear quarters (F76)	116.55	93.25
1967 L.H. rear quarters (F63)	136.50	109.25
1967 Rear Quarters (F65)	116.55	93.25
1965/70 inner wheelhouse	33.90	27.15
1965 padded dash, black, red, blue	93.90	75.12
1966 padded dash, black, burgandy, blud	93.90	75.12
1969/70 padded dash pads, black only. Can be dyed	134.80	108.00
1965/68 front valance	36.50	29.35
1965/68 rear valance	28.10	22.50

All Mustang parts that we can secure from Ford, discounted 20% from List Prices, plus a \$3.00 per order packing charge. WE PAY SHIPPING COSTS. Send us your list of needs (complete part numbers please for quote. Send S.A.S.E. We offer the same deal on all Ford product parts 1948 through 1978.

Bob Cook
Dealer-Collector
Box 104 - Hazel, Kentucky 47049

NOW AVAILABLE!



'65 MUSTANG GAS CAP

with wire. An exact reproduction. Only \$29.95 + 10% shipping. Use your BAC/VISA or Mastercharge

CALL TOLL FREE 800-854-0393

in California call 714-992-4781

LARRY'S MUSTANG PARTS

511 SOUTH RAYMOND AVENUE
FULLERTON, CALIFORNIA 92631

10-79

the Paddock

FLASH!

NEW PADDOCK PATCH PANEL

"Inner"

lower rear

corner

NOW AVAILABLE

These have original
Factory impressions,
die stamped.

Order right or left
\$15 ea.

RESTORATION • OBSOLETE BODY PARTS • PATCH PANELS
38 W. WARRICK ST. KNIGHTSTOWN, IN 46148 (317) 345-2984

ORIGINAL MUSTANG TIRES

FOR

1964½ - 65 - 66 - 67 - 68

695x14

If you want your Mustang completely original from ground up—these are the tires.

Major brand—tread width—4½ ins—whitewall width ½ inch—size on sidewall 695x14—price (Fed tax included) **44.75** fob. 4% sales tax to NC residents.

VISA—MASTER CHARGE—CERTIFIED CHECK—MO

HALL TIRE & BATTERY CO.

919-275-3812

Greensboro

2222 Asheboro St

919-275-4778

"The Tire Doctors"

11-79

NC 27406

MUSTANG

SPOILERS • FIBERGLASS • FLARES

'65-'70 Mustang, Mustang II Spoiler and 4 Flare (All 5 pieces as pictured) \$99

SUPER QUALITY

SUPER PRICES!

FLARES

SHIPPED THE DAY YOU ORDER!

Price per Pair	Fl.	Fl.	Fl.	Fl.
\$2.50	Camaro	\$49	\$49	64-70 Mustang
1968	Camaro	59	69	73-78 Firebird
70-74	Camaro	49	69	All Bronco
65-74	Corvette	59	69	73-78 Blazer
68-74	Nova	49	59	All Pinto
67-68	Firebird	49	49	All Vega
1969	Firebird	59	69	73-78 Chev P.U.

Specify make, model & year of car. Send 50% deposit (money order) with order to:

racing unlimited

DEPT. 2607 HENNEPIN AVE.
MPLS., MN 55405 (612)377-6701

FUZZY DICE

From the 50's!

\$3.95 Per pair/
+50¢ postage

• Free Catalog •

SAVING ALL THE COLOR!
11-100 Black-White Dice
11-101 Blue-White Dice
11-102 Green-White Dice
11-103 Red-White Dice
11-104 Yellow-White Dice
11-105 Orange-White Dice
11-106 Purple-White Dice
Free color catalog! (Handbook of dice, and more, inside!)
S&W 2002 HENNEPIN, DEPT. 2607, MINNAPOLIS, MN 55405
—SEE YOUR LOCAL STORE

MUSTANG



289-302 Cobra Aluminum Valve Covers . . . pr.	\$39.95	1965 "260" Emblem Ea.	\$8.00
1965 Mustang 14" Full Wheel Cover Ea.	\$11.95	1965/66 "High Performance" Emblem Ea.	\$8.00
1966 Trim Ring for Styled Steel Wheel Ea.	\$15.00	1965 Qtr. Panel Ornament Ea.	\$9.50
1965/66 Red Center for Styled Steel Wheels Ea.	\$5.95	1966 Qtr. Panel Ornament Ea.	\$10.50
1965/68 Chrome Lug Nuts For Styled Steel Wheels Ea.	\$1.25	1965/66 or 1967/68 Front Fenders Ea.	\$89.00
1965/66 Horn Ring for Std. Steering Wheel	\$26.50	1965/66 or 1967/68 Bumpers Ea.	\$48.95
1965/67 Horn Ring for Woodgrain Wheel	\$14.50	1965/66 Bumper Guards (Set of 4)	\$40.00
1965/66 GT Exhaust Trumpets Pr.	\$50.00	1965/66 or 1967/68 Front Valance Panel	\$36.50
1965/66 GT or Std. Rear Valance Panel	\$28.00	1965/66 Dash Bezels (Specify yr. and type)	\$17.50
1965/67 Radiators (specify yr. and engine)	\$100.00	1967 GT Dash Bezel (Brushed Aluminum)	\$27.50
1965 Grille Ornament "Horse & Corral"	\$34.50	1967 Std. Dash Bezel (Black)	\$15.00
1966 Grill Ornament "Horse & Corral" (std.)	\$28.50	1968 Dash Bezel (Black)	\$27.50
1966 Grill Ornament "Horse & Corral" (GT)	\$34.50	1965 Speedometer-Rectangular 120 mph	21.00
1967 Grill Ornament "Horse & Corral"	\$28.50	1965/66 Speedometer-Round 140 mph	\$21.00
1965/68 Fuel Tank, (16 Gal.)	\$57.00	1967/69 Speedometer W/D Trip Odometer	\$23.50
1965/66 Battery Tray	\$5.00	1965/66 Taillamp Bezels Ea.	\$8.00
1967/68 Battery Tray (45 Amp Battery)	\$10.50	1967/68 Taillamp Bezels (6 Req'd.) Ea.	\$7.50
1965 "Mustang" Nameplate 4 1/2" (with generator) Ea.	\$3.50	1965/66 Parking Lamp Ass'y. Ea.	\$12.00
1965/66 "Mustang" Nameplate 4 7/8" (with alternator) Ea.	\$5.00	1967/68 Parking Lamp Ass'y Ea.	\$13.00
1965/66 "Mustang 2 + 2" Nameplate Ea.	\$7.50	1965/66 Back-Up Lamp Ass'y. Ea.	\$11.50
1965/66 "GT" Emblem (ceramic type) Ea.	\$11.00	1967/68 Back-Up Lamp Ass'y. Ea.	\$11.50
1966 "GT" Emblem (plastic type) Ea.	\$5.00	1965/66 Outside Door Handles Pr.	\$15.00
1965/66 "289" Emblem Ea.	\$5.50	1967/68 Outside Door Handles Pr.	\$18.00
Accessory Pony Mats (Red, Burgandy, white, Blue, Black, Green, or Brown) Set of 4	45.00	1965/66 Armrest Pads (Specify Color) Ea.	\$10.00
Front Only	\$30.00	1965/66 Armrest Bases (Chrome) Ea.	\$9.00
		1967 Armrest Pads (Black, Blue, Red) Ea.	\$15.00
		1968 Armrest Pads (Blue, Aqua, Green, Saddle) Ea.	\$15.00
		1965/66 Trunk Mats (Specify yr. and body type)	\$21.50
		1966 Shop Manual	\$19.95

We pay all shipping charges to 48 states and we will ship via UPS when possible. We respectfully request that orders under \$10 please add \$1 handling. Master Charge and Visa accepted or phone (606) 787-5031 to order COD. Our new 1965 to 1968 Mustang Catalog \$2, or free with any purchase. Satisfaction guaranteed!



PLEASE INCLUDE ALL
CARD NUMBERS.

The Ford Parts Warehouse
Courthouse Square
Liberty, Ky. 42539
606-787-5031

NOW SHIPPING

MUSTANG Does It!

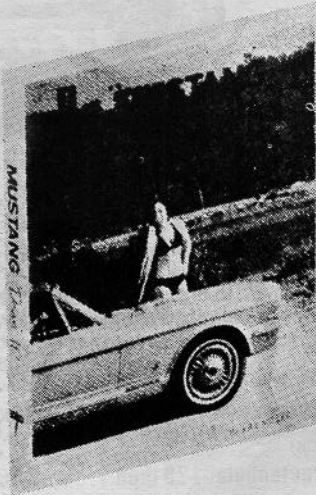

Note: Master Charge customers must furnish all the numbers — account, bank and expiration. Failure to do so will delay your order.

an illustrated history of Ford's pony car

Covers the Ford Mustang from inception through the 1973 models
Includes the interesting SHELBY-AMERICAN models from 1965-1970

320 pages; over 1300 crisp new photos and illustrations, many in full color

Hard cover; colorful protective dust jacket; library-bound for durability

A fine reference book, an excellent photographic record, and an interesting addition to your automotive library

\$24.95

each plus \$1.00 per order for handling and shipping.
Sorry, California residents must add \$1.50 tax

#6 in
The

Ford Rd

SERIES

The Evergreen Press

Box 1711, Oceanside, California 92054.

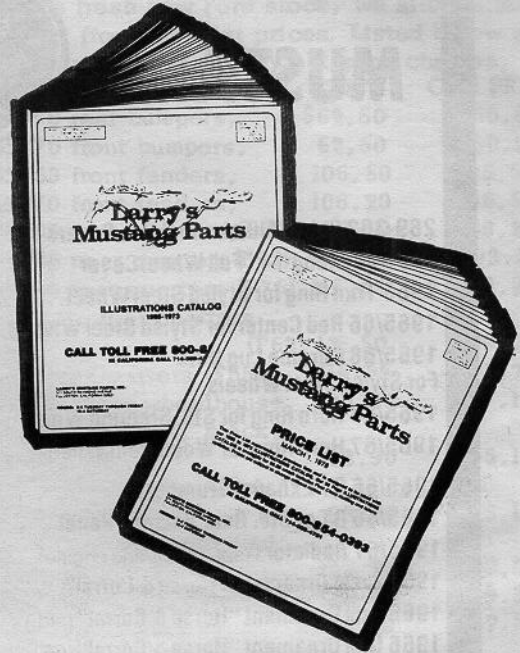

MUSTANG CATALOGS

Send for our comprehensive 92 page Illustrated 1965-1973 Mustang Parts Catalog. \$5.00 includes Catalog and Illustrated Price List, First Class Mailing and all future updates. Just charge it to your BAC/VISA or Master Charge.

PHONE TOLL FREE 800-854-0393

In California call 714-992-4781

**NEW & USED PARTS
AUTHENTIC UPHOLSTERY**

**Larry's
Mustang Parts**

**511 S. RAYMOND AVE.
FULLERTON, CA 92631**

10-79

classified advertising

CLASSIFIED ADS ARE FREE TO MEMBERS. NON-MEMBERS 10¢ PER WORD. MEMBERS ARE LIMITED TO THREE (3) FREE ADS PER MONTH WITH A COMBINED TOTAL NOT TO EXCEED 150 WORDS OR 50 PER EACH AD. FREE ADS ARE LIMITED TO THREE CONSECUTIVE MONTHS.

FOR SALE:
Muscle Parts Catalog supplement #1 or #2. These are NOS in mint condition \$15.00 each PPD. Mustang Parts, Inc., P.O. Box 548, Lithonia, Ga. 30058.

FOR SALE:
1965-66 outside remote-control L/H mirrors, NOS in original boxes. Complete \$50.00 each. Add 10% shipping. Georgia Mustang, Inc., P.O. Box 254, Redan, Georgia 30074

FOR SALE:
1964 Mustang coupe NOS postcards. Very rare...showing gold 6-cylinder coupe with the words "'64 Mustang". Very limited quantities. Mustang Parts Inc., P.O. Box 254, Lithonia, Ga. 30058.

FREE!!!!
Send large SASE for our new Mustang Parts catalog. Georgia Mustang, Inc., P.O. Box 254, Redan, Georgia 30074 (404) 482-6943.

FOR SALE:
1970 Ford Mustang Grande. One-owner California car. Very good condition. Only one driver in 8½ years. 351-4V engine, air, AM/FM stereo, tilt-steering wheel, wire wheel covers, burnt orange with white mini-top on front rather than rear. Very rare. Barbara Schults, 5102 Harvard Avenue, Westminster, Ca. 92683 (714) 892-7227.

FREE!!!!
Send large SASE for free Mustang decal and detailing list. Mustang Parts, Inc., P.O. Box 548, Lithonia, Ga. 30058.

Super Discount Quality T-Shirts

SHELBY "Great Christmas Gifts"
1st Line Prints with Durable Rubber Ink (Not an Iron-On Transfer)
Assorted Colors
(All Shirts Hand Picked Irr.)
Please give 2nd color choice when ordering shirts.

We Also Print Custom T-Shirts, Clubs, etc.
"If You Don't See It, Ask For It"
If we don't have it, we will gladly refund your money.
"We Have Over 100 Designs"

Mustang Designs Available:

M1 - Mustang Emb.	M2 - 65 2 Plus 2	M3 - 65 Conv.
M4 - 68 Fastback	M5 - Mach 1 69	M6 - Boss 302
M7 - Boss 351	M8 - Boss 429	M9 - Cobra-Car GT
M10 - Cobra 427	M12 - Cobra Cobra	M13 - Cobra Emb.
M14 - Cobra-Jet	M15 - Cobra-Snake	M16 - Shelby "G"
M17 - Shelby GT500	M18 - Shelby KR500	
M19 - Shelby GT350	M21 - 78 Ford Cobra	

Price:
\$3.00 ea. or two for \$5.50

TAGS TAGS TAGS
Great Looking For Antiques or Classics
Baked White Both Sides
Printed With Durable Process Enamel.
Avail Designs

SUNBEAM TIGER
G.T. 350
BOSS 302

Light Wt. Aluminum

Price:
\$3.00 ea. or two for \$5.50

"AUTHORIZED SIGNS"

30 Ga. Metal, Baked White Enamel Both Sides, 12 x 12 - Punched Holes
Antique, Classic Cars
Great for Workshop, Business, Garage, Den, Bar or House!

2 Sides - \$6.00
1 Side - \$5.00 Avail. Same Designs As T-Shirts

AUTHORIZED SHELBY SALES-SERVICE-PARTS
AUTHORIZED HIGH PERFORMANCE FORD SALES-SERVICE-PARTS
AUTHORIZED MUSTANG SALES-SERVICE-PARTS

Quan.	Item No.	Description	Size	Price

Orders under \$20 add .65 Per Item; orders \$20 or more we pay shipping. Cash or M.O. for prompt shipment. Checks require 2 weeks minimum to clear. Canadian and all other foreign orders add \$2. COD orders add \$2 shipping.

Ship to: _____

ADDRESS _____ CITY _____ STATE _____ ZIP _____

VINTAGE TEES
P. O. BOX 233
JASPER, GA 30143

Signature _____

classified advertising

CLASSIFIED ADS ARE FREE TO MEMBERS. NON-MEMBERS 10¢ PER WORD. MEMBERS ARE LIMITED TO THREE (3) FREE ADS PER MONTH WITH A COMBINED TOTAL NOT TO EXCEED 150 WORDS OR 50 PER EACH AD. FREE ADS ARE LIMITED TO THREE CONSECUTIVE MONTHS.

PARTS FOR SALE:

Ford 260-V8 short block bored .030 over with new forged pistons, rings, stock camshaft, cam bearings, rods and rod bearings. All new parts, never run, has 5-bolt bell housing pattern. Sell in short block or complete trim - many more Ford engine parts. W. T. Pierce, 9512 Gregory Place, Charlotte, N.C. 78212 (704) 536-5021.

FOR SALE:

4 styled steel wheels, GT center caps and trim rings \$150. Pair Underrider Traction Master traction bars for 65-66 Mustang-Shelby \$25. 4 Fenton aluminum slotted mags for Mustang "4 lug" with nuts and caps \$100. (215) 495-6134. NO COLLECT CALLS!

FOR SALE:

1965 Mustang convertible 289-3 speed transmission, rebuilt motor, new top, new interior, new paint. Less than 500 miles since restoration. Restored for my use; however, circumstances have changed. I will sell to best offer. John Hess, 3049 Hidden Drive, Lawrenceville, Ga. 30245 (404) 921-7322.

WANTED:

1965-66 Mustang convertible, rust free, automatic transmission, V8, white top, light exterior paint, light interior (NO black), Would like Rally-Pac, Pony interior and air. Will pay over \$4,000. Bud Woodward, 521 East Piping Rock Road, Phoenix, Arizona 85022 (602) 866-0157.

FOR SALE:

1964½ - 65 or 1966 Mustang wiring diagram manuals. Your choice \$5.00..ppd. Mustang Parts, Inc., PO Box 548, Lithonia, Georgia 30058.

FOR SALE:

1966 Mustang coupe 289 automatic, Style Steel wheels, complete restoration. 1st Place 1978 Grand National class winner. (404) 448-5938 (home) or (404) 449-9069 (work). Terry.

FOR SALE:

Mustang Patches: 3" round \$2; 4" round, \$2.50; 5" round, \$3; Cobra 3" round, \$2; GT 350 3" round, \$2; Cobra-power square patch, \$2.25. Mustang small rec. \$2; Mustang back patch, \$3. All patches are postpaid. Georgia Mustang, Inc., PO Box 254; Redan, Georgia 30074.

FOR SALE:

1969 Mustang Mach I. Started restoration. 428 SUPER Cobra Jet, rebuilt..only has 800 miles on it...Many new parts. \$4,000 invested. Will sell for \$2,500. Call (404) 448-7606 days..(404) 876-4203 after 6 p.m.

FOR SALE:

1965-66 Mustang complete power system for convertible top. Two hydraulic units motor and pump, lines, wire and switch. Everything needed to make manual conv. top a power-driven system. Used-excellent. \$75.00 plus shipping. Jack Cornely, 504 Green Forest Drive, Severna Park, Maryland 21146 (301) 647-0628.

FOR SALE:

'65 Mustang hardtop GT with factory hi-performance engine. Genuine K-model, 1 owner, original title, original paint, style wheels, very small amount of rust. One of first GT's produced. Manufacture date 3/26/65. \$2,000 firm. Mark Hiatt 45 Sharon Drive, St. Charles, Mo. 63301. (314) 946-5009.

FOR SALE:

1973 Cougar XR-7, convertible, never wet since 1974, 18,000 miles, 351-4V, automatic, air, stereo, tilt wheel, powder blue. \$5,900. L. J. Graser, 1418 Forester, Oregon, Ohio (419) 698-3024.

FOR SALE:

1970 Boss 429, Grabber Blue w/black interior. Car is completely stock and absolutely flawless inside and out. Car is pictured in October issue of The Super Ford Parts Exchange. \$8,500 or best offer. (817) 379-5075 after 6 pm.

classified advertising

CLASSIFIED ADS ARE FREE TO MEMBERS. NON-MEMBERS 10¢ PER WORD. MEMBERS ARE LIMITED TO THREE (3) FREE ADS PER MONTH WITH A COMBINED TOTAL NOT TO EXCEED 150 WORDS OR 50 PER EACH AD. FREE ADS ARE LIMITED TO THREE CONSECUTIVE MONTHS.

FOR SALE:

1965 convertible, 200 CID, 3-speed, factory air, deluxe Pony interior, dlxe. spinner caps, new top, excellent running condition--new brake system (shoes, wheels, and master cylinders, hoses), shocks, water pump and hoses, wheel bearing bearings, exhaust system, alternator & regulators, and many other parts replaced, \$2,500. R. C. Blanchard, 921 Etna Drive, Newport News, Va. (804) 877-7006.

WANTED:

Need BOLT ASSEMBLY & BRACKETS which will mount to fog-lite assembly on grill. Have many parts to trade. Jack Waters, 476 St. Davids Avenue, Wayne, Pa. 19087. (215) 688-0169.

"MUSTANG MADNESS" Newly reproduced 289 engine dress-up kits. Reproduction of the accessory kit shown on P. 24 of '66 accessory catalog. Chrome: Oil, radiator caps, dipstick, master cylinder cap, Hi-Perf. type air cleaner and Finned aluminum COBRA valve covers. \$89.95. Without master cylinder cap for discs \$74.95. Mike Hufnagle, 103 E. 7th Ave., York, Pa. 17404 (717) 843-3964.

FOR SALE:

Let's get acquainted with the new kid on the block! '65-'66 Mustang padded dash, red, black blue or burgandy and instrument bezel..std. or woodgrain new Ford stock...\$88.50 for both including shipping. Maryland Mustang, 504 Green Forest Drive, Severna Park, Md. 21146 (301) 647-0628.

PARTS FOR SALE:

(4) 1966 Mustang factory AM-FM radios. Excellent playing condition. \$375.00 ea. Mark Hiatt, 45 Sharon Drive, St. Charles Missouri 63301 (314) 946-5009.

WANTED:

Roof console for 1968 Mustang GT fast-back. Prefer blue with artificial wood-grain. Must be for 1968. Contact: Tom Krakowiak, 300 South Parkway, Prospect Heights, Illinois 60070.

WANTED:

Front ashtray for 1970 Mustang w/brown interior. Call collect (803) 794-5739 or write: Benjamin O'Connor, 202 Branham Street, W. Columbia, S. C. 29169

FORD FANS! Subscribe to a monthly magazine devoted exclusively to Ford cars, parts, services and literature. One year (12 issues) only \$8. Do it now! THE SUPER FORD PARTS EXCHANGE, T-110 Ovid Street, Seneca Falls, N. Y. 13148

PARTS FOR SALE:

Mustang license plate frames \$4.75 ea; \$8.00 pair PPD, "Boss 302" license plates \$4.00 each, \$7.00 pair PPD. Mustang key fobs \$2.00 each, 3/\$5.00 PPD Beverly Hills car covers 65-73 Mustang \$66.00 PPD. All types air cleaner, valve cover, under hood, etc. detailing decals. Write your needs, Gowin Auto Parts, PO Box 298, Rocky Face, Ga. 30740. See us at Eastern National Meet in Chattanooga.

FOR SALE:

1966 Mustang convertible in Emberglow. Deluxe Pony interior .. in very nice condition .. has reconditioned AM-8 Track, power top. Call Steve Kirk, Columbus, Ohio (614) 235-7123.

WANTED:

Inner, outer, rain gutter trim NEW for '65 2+2, both sides; ALSO Shelby convertible, must be complete, authentic, rough and reasonably priced. Prefer running condition. Will consider basket cases or minor wrecks. John Amarilios, Box 28, New Canaan, Ct. 06840. Call (203) 966-8781 9-5 days.

FOR SALE:

1970 Boss 302, yellow, fresh engine, new paint, BFG radial T/A tires mounted on ET spokes. Nice car \$3,500. Bill Gowin, P.O.Box 298, Rocky Face, Ga., 30740 (404) 673-2879. We also have several other Boss cars needing various repairs to choose from. See me at Eastern National Meet in Chattanooga.

classified advertising

CLASSIFIED ADS ARE FREE TO MEMBERS. NON-MEMBERS 10¢ PER WORD. MEMBERS ARE LIMITED TO THREE (3) FREE ADS PER MONTH WITH A COMBINED TOTAL NOT TO EXCEED 150 WORDS OR 50 PER EACH AD. FREE ADS ARE LIMITED TO THREE CONSECUTIVE MONTHS.

FOR SALE:

65-66 Mustang Running Horse trunk and ignition key blanks. NOS nickel-plated brass. \$1.00 per key with SASE. Lee E Kitchens, 351 Buttonwood Lane, Cinnaminson, N.J. 08077.

WANTED:

289 "COBRA" aluminum oil pan and intake manifold, also chrome moulding for front of console with air cond. I am also interested in any hard-to-find NOS or used parts you have to sell or trade, especially NOS. Mike Hufnagle, 103 E. 7th Ave., York, Pa. 17404 (717) 843-3964.

FOR SALE:

Several 65-66 GT lite bars. Complete \$200.00 each. Lots of used GT parts and other hard-to-find Mustang items. Call or write: Mark Kiatt, 45 Sharon Dr., St. Charles, Mo. 63301 (314) 946-5009.

PARTS FOR SALE:

Car covers, Beverly Hills "BLUEGUARD" fabric custom fit for 65-73 Mustangs \$66.00 PPD. Gowin Auto Parts, PO Box 298, Rocky Face, Ga. 30740. See us at Eastern National Meet in Chattanooga.

WANTED:

2-14" Magnum 500 wheels with or without trim rings or center caps. Must be good condition, no rust. Larry Wilson, Rt. 2, 121 Deerfield Road, East, Bloomingdale, Georgia 31302 (912) 748-7146.

FOR SALE:

"MUSTANG MADNESS" Engine Dress-up goodies: Chrome: Oil cap \$3.50, radiator cap \$2.95; master cylinder cap, std. brakes \$14.95; dipstick \$9.95, Hi-Performance type air cleaner w/element \$21.95. Finned aluminum "Cobra" valve covers \$39.95 pair. Add 10% shipping. Mike Hufnagle, "Mustang Nut", 103 East 7th Ave., York, Pa. 17404 (717) 843-3964.

FOR SALE:

1965 Mustang convertible 6-cylinder, automatic, power steering, Pony interior new top. Call Terry: (404) 448-5938 home or (404) 449-9069 work.

FOR SALE:

Become a Mustang overnight. I'm selling out! 1965 convertible. Two 1966 convertibles. 1965 fastback. 1965 coupe. Three 1966 coupes. 1967 coupe. 1968 coupe....Plus \$7,500 in parts. ALL for \$16,500. SASE plus \$1.00 for information. \$1.50 for each photo. Jim Fears, 2454 Southwood, Dallas, Tx. 75233. (214) 339-9637.

PARTS FOR SALE:

65-66 Mustang Parts-miscellaneous, wide selection, old & NOS. Call for your parts needs and very reasonable prices. Steve Kirk, Columbus, Ohio (614) 235-7123.

FOR SALE:

1969-73 air cleaner decals: 429-4V; Ford 302 Boss; Ford 302-4V Premium fuel; Ford 302-2V regular fuel; Ford 351-4V premium fuel; Ford 351-2V regular fuel; 351 C.I.D. Ram Air; Cobra Jet Ram Air; all above decals \$2.50 each PPD. Georgia Mustang, Inc. P.O. Box 254, Redan, Georgia 30074.

FOR SALE:

1970 Boss 302, completely restored with NOS parts, including all new sheet metal-many parts no longer available. Beautiful blue with mint black interior...all original engine \$8,000 invested. Make offer. Call Steve Kirk, (614) 235-7123; Columbus, Ohio.

WANTED:

For a 1969 Mach I: 428 CJ, black interior. Original tailpipes, seat covers, carpet, rear seat arm rests, door panels, aluminum manifold. Jay Harper, 606 Olive, Sandpoint, Idaho 83864. (208) 263-2873.

PARTS FOR SALE:

Disassembled T10-H1-W1-H29 and T10-H1-W1-L5 transmissions both jumped out of gear both for \$45. Hurst competition plus shifter for T-10 good condition \$35.00. Very good set of black Pony seats - 1966 coupe \$50.00. Good 1967 GT foglite assembly without lights \$145.00. F.O.B. prices. Gordon Smith, P.O. Box 72, Avon Park, Florida 33825. (813) 453-7207 NO COLLECT CALLS!

PLEASE RUSH TO

FROM
NATIONAL HEADQUARTERS
THE MUSTANG CLUB OF AMERICA, INC.
P. O. BOX 447
LITHONIA, GEORGIA 30058

FIRST CLASS
MAIL
U.S. Postage
PAID
Avondale Estates,
Georgia
Permit No. 170

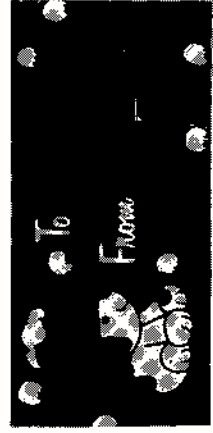

1971



1973



1972



1970

DEDICATED TO THE PRESERVATION, CARE, HISTORY AND ENJOYMENT OF

May the joys **MUSTANG - SHELBY** *of the Holiday Season,*

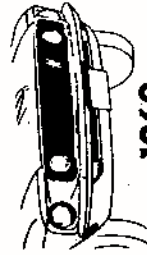

1969

be yours to share

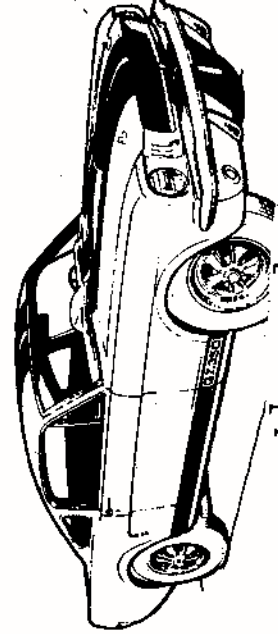

throughout



1965



1967

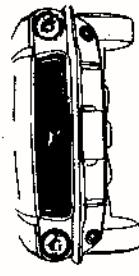

1968

the New Year



1966