

Vehicle (Year/Make/Model) '07 Five Hundred/Freestyle/Montego	
Equipment or Trim level ALL	System(s) applicable to: RKE/VSS/RMST
Page 1 of 4	Revision Date 8/18/06

Module:
PC-34
7L3Z-19G367-AA

FUSE PLACEMENT CHART

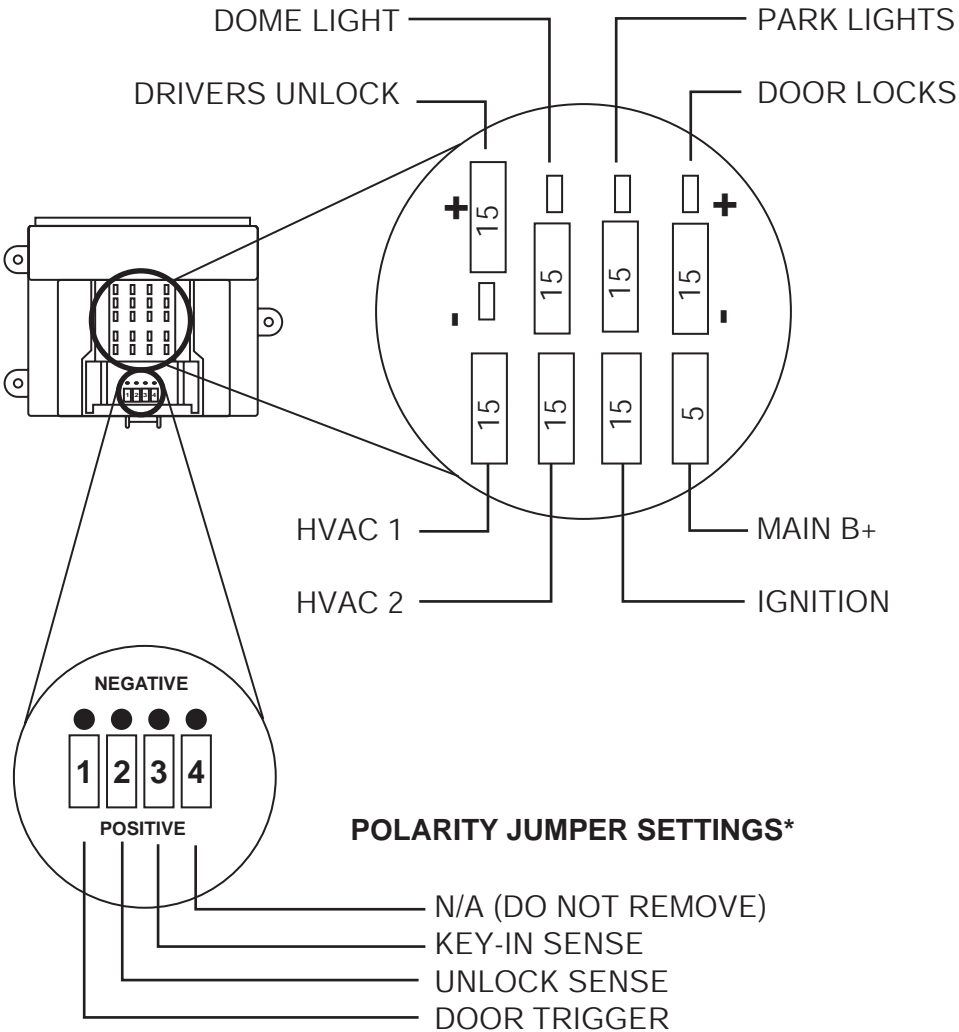

* See Polarity Jumper Section in Base Instructions for details

PARTS REQUIRED:

RKE/VSS/RMST Kit:
7L3Z-19G364-AA

Securilock (PATS) Interface:
PIK-4 (P/N: 7L2Z-19G365-AA - order separately)

FUNCTIONAL PROGRAMMING REQUIREMENTS

BANK	OPTION	DESCRIPTION	LED
1	1	LITE TOUCH ADJUSTMENT	note 1
1	2	FULL SHOCK ADJUSTMENT	note 1
1	4	DOOR AJAR INVERT	ON
1	5	UNLOCK SENSE INVERT	ON
1	6	KEY-IN SENSE INVERT	ON
2	1	STARTER INTERRUPT	OFF
2	8	DRIVER UNLOCK RELAY	note 2
3	1	DRIVER PRIORITY UNLOCK	note 2
4	1	TACHLESS MODE	ON

Note 1: Perform proper adjustments per the "Shock Sensor Setting" section of the Base instruction sheets.
Note 2: See the Optional Connections / Features page

MODULE MOUNTING LOCATION:
Left Side of Driver's Underdash

Vehicle (Year/Make/Model)	
'07 Five Hundred/Freestyle/Montego	
Equipment or Trim level	System(s) applicable to:
ALL	RKE/VSS/RMST
Page	Revision Date
2 of 4	5/3/06

DRIVER'S SIDE KICK PANEL HARNESS

	Color	Function
A-5	BLACK	Ground
C-12	GREEN/WHITE	Memory Seat 1 Output
C-13	YELLOW/GREEN	Memory Seat 2 Output

MAKE THIS CONNECTION FIRST!

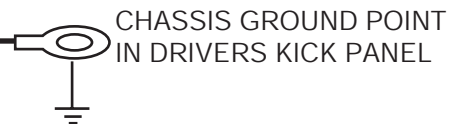

Optional Installation Feature see
Optional Connections page 4 of 4

STEERING COLUMN HARNESS

	Color	Function
A-4	RED	Battery
B-2	RED	HVAC1 Battery Feed
A-7	PINK	Ignition 1 Input/Output
B-4	ORANGE	HVAC1 Output
B-8	BLACK/WHITE	Key-in-sense Input
A-8	VIOLET	Starter Output
A-21	BROWN/BLACK	Horn Relay Output
B-7	BROWN	Brake Input
A-20	GREEN/VIOLET	Door Ajar Switch Input
C-11	BLUE/WHITE	Rear Defroster Output

MAKE THIS CONNECTION LAST!

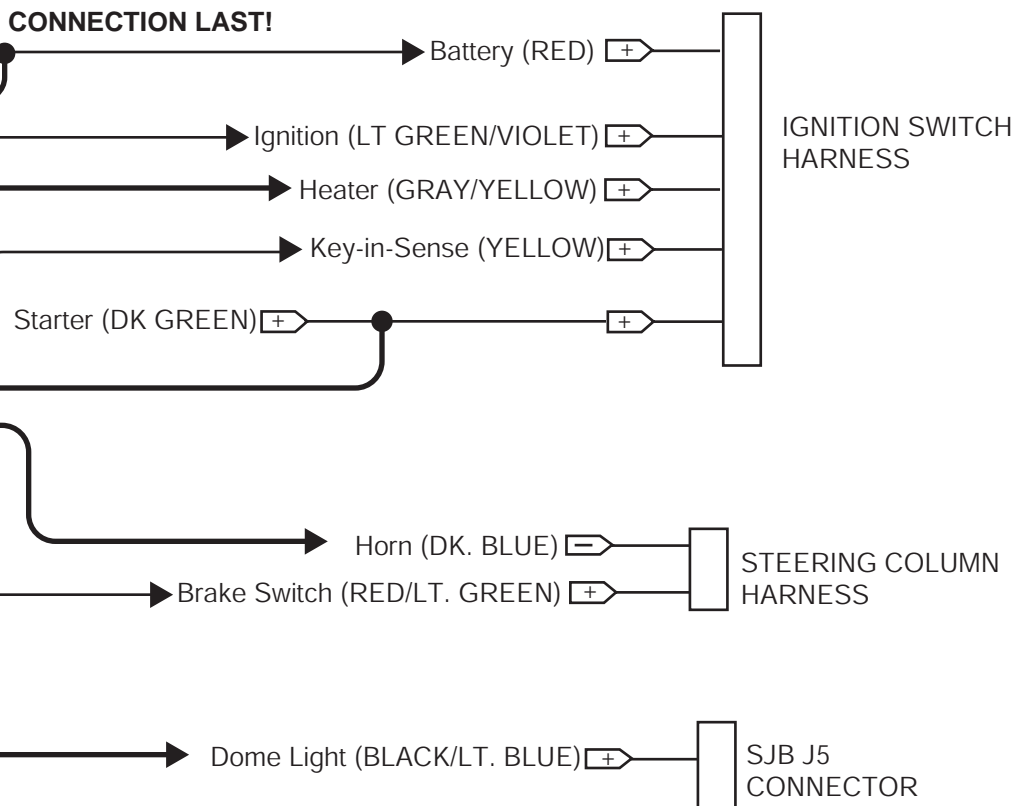

Optional Installation Feature see
Optional Connections page 4 of 4

See "SJB Layout" page for
connector locations.

Vehicle (Year/Make/Model)	
'07 Five Hundred/Freestyle/Montego	
Equipment or Trim level	System(s) applicable to:
ALL	RKE/VSS/RMST
Page	Revision Date
3 of 4	5/3/06

HEADLAMP SWITCH HARNESS

	Color	Function
A-1	WHITE	Parking Light Output
A-3	BLACK/WHITE	Dome Light Output
A-24	BLUE/GREEN	Trunk Release Output



KICK PANEL HARNESS

	Color	Function
A-12	LT. GREEN	Unlock Switch Sense Input
A-2	BLUE	Door Lock Output
A-14	GREEN	Door Unlock Output
A-11	WHITE/BLUE	Arm Input
A-9	BROWN	Disarm Input
C-4	LT.GREEN/BLACK	Factory Alarm Disarm
A-13	TAN	Driver Door Unlock Output

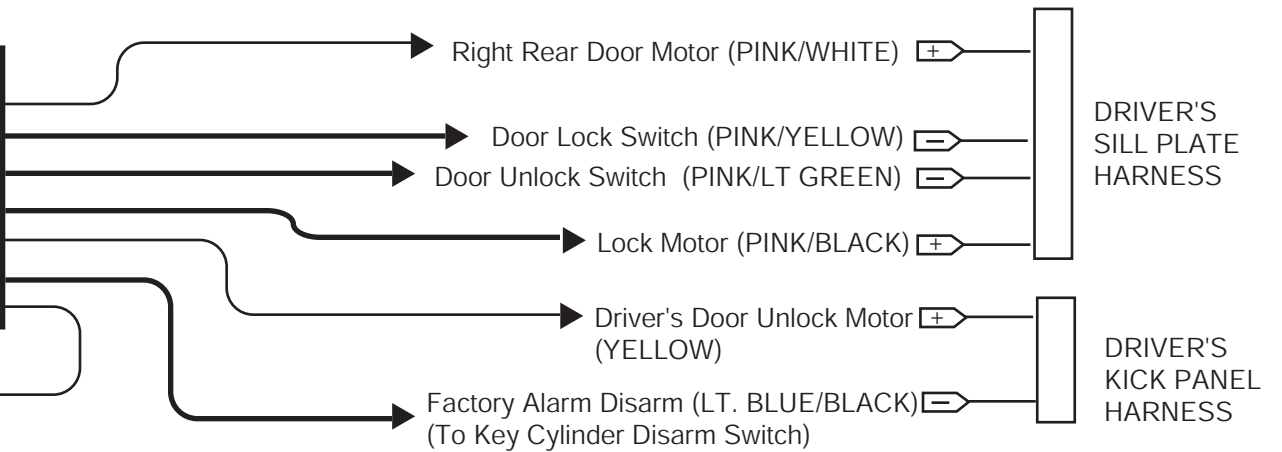

UNDERHOOD HARNESS

	Color	Function
A-19	GRAY	Hood Open Switch Input

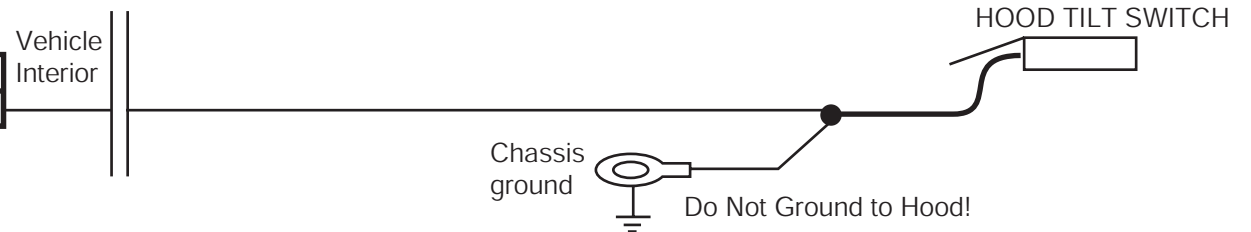

Vehicle (Year/Make/Model)	
'07 Five Hundred/Freestyle/Montego	
Equipment or Trim level	System(s) applicable to:
ALL	RKE/VSS/RMST
Page	Revision Date
4 of 4	5/3/06

OPTIONAL CONNECTIONS / FEATURES

OPTION PROGRAMMING REQUIREMENTS

BANK	OPTION	DESCRIPTION	LED
2	8	DRIVER UNLOCK RELAY	ON
3	1	DRIVER PRIORITY UNLOCK	ON

DRIVER'S DOOR PRIORITY UNLOCK

	Color	Function
C-9	TAN/RED	Driver Door Unlock Switch
A-13	TAN	Driver Door Unlock Motor
A-9	BROWN	Disarm Input

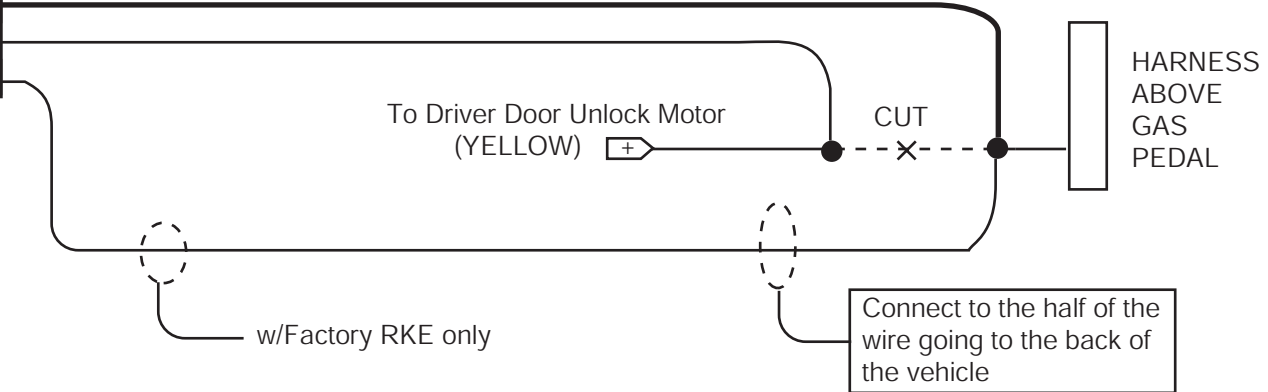

REAR DEFROSTER

	Color	Function
C-11	BLUE/WHITE	Rear Defroster Output



MEMORY SEATS

	Color	Function
C-12	GREEN/WHITE	Memory Seat 1 Output
C-13	YELLOW/GREEN	Memory Seat 2 Output

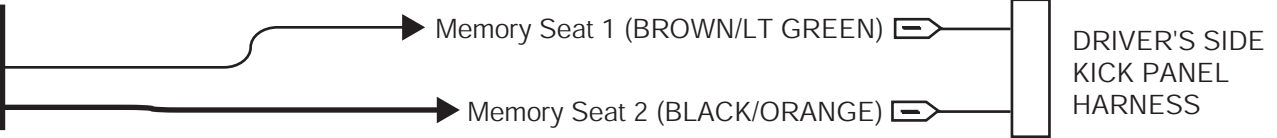

Vehicle (Year/Make/Model) '07 Five Hundred/Freestyle/Montego	
Equipment or Trim level ALL	System(s) applicable to: RMST
Page 1 of 2	Revision Date 8/18/06

Module:
PC-14
7L2Z-19G367-AA

FUSE PLACEMENT CHART

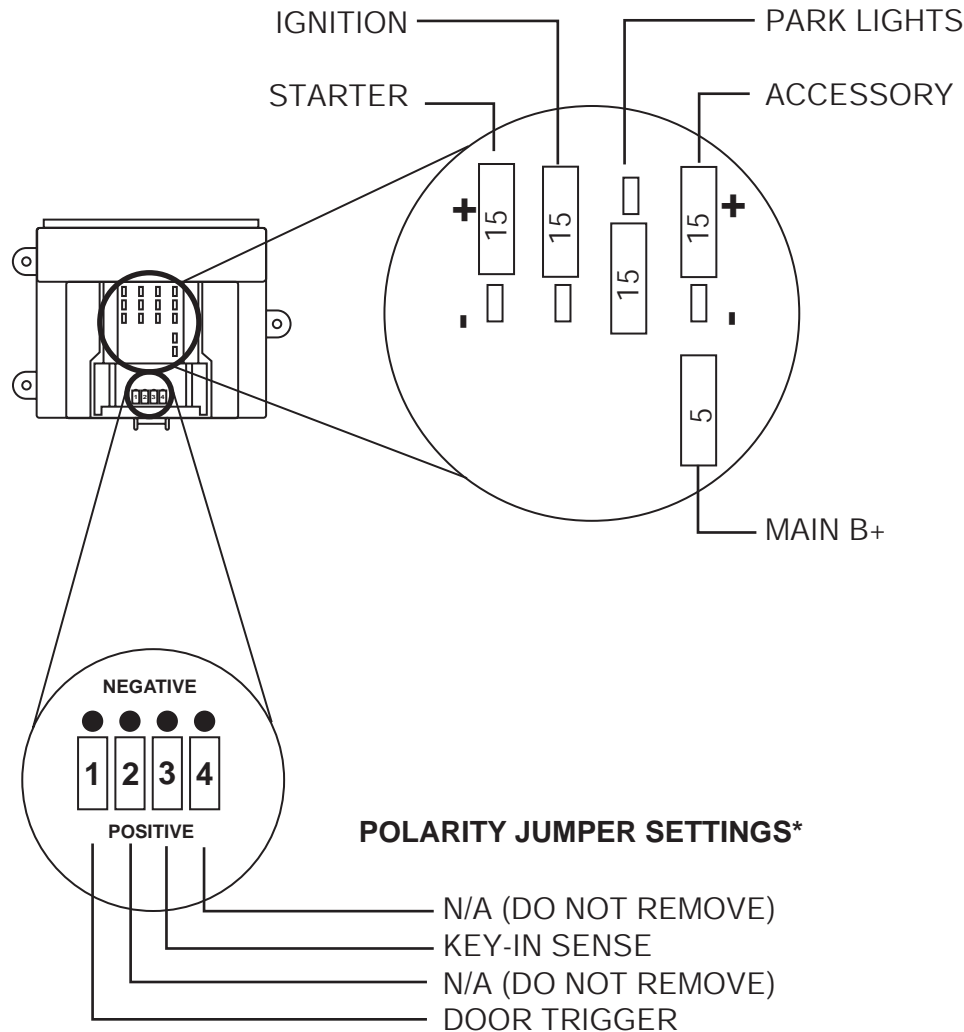

POLARITY JUMPER SETTINGS*

* See Polarity Jumper Section in Base Instructions for details

PARTS REQUIRED:

RMST Kit:
7L2Z-19G364-AA

Securilock (PATS) Interface:
PIK-4 (P/N: 7L2Z-19G365-AA - included)

FUNCTIONAL PROGRAMMING REQUIREMENTS

BANK	OPTION	DESCRIPTION	LED
1	2	DOOR AJAR INVERT	ON
1	3	KEY-IN SENSE INVERT	ON
2	1	TACHLESS MODE	ON

MODULE MOUNTING LOCATION:

Left Side of Driver's Underdash

Vehicle (Year/Make/Model) '07 Five Hundred/Freestyle/Montego	
Equipment or Trim level ALL	System(s) applicable to: RMST
Page 2 of 2	Revision Date 10/27/06

USE TYPE "A" CUSTOM WIRE HARNESS

VEHICLE HARNESS

IGNITION SWITCH

STEERING COLUMN HARNESS

	Color	Function
A-3	PINK	Ignition Input/Output
A-2	ORANGE	HVAC Output
A-13	VIOLET	Starter Output
B-8	BLACK/WHITE	Key-in-sense Input
A-4	RED	Battery

	Color	Function
A-21	BROWN/BLACK	Horn Relay Output
B-7	BROWN	Brake Input

DRIVER'S KICK PANEL HARNESS

	Color	Function
A-5	BLACK	Ground
A-24	BLUE	Door Lock Output
A-1	WHITE	Parking Light Output
A-20	GREEN/VIOLET	Door Ajar Switch Input

UNDER HOOD HARNESS

	Color	Function
A-19	GRAY	Hood Open Switch Input

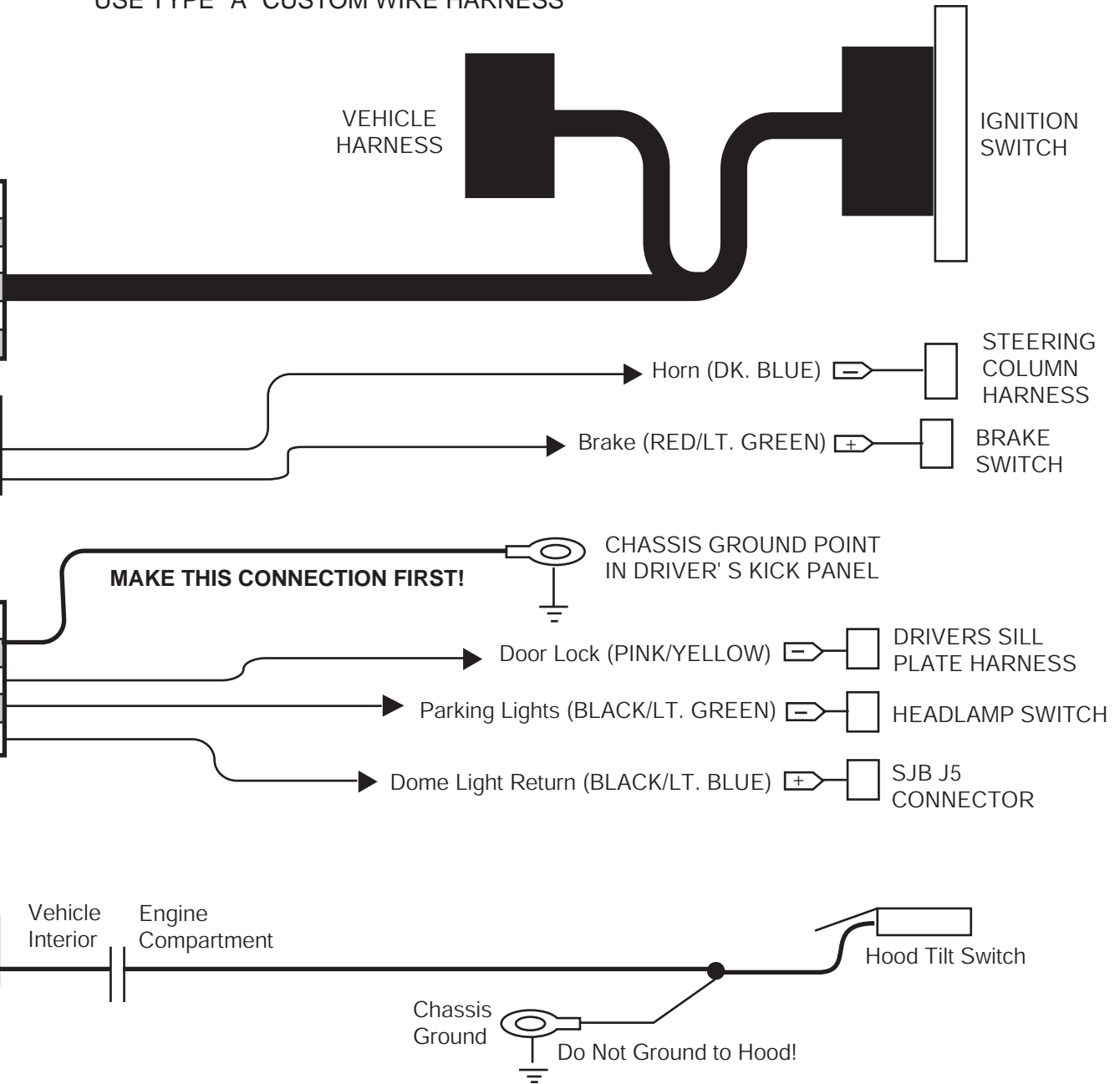

Vehicle (Year/Make/Model) '07 Five Hundred/Freestyle/Montego	
Equipment or Trim level ALL	System(s) applicable to: VSS
Page 1 of 2	Revision Date 10/27/06

Module:
PC-14
7L2Z-19G367-AA

FUSE PLACEMENT CHART

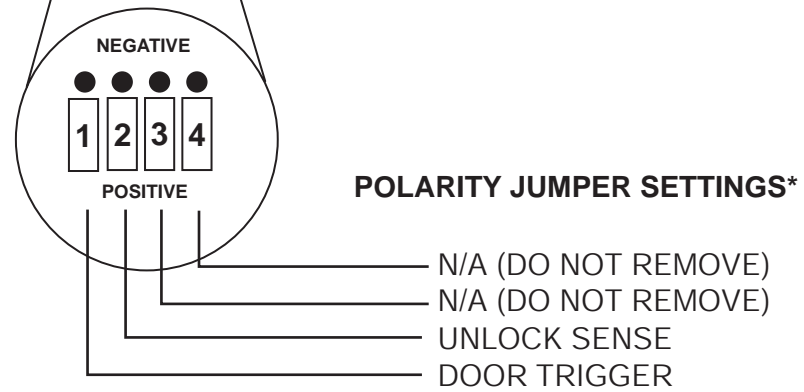
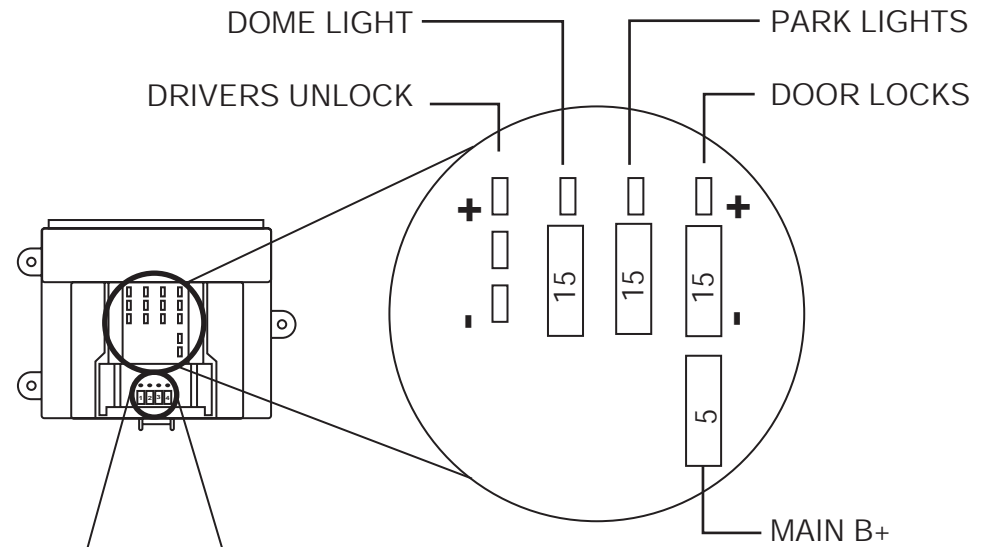

POLARITY JUMPER SETTINGS*

* See Polarity Jumper Section in Base Instructions for details

PARTS REQUIRED:

VSS Kit:
7L3Z-19A361-AA

FUNCTIONAL PROGRAMMING REQUIREMENTS

BANK	OPTION	DESCRIPTION	LED
1	1	LITE TOUCH ADJUSTMENT	note 1
1	2	FULL SHOCK ADJUSTMENT	note 1
1	3	DOOR AJAR INVERT	ON
1	4	UNLOCK SENSE INVERT	ON
2	1	STARTER INTERRUPT	OFF

Note 1: Perform proper adjustments per the "Shock Sensor Setting" section of the Base instruction sheets.

MODULE MOUNTING LOCATION:

Left Side of Driver's Underdash

NOTE:

IF USING THIS SYSTEM IN LOT MODE, WIRE HARNESS P/N 2W7Z-19C757-BA WILL HAVE TO BE ORDERED TO ACCESS THE 'FACTORY DISARM OUTPUT" WIRE (LT.GREEN/BLACK).

Vehicle (Year/Make/Model)	
'07 Five Hundred/Freestyle/Montego	
Equipment or Trim level	System(s) applicable to:
w/ Factory RKE	VSS
Page	Revision Date
2 of 2	5/3/06

DRIVER'S SIDE KICK PANEL HARNESS

	Color	Function
A-5	BLACK	Ground

STEERING COLUMN HARNESS

	Color	Function
A-4	RED	Battery
A-7	PINK	Ignition 1 Input/Output
A-8	VIOLET	Starter Interrupt Motor Side
A-6	VIOLET/RED	Starter Interrupt Key Side
A-21	BROWN/BLACK	Horn Relay Output
A-20	GREEN/VIOLET	Door Ajar Switch Input

See "SJB Layout" page for connector locations.

HEADLAMP SWITCH HARNESS

	Color	Function
A-1	WHITE	Parking Light Output
A-3	BLACK/WHITE	Dome Light Output

KICK PANEL HARNESS

	Color	Function
C-4	LT.GREEN/BLACK	Factory Alarm Disarm
A-2	BLUE	Door Lock Output
A-14	GREEN	Door Unlock Output
A-12	LT. GREEN	Unlock Switch Sense Input
A-11	WHITE/BLUE	Arm Input
A-9	BROWN	Disarm Input

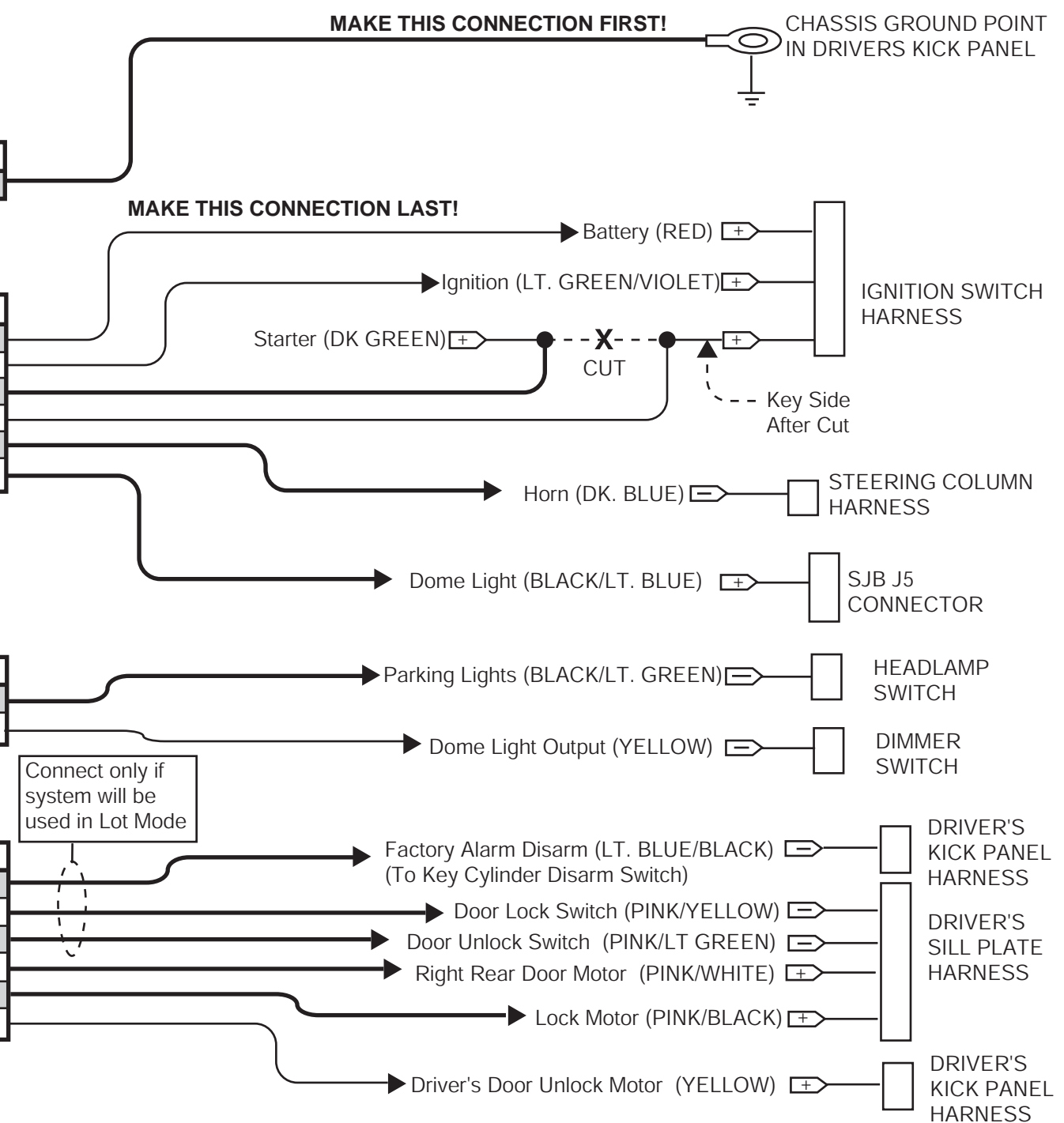

Vehicle (Year/Make/Model) '07 Five Hundred/Freestyle/Montego	
Equipment or Trim level ALL	System(s) applicable to: ALL
Page 1 of 1	Revision Date 5/3/06

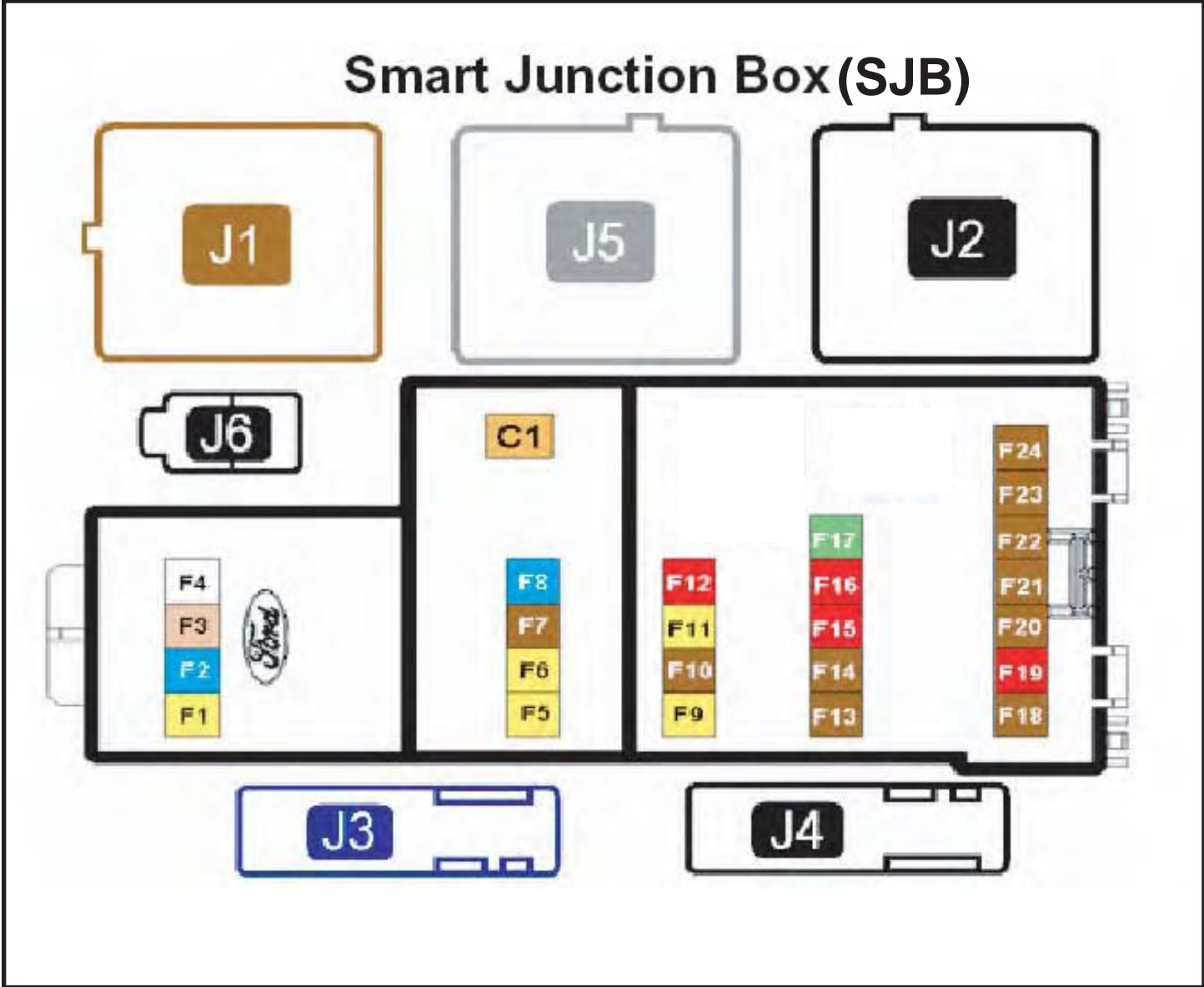

Location: Behind Driver's Side Lower Dashboard Panel

Vehicle (Year/Make/Model) '07 Focus	
Equipment or Trim level ALL	System(s) applicable to: RKE/VSS/RMST
Page 1 of 5	Revision Date 8/18/06

Module:
PC-34
7L3Z-19G367-AA

FUSE PLACEMENT CHART

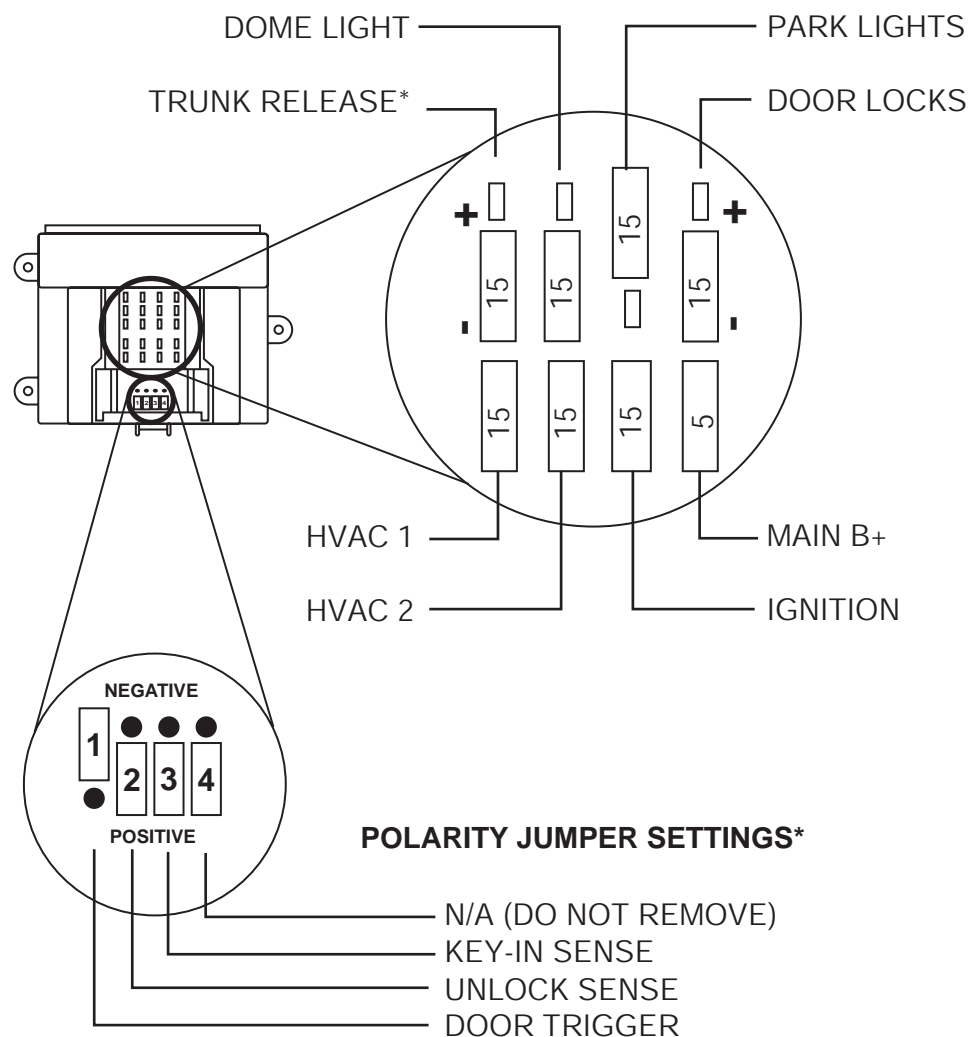

* See Polarity Jumper Section in Base Instructions for details

PARTS REQUIRED:

RKE/VSS/RMST Kit:

7L3Z-19G364-AA

Securilock (PATS) Interface:

PIK-4 (P/N: 7L2Z-19G365-AA - order separately)

RELAY REQUIREMENTS (P/N YL3Z-19G390-AA):

- 3- Power Window & Moonroof Interrupt Circuits
- 1- Headlights (optional)

FUNCTIONAL PROGRAMMING REQUIREMENTS

BANK	OPTION	DESCRIPTION	LED
1	1	LITE TOUCH ADJUSTMENT	note 1
1	2	FULL SHOCK ADJUSTMENT	note 1
1	4	DOOR AJAR INVERT	ON
1	5	UNLOCK SENSE INVERT	ON
1	6	KEY-IN SENSE INVERT	ON
2	1	STARTER INTERRUPT	OFF
2	8	DRIVER UNLOCK RELAY	note 2
3	1	DRIVER PRIORITY UNLOCK	note 2
4	1	TACHLESS MODE	ON

Note 1: Perform proper adjustments per the "Shock Sensor Setting" section of the Base instruction sheets.

Note 2: See the Optional Connections / Features page

MODULE MOUNTING LOCATION:

Left Side of Driver's Underdash

Vehicle (Year/Make/Model)	
'07 Focus	
Equipment or Trim level	System(s) applicable to:
ALL	RKE/VSS/RMST
Page	Revision Date
2 of 5	6/1/06

Note: Must Connect To Avoid False Alarms

STEERING COLUMN HARNESS

	Color	Function
A-4	RED	Battery
A-20	GREEN/VIOLET	Door Ajar Input
B-2	RED	HVAC1 Feed
A-7	PINK	Ignition 1 Input/Output
B-4	ORANGE	HVAC 1 Output
A-8	VIOLET	Starter Output
B-8	BLACK/WHITE	Key-in-sense Input
A-21	BROWN/BLACK	Horn Relay Output
B-7	BROWN	Brake Input
A-1	WHITE	Parking Light Output
C-10	RED/WHITE	Headlight Output
C-11	BLUE/WHITE	Rear Defroster Output

MAKE THIS CONNECTION LAST!

Cut and tape off if not used

Optional Installation Feature
See Optional connections page

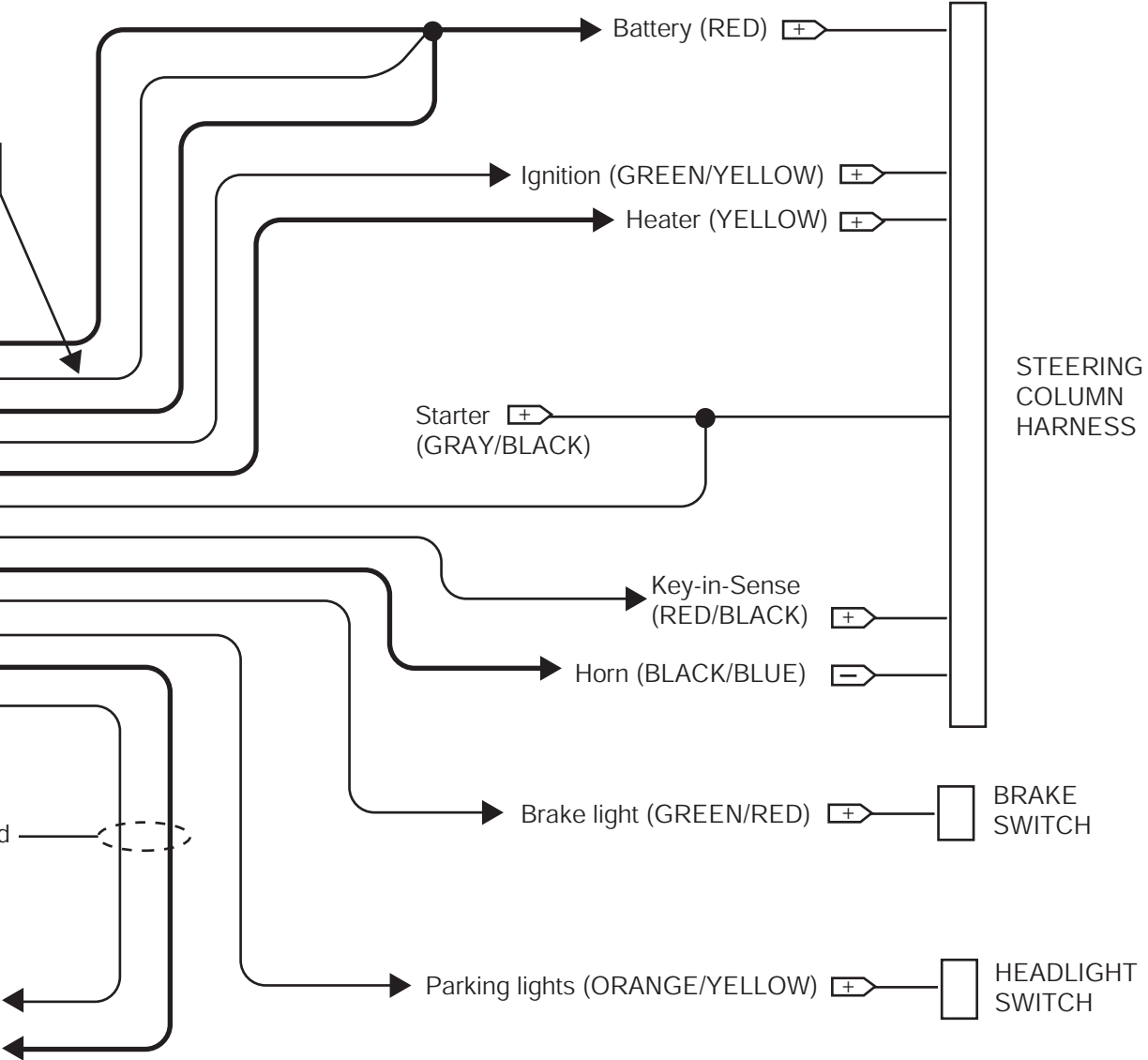

Vehicle (Year/Make/Model)	
'07 Focus	
Equipment or Trim level	System(s) applicable to:
ALL	RKE/VSS/RMST
Page	Revision Date
3 of 5	6/1/06

Note: Must Connect To Avoid False Alarms

DRIVERS SIDE KICK PANEL HARNESS

	Color	Function
A-5	BLACK	Ground
A-10	YELLOW/WHITE	Door Trigger Pull-up Input
A-3	BLACK/WHITE	Dome Light Output
A-2	BLUE	Door Lock Output
A-14	GREEN	Door Unlock Output
C-4	LT GREEN/BLACK	Factory Alarm Disarm Output
A-11	WHITE/BLUE	Arm Input
A-9	BROWN	Disarm Input
A-12	LT.GREEN	Unlock Switch Sense Input
A-13	TAN	Trunk Release Output (-)
A-24	BLUE/GREEN	Driver Door Unlock Output

NOTE: Carefully test all circuits prior to making connections (multiple wires of same color).

MAKE THIS CONNECTION FIRST!

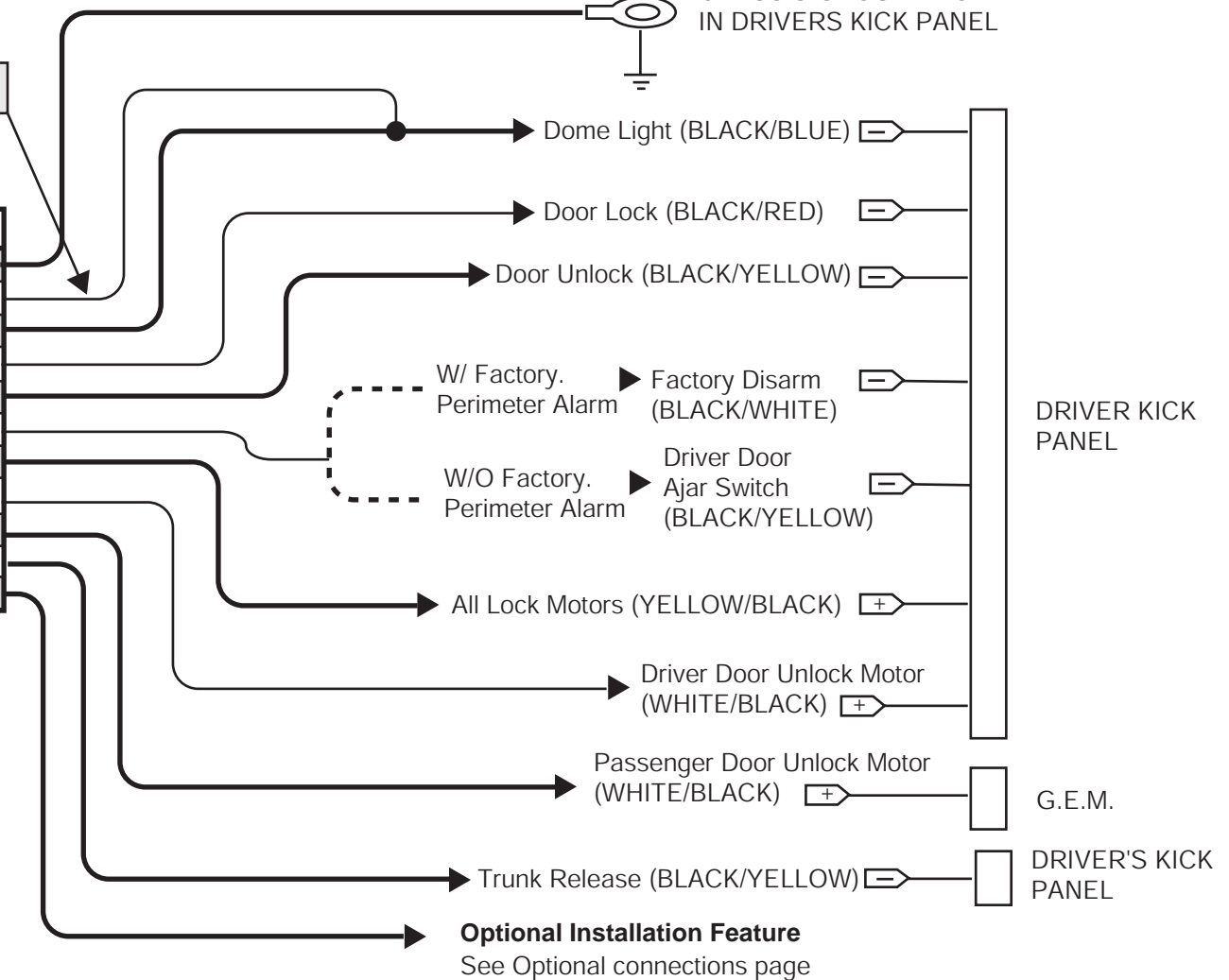
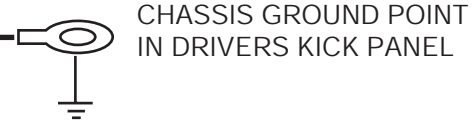

UNDERHOOD HARNESS

	Color	Function
A-19	GRAY	Hood Open Switch Input

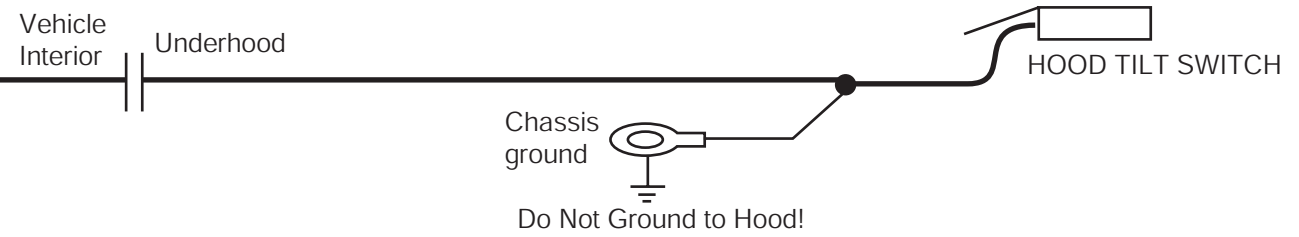

Vehicle (Year/Make/Model) '07 Focus	
Equipment or Trim level ALL	System(s) applicable to: RKE/VSS/RMST
Page 4 of 5	Revision Date 6/1/06

OPTIONAL CONNECTIONS / FEATURES

OPTION PROGRAMMING REQUIREMENTS

BANK	OPTION	DESCRIPTION	LED
3	1	DRIVER PRIORITY UNLOCK	ON

DRIVER'S DOOR PRIORITY UNLOCK

	Color	Function
A-24	BLUE/GREEN	Driver Door Unlock Output

Driver Door Unlock
(BLACK/GREEN)

DRIVER
KICK PANEL

IMPORTANT!

The relay wire colors shown here, are the colors used on the FORD accessory relay kits listed above. Wire colors on other relays may be different!

HEADLIGHT ILLUMINATION / REAR DEFROSTER

	Color	Function
C-10	RED/WHITE	Headlight Output
C-11	BLUE/WHITE	Rear Defroster Output

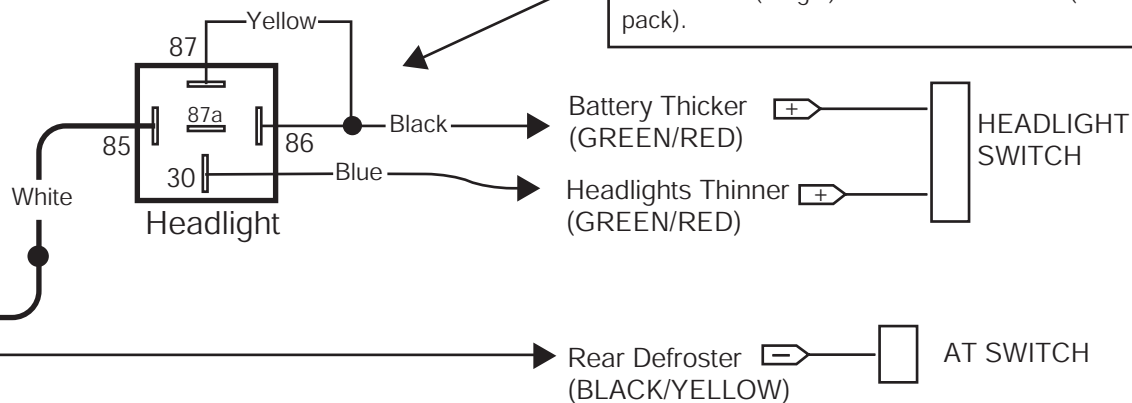

Vehicle (Year/Make/Model) '07 Focus	
Equipment or Trim level ALL	System(s) applicable to: RMST
Page 1 of 3	Revision Date 8/18/06

Module:
PC-14
7L2Z-19G367-AA

FUSE PLACEMENT CHART

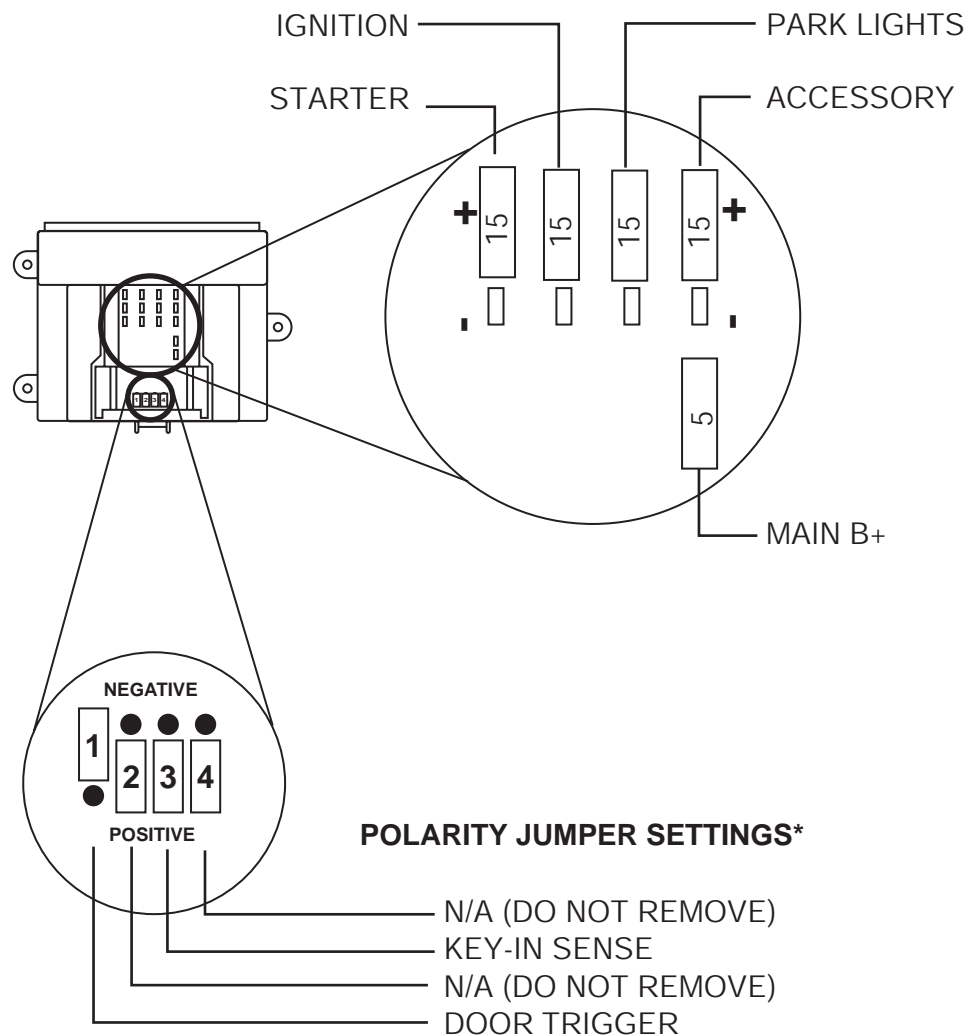

POLARITY JUMPER SETTINGS*

* See Polarity Jumper Section in Base Instructions for details

PARTS REQUIRED:

RMST Kit:
7L2Z-19G364-AA

Securilock (PATS) Interface:
PIK-4 (P/N: 7L2Z-19G365-AA - included)

RELAY REQUIREMENTS (P/N YL3Z-19G390-AA):
3- Power Window & Moonroof Interrupt Circuits

FUNCTIONAL PROGRAMMING REQUIREMENTS

BANK	OPTION	DESCRIPTION	LED
1	2	DOOR AJAR INVERT	ON
1	3	KEY-IN SENSE INVERT	ON
2	1	TACHLESS MODE	ON

MODULE MOUNTING LOCATION:

Left Side of Driver's Underdash

Vehicle (Year/Make/Model) '07 Focus	
Equipment or Trim level ALL	System(s) applicable to: RMST
Page 2 of 3	Revision Date 6/1/06

USE TYPE "A" CUSTOM WIRE HARNESS

VEHICLE HARNESS

IGNITION SWITCH

STEERING COLUMN HARNESS

	Color	Function
A-3	PINK	Ignition Input/Output
A-2	ORANGE	HVAC Output
A-13	VIOLET	Starter Output
B-8	BLACK/WHITE	Key-in-sense Input
A-4	RED	Battery

	Color	Function
A-21	BROWN/BLACK	Horn Relay Output
A-1	WHITE	Parking Light Output



Horn (BLACK/BLUE)

STEERING COLUMN HARNESS

Parking Lights (ORANGE/YELLOW)

HEADLIGHT SWITCH

DRIVER'S KICK PANEL HARNESS

	Color	Function
A-5	BLACK	Ground
A-24	BLUE	Door Lock Output
B-7	BROWN	Brake Input
A-20	GREEN/VIOLET	Door Ajar Switch Input

MAKE THIS CONNECTION FIRST!

CHASSIS GROUND POINT IN DRIVER'S KICK PANEL

Door Lock ((BLACK/RED)

DRIVERS KICK PANEL

Brake (GREEN/RED)

BRAKE SWITCH

Dome Light Return (BLACK/BLUE)

DRIVERS KICK PANEL

UNDER HOOD HARNESS

	Color	Function
A-19	GRAY	Hood Open Switch Input

Vehicle Interior

Engine Compartment

Chassis Ground

Do Not Ground to Hood!

Hood Tilt Switch

Vehicle (Year/Make/Model) '07 Focus	
Equipment or Trim level ALL	System(s) applicable to: RMST
Page 3 of 3	Revision Date 6/1/06

POWER WINDOW AND SUNROOF INTERRUPTS

POWER WINDOW INTERRUPT

	Color	Function
B-10	BLUE/BLACK	Active Output

Relays shown are not supplied in kit. Relays are available by ordering Ford part number YL3Z-19G390-AA (Single) or YL3Z-19G390-BA (10 pack).

CEB = Central Electrib Box

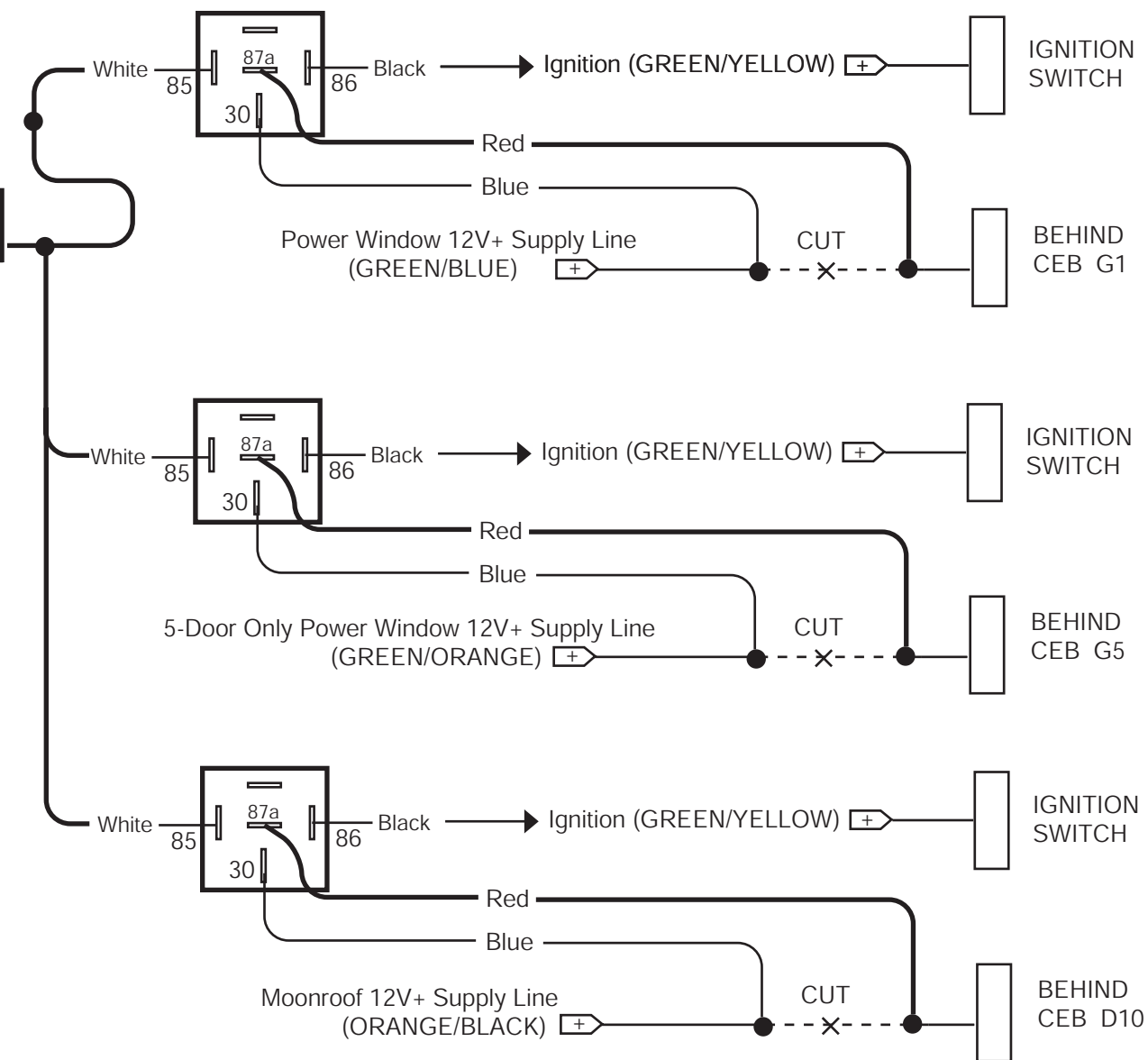

CAUTION: REMOVE YELLOW WIRE AND TERMINAL FROM RELAY SOCKETS

Vehicle (Year/Make/Model) '07 Focus	
Equipment or Trim level ALL	System(s) applicable to: VSS
Page 1 of 2	Revision Date 6/1/06

Module:
PC-14
7L2Z-19G367-AA

FUSE PLACEMENT CHART

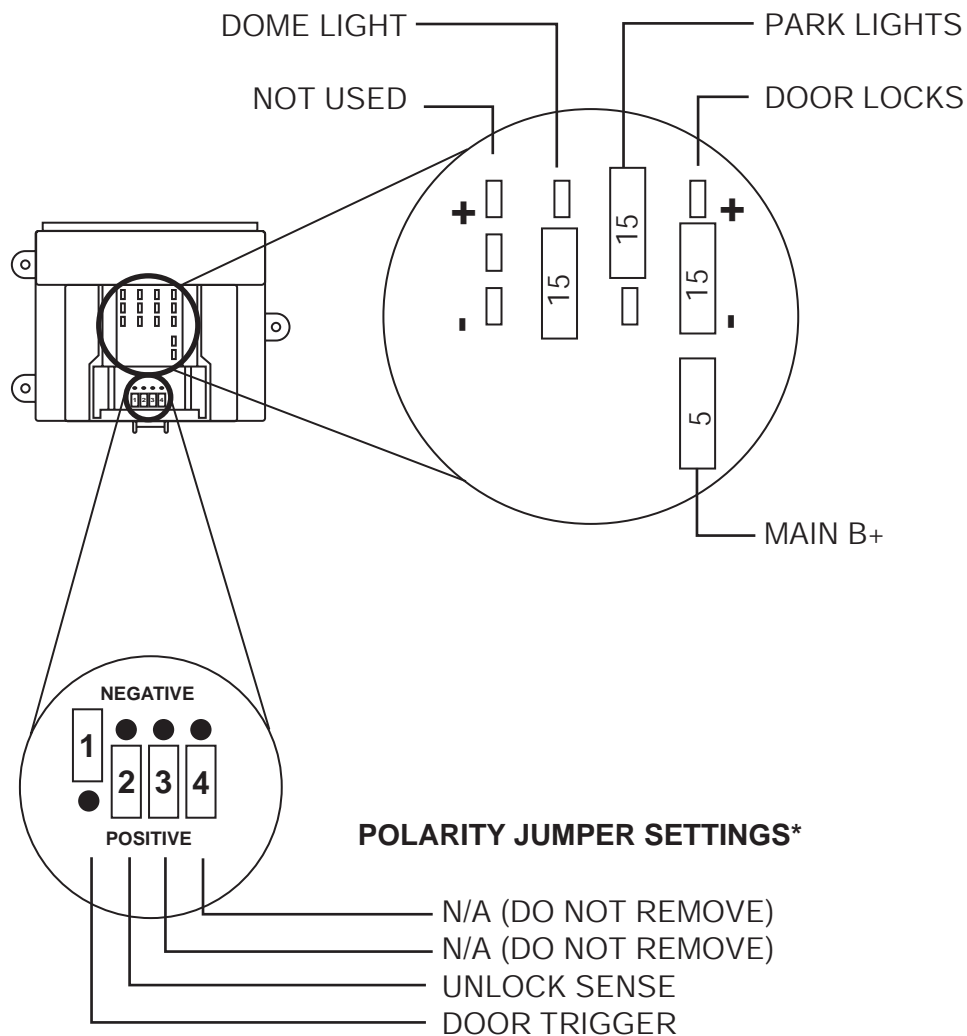

POLARITY JUMPER SETTINGS*

- N/A (DO NOT REMOVE)
- N/A (DO NOT REMOVE)
- UNLOCK SENSE
- DOOR TRIGGER

* See Polarity Jumper Section in Base Instructions for details

PARTS REQUIRED:

VSS Kit:
7L3Z-19A361-AA

FUNCTIONAL PROGRAMMING REQUIREMENTS

BANK	OPTION	DESCRIPTION	LED
1	1	LITE TOUCH ADJUSTMENT	note 1
1	2	FULL SHOCK ADJUSTMENT	note 1
1	4	DOOR AJAR INVERT	ON
1	5	UNLOCK SENSE INVERT	ON
2	1	STARTER INTERRUPT	ON

Note 1: Perform proper adjustments per the "Shock Sensor Setting" section of the Base instruction sheets.

MODULE MOUNTING LOCATION:

Left Side of Driver's Underdash

NOTE:

IF USING THIS SYSTEM IN LOT MODE, WIRE HARNESS P/N 2W7Z-19C757-BA WILL HAVE TO BE ORDERED TO ACCESS THE 'FACTORY DISARM OUTPUT" WIRE (LT.GREEN/BLACK).

Vehicle (Year/Make/Model)	
'07 Focus	
Equipment or Trim level	System(s) applicable to:
ALL	VSS
Page	Revision Date
2 of 2	6/1/06

DRIVERS SIDE KICK PANEL HARNESS

	Color	Function
A-5	BLACK	Ground
A-10	YELLOW/WHITE	Door Trigger Pull-up
A-3	BLACK/WHITE	Dome Light Output
A-2	BLUE	Door Lock Output
A-14	GREEN	Door Unlock Output
C-4	LT GREEN/BLACK	Factory Alarm Disarm Output
A-11	WHITE/BLUE	Arm Input
A-9	BROWN	Disarm Input
A-12	LT.GREEN	Unlock Switch Sense Input

Connect only if system will be used in Lot Mode

Note: Must Connect To Avoid False Alarms

STEERING COLUMN HARNESS

	Color	Function
A-4	RED	Battery
A-20	GREEN/VIOLET	Door Ajar Input
A-7	PINK	Ignition 1 Input/Output
A-8	VIOLET	Starter Interrupt (Motor side)
A-6	VIOLET/RED	Starter Interrupt (Key side)
A-21	BROWN/BLACK	Horn Relay Output
A-13	TAN	Trunk Release Output (-)
A-1	WHITE	Parking Light Output

NOTE: Carefully test all circuits prior to making connections (multiple wires of same color).

MAKE THIS CONNECTION FIRST!

CHASSIS GROUND POINT IN DRIVERS KICK PANEL

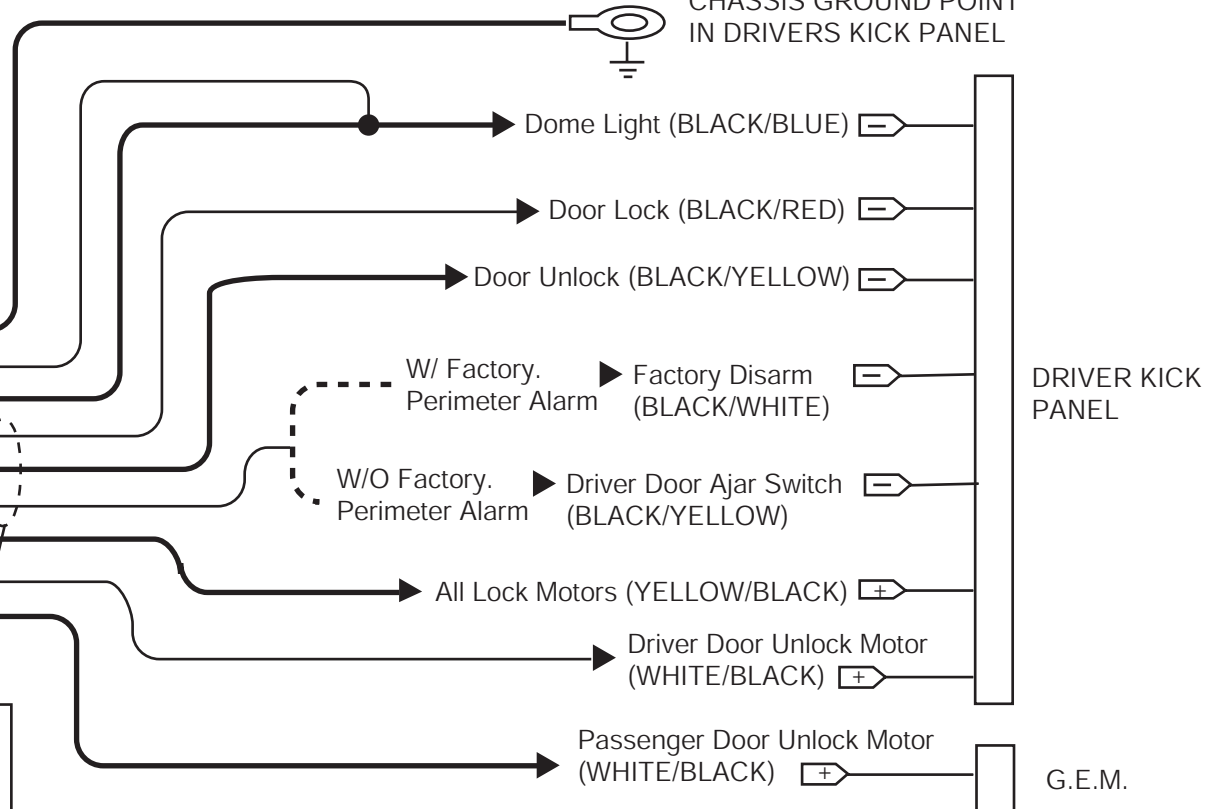

MAKE THIS CONNECTION LAST!

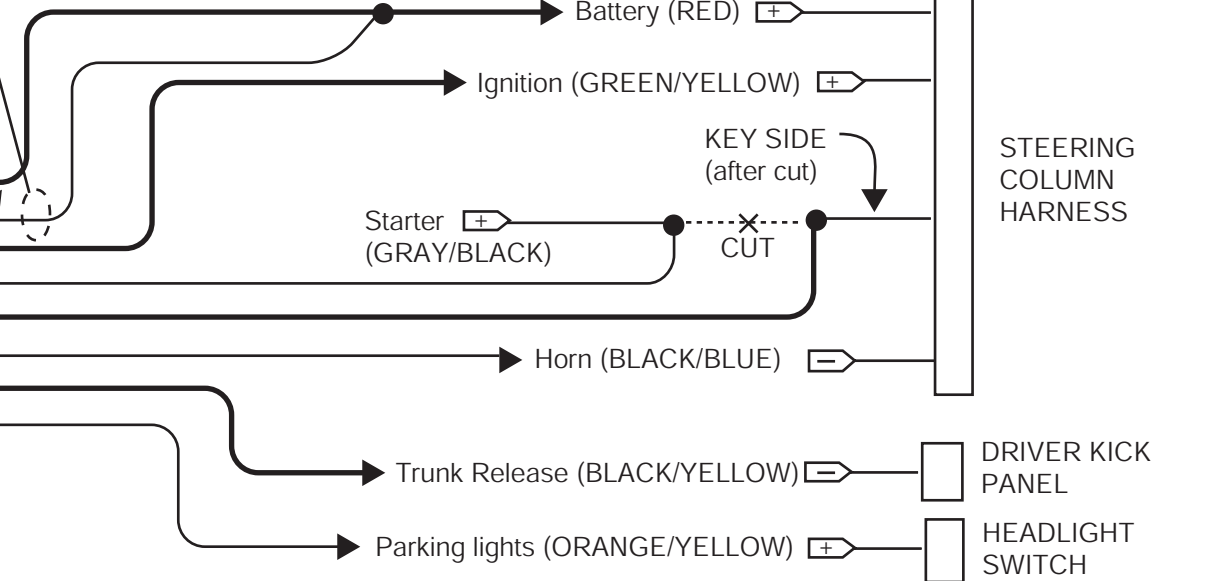

Vehicle (Year/Make/Model) '07 Fusion / Milan	
Equipment or Trim level ALL	System(s) applicable to: RKE/VSS/RMST
Page 1 of 5	Revision Date 8/18/06

Module:
PC-34
7L3Z-19G367-AA

FUSE PLACEMENT CHART

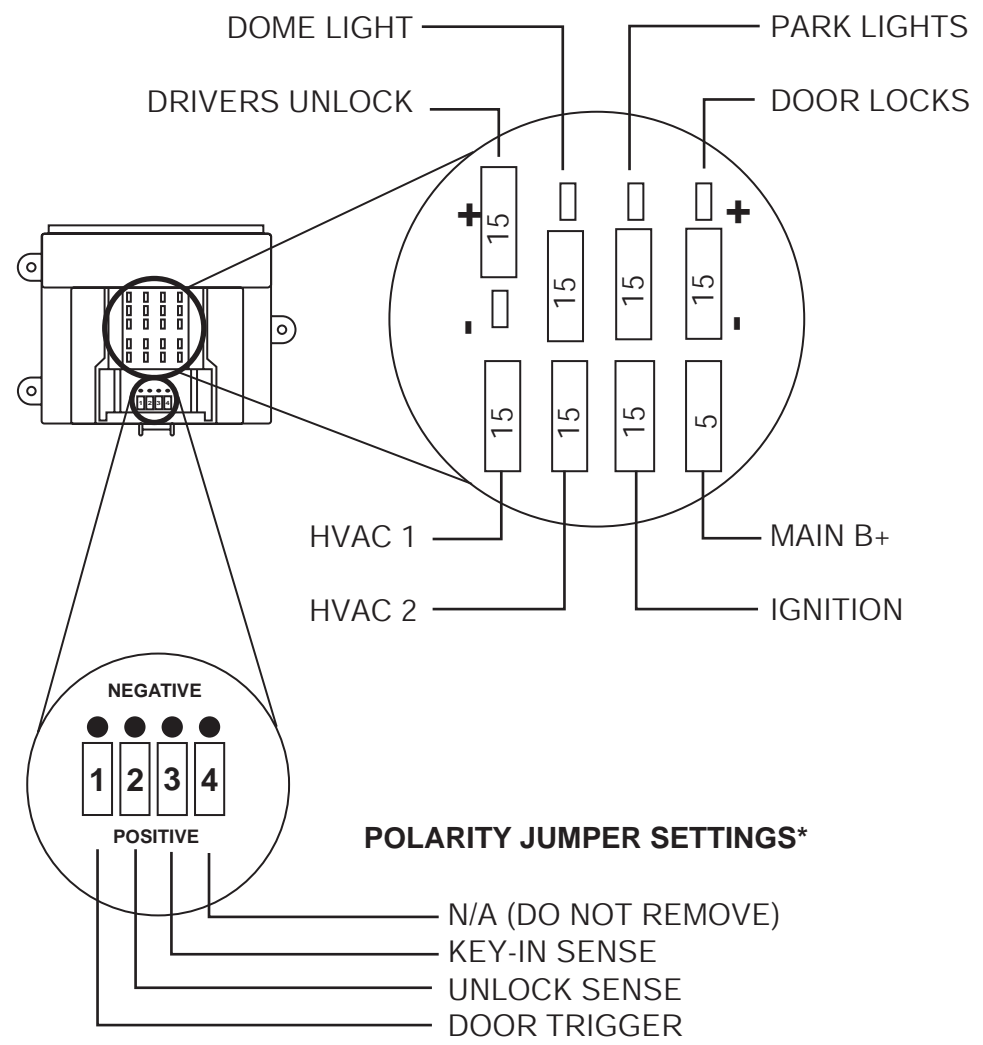

POLARITY JUMPER SETTINGS*

* See Polarity Jumper Section in Base Instructions for details

PARTS REQUIRED:

RKE/VSS/RMST Kit:
7L3Z-19G364-AA

Securilock (PATS) Interface:
PIK-4 (P/N: 7L2Z-19G365-AA - order separately)

RELAY REQUIREMENTS (P/N YL3Z-19G390-AA):
1- Parking Light Operation (all platforms)
1- Parking Light Operation with Autolamps (additional relay)

FUNCTIONAL PROGRAMMING REQUIREMENTS

BANK	OPTION	DESCRIPTION	LED
1	1	LITE TOUCH ADJUSTMENT	note 1
1	2	FULL SHOCK ADJUSTMENT	note 1
1	4	DOOR AJAR INVERT	ON
1	5	UNLOCK SENSE INVERT	ON
1	6	KEY-IN SENSE INVERT	ON
2	1	STARTER INTERRUPT	OFF
2	8	DRIVER UNLOCK RELAY	note 2
3	1	DRIVER PRIORITY UNLOCK	note 2
4	1	TACHLESS MODE	ON

Note 1: Perform proper adjustments per the "Shock Sensor Setting" section of the Base instruction sheets.
Note 2: See the Optional Connections / Features page

MODULE MOUNTING LOCATION:
Left Side of Driver's Underdash

Vehicle (Year/Make/Model) '07 Fusion / Milan	
Equipment or Trim level ALL	System(s) applicable to: RKE/VSS/RMST
Page 2 of 5	Revision Date 6/28/06

STEERING COLUMN HARNESS

	Color	Function
A-4	RED	Battery
B-2	RED	HVAC1 Battery Feed
A-7	PINK	Ignition 1 Input/Output
B-4	ORANGE	HVAC1 Output
B-8	BLACK/WHITE	Key-in-sense Input
A-8	VIOLET	Starter Interrupt Motor Side
A-21	BROWN/BLACK	Horn Relay Output
B-7	BROWN	Brake Input

MAKE THIS CONNECTION LAST!

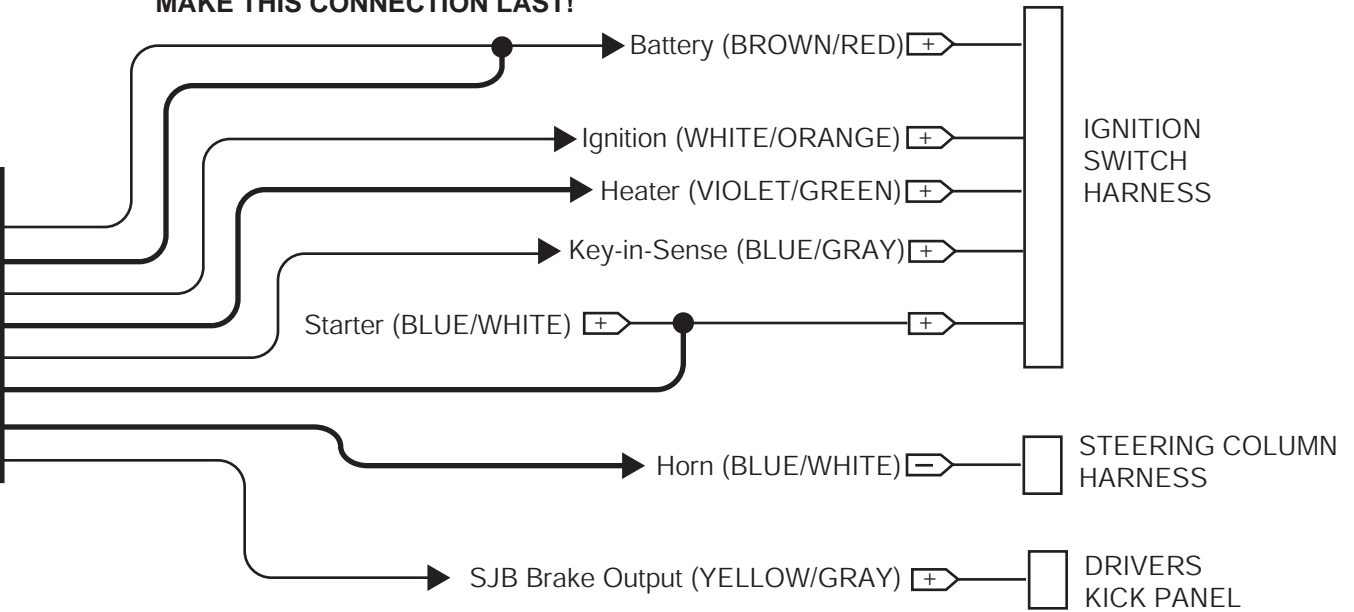

UNDERHOOD HARNESS

	Color	Function
A-19	GRAY	Hood Open Switch Input

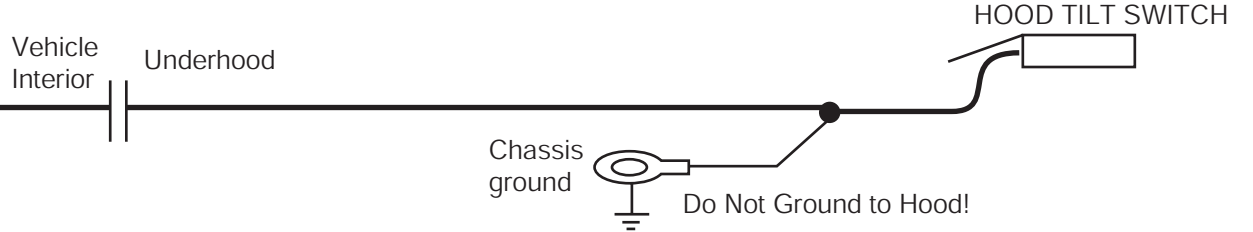

Vehicle (Year/Make/Model) '07 Fusion / Milan	
Equipment or Trim level ALL	System(s) applicable to: RKE/VSS/RMST
Page 3 of 5	Revision Date 6/28/06

MAKE THIS CONNECTION FIRST!

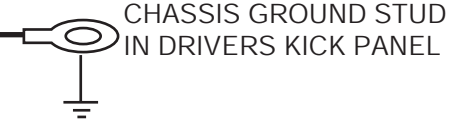

DRIVER'S SIDE KICK PANEL HARNESS

	Color	Function
A-5	BLACK	Ground

See "SJB Layout" page for connector locations.

KICK PANEL HARNESS

	Color	Function
A-20	GREEN/VIOLET	Door Ajar Switch Input
A-11	WHITE/BLUE	Arm Input
A-2	BLUE	Door Lock Output
A-14	GREEN	Door Unlock Output
A-12	LT. GREEN	Unlock Switch Sense Input
A-9	BROWN	Disarm Input
C-4	LT GREEN/BLACK	Factory Alarm Disarm
A-24	BLUE/GREEN	Driver Door Unlock Output
A-3	BLACK/WHITE	Dome Light Output

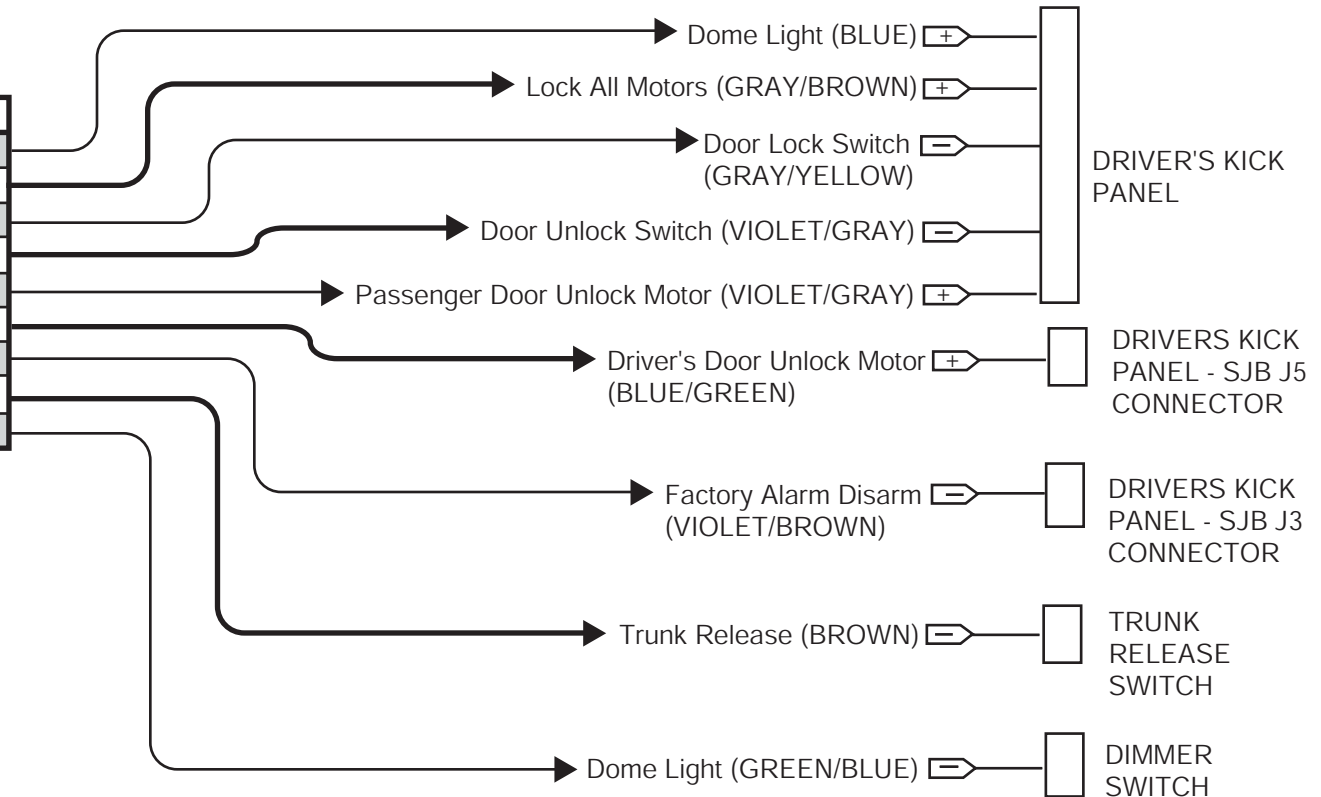

Vehicle (Year/Make/Model) '07 Fusion / Milan	
Equipment or Trim level ALL	System(s) applicable to: RKE/VSS/RMST
Page 4 of 5	Revision Date 6/28/06

HEADLAMP SWITCH HARNESS

	Color	Function
A-1	WHITE	Parking Light Output

Relays shown are not supplied in kit.
Relays are available by ordering Ford part number YL3Z-19G390-AA (Single) or YL3Z-19G390-BA (10 pack).

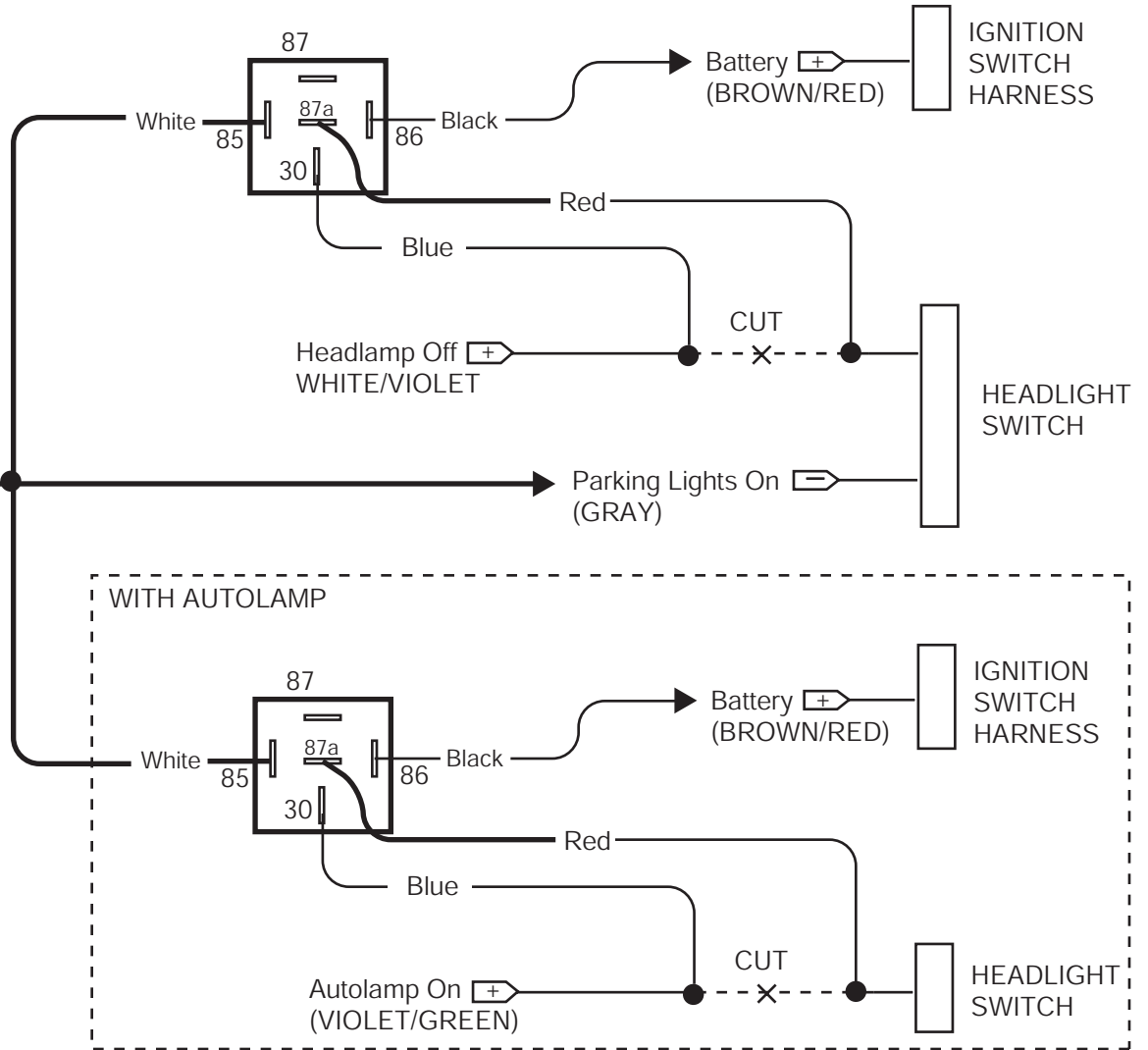

Vehicle (Year/Make/Model) '07 Fusion / Milan	
Equipment or Trim level ALL	System(s) applicable to: RKE/VSS/RMST
Page 5 of 5	Revision Date 6/28/06

OPTIONAL CONNECTIONS / FEATURES

OPTION PROGRAMMING REQUIREMENTS

BANK	OPTION	DESCRIPTION	LED
2	8	DRIVER UNLOCK RELAY	ON
3	1	DRIVER PRIORITY UNLOCK	ON

DRIVER'S DOOR PRIORITY UNLOCK

	Color	Function
C-9	TAN/RED	Driver Door Unlock Switch
A-13	TAN	Driver Door Unlock Motor
A-9	BROWN	Disarm Input

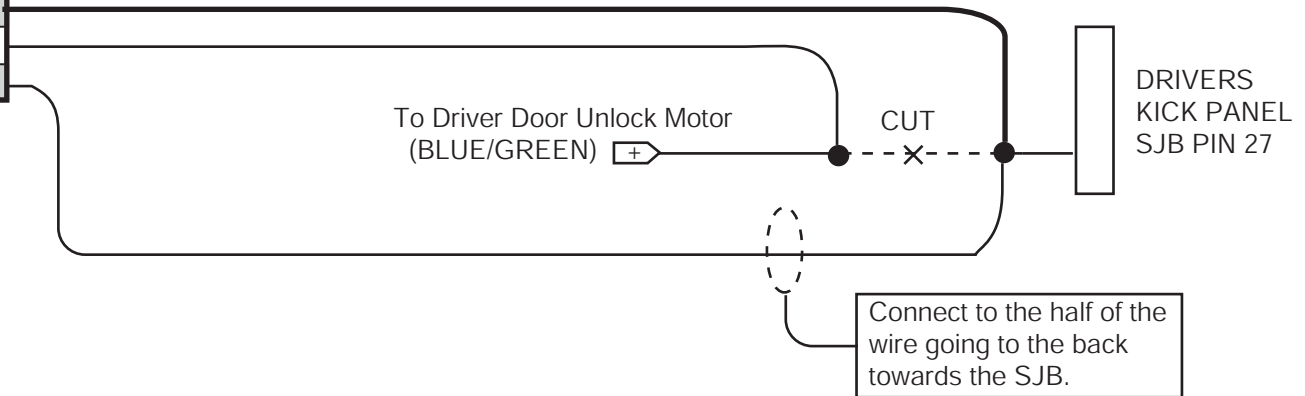

HEADLIGHTS/REAR DEFROSTER

	Color	Function
C-10	RED/WHITE	Headlight Output
C-11	BLUE/WHITE	Rear Defroster Output



Vehicle (Year/Make/Model) '07 Fusion / Milan	
Equipment or Trim level ALL	System(s) applicable to: RMST
Page 1 of 3	Revision Date 8/18/06

Module:
PC-14
7L2Z-19G367-AA

FUSE PLACEMENT CHART

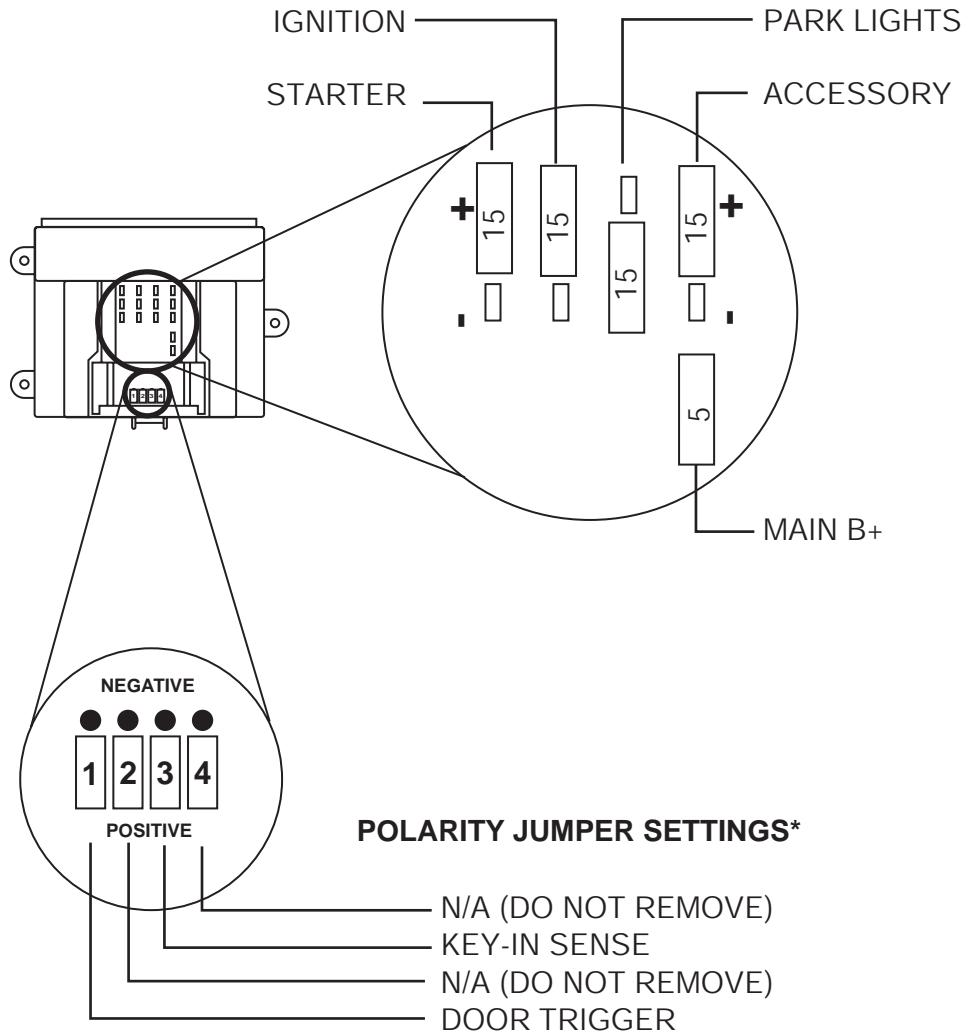

* See Polarity Jumper Section in Base Instructions for details

PARTS REQUIRED:

RMST Kit:
7L2Z-19G364-AA

Securilock (PATS) Interface:
PIK-4 (P/N: 7L2Z-19G365-AA - included)

FUNCTIONAL PROGRAMMING REQUIREMENTS

BANK	OPTION	DESCRIPTION	LED
1	2	DOOR AJAR INVERT	ON
1	3	KEY-IN SENSE INVERT	ON
2	1	TACHLESS MODE	ON

MODULE MOUNTING LOCATION:

Left Side of Driver's Underdash

Vehicle (Year/Make/Model) '07 Fusion / Milan	
Equipment or Trim level ALL	System(s) applicable to: RMST
Page 2 of 3	Revision Date 6/28/06

USE TYPE "A" CUSTOM WIRE HARNESS

VEHICLE HARNESS

IGNITION SWITCH

STEERING COLUMN HARNESS

	Color	Function
A-3	PINK	Ignition Input/Output
A-2	ORANGE	HVAC Output
A-13	VIOLET	Starter Output
B-8	BLACK/WHITE	Key-in-sense Input
A-4	RED	Battery

	Color	Function
A-21	BROWN/BLACK	Horn Relay Output

Horn (BLUE/WHITE)

STEERING COLUMN HARNESS

DRIVER'S KICK PANEL HARNESS

	Color	Function
A-5	BLACK	Ground
A-24	BLUE	Door Lock Output
B-7	BROWN	Brake Input
A-20	GREEN/VIOLET	Door Ajar Switch Input

MAKE THIS CONNECTION FIRST!

CHASSIS GROUND POINT IN DRIVER'S KICK PANEL



Door Lock (GRAY/YELLOW)

Brake (YELLOW/GRAY)

Dome Light (BLUE)

DRIVERS KICK PANEL

UNDER HOOD HARNESS

	Color	Function
A-19	GRAY	Hood Open Switch Input

Vehicle Interior

Engine Compartment

Hood Tilt Switch

Chassis Ground

Do Not Ground to Hood!

Vehicle (Year/Make/Model) '07 Fusion / Milan	
Equipment or Trim level w/ factory RKE	System(s) applicable to: VSS or RMST
Page 3 of 3	Revision Date 6/28/06

HEADLAMP SWITCH HARNESS

	Color	Function
A-1	WHITE	Parking Light Output

Relays shown are not supplied in kit.
Relays are available by ordering Ford part number YL3Z-19G390-AA (Single) or YL3Z-19G390-BA (10 pack).

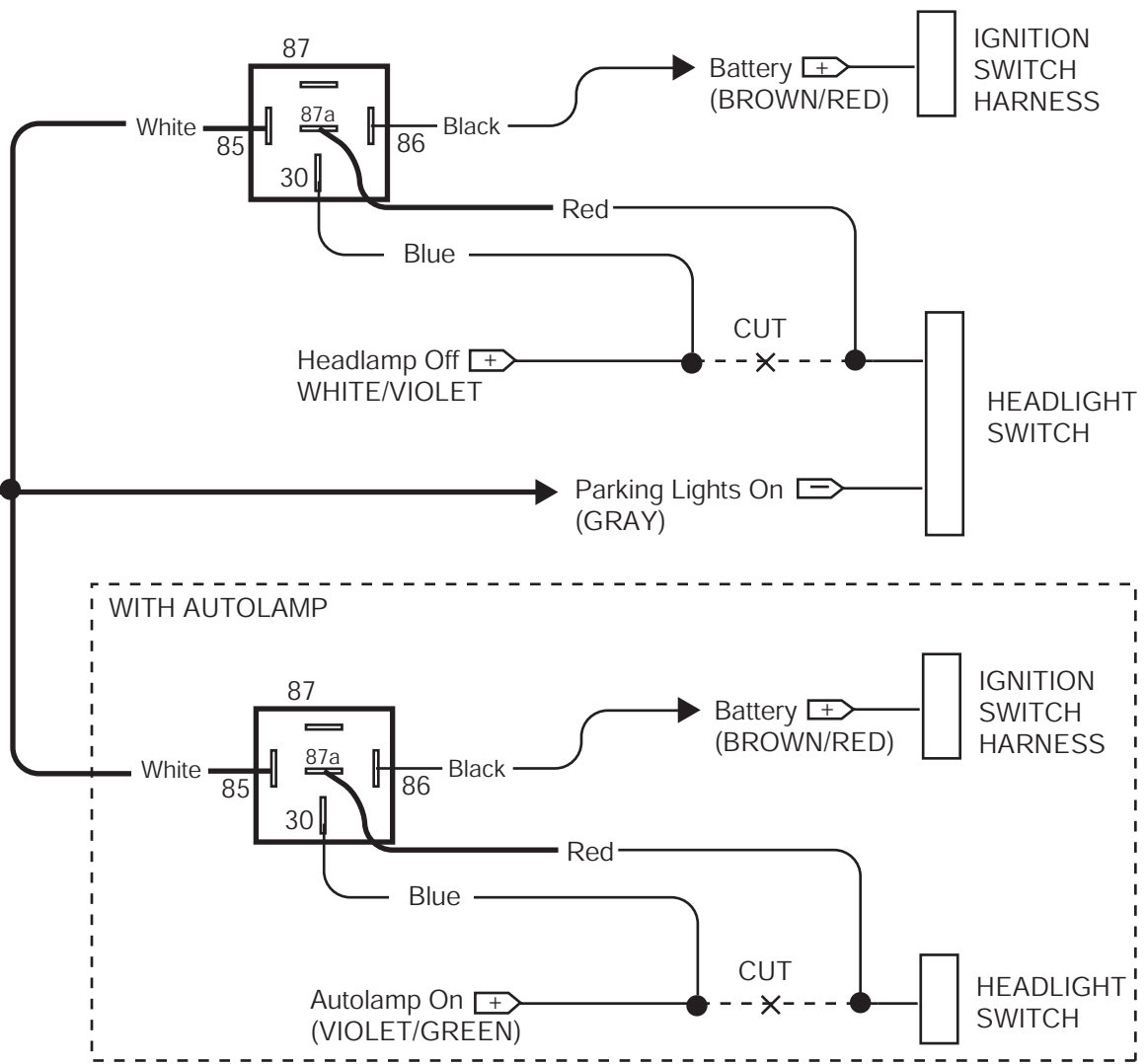

Vehicle (Year/Make/Model) '07 Fusion / Milan	
Equipment or Trim level ALL	System(s) applicable to: VSS
Page 1 of 3	Revision Date 6/28/06

Module:
PC-14
7L2Z-19G367-AA

FUSE PLACEMENT CHART

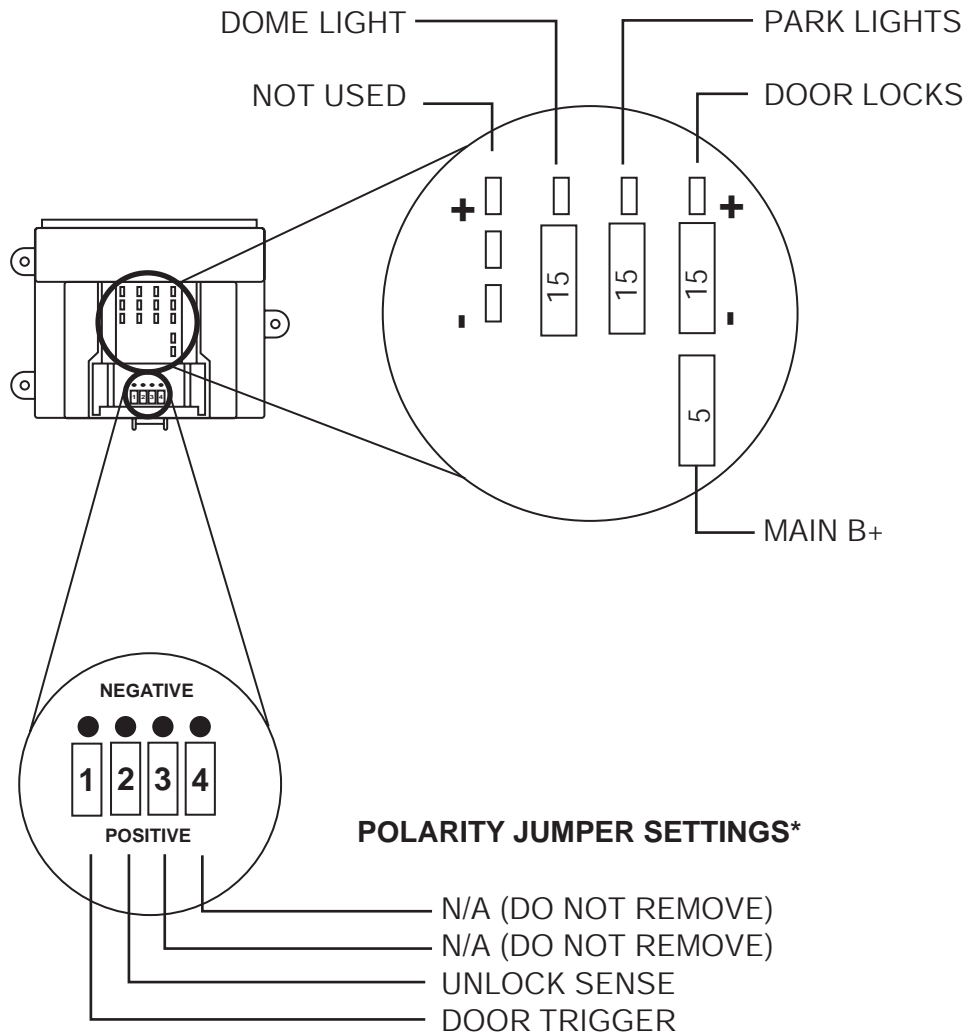

* See Polarity Jumper Section in Base Instructions for details

PARTS REQUIRED:

VSS Kit:
7L3Z-19A361-AA

FUNCTIONAL PROGRAMMING REQUIREMENTS

BANK	OPTION	DESCRIPTION	LED
1	1	LITE TOUCH ADJUSTMENT	note 1
1	2	FULL SHOCK ADJUSTMENT	note 1
1	4	DOOR AJAR INVERT	ON
1	5	UNLOCK SENSE INVERT	ON
2	1	STARTER INTERRUPT	ON

Note 1: Perform proper adjustments per the "Shock Sensor Setting" section of the Base instruction sheets.

MODULE MOUNTING LOCATION:

Left Side of Driver's Underdash

NOTE:

IF USING THIS SYSTEM IN LOT MODE, WIRE HARNESS P/N 2W7Z-19C757-BA WILL HAVE TO BE ORDERED TO ACCESS THE 'FACTORY DISARM OUTPUT" WIRE (LT.GREEN/BLACK).

Vehicle (Year/Make/Model) '07 Fusion / Milan	
Equipment or Trim level w/ factory RKE	System(s) applicable to: VSS
Page 2 of 3	Revision Date 6/28/06

STEERING COLUMN HARNESS

	Color	Function
A-4	RED	Battery
A-7	PINK	Ignition 1 Input/Output
A-8	VIOLET	Starter Interrupt Motor Side
A-6	VIOLET/RED	Starter Interrupt Key Side
A-21	BROWN/BLACK	Horn Relay Output

MAKE THIS CONNECTION LAST!

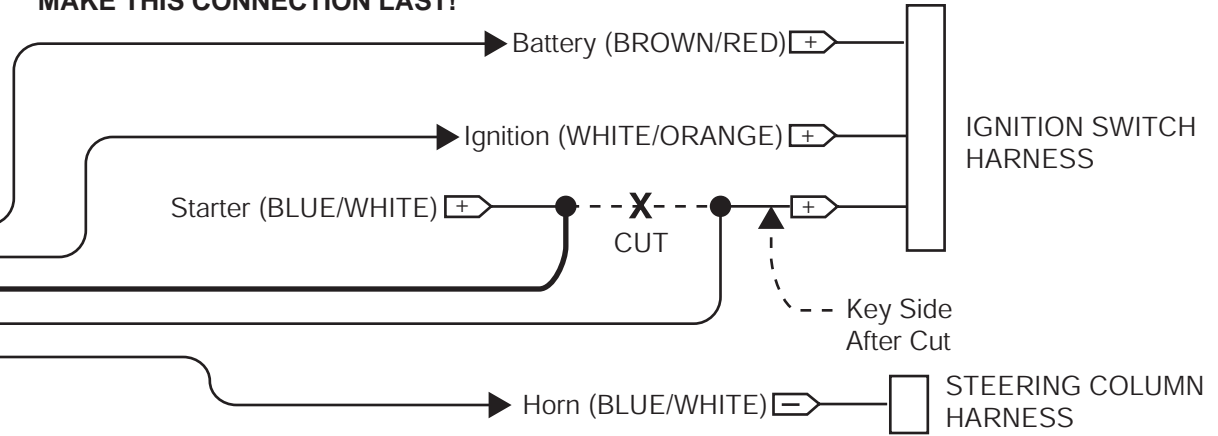

DRIVER'S SIDE KICK PANEL HARNESS

	Color	Function
A-5	BLACK	Ground

MAKE THIS CONNECTION FIRST!



KICK PANEL HARNESS

	Color	Function
A-20	GREEN/VIOLET	Door Ajar Switch Input
A-11	WHITE/BLUE	Arm Input
A-2	BLUE	Door Lock Output
A-14	GREEN	Door Unlock Output
A-12	LT. GREEN	Unlock Switch Sense Input
A-9	BROWN	Disarm Input
C-4	LT GREEN/BLACK	Factory Alarm Disarm

Connect only if system will be used in Lot Mode

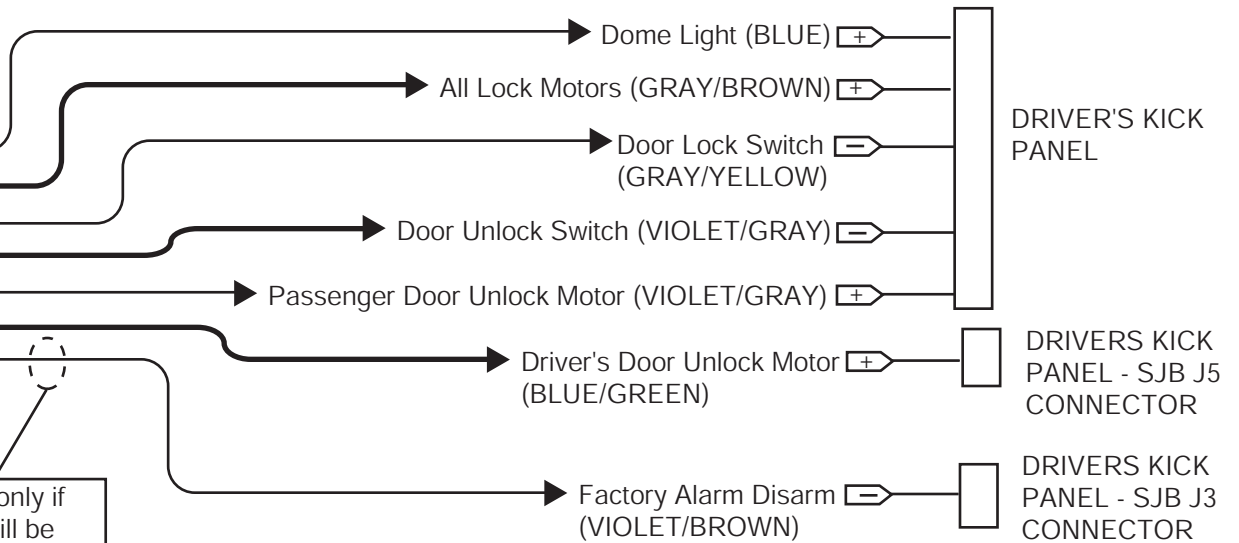

See "SJB Layout" page for connector locations.

Vehicle (Year/Make/Model) '07 Fusion / Milan	
Equipment or Trim level ALL	System(s) applicable to: ALL
Page 1 of 1	Revision Date 6/28/06

(SJB)

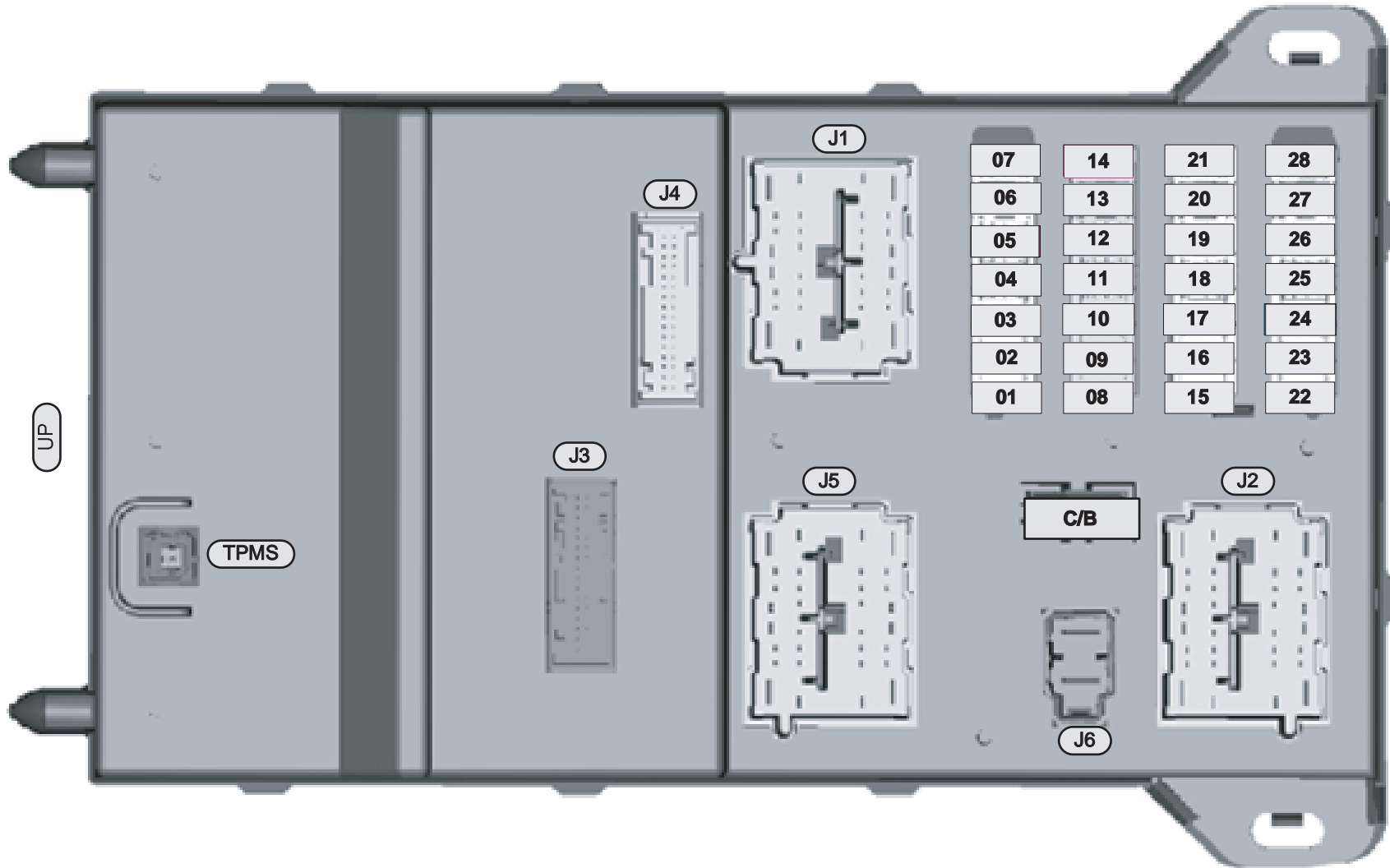

Vehicle (Year/Make/Model) '07 MKZ	
Equipment or Trim level ALL	System(s) applicable to: RMST
Page 1 of 4	Revision Date 8/18/06

Module:
PC-14
7L2Z-19G367-AA

FUSE PLACEMENT CHART

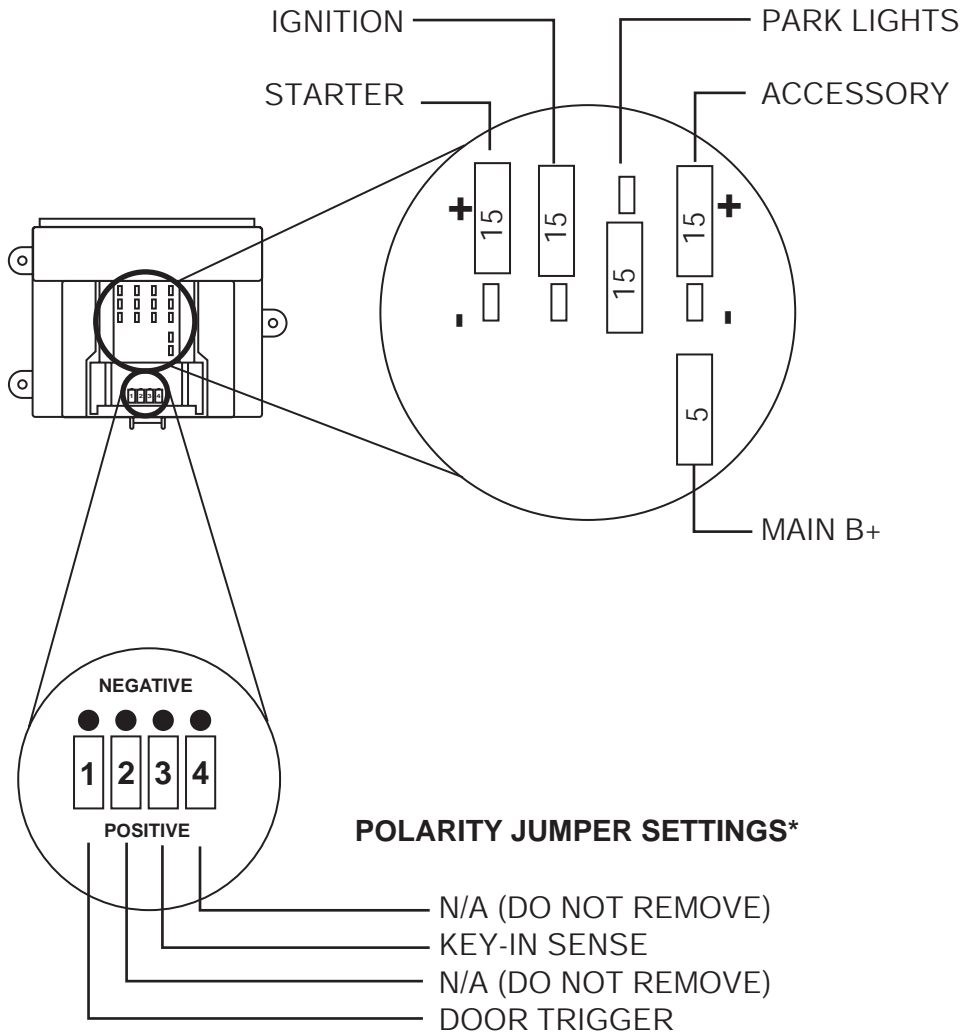

POLARITY JUMPER SETTINGS*

* See Polarity Jumper Section in Base Instructions for details

PARTS REQUIRED:

RMST Kit:
7L2Z-19G364-AA

Securilock (PATS) Interface:
PIK-4 (P/N: 7L2Z-19G365-AA - included)

FUNCTIONAL PROGRAMMING REQUIREMENTS

BANK	OPTION	DESCRIPTION	LED
1	2	DOOR AJAR INVERT	ON
1	3	KEY-IN SENSE INVERT	ON
2	1	TACHLESS MODE	ON

MODULE MOUNTING LOCATION:

Left Side of Driver's Underdash

Vehicle (Year/Make/Model) '07 MKZ	
Equipment or Trim level ALL	System(s) applicable to: RMST
Page 2 of 4	Revision Date 8/18/06

USE TYPE "A" CUSTOM WIRE HARNESS

VEHICLE HARNESS

IGNITION SWITCH

STEERING COLUMN HARNESS

	Color	Function
A-3	PINK	Ignition Input/Output
A-2	ORANGE	HVAC Output
A-13	VIOLET	Starter Output
B-8	BLACK/WHITE	Key-in-sense Input
A-4	RED	Battery

	Color	Function
A-21	BROWN/BLACK	Horn Relay Output

Horn (BLUE/WHITE)

STEERING COLUMN HARNESS

DRIVER'S KICK PANEL HARNESS

	Color	Function
A-5	BLACK	Ground
B-7	BROWN	Brake Input
A-20	GREEN/VIOLET	Door Ajar Switch Input

MAKE THIS CONNECTION FIRST!

CHASSIS GROUND POINT IN DRIVER'S KICK PANEL

Brake (YELLOW/GRAY)

Dome Light (BLUE)

DRIVERS KICK PANEL

UNDER HOOD HARNESS

	Color	Function
A-19	GRAY	Hood Open Switch Input

Vehicle Interior

Engine Compartment

Chassis Ground

Do Not Ground to Hood!

Hood Tilt Switch

Vehicle (Year/Make/Model) '07 MKZ	
Equipment or Trim level ALL	System(s) applicable to: RMST
Page 3 of 4	Revision Date 8/18/06

HEADLAMP SWITCH HARNESS

	Color	Function
A-1	WHITE	Parking Light Output

Relays shown are not supplied in kit.
Relays are available by ordering Ford part number YL3Z-19G390-AA (Single) or YL3Z-19G390-BA (10 pack).

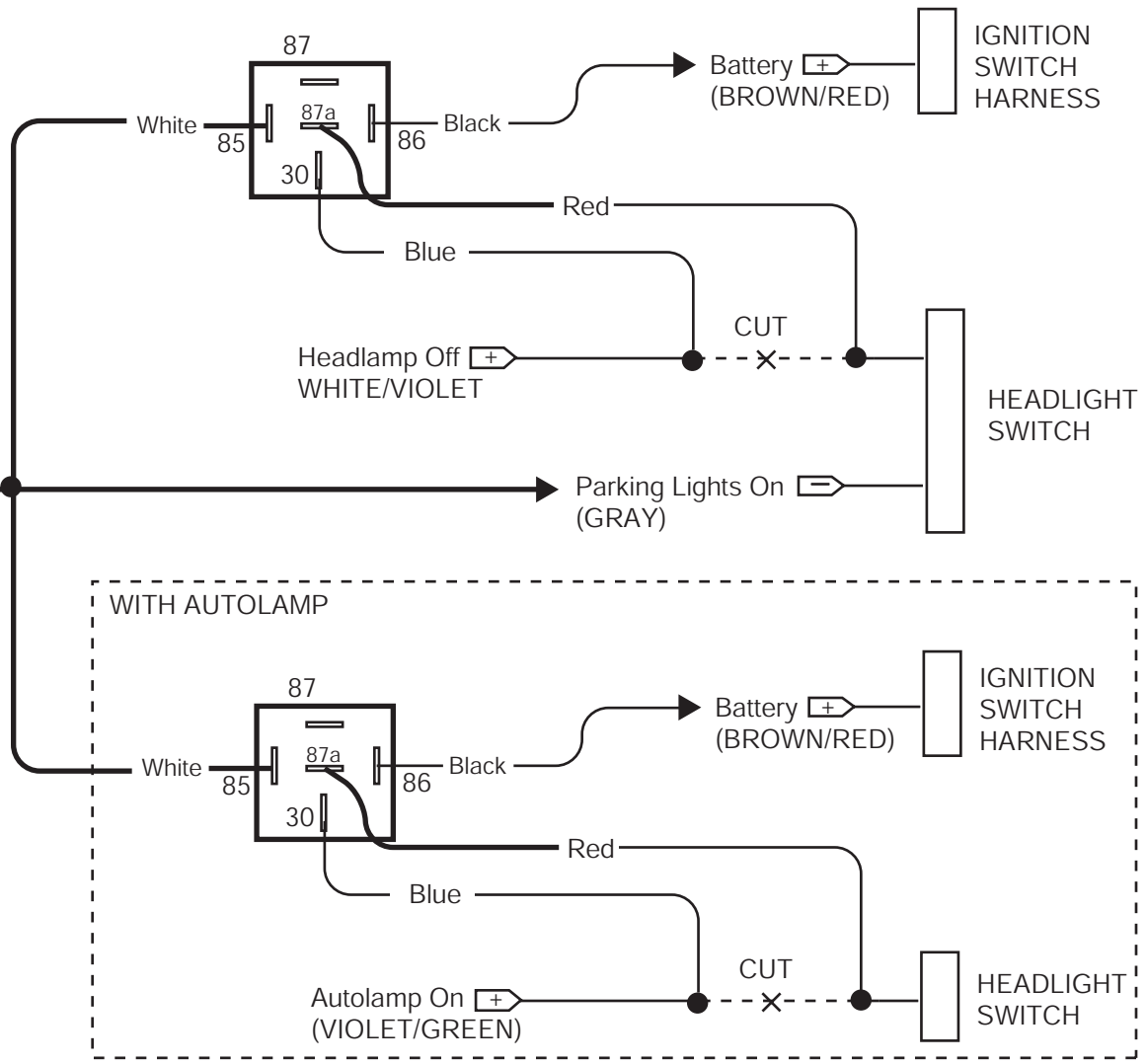

Vehicle (Year/Make/Model) '07 MKZ	
Equipment or Trim level ALL	System(s) applicable to: RMST
Page 4 of 4	Revision Date 8/18/06

(SJB)

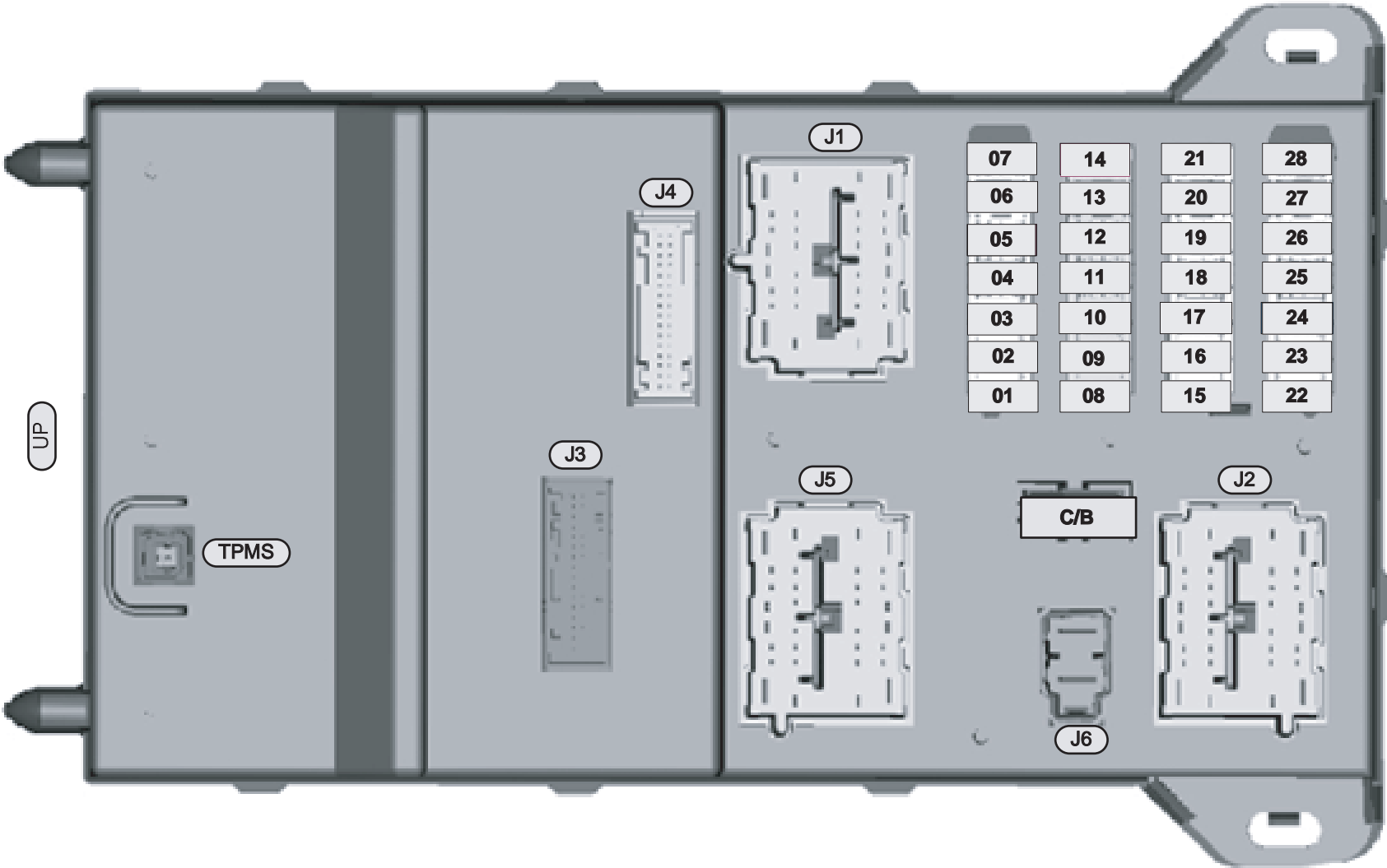

Vehicle (Year/Make/Model) '07 Mustang	
Equipment or Trim level ALL	System(s) applicable to: RKE/VSS/RMST
Page 1 of 4	Revision Date 8/18/06

Module:
PC-34
7L3Z-19G367-AA

FUSE PLACEMENT CHART

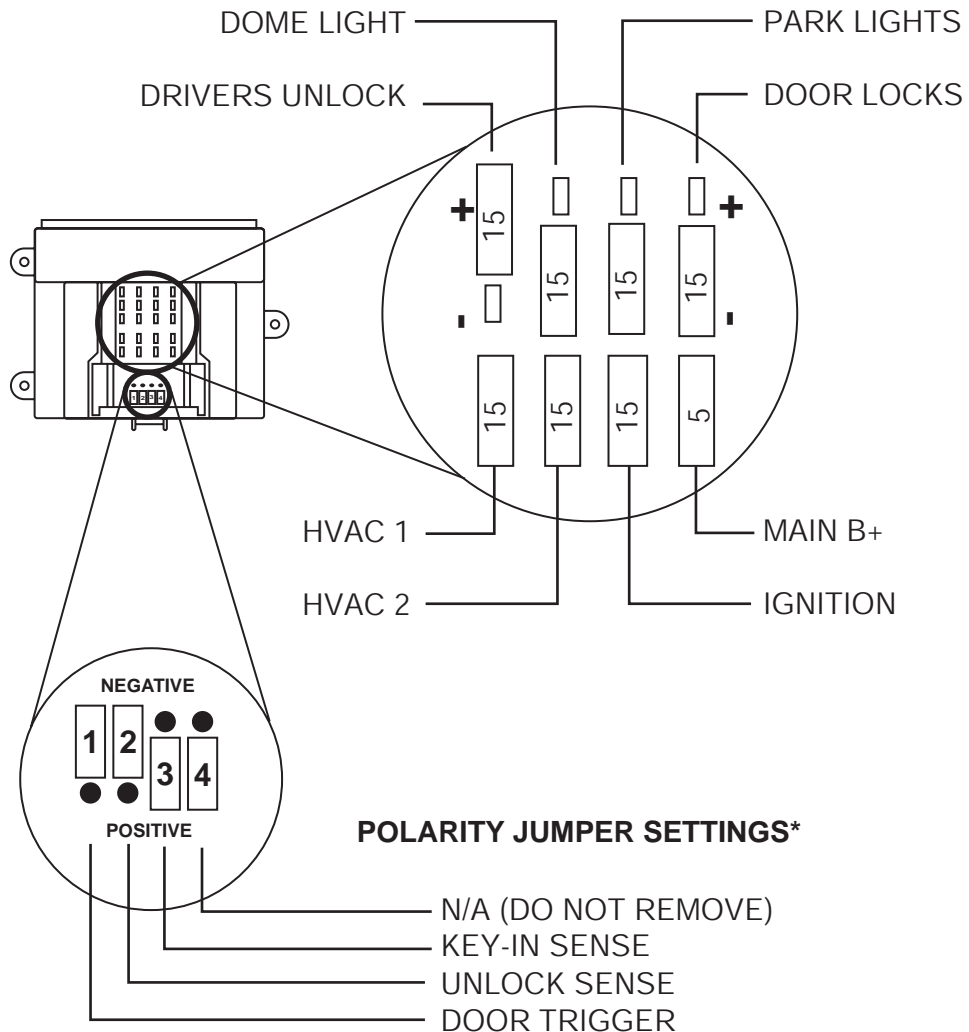

POLARITY JUMPER SETTINGS*

* See Polarity Jumper Section in Base Instructions for details

PARTS REQUIRED:

RKE/VSS/RMST Kit:
7L3Z-19G364-AA

Securilock (PATS) Interface:
PIK-4 (P/N: 7L2Z-19G365-AA - order separately)

FUNCTIONAL PROGRAMMING REQUIREMENTS

BANK	OPTION	DESCRIPTION	LED
1	1	LITE TOUCH ADJUSTMENT	note 1
1	2	FULL SHOCK ADJUSTMENT	note 1
1	4	DOOR AJAR INVERT	ON
1	5	UNLOCK SENSE INVERT	ON
1	6	KEY-IN SENSE INVERT	ON
2	1	STARTER INTERRUPT	OFF
2	8	DRIVER UNLOCK RELAY	note 2
3	1	DRIVER PRIORITY UNLOCK	note 2
4	1	TACHLESS MODE	ON

Note 1: Perform proper adjustments per the "Shock Sensor Setting" section of the Base instruction sheets.

Note 2: See the Optional Connections / Features page

MODULE MOUNTING LOCATION:

Left Side of Driver's Underdash

Vehicle (Year/Make/Model) '07 Mustang	
Equipment or Trim level ALL	System(s) applicable to: RKE/VSS/RMST
Page 2 of 4	Revision Date 8/18/06

DRIVER'S SIDE KICK PANEL HARNESS

	Color	Function
A-5	BLACK	Ground

MAKE THIS CONNECTION FIRST!

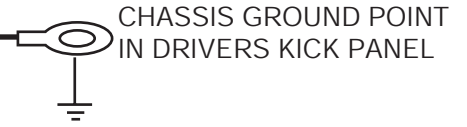

MAKE THIS CONNECTION LAST!

Note: Must Connect To Avoid False Alarms

STEERING COLUMN HARNESS

	Color	Function
A-4	RED	Battery
A-20	GREEN/VIOLET	Door Trigger Input Pull-up
B-2	RED	HVAC1 Battery Feed
A-7	PINK	Ignition 1 Input/Output
B-4	ORANGE	HVAC1 Output
B-8	BLACK/WHITE	Key-in-sense Input
A-8	VIOLET	Starter Interrupt Motor Side
A-21	BROWN/BLACK	Horn Relay Output
A-3	BLACK/WHITE	Dome Light Output
A-1	WHITE	Parking Light Output
B-7	BROWN	Brake Input

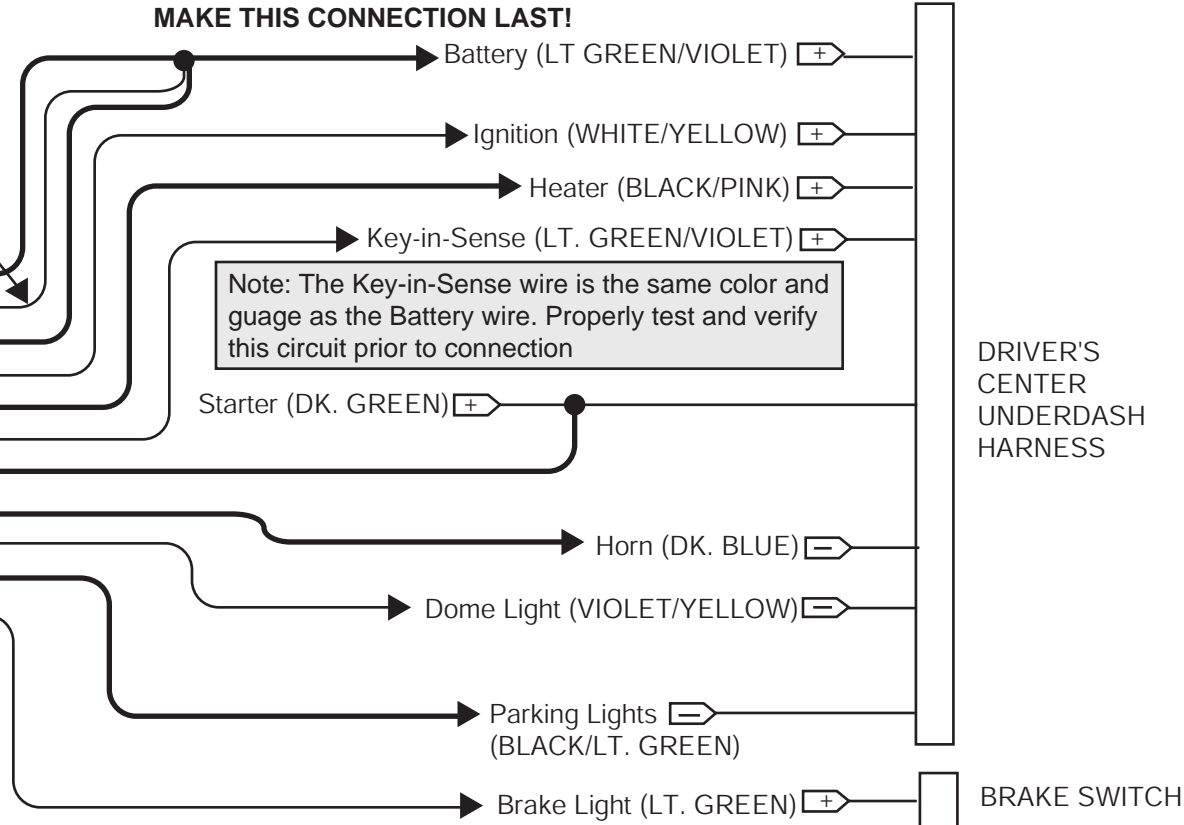

Vehicle (Year/Make/Model) '07 Mustang	
Equipment or Trim level ALL	System(s) applicable to: RKE/VSS/RMST
Page 3 of 4	Revision Date 8/18/06

	Color	Function
A-10	YELLOW/WHITE	Door Ajar Switch Input
A-2	BLUE	Door Lock Output
A-14	GREEN	Door UnLock Output
A-12	LT. GREEN	Unlock Switch Sense Input
A-11	WHITE/BLUE	Arm Input
A-9	BROWN	Disarm Input
C-4	LT GREEN/BLACK	Factory Alarm Disarm
A-24	BLUE/GREEN	Driver Door Unlock Output
C-11	BLUE/WHITE	Rear Defroster Output

Optional Installation Feature
See Optional Connections page

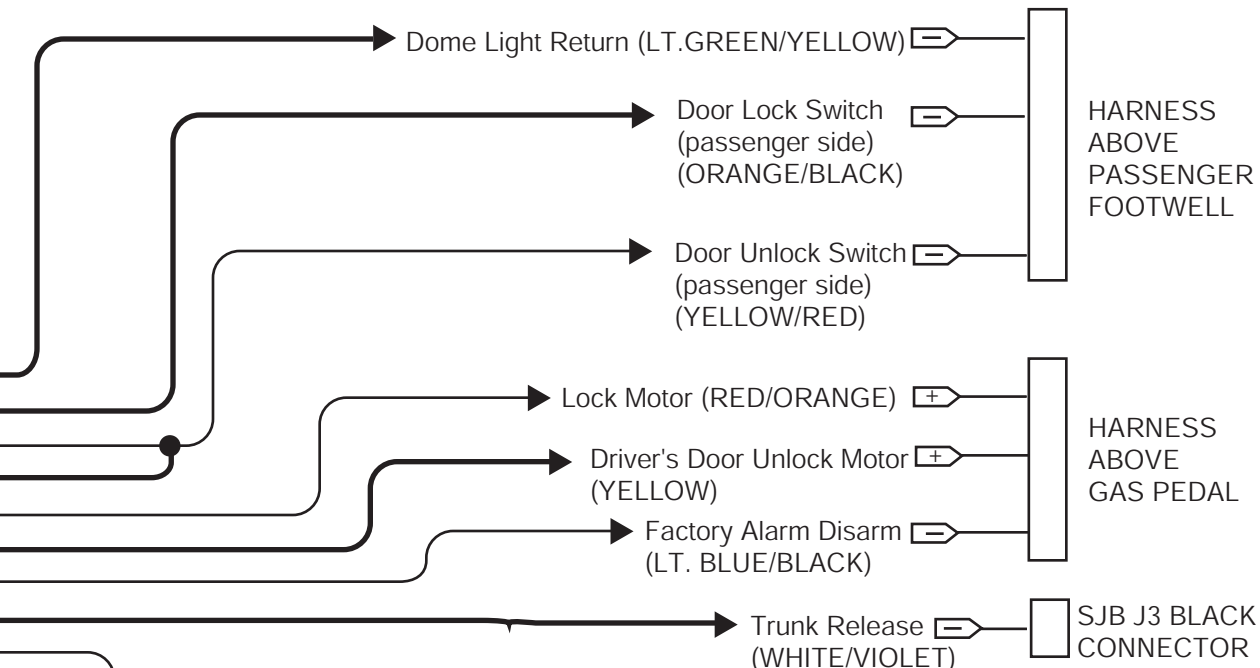

UNDERHOOD HARNESS

	Color	Function
A-19	GRAY	Hood Open Switch Input

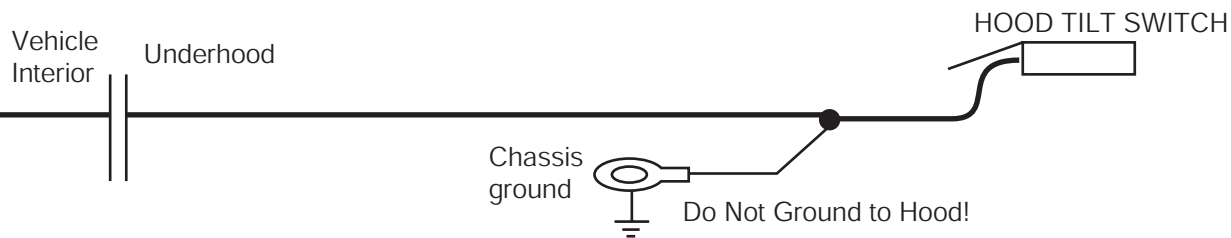

Vehicle (Year/Make/Model) '07 Mustang	
Equipment or Trim level ALL	System(s) applicable to: RKE/VSS/RMST
Page 4 of 4	Revision Date 8/18/06

OPTIONAL CONNECTIONS / FEATURES

OPTION PROGRAMMING REQUIREMENTS

BANK	OPTION	DESCRIPTION	LED
2	8	DRIVER UNLOCK RELAY	ON
3	1	DRIVER PRIORITY UNLOCK	ON

DRIVER'S DOOR PRIORITY UNLOCK

	Color	Function
C-9	TAN/RED	Driver Door Unlock Switch
A-13	TAN	Driver Door Unlock Motor
A-9	BROWN	Disarm Input

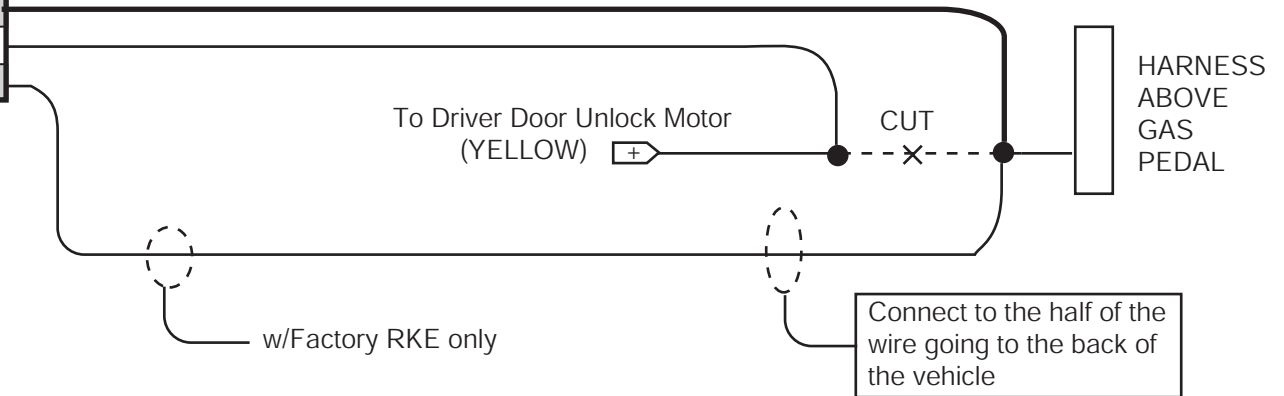

REAR DEFROSTER

	Color	Function
C-11	BLUE/WHITE	Rear Defroster Output



Vehicle (Year/Make/Model) '07 Mustang	
Equipment or Trim level ALL	System(s) applicable to: RMST
Page 1 of 2	Revision Date 8/18/06

Module:
PC-14
7L2Z-19G367-AA

FUSE PLACEMENT CHART

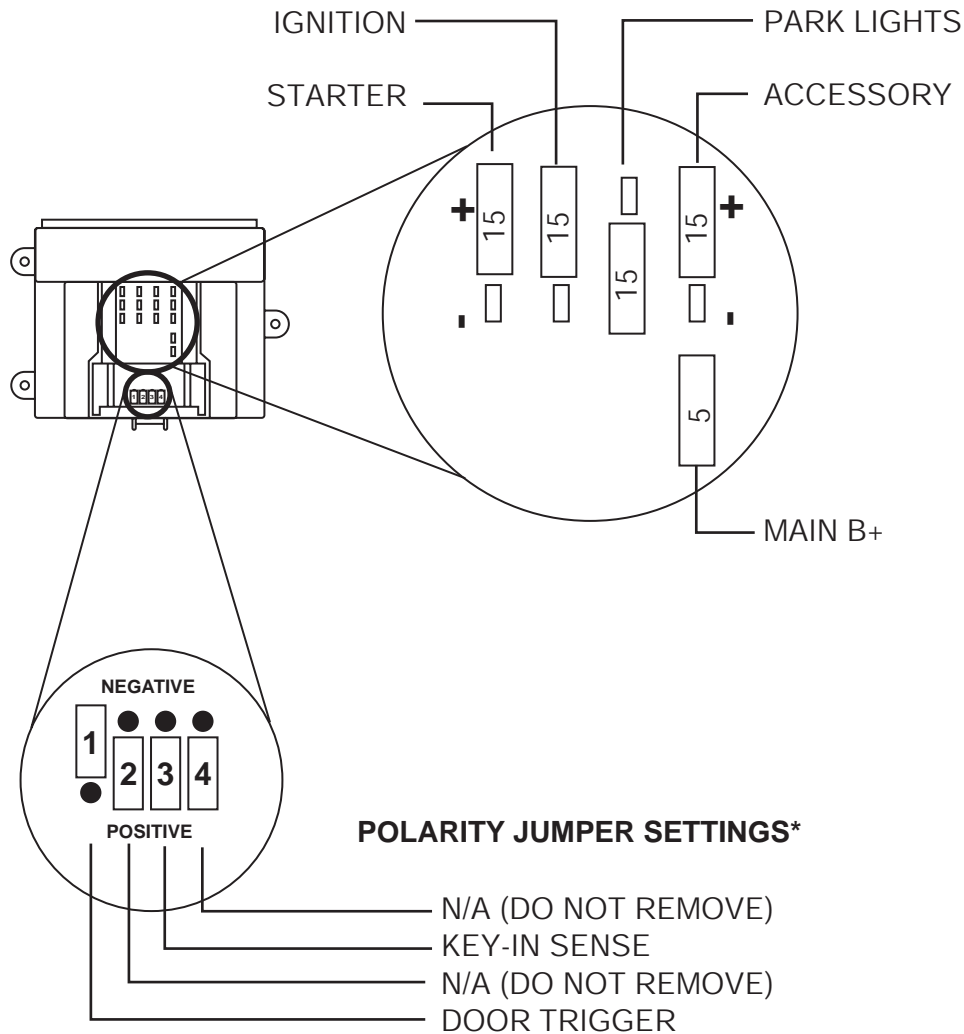

POLARITY JUMPER SETTINGS*

* See Polarity Jumper Section in Base Instructions for details

PARTS REQUIRED:

RMST Kit:
7L2Z-19G364-AA

Securilock (PATS) Interface:
PIK-4 (P/N: 7L2Z-19G365-AA - included)

FUNCTIONAL PROGRAMMING REQUIREMENTS

BANK	OPTION	DESCRIPTION	LED
1	2	DOOR AJAR INVERT	ON
1	3	KEY-IN SENSE INVERT	ON
2	1	TACHLESS MODE	ON

MODULE MOUNTING LOCATION:

Left Side of Driver's Underdash

Vehicle (Year/Make/Model) '07 Mustang	
Equipment or Trim level ALL	System(s) applicable to: RMST
Page 2 of 2	Revision Date 10/26/06

USE TYPE "A" CUSTOM WIRE HARNESS

VEHICLE HARNESS

IGNITION SWITCH

STEERING COLUMN HARNESS

	Color	Function
A-3	PINK	Ignition Input/Output
A-2	ORANGE	HVAC Output
A-13	VIOLET	Starter Output
B-8	BLACK/WHITE	Key-in-sense Input
A-4	RED	Battery

	Color	Function
A-21	BROWN/BLACK	Horn Relay Output
A-1	WHITE	Parking Light Output



Horn (DK. BLUE)

DRIVER'S CENTER UNDERDASH HARNESS

Parking Lights (BLACK/LT. GREEN)

DRIVER'S KICK PANEL HARNESS

	Color	Function
A-5	BLACK	Ground
A-24	BLUE	Door Lock Output
A-20	GREEN/VIOLET	Door Ajar Switch Input
B-7	BROWN	Brake Input

MAKE THIS CONNECTION FIRST!

CHASSIS GROUND POINT IN DRIVER'S KICK PANEL



Door Lock (ORANGE/BLACK) (passenger side)

HARNESS ABOVE PASSENGER FOOTWELL

Dome Light Return (LT. GREEN/YELLOW)

Brake (LT. GREEN)

BRAKE SWITCH

UNDER HOOD HARNESS

	Color	Function
A-19	GRAY	Hood Open Switch Input

Vehicle Interior

Engine Compartment

Hood Tilt Switch

Chassis Ground

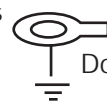

Do Not Ground to Hood!

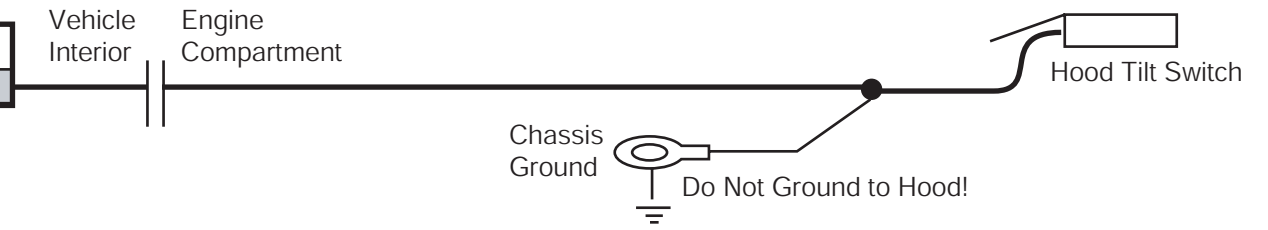

Vehicle (Year/Make/Model) '07 Mustang	
Equipment or Trim level ALL	System(s) applicable to: VSS
Page 1 of 2	Revision Date 8/18/06

Module:
PC-14
7L2Z-19G367-AA

FUSE PLACEMENT CHART

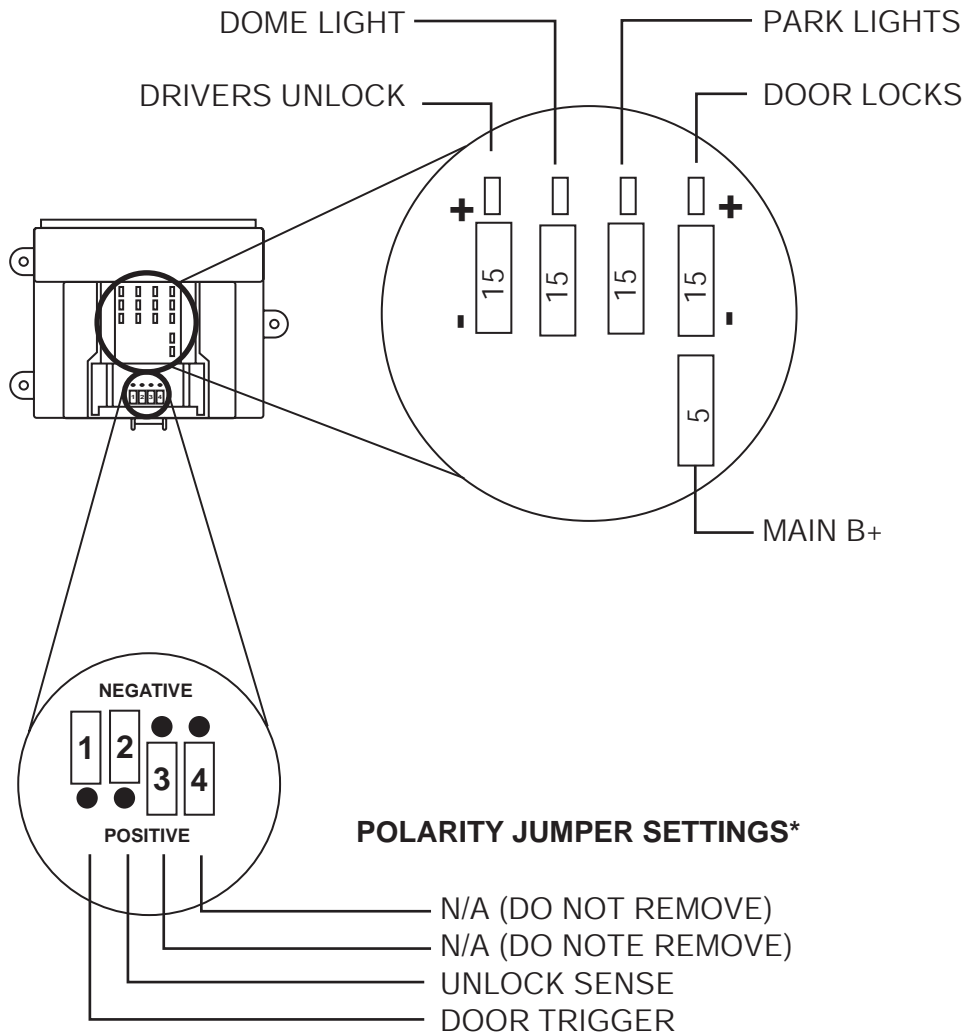

POLARITY JUMPER SETTINGS*

* See Polarity Jumper Section in Base Instructions for details

PARTS REQUIRED:

VSS Kit:
7L3Z-19A361-AA

FUNCTIONAL PROGRAMMING REQUIREMENTS

BANK	OPTION	DESCRIPTION	LED
1	1	LITE TOUCH ADJUSTMENT	note 1
1	2	FULL SHOCK ADJUSTMENT	note 1
1	4	DOOR AJAR INVERT	ON
1	5	UNLOCK SENSE INVERT	ON
2	1	STARTER INTERRUPT	OFF

Note 1: Perform proper learn procedure per the "Tach Learning" section of the Base instruction sheets.

MODULE MOUNTING LOCATION:

Left Side of Driver's Underdash

NOTE:

IF USING THIS SYSTEM IN LOT MODE, WIRE HARNESS P/N 2W7Z-19C757-BA WILL HAVE TO BE ORDERED TO ACCESS THE 'FACTORY DISARM OUTPUT" WIRE (LT.GREEN/BLACK).

Vehicle (Year/Make/Model)	
'07 Mustang	
Equipment or Trim level	System(s) applicable to:
ALL	VSS
Page	Revision Date
2 of 2	8/18/06

DRIVER'S SIDE KICK PANEL HARNESS

	Color	Function
A-5	BLACK	Ground

Note: Must Connect To Avoid False Alarms

STEERING COLUMN HARNESS

	Color	Function
A-4	RED	Battery
A-20	GREEN/VIOLET	Door Trigger Input Pull-up
A-7	PINK	Ignition 1 Input/Output
A-8	VIOLET	Starter Interrupt Motor Side
A-6	VIOLET/RED	Starter Interrupt Key Side
A-21	BROWN/BLACK	Horn Relay Output
A-3	BLACK/WHITE	Dome Light Output
A-1	WHITE	Parking Light Output

	Color	Function
A-10	YELLOW/WHITE	Door Ajar Switch Input
A-2	BLUE	Door Lock Output
A-14	GREEN	Door UnLock Output
A-12	LT. GREEN	Unlock Switch Sense Input
A-11	WHITE/BLUE	Arm Input
A-9	BROWN	Disarm Input
C-4	LT GREEN/BLACK	Factory Alarm Disarm

Connect only if system will be used in Lot Mode

MAKE THIS CONNECTION FIRST!

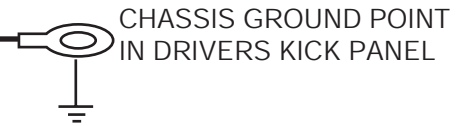

MAKE THIS CONNECTION LAST!

Note: The Battery wire is the same color and guage as the Key-in-sense wire. Properly test and verify this circuit prior to connection

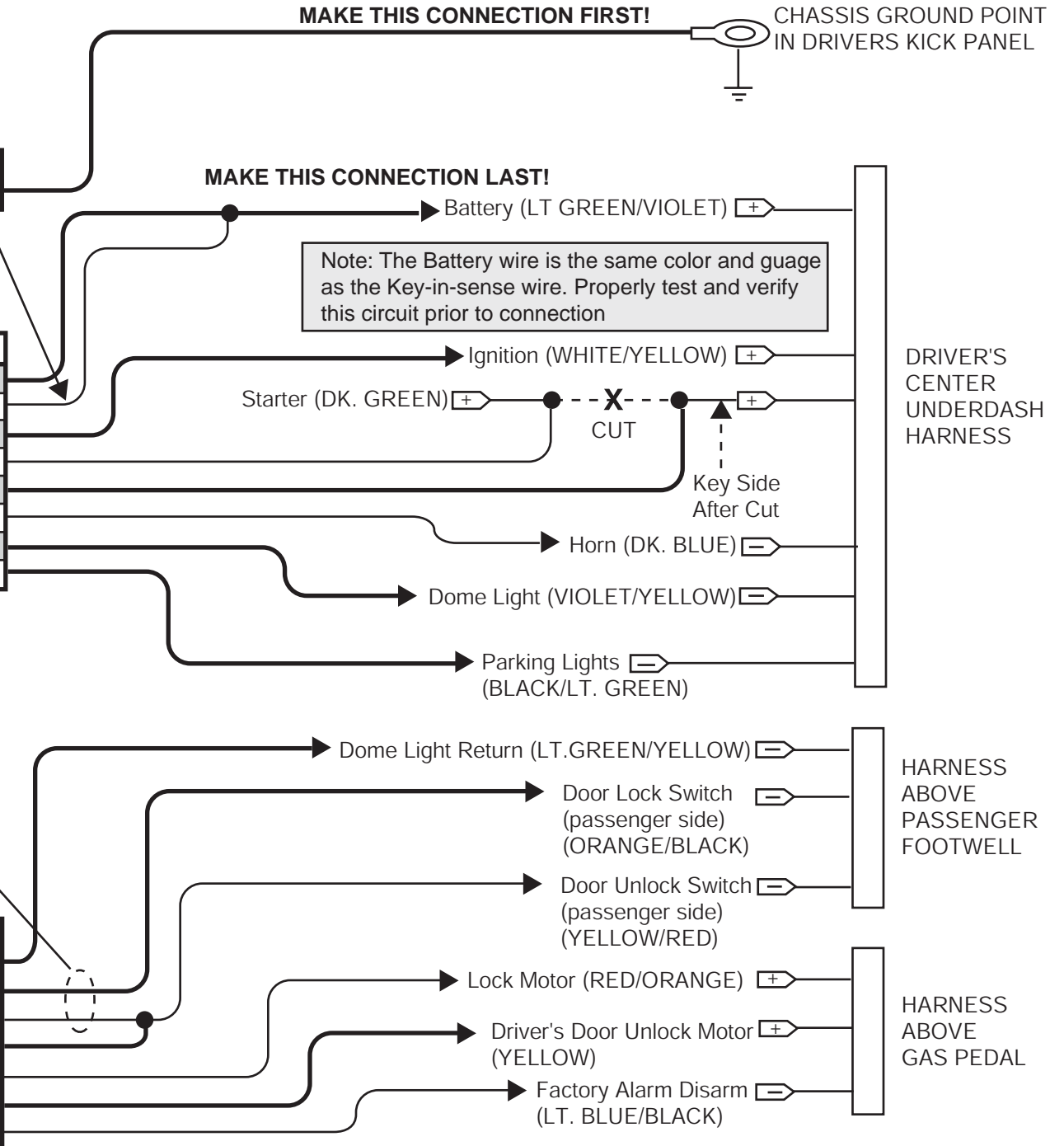

Vehicle (Year/Make/Model) '07 Mustang	
Equipment or Trim level ALL	System(s) applicable to: ALL
Page 1 of 2	Revision Date 8/18/06

S197 SJB Layout (Front View)

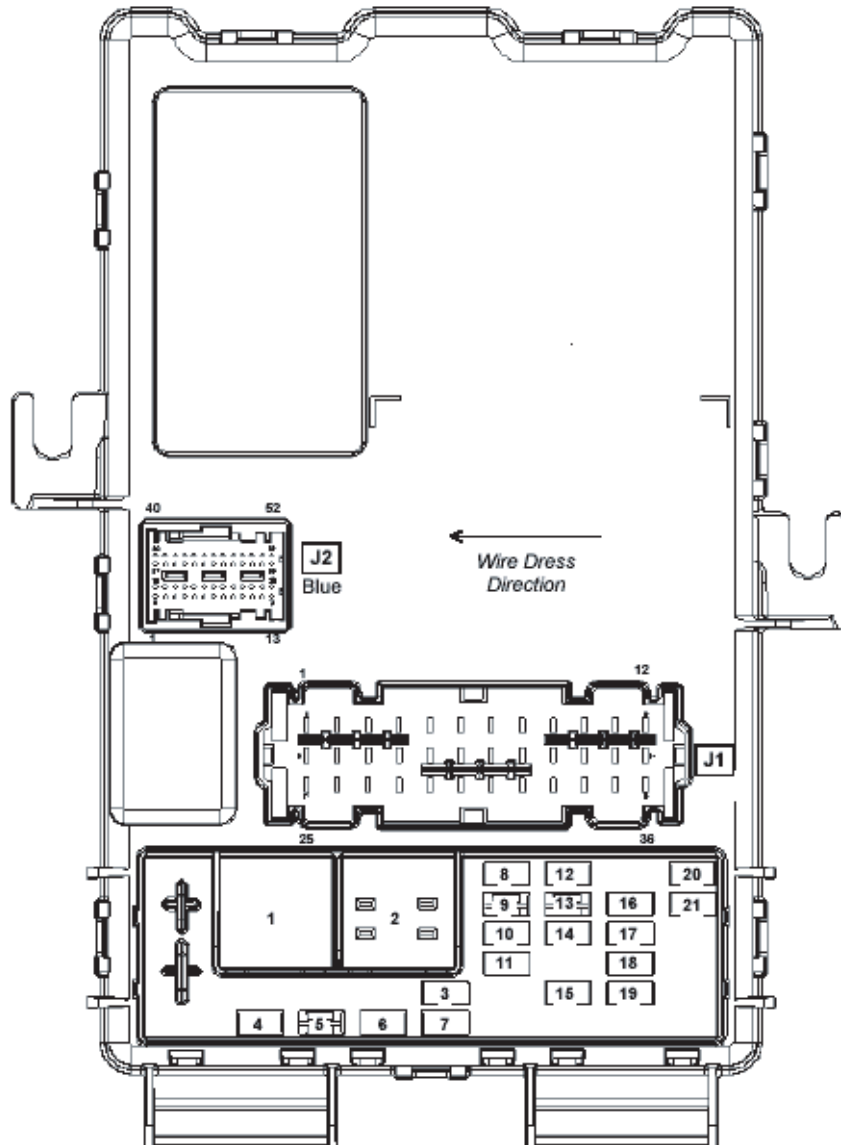

Vehicle (Year/Make/Model) '07 Mustang	
Equipment or Trim level ALL	System(s) applicable to: ALL
Page 2 of 2	Revision Date 5/3/06

S197 SJB Layout (Back View)

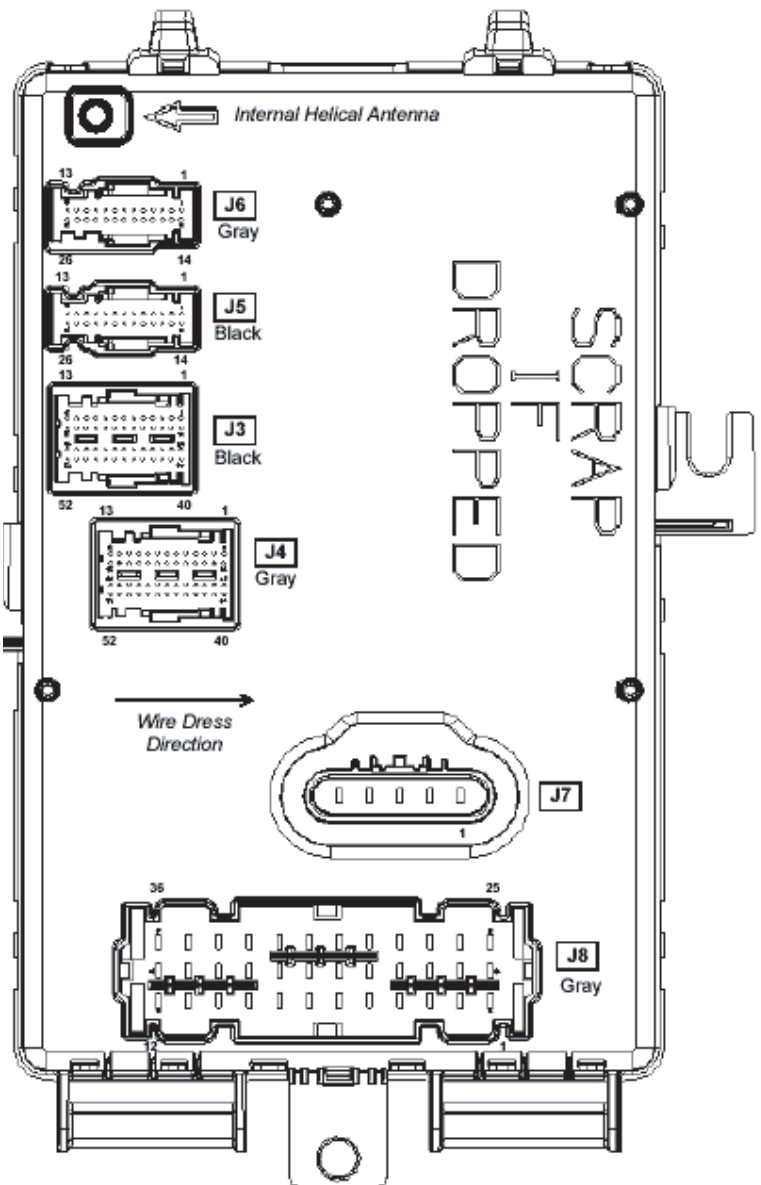

Vehicle (Year/Make/Model) '07 Towncar	
Equipment or Trim level ALL	System(s) applicable to: RKE/VSS/RMST
Page 1 of 5	Revision Date 8/18/06

Module:
PC-34
7L3Z-19G367-AA

FUSE PLACEMENT CHART

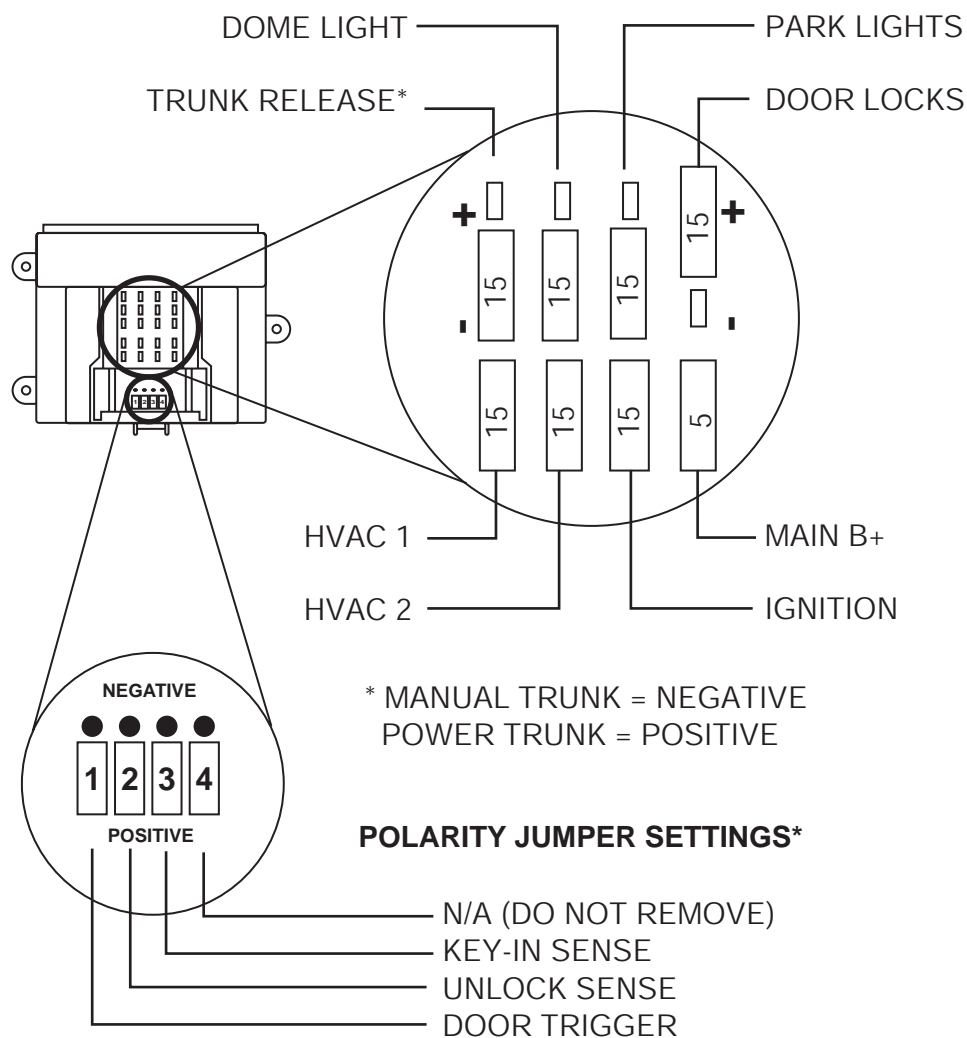

POLARITY JUMPER SETTINGS*

* See Polarity Jumper Section in Base Instructions for details

PARTS REQUIRED:

RKE/VSS/RMST Kit:

7L3Z-19G364-AA

Securilock (PATS) Interface:

PIK-4 (P/N: 7L2Z-19G365-AA - order separately)

RELAY REQUIREMENTS (P/N YL3Z-19G390-AA):

- 1- Power Window, Slider, Moonroof Interrupt Circuit
- 1- Driver Door Unlock or Trunk Release (optional)
- 2- Memory Seats (optional)

FUNCTIONAL PROGRAMMING REQUIREMENTS

BANK	OPTION	DESCRIPTION	LED
1	1	LITE TOUCH ADJUSTMENT	note 1
1	2	FULL SHOCK ADJUSTMENT	note 1
1	4	DOOR AJAR INVERT	ON
1	5	UNLOCK SENSE INVERT	ON
1	6	KEY-IN SENSE INVERT	ON
2	1	STARTER INTERRUPT	OFF
2	8	DRIVER UNLOCK RELAY	note 2
3	1	DRIVER PRIORITY UNLOCK	note 2
4	1	TACHLESS MODE	ON

Note 1: Perform proper adjustments per the "Shock Sensor Setting" section of the Base instruction sheets.

Note 2: See the Optional Connections / Features page

MODULE MOUNTING LOCATION:

Left Side of Driver's Underdash

Vehicle (Year/Make/Model) '07 Towncar	
Equipment or Trim level ALL	System(s) applicable to: RKE/VSS/RMST
Page 2 of 5	Revision Date 5/30/06

STEERING COLUMN HARNESS

	Color	Function
A-4	RED	Battery
B-1	BLUE	HVAC2 Feed
B-2	RED	HVAC 1 Battery Feed
A-7	PINK	Ignition 1 Input/Output
B-4	ORANGE	HVAC 1 Output
B-5	ORANGE/WHITE	HVAC 2 Output
A-8	VIOLET	Starter Output
B-8	BLACK/WHITE	Key-in-sense Input
A-21	BROWN/BLACK	Horn Relay Output
A-1	WHITE	Parking Light Output
A-3	BLACK/WHITE	Dome Light Output
A-20	GREEN/VIOLET	Door Ajar Switch Input
B-7	BROWN	Brake Input
C-10	RED/WHITE	Headlight Output
C-11	BLUE/WHITE	Rear Defroster Output

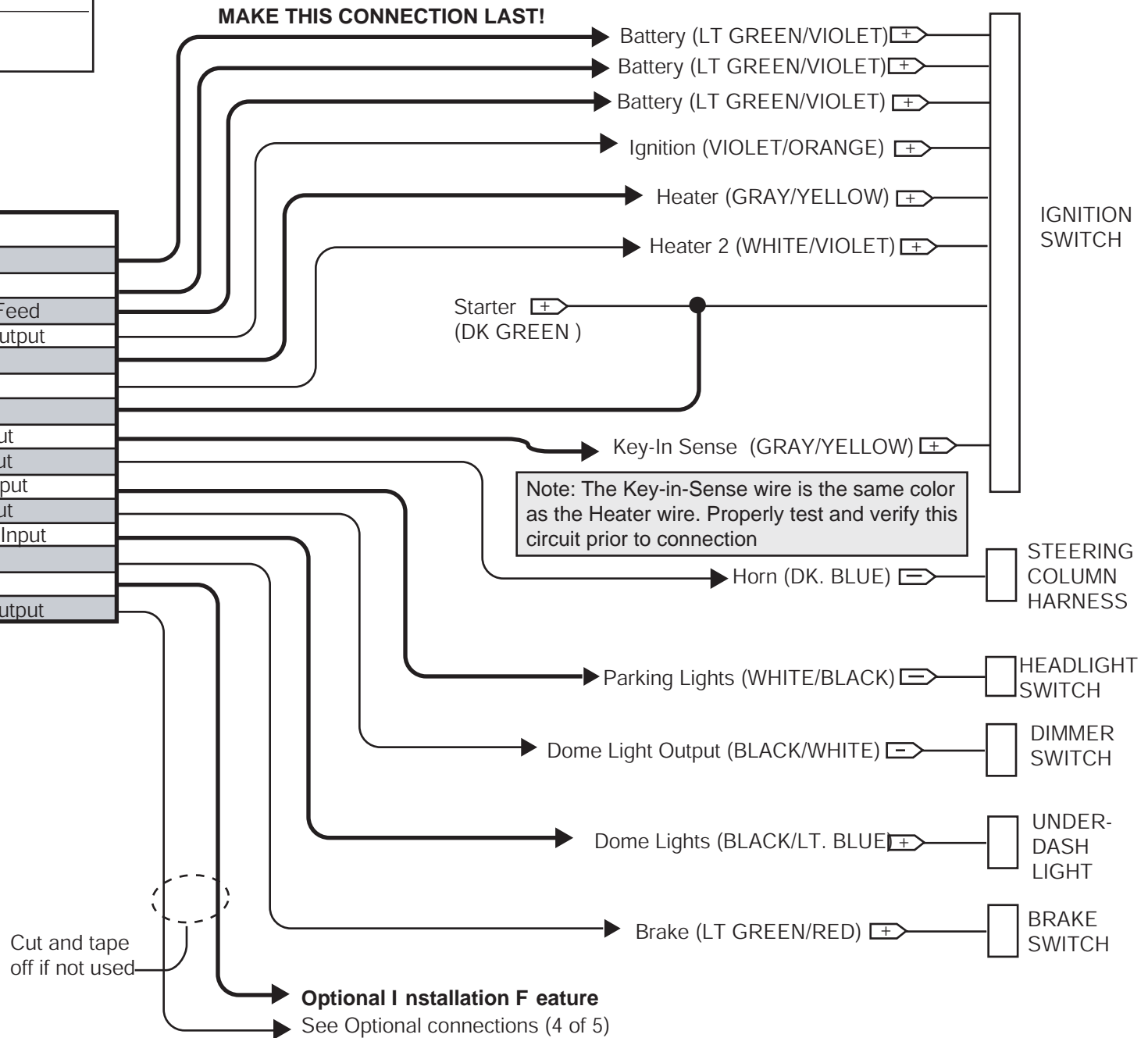

Vehicle (Year/Make/Model) '07 Towncar	
Equipment or Trim level ALL	System(s) applicable to: RKE/VSS/RMST
Page 3 of 5	Revision Date 5/30/06

DRIVER'S KICK PANEL HARNESS

	Color	Function
A-5	BLACK	Ground
A-9	BROWN	Disarm Input
A-11	WHITE/BLUE	Arm Input
A-12	LT GREEN	Unlock Switch Sense
A-14	GREEN	Door Unlock Output
A-2	BLUE	Door Lock Output
A-13	TAN	Trunk Release
C-4	LT GREEN/BLACK	Factory Alarm Disarm Output
A-24	BLUE/GREEN	Driver Door Unlock Output

MAKE THIS CONNECTION FIRST!

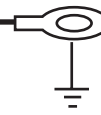

CHASSIS GROUND POINT
IN DRIVER'S KICK PANEL

Optional Installation Feature
See Optional connections (4 of 5)

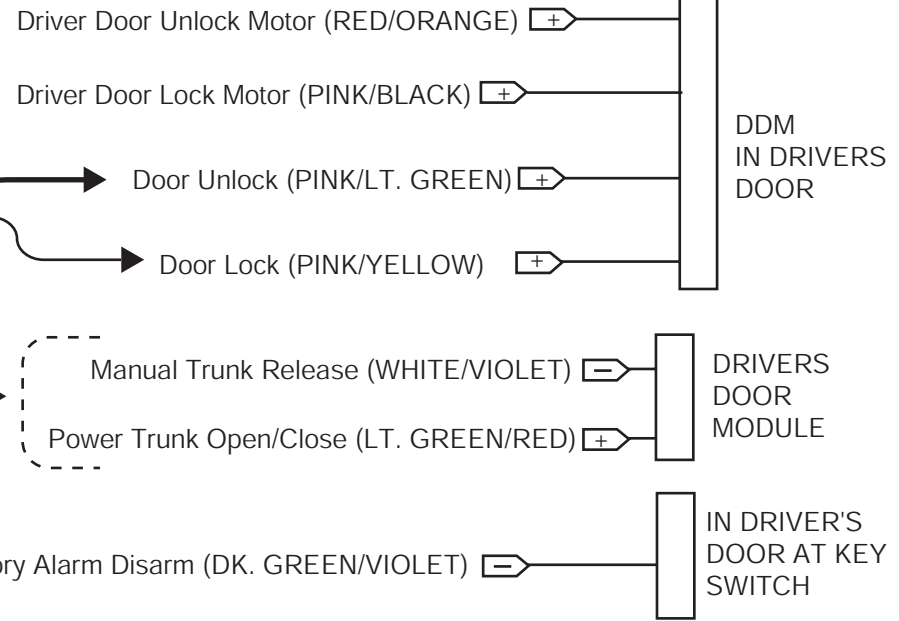

CONNECTIONS UNDER HOOD

	Color	Function
A-19	GRAY	Hood Open Switch Input

Vehicle Interior

Engine Compartment



Vehicle (Year/Make/Model) '07 Towncar	
Equipment or Trim level ALL	System(s) applicable to: RKE/VSS/RMST
Page 4 of 5	Revision Date 5/30/06

OPTIONAL CONNECTIONS / FEATURES

DRIVER'S DOOR UNLOCK

	Color	Function
A-24	BLUE/GREEN	Driver Door Unlock Output
A-9	BROWN	Disarm Input

OPTION PROGRAMMING REQUIREMENTS

BANK	OPTION	DESCRIPTION	LED
3	1	DRIVER PRIORITY UNLOCK	ON

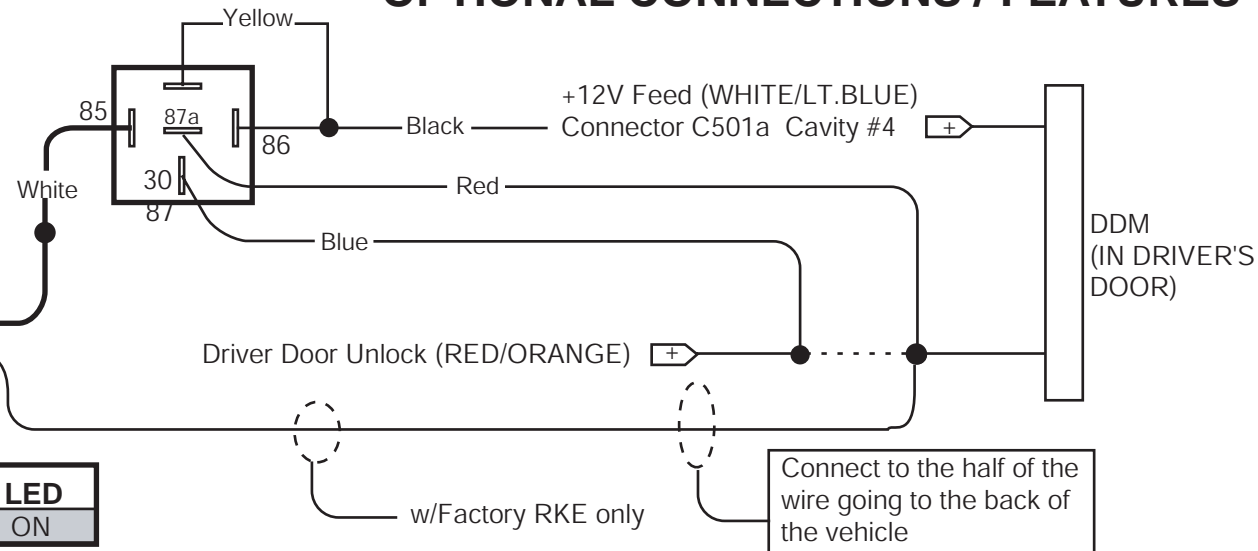

HEADLIGHTS/REAR DEFROSTER

	Color	Function
C-10	RED/WHITE	Headlight Output
C-11	BLUE/WHITE	Rear Defroster Output

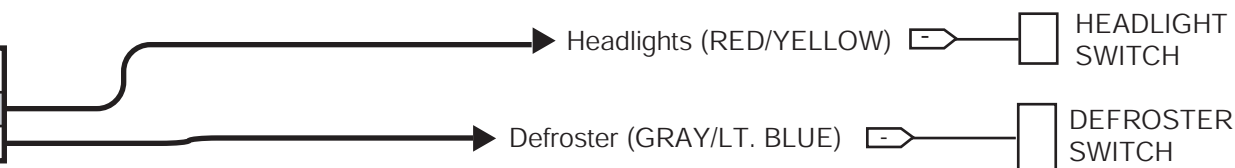

IMPORTANT!

The relay wire colors shown here, are the colors used on the FORD accessory relay kits listed above. Wire colors on other relays may be different!

POWER OPTIONS

	Color	Function
C-12	GREEN/WHITE	Memory Seat 1
C-13	YELLOW/GREEN	Memory Seat 2

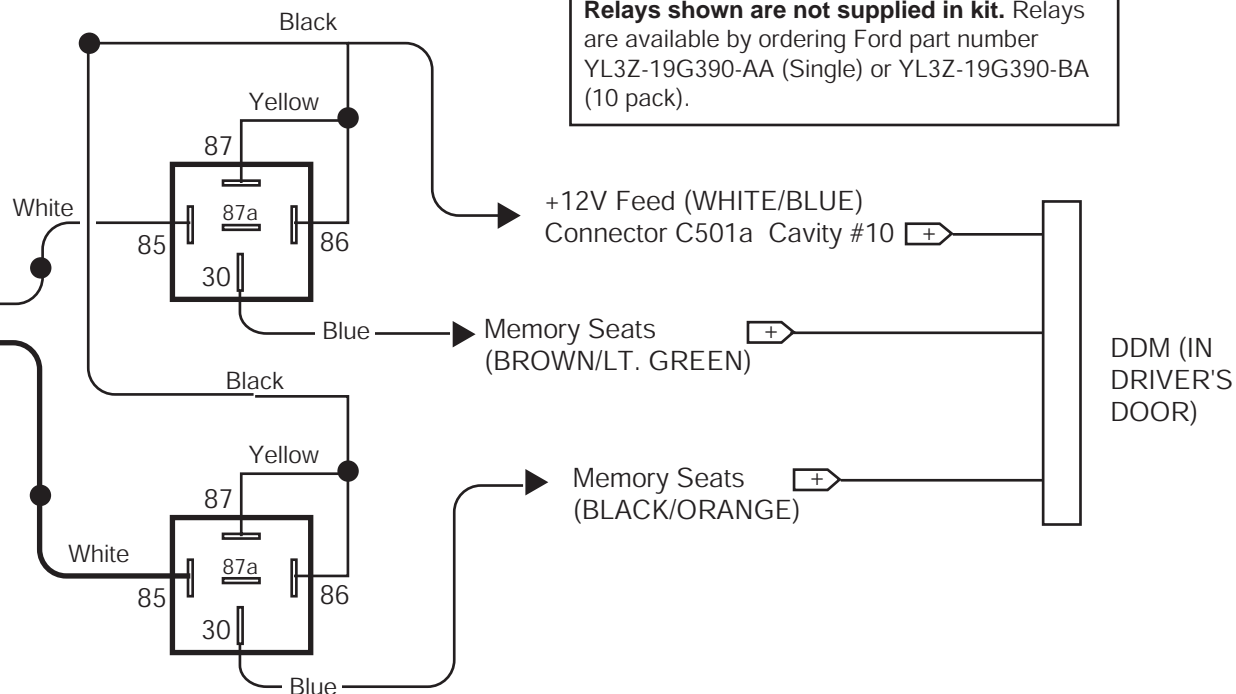

Relays shown are not supplied in kit. Relays are available by ordering Ford part number YL3Z-19G390-AA (Single) or YL3Z-19G390-BA (10 pack).

Vehicle (Year/Make/Model)	
'07 Towncar	
Equipment or Trim level	System(s) applicable to:
ALL	RKE/VSS/RMST
Page	Revision Date
5 of 5	5/30/06

POWER WINDOW / MOONROOF INTERRUPTS

NOTE: CUTTING THIS WIRE WILL DISABLE ALL POWER WINDOWS AND MOONROOF

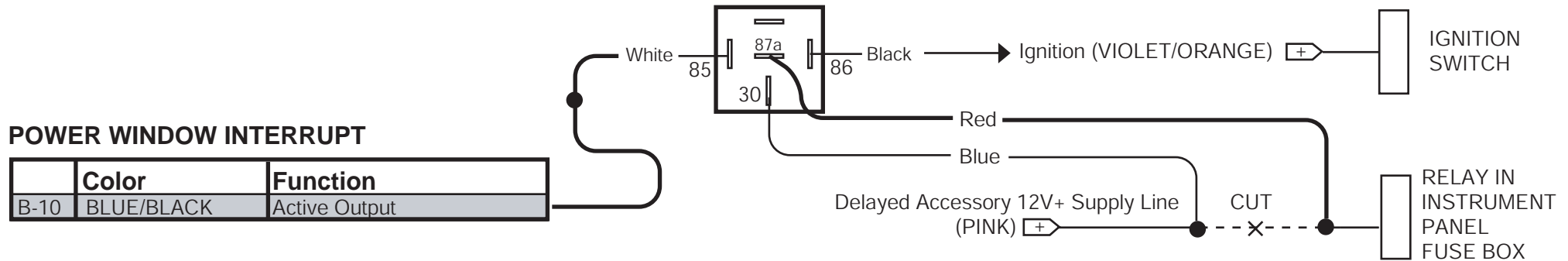

CAUTION: REMOVE YELLOW WIRE AND TERMINAL FROM RELAY SOCKET

Relays shown are not supplied in kit. Relays are available by ordering Ford part number YL3Z-19G390-AA (Single) or YL3Z-19G390-BA (10 pack).

Vehicle (Year/Make/Model) '07 Towncar	
Equipment or Trim level ALL	System(s) applicable to: RMST
Page 1 of 3	Revision Date 8/18/06

Module:
PC-34
7L3Z-19G367-AA

FUSE PLACEMENT CHART

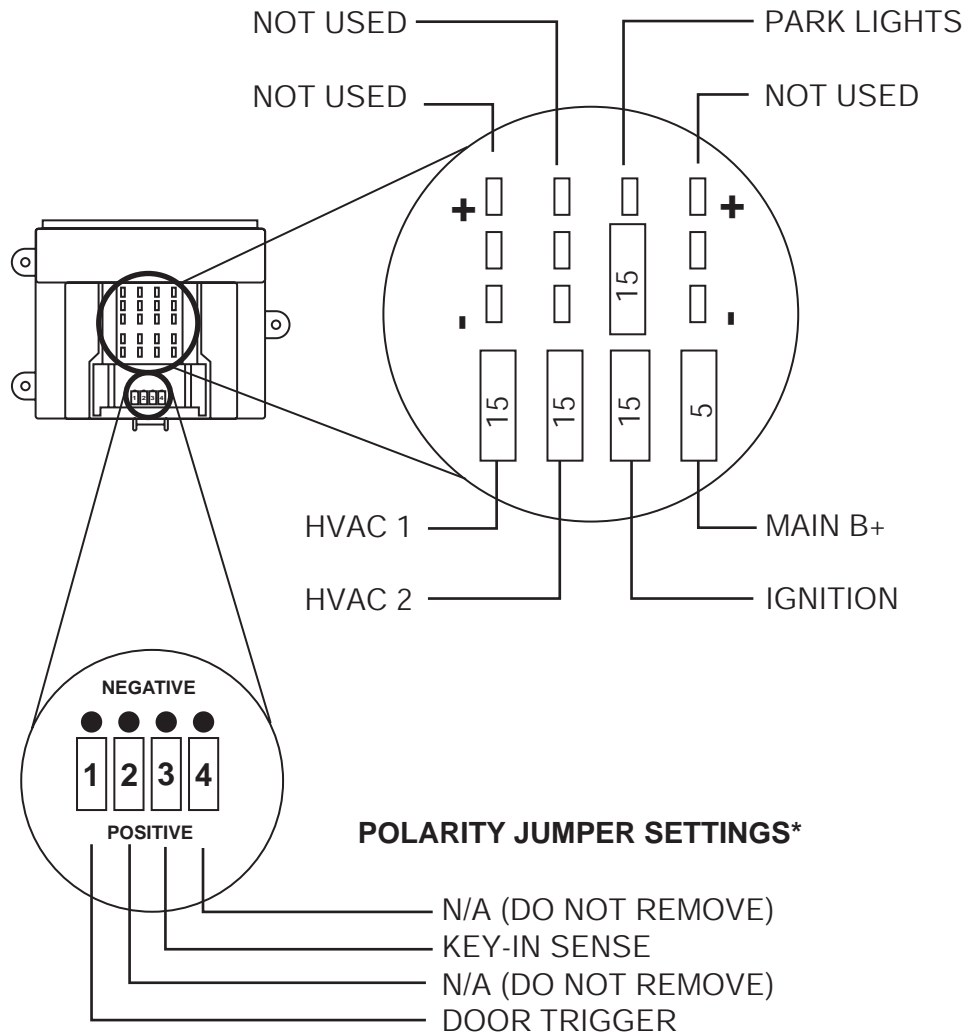

* See Polarity Jumper Section in Base Instructions for details

PARTS REQUIRED:

RMST Kit:
7W3Z-19G364-AA

Securilock (PATS) Interface:
PIK-4 (P/N: 7L2Z-19G365-AA)

RELAY REQUIREMENTS (P/N YL3Z-19G390-AA):
1- Power Window, Slider, Moonroof Interrupt Circuit

FUNCTIONAL PROGRAMMING REQUIREMENTS

BANK	OPTION	DESCRIPTION	LED
1	2	DOOR AJAR INVERT	ON
1	3	KEY-IN SENSE INVERT	ON
2	1	TACHLESS MODE	ON

MODULE MOUNTING LOCATION:
Left Side of Driver's Underdash

Vehicle (Year/Make/Model) '07 Towncar	
Equipment or Trim level ALL	System(s) applicable to: RMST
Page 2 of 3	Revision Date 5/30/06

USE TYPE "C" CUSTOM WIRE HARNESS

VEHICLE HARNESS

IGNITION SWITCH

STEERING COLUMN HARNESS

	Color	Function
A-7	PINK	Ignition Input/Output
B-3	PINK/WHITE	Ignition 2 Output
B-4	ORANGE	HVAC 1 Output
B-5	ORANGE/WHITE	HVAC 2 Output
A-6	VIOLET	Starter Interrupt (Key Side)
A-8	VIOLET	Starter Interrupt (Motor Side)
A-4	RED	Battery
B-2	RED	Battery
B-1	BLUE	Battery
B-8	BLACK/WHITE	Key-In Sense Input

	Color	Function
A-21	BROWN/BLACK	Horn Relay Output
A-1	WHITE	Parking Light Output

DRIVER'S KICK PANEL HARNESS

	Color	Function
A-5	BLACK	Ground
A-24	BLUE	Door Lock Output
B-7	BROWN	Brake Input
A-20	GREEN/VIOLET	Door Ajar Switch Input

UNDER HOOD HARNESS

	Color	Function
A-19	GRAY	Hood Open Switch Input

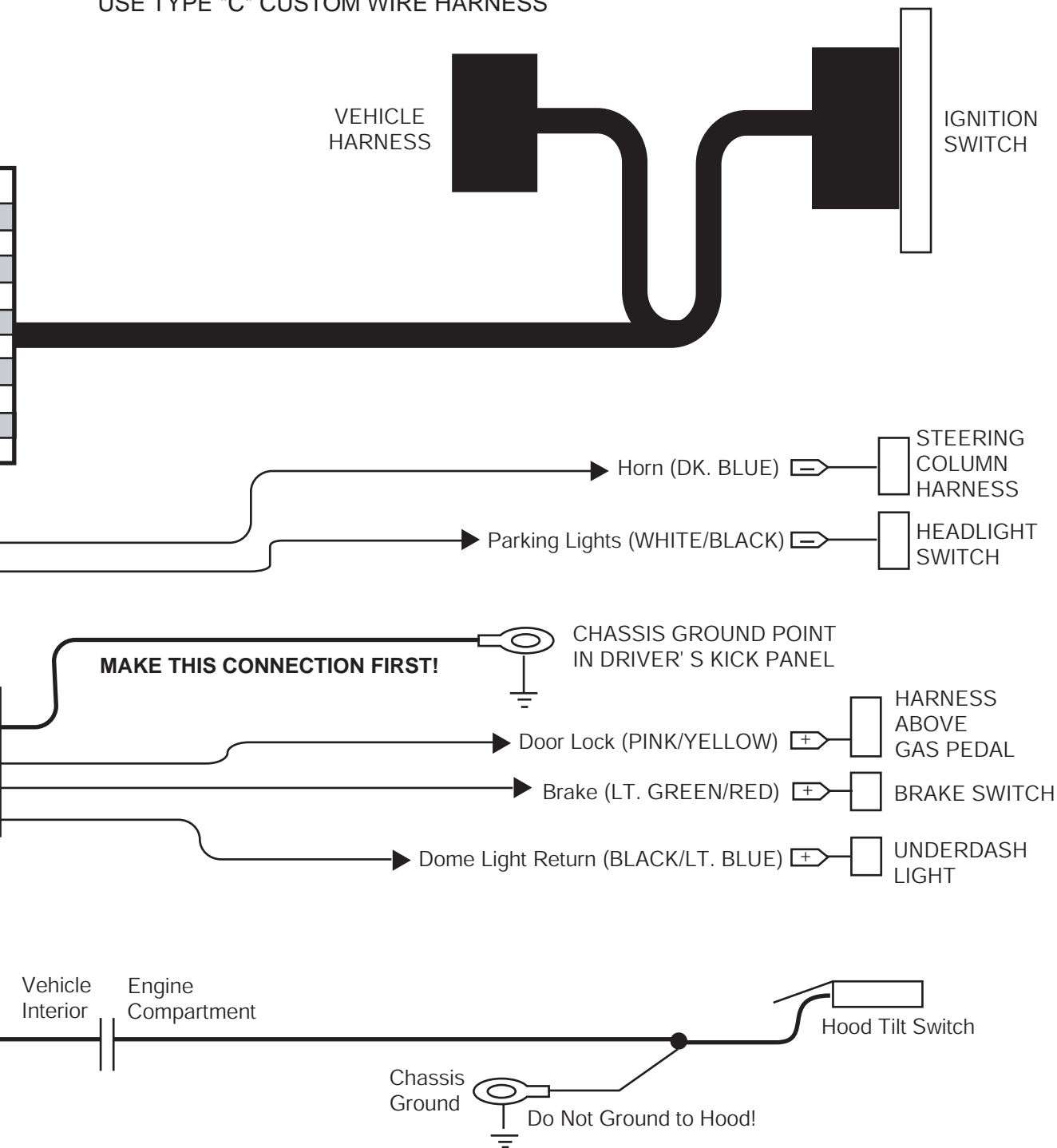

Vehicle (Year/Make/Model) '07 Towncar	
Equipment or Trim level ALL	System(s) applicable to: RMST
Page 3 of 3	Revision Date 5/30/06

POWER WINDOW / MOONROOF INTERRUPTS

NOTE: CUTTING THIS WIRE WILL DISABLE ALL POWER WINDOWS AND MOONROOF

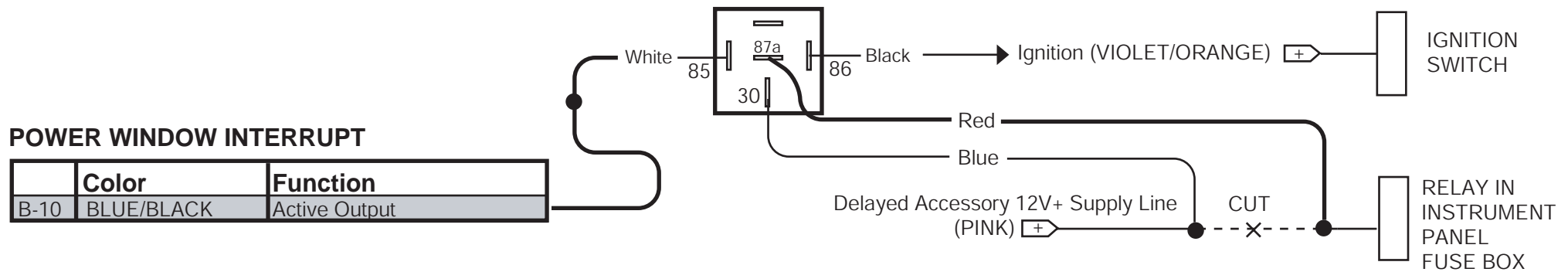

CAUTION: REMOVE YELLOW WIRE AND TERMINAL FROM RELAY SOCKET

Relays shown are not supplied in kit. Relays are available by ordering Ford part number YL3Z-19G390-AA (Single) or YL3Z-19G390-BA (10 pack).

Vehicle (Year/Make/Model) '07 Towncar	
Equipment or Trim level ALL	System(s) applicable to: VSS
Page 1 of 2	Revision Date 5/30/06

Module:
PC-14
7L2Z-19G367-AA

FUSE PLACEMENT CHART

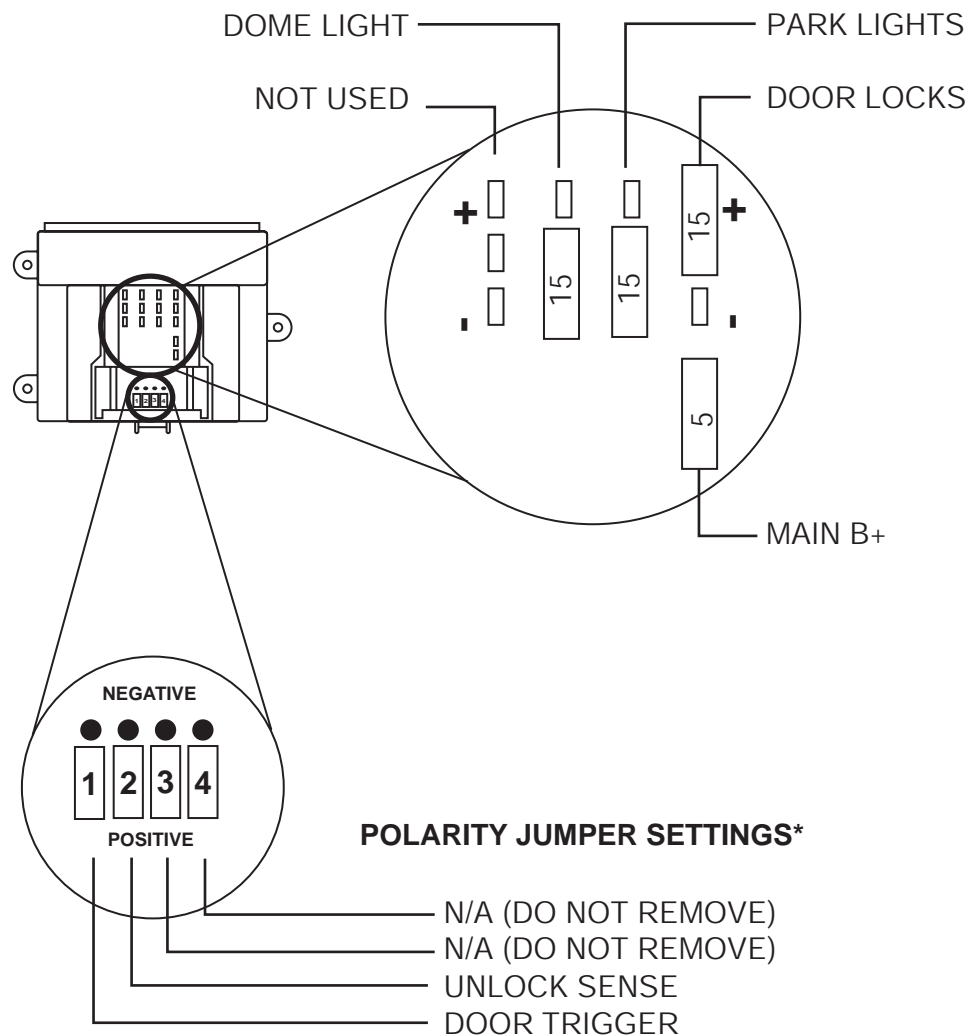

* See Polarity Jumper Section in Base Instructions for details

PARTS REQUIRED:

VSS Kit:
7L3Z-19A361-AA

FUNCTIONAL PROGRAMMING REQUIREMENTS

BANK	OPTION	DESCRIPTION	LED
1	1	LITE TOUCH ADJUSTMENT	note 1
1	2	FULL SHOCK ADJUSTMENT	note 1
1	4	DOOR AJAR INVERT	ON
1	5	UNLOCK SENSE INVERT	ON
2	1	STARTER INTERRUPT	OFF

Note 1: Perform proper adjustments per the "Shock Sensor Setting" section of the Base instruction sheets.

MODULE MOUNTING LOCATION:

Left Side of Driver's Underdash

NOTE:

IF USING THIS SYSTEM IN LOT MODE, WIRE HARNESS P/N 2W7Z-19C757-BA WILL HAVE TO BE ORDERED TO ACCESS THE 'FACTORY DISARM OUTPUT" WIRE (LT.GREEN/BLACK).

Vehicle (Year/Make/Model)	
'07 Towncar	
Equipment or Trim level	System(s) applicable to:
ALL	VSS
Page	Revision Date
2 of 2	5/30/06

STEERING COLUMN HARNESS

	Color	Function
A-4	RED	Battery
A-7	PINK	Ignition Input
A-8	VIOLET	Starter Interrupt (Motor side)
A-6	VIOLET/RED	Starter Interrupt (Key side)
A-21	BROWN/BLACK	Horn Relay Output
A-1	WHITE	Parking Light Output
A-20	GREEN/VIOLET	Door Ajar Switch Input

MAKE THIS CONNECTION LAST!

Connect only if system will be used in Lot Mode

MAKE THIS CONNECTION FIRST!

Connect only if system will be used in Lot Mode

DRIVER'S KICK PANEL HARNESS

	Color	Function
A-5	BLACK	Ground
A-2	BLUE	Door Lock Output
A-14	GREEN	Door Unlock Output
A-11	WHITE/BLUE	Arm Input
A-9	BROWN	Disarm Input
A-12	WHITE/BLUE	Unlock Switch Sense

	Color	Function
C-4	LT.GREEN/BLACK	Factory Alarm Disarm Output

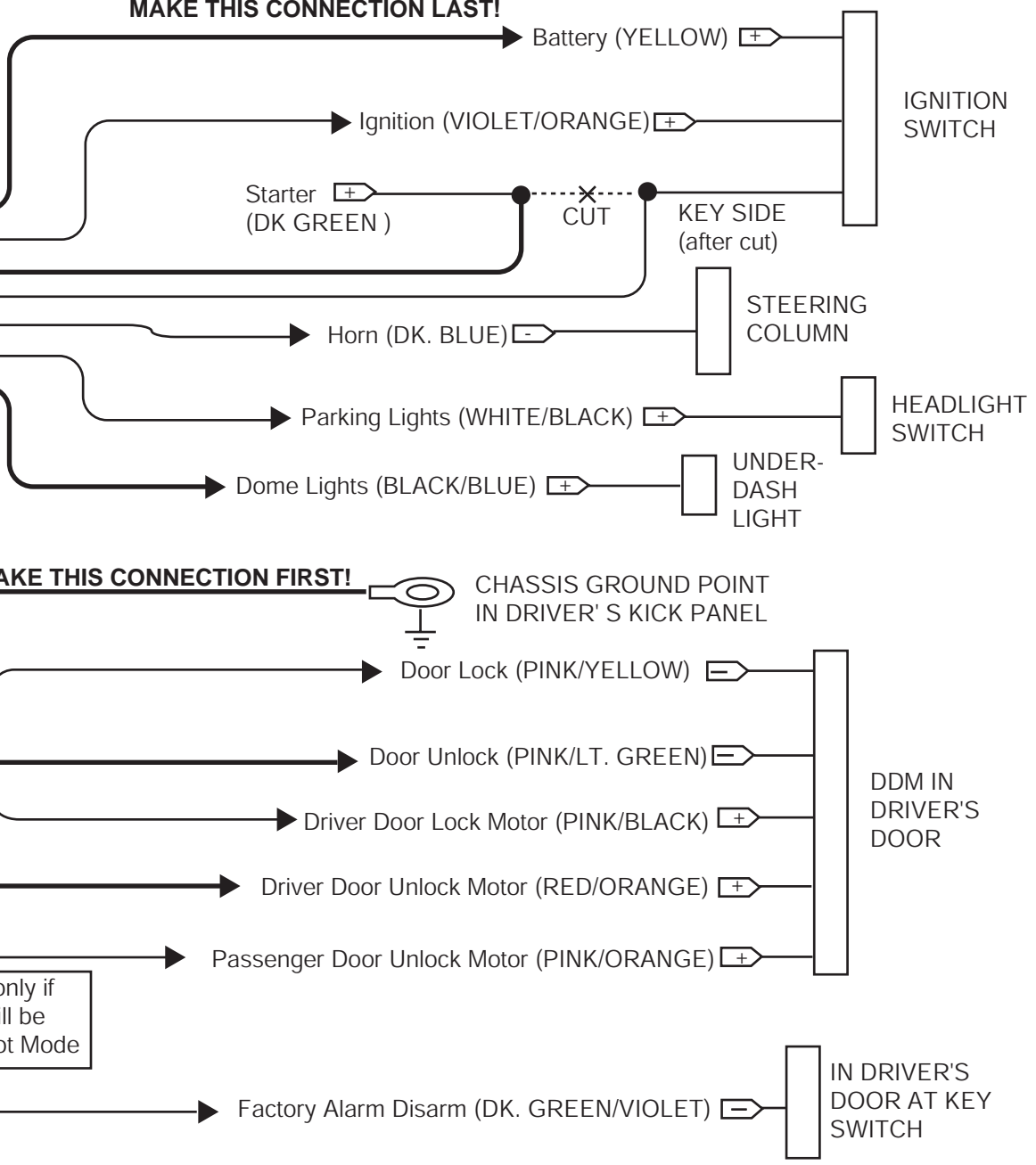

Vehicle (Year/Make/Model) '07 Crown Vic/Grand Marquis	
Equipment or Trim level ALL	System(s) applicable to: RKE/VSS/RMST
Page 1 of 6	Revision Date 8/1806

Module:
PC-34
7L3Z-19G367-AA

FUSE PLACEMENT CHART

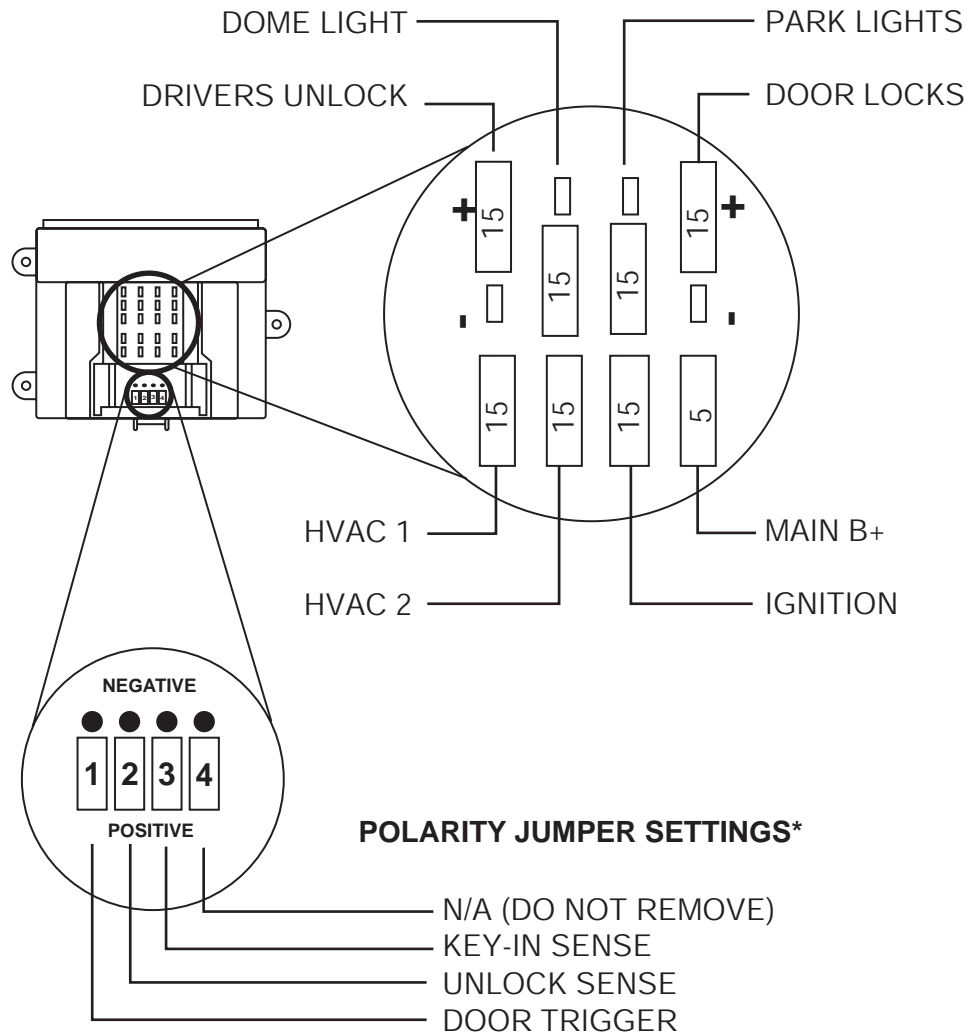

POLARITY JUMPER SETTINGS*

* See Polarity Jumper Section in Base Instructions for details

PARTS REQUIRED:

RKE/VSS/RMST Kit:
7L3Z-19G364-AA

Securilock (PATS) Interface:
PIK-4 (P/N: 7L2Z-19G365-AA - order separately)

RELAY REQUIREMENTS (P/N YL3Z-19G390-AA):
2- Power Window, Moonroof Interrupt Circuit
1- Trunk Release or Drivers Door Unlock (optional)

FUNCTIONAL PROGRAMMING REQUIREMENTS

BANK	OPTION	DESCRIPTION	LED
1	1	LITE TOUCH ADJUSTMENT	note 1
1	2	FULL SHOCK ADJUSTMENT	note 1
1	4	DOOR AJAR INVERT	ON
1	5	UNLOCK SENSE INVERT	ON
1	6	KEY-IN SENSE INVERT	ON
2	1	STARTER INTERRUPT	OFF
2	8	DRIVER UNLOCK RELAY	note 2
3	1	DRIVER PRIORITY UNLOCK	note 2
4	1	TACHLESS MODE	ON

Note 1: Perform proper adjustments per the "Shock Sensor Setting" section of the Base instruction sheets.

Note 2: See the Optional Connections / Features page

MODULE MOUNTING LOCATION:
Left Side of Driver's Underdash

Vehicle (Year/Make/Model)	
'07 Crown Vic/Grand Marquis	
Equipment or Trim level	System(s) applicable to:
ALL	RKE/VSS/RMST
Page	Revision Date
2 of 6	6/8/06

STEERING COLUMN HARNESS

	Color	Function
A-4	RED	Battery
B-1	BLUE	HVAC2 Feed
B-2	RED	HVAC 1 12 volt Battery Feed
A-7	PINK	Ignition 1 Input/Output
B-4	ORANGE	HVAC 1 Output
B-5	ORANGE/WHITE	HVAC 2 Output
A-8	VIOLET	Starter Output
B-8	BLACK/WHITE	Key-in-sense Input
A-21	BROWN/BLACK	Horn Relay Output
A-1	WHITE	Parking Light Output
A-3	BLACK/WHITE	Dome Light Output
A-20	GREEN/VIOLET	Door Ajar Switch Input
B-7	BROWN	Brake Input
C-10	RED/WHITE	Headlight Output
C-11	BLUE/WHITE	Rear Defroster Output

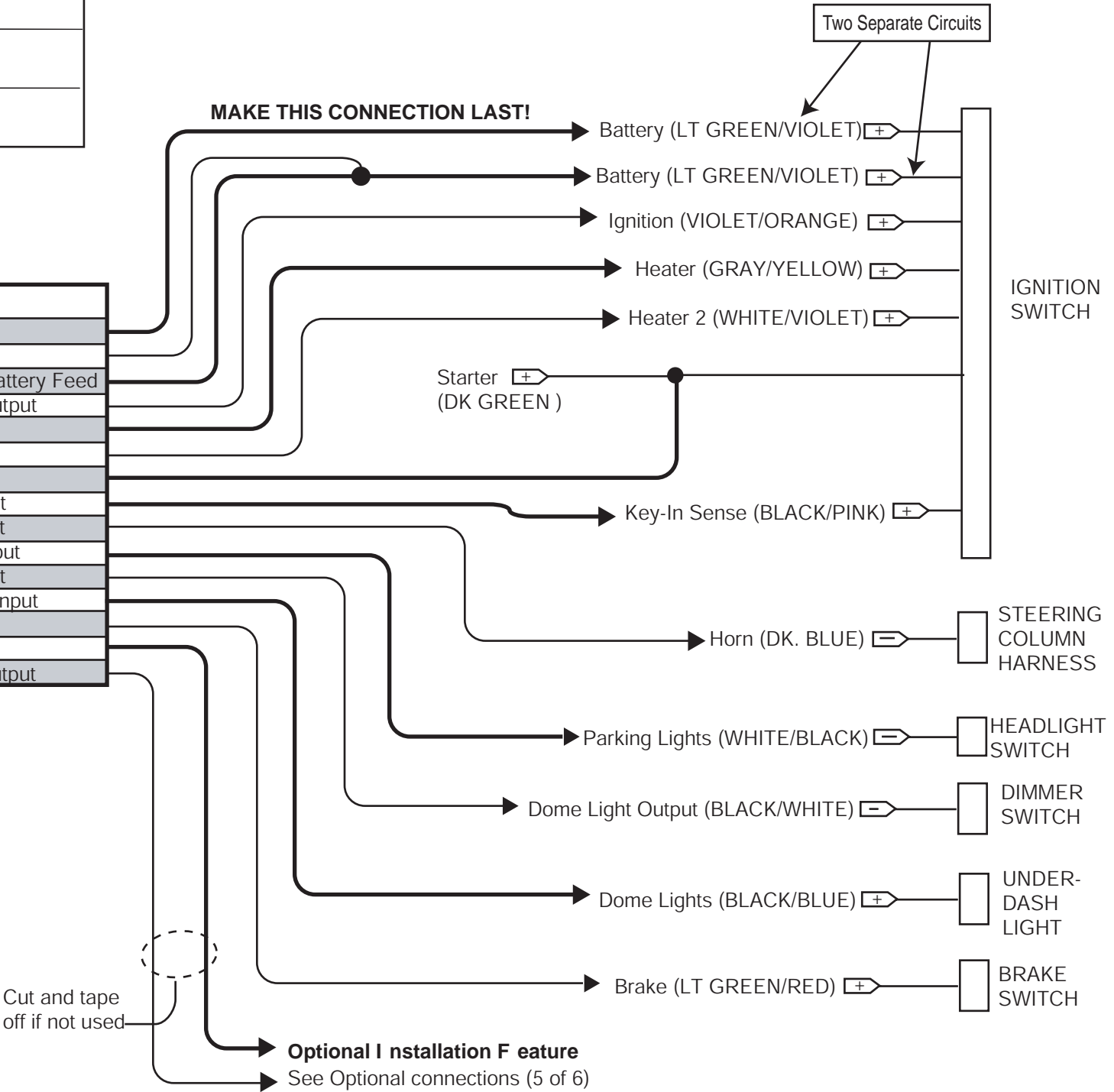

Vehicle (Year/Make/Model)	
'07 Crown Vic/Grand Marquis	
Equipment or Trim level	System(s) applicable to:
W/Factory RKE	RKE/VSS/RMST
Page	Revision Date
3 of 6	6/8/06

DRIVER'S KICK PANEL HARNESS

	Color	Function
A-5	BLACK	Ground
A-9	BROWN	Disarm Input
A-11	WHITE/BLUE	Arm Input
A-12	LT GREEN	Unlock Switch Sense
A-14	GREEN	Door Unlock Output
A-2	BLUE	Door Lock Output
A-24	BLUE/GREEN	Trunk Release Output
C-4	LT GREEN/BLACK	Factory Alarm Disarm Output

MAKE THIS CONNECTION FIRST!

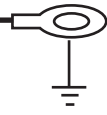

CHASSIS GROUND POINT
IN DRIVER'S KICK PANEL

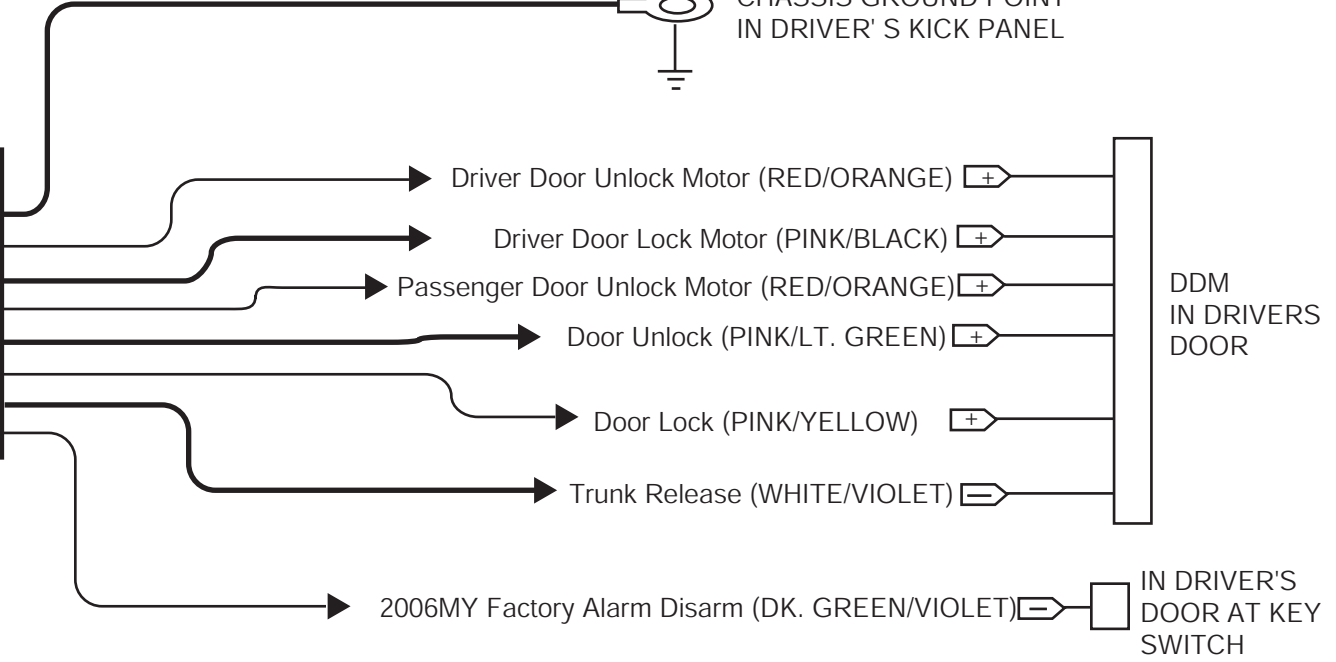

CONNECTIONS UNDER HOOD

	Color	Function
A-19	GRAY	Hood Open Switch Input

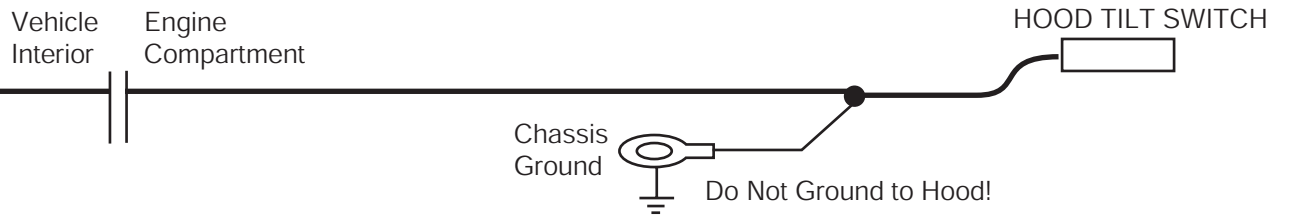

Vehicle (Year/Make/Model)	
'07 Crown Vic/Grand Marquis	
Equipment or Trim level	System(s) applicable to:
w/o Factory RKE	RKE/VSS/RMST
Page	Revision Date
4 of 6	6/8/06

DRIVERS SIDE KICK PANEL HARNESS

	Color	Function
A-5	BLACK	Ground
C-1	BLUE/BLACK	Door Lock Switch Side
A-2	BLUE	Door Lock Output
C-3	GREEN/BLACK	Door Unlock Switch Side
A-14	GREEN	Door Unlock Output
A-24	BLUE/GREEN	Trunk Release Output

MAKE THIS CONNECTION FIRST!

CHASSIS GROUND POINT
IN DRIVERS KICK PANEL

Door Lock (+)
(PINK/YELLOW)

CUT

DRIVER DOOR
JAMB BOOT
HARNESS

Door Unlock (+)
(PINK/GREEN)

CUT

IMPORTANT!

The relay wire colors shown here, are the colors used on the FORD accessory relay kits listed above. Wire colors on other relays may be different!

Half of harness that
goes back into the
vehicle interior.

Relays shown are not supplied in kit.
Relays are available by ordering Ford part number YL3Z-19G390-AA (Single) or YL3Z-19G390-BA (10 pack).

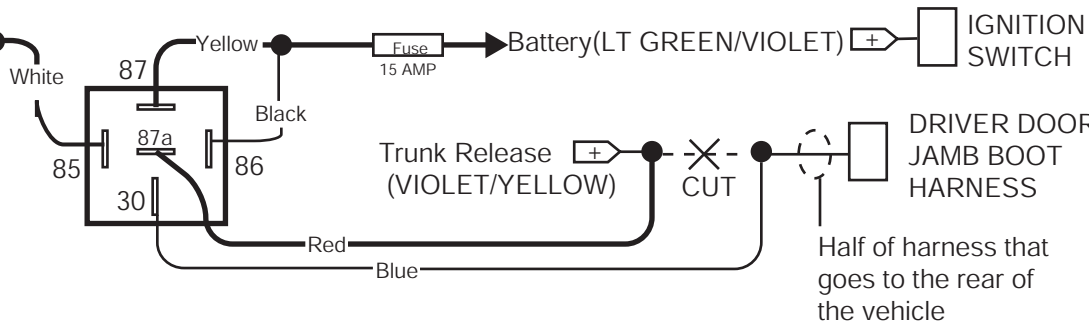

Half of harness that
goes to the rear of
the vehicle

CONNECTIONS UNDER HOOD

	Color	Function
A-19	GRAY	Hood Open Switch Input

Vehicle Interior

Engine Compartment

HOOD TILT SWITCH

Chassis Ground

Do Not Ground to Hood!

Vehicle (Year/Make/Model) '07 Crown Vic/Grand Marquis	
Equipment or Trim level ALL	System(s) applicable to: RKE/VSS/RMST
Page 5 of 6	Revision Date 6/8/06

OPTIONAL CONNECTIONS / FEATURES

OPTION PROGRAMMING REQUIREMENTS

BANK	OPTION	DESCRIPTION	LED
2	8	DRIVER UNLOCK RELAY	ON
3	1	DRIVER PRIORITY UNLOCK	ON

DRIVER'S DOOR PRIORITY UNLOCK

	Color	Function
C-9	TAN/RED	Driver Door Unlock Switch
A-13	TAN	Driver Door Unlock Motor
A-9	BROWN	Disarm Input

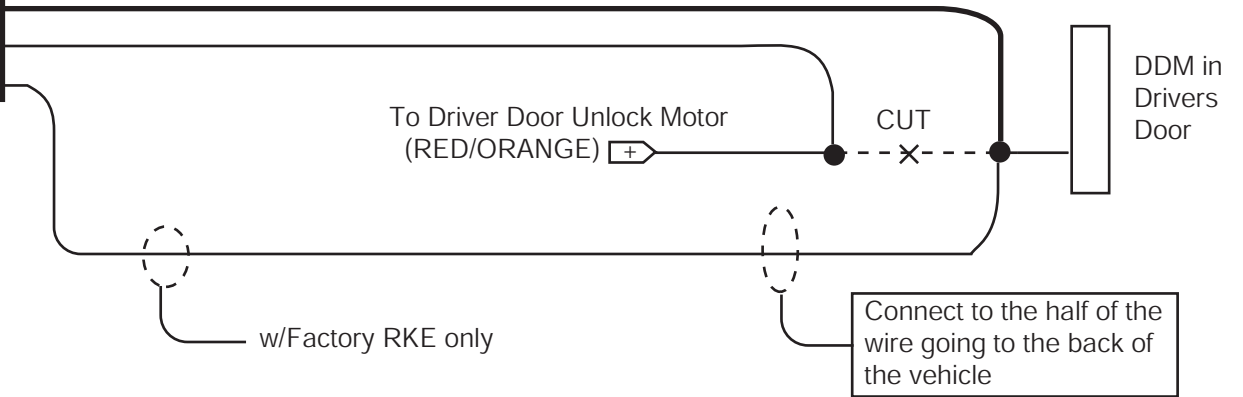

HEADLIGHTS/REAR DEFROSTER

	Color	Function
C-10	RED/WHITE	Headlight Output
C-11	BLUE/WHITE	Rear Defroster Output



Vehicle (Year/Make/Model) '07 Crown Vic/Grand Marquis	
Equipment or Trim level ALL	System(s) applicable to: RKE/VSS/RMST
Page 6 of 6	Revision Date 6/8/06

POWER WINDOW / MOONROOF INTERRUPTS

NOTE: CUTTING THIS WIRE WILL DISABLE ALL POWER WINDOWS AND MOONROOF

POWER WINDOW INTERRUPT

	Color	Function
B-10	BLUE/BLACK	Active Output

Relays shown are not supplied in kit. Relays are available by ordering Ford part number YL3Z-19G390-AA (Single) or YL3Z-19G390-BA (10 pack).

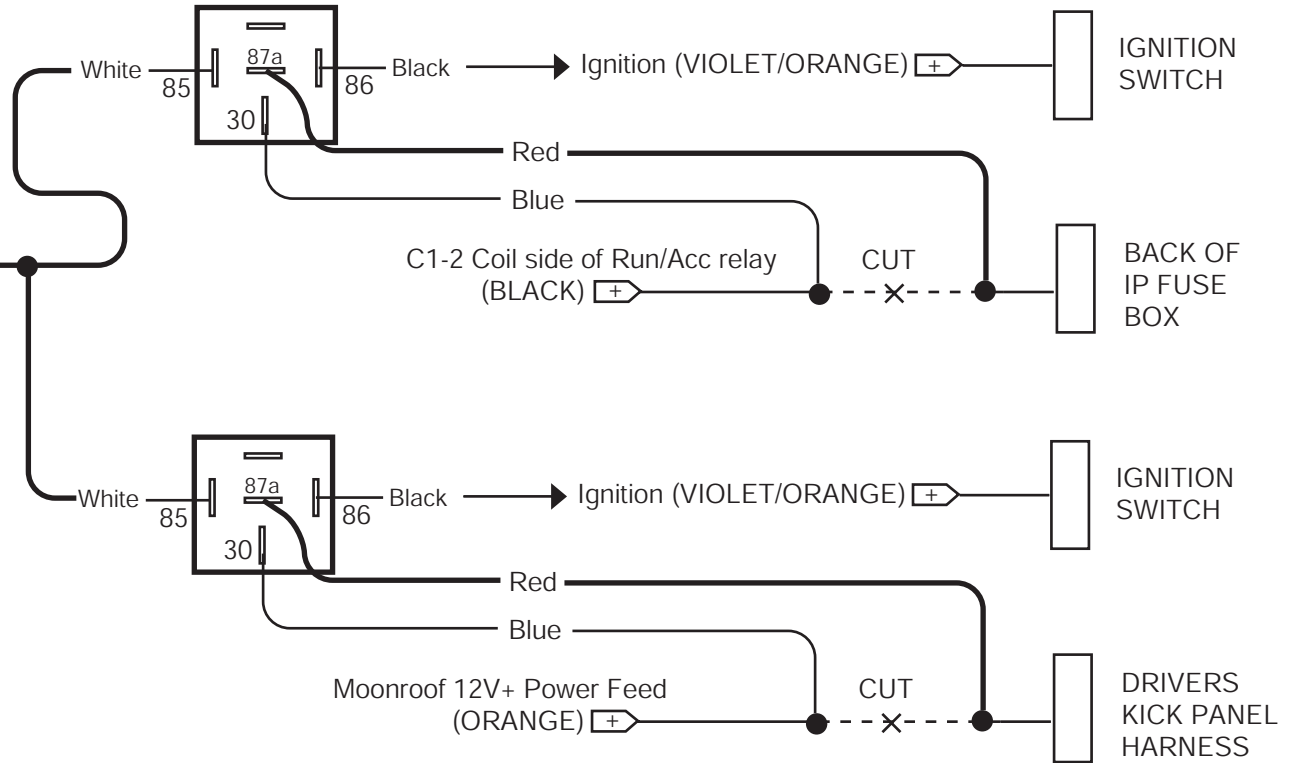

CAUTION: REMOVE YELLOW WIRE AND TERMINAL FROM RELAY SOCKET

Vehicle (Year/Make/Model) '07 Crown Vic/Grand Marquis	
Equipment or Trim level ALL	System(s) applicable to: RMST
Page 1 of 3	Revision Date 8/18/06

Module:
PC-34
7L3Z-19G367-AA

FUSE PLACEMENT CHART

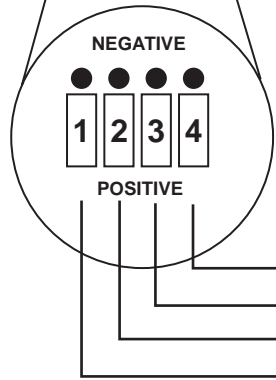
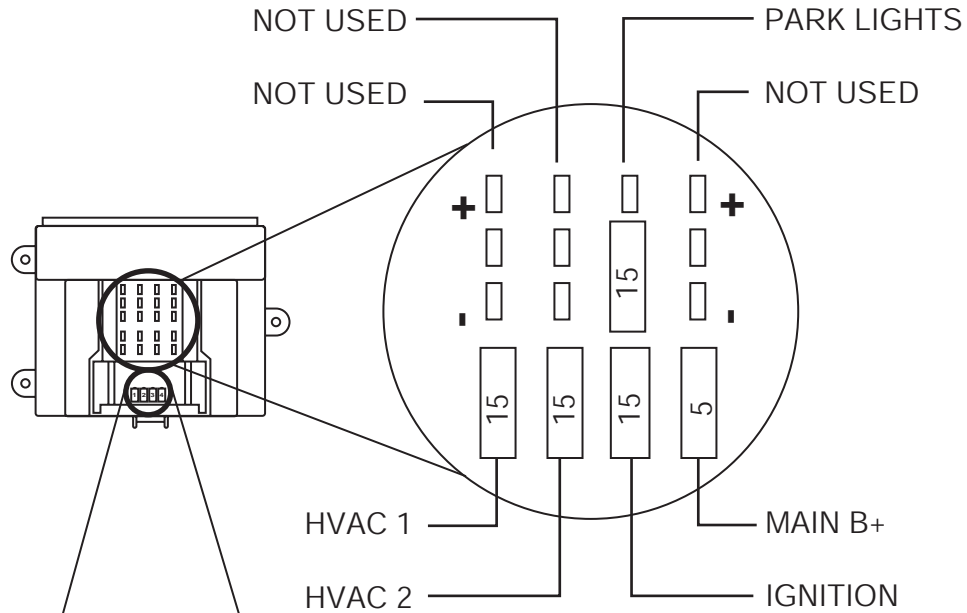

POLARITY JUMPER SETTINGS*

- N/A (DO NOT REMOVE)
- KEY-IN SENSE
- N/A (DO NOT REMOVE)
- DOOR TRIGGER

* See Polarity Jumper Section in Base Instructions for details

PARTS REQUIRED:

RMST Kit:
7W3Z-19G364-AA

Securilock (PATS) Interface:
PIK-4 (P/N: 7L2Z-19G365-AA)

RELAY REQUIREMENTS (P/N YL3Z-19G390-AA):
2- Power Window, Moonroof Interrupt Circuit
1- Trunk Release or Drivers Door Unlock (optional)

FUNCTIONAL PROGRAMMING REQUIREMENTS

BANK	OPTION	DESCRIPTION	LED
1	2	DOOR AJAR INVERT	ON
1	3	KEY-IN SENSE INVERT	ON
2	1	TACHLESS MODE	ON

MODULE MOUNTING LOCATION:

Left Side of Driver's Underdash

Vehicle (Year/Make/Model) '07 Crown Vic/Grand Marquis	
Equipment or Trim level ALL	System(s) applicable to: RMST
Page 2 of 3	Revision Date 6/8/06

USE TYPE "C" CUSTOM WIRE HARNESS

VEHICLE HARNESS

IGNITION SWITCH

STEERING COLUMN HARNESS

	Color	Function
A-7	PINK	Ignition Input/Output
B-3	PINK/WHITE	Ignition 2 Output
B-4	ORANGE	HVAC 1 Output
B-5	ORANGE/WHITE	HVAC 2 Output
A-6	VIOLET	Starter Interrupt (Key Side)
A-8	VIOLET	Starter Interrupt (Motor Side)
A-4	RED	Battery
B-2	RED	Battery
B-1	BLUE	Battery
B-8	BLACK/WHITE	Key-In Sense Input

	Color	Function
A-21	BROWN/BLACK	Horn Relay Output
A-1	WHITE	Parking Light Output

DRIVER'S KICK PANEL HARNESS

	Color	Function
A-5	BLACK	Ground
A-24	BLUE	Door Lock Output
B-7	BROWN	Brake Input
A-20	GREEN/VIOLET	Door Ajar Switch Input

UNDER HOOD HARNESS

	Color	Function
A-19	GRAY	Hood Open Switch Input

Vehicle Interior

Engine Compartment

Chassis Ground

Do Not Ground to Hood!

Hood Tilt Switch

Horn (DK. BLUE)

Parking Lights (WHITE/BLACK)

MAKE THIS CONNECTION FIRST!

CHASSIS GROUND POINT
IN DRIVER'S KICK PANEL

Door Lock (PINK/YELLOW)

Brake (LT. GREEN/RED)

Dome Light (BLACK/LT. BLUE)

STEERING COLUMN HARNESS

HEADLIGHT SWITCH

HARNESS ABOVE GAS PEDAL

BRAKE SWITCH

UNDERDASH LIGHT

Vehicle (Year/Make/Model) '07 Crown Vic/Grand Marquis	
Equipment or Trim level ALL	System(s) applicable to: RMST
Page 3 of 3	Revision Date 6/8/06

POWER WINDOW / MOONROOF INTERRUPTS

NOTE: CUTTING THIS WIRE WILL DISABLE ALL POWER WINDOWS AND MOONROOF

POWER WINDOW INTERRUPT

	Color	Function
B-10	BLUE/BLACK	Active Output

Relays shown are not supplied in kit. Relays are available by ordering Ford part number YL3Z-19G390-AA (Single) or YL3Z-19G390-BA (10 pack).

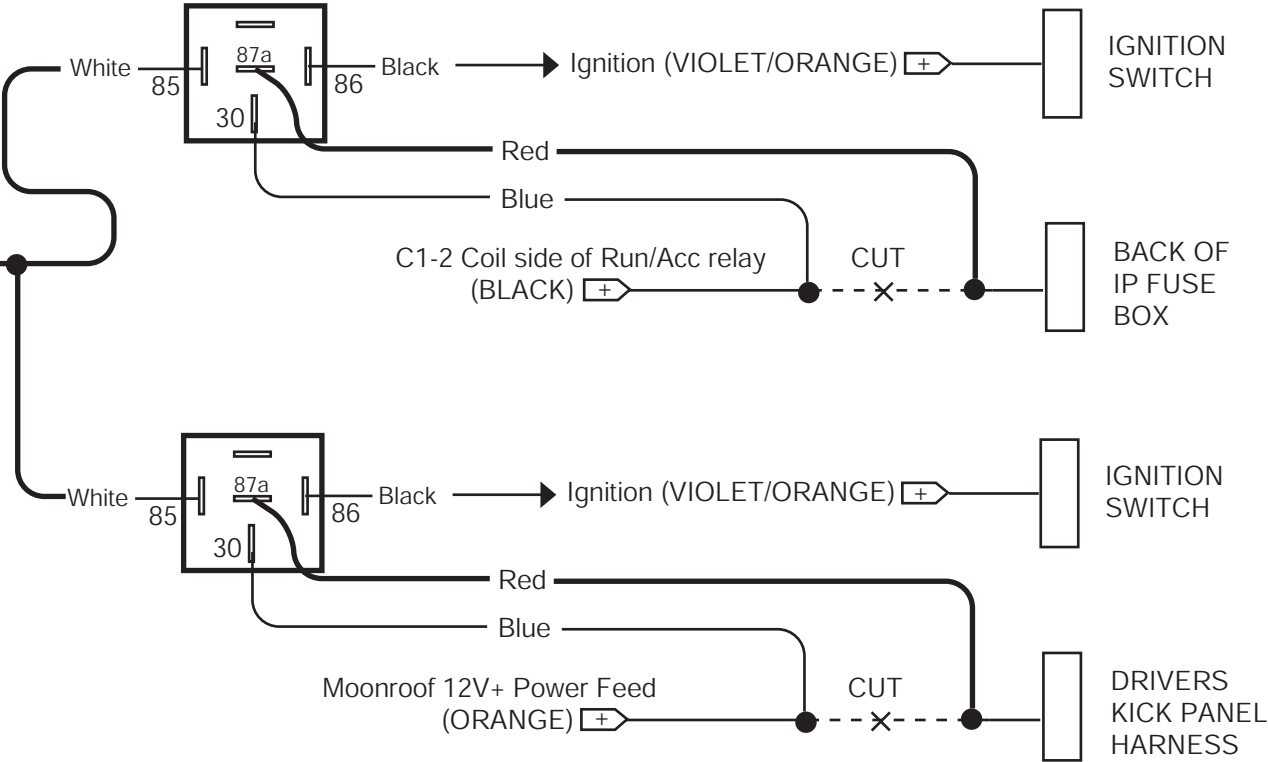

CAUTION: REMOVE YELLOW WIRE AND TERMINAL FROM RELAY SOCKET

Vehicle (Year/Make/Model) '07 Crown Vic/Grand Marquis	
Equipment or Trim level ALL	System(s) applicable to: VSS
Page 1 of 2	Revision Date 6/8/06

Module:
PC-14
7L2Z-19G367-AA

FUSE PLACEMENT CHART

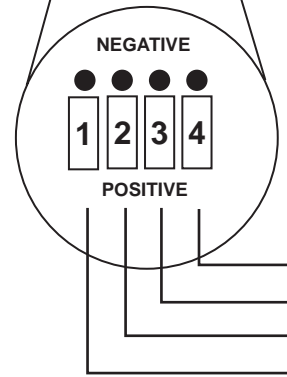
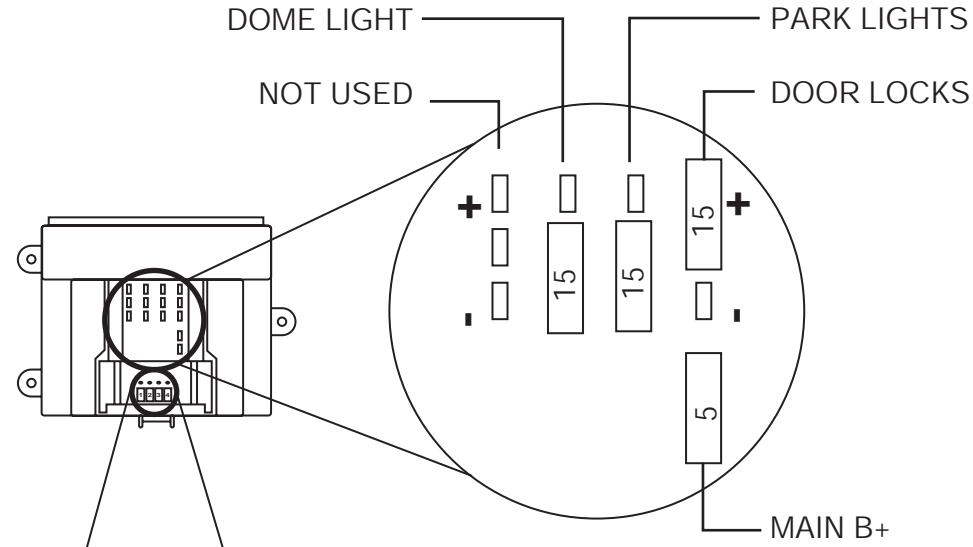

POLARITY JUMPER SETTINGS*

- N/A (DO NOT REMOVE)
- N/A (DO NOT REMOVE)
- UNLOCK SENSE
- DOOR TRIGGER

* See Polarity Jumper Section in Base Instructions for details

PARTS REQUIRED:

VSS Kit:
7L3Z-19A361-AA

FUNCTIONAL PROGRAMMING REQUIREMENTS

BANK	OPTION	DESCRIPTION	LED
1	1	LITE TOUCH ADJUSTMENT	note 1
1	2	FULL SHOCK ADJUSTMENT	note 1
1	4	DOOR AJAR INVERT	ON
1	5	UNLOCK SENSE INVERT	ON
2	1	STARTER INTERRUPT	ON

Note 1: Perform proper adjustments per the "Shock Sensor Setting" section of the Base instruction sheets.

MODULE MOUNTING LOCATION:

Left Side of Driver's Underdash

NOTE:

IF USING THIS SYSTEM IN LOT MODE, WIRE HARNESS P/N 2W7Z-19C757-BA WILL HAVE TO BE ORDERED TO ACCESS THE 'FACTORY DISARM OUTPUT" WIRE (LT.GREEN/BLACK).

Vehicle (Year/Make/Model)	
'07 Crown Vic/Grand Marquis	
Equipment or Trim level	System(s) applicable to:
w/Factory RKE	VSS
Page	Revision Date
2 of 2	6/8/06

STEERING COLUMN HARNESS

	Color	Function
A-4	RED	Battery
A-7	PINK	Ignition Input
A-8	VIOLET	Starter Interrupt (Motor side)
A-6	VIOLET/RED	Starter Interrupt (Key side)
A-21	BROWN/BLACK	Horn Relay Output
A-1	WHITE	Parking Light Output
A-20	GREEN/VIOLET	Door Ajar Switch Input

MAKE THIS CONNECTION LAST!

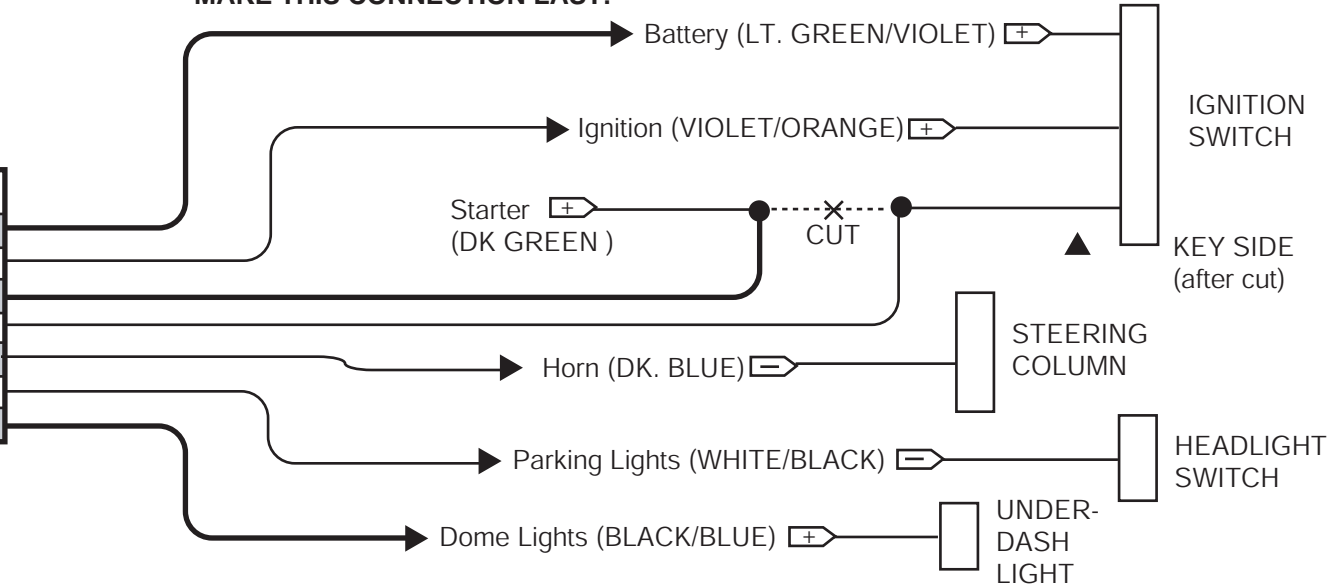

DRIVER'S KICK PANEL HARNESS

	Color	Function
A-5	BLACK	Ground
A-2	BLUE	Door Lock Output
A-14	GREEN	Door Unlock Output
A-11	WHITE/BLUE	Arm Input
A-9	BROWN	Disarm Input
A-12	WHITE/BLUE	Unlock Switch Sense

MAKE THIS CONNECTION FIRST!

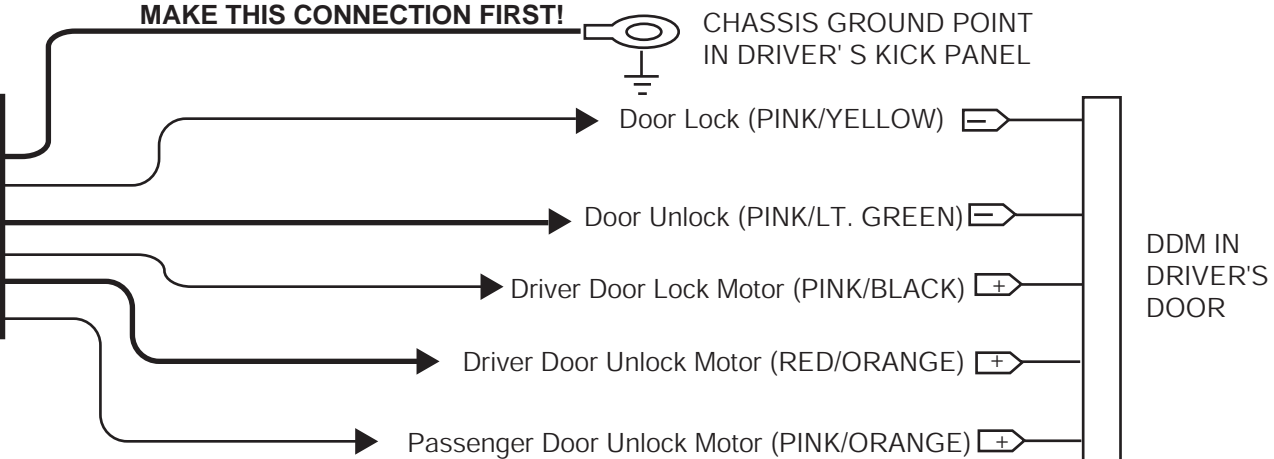

	Color	Function
C-4	LT.GREEN/BLACK	Factory Alarm Disarm Output



Vehicle (Year/Make/Model) '08 Crown Vic/Grand Marquis	
Equipment or Trim level ALL	System(s) applicable to: RKE/VSS/RMST
Page 1 of 6	Revision Date 4/13/07

Module:
PC-34
7L3Z-19G367-AA

FUSE PLACEMENT CHART

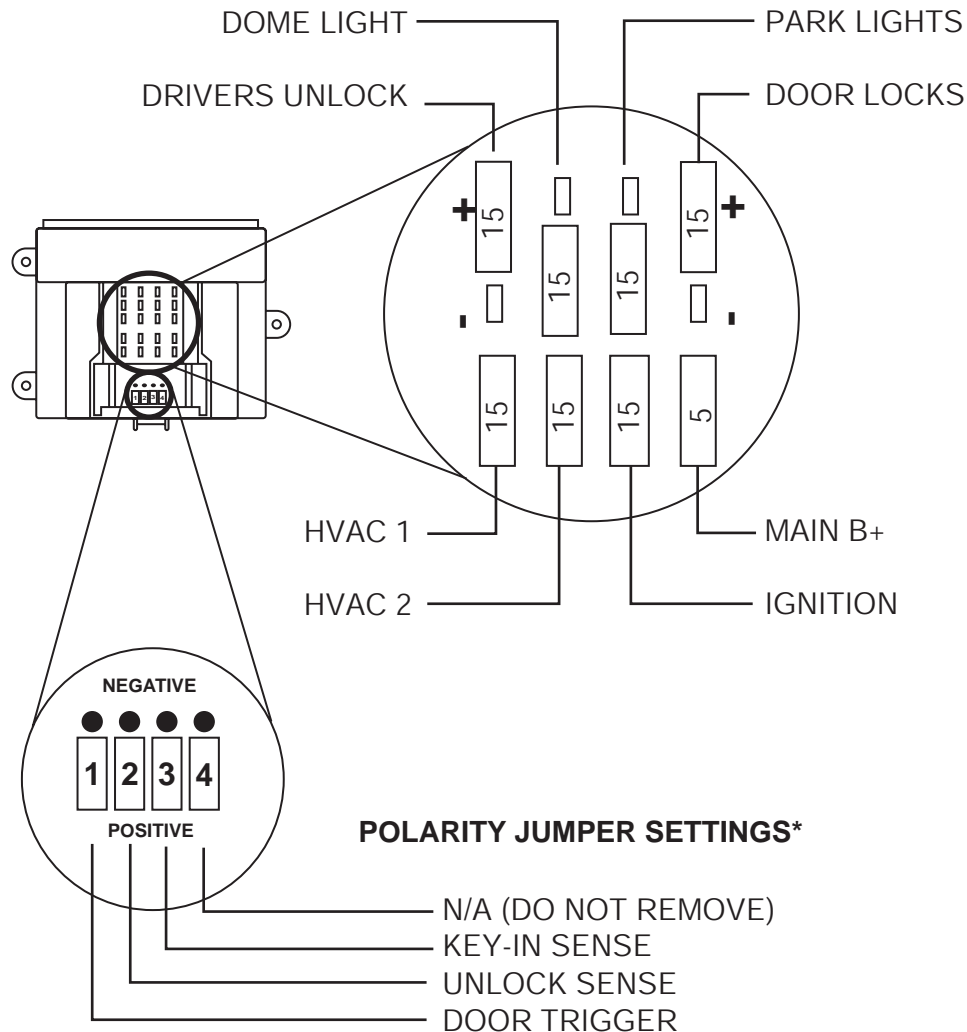

POLARITY JUMPER SETTINGS*

* See Polarity Jumper Section in Base Instructions for details

PARTS REQUIRED:

RKE/VSS/RMST Kit:
7L3Z-19G364-AA

Securilock (PATS) Interface:
PIK-4 (P/N: 7L2Z-19G365-AA - order separately)

RELAY REQUIREMENTS (P/N YL3Z-19G390-AA):
2- Power Window, Moonroof Interrupt Circuit
1- Trunk Release or Drivers Door Unlock (optional)

FUNCTIONAL PROGRAMMING REQUIREMENTS

BANK	OPTION	DESCRIPTION	LED
1	1	LITE TOUCH ADJUSTMENT	note 1
1	2	FULL SHOCK ADJUSTMENT	note 1
1	4	DOOR AJAR INVERT	ON
1	5	UNLOCK SENSE INVERT	ON
1	6	KEY-IN SENSE INVERT	ON
2	1	STARTER INTERRUPT	OFF
2	8	DRIVER UNLOCK RELAY	note 2
3	1	DRIVER PRIORITY UNLOCK	note 2
4	1	TACHLESS MODE	ON

Note 1: Perform proper adjustments per the "Shock Sensor Setting" section of the Base instruction sheets.

Note 2: See the Optional Connections / Features page

MODULE MOUNTING LOCATION:
Left Side of Driver's Underdash

Vehicle (Year/Make/Model)	
'08 Crown Vic/Grand Marquis	
Equipment or Trim level	System(s) applicable to:
ALL	RKE/VSS/RMST
Page	Revision Date
2 of 6	4/13/07

STEERING COLUMN HARNESS

	Color	Function
A-4	RED	Battery
B-1	BLUE	HVAC2 Feed
B-2	RED	HVAC 1 12 volt Battery Feed
A-7	PINK	Ignition 1 Input/Output
B-4	ORANGE	HVAC 1 Output
B-5	ORANGE/WHITE	HVAC 2 Output
A-8	VIOLET	Starter Output
B-8	BLACK/WHITE	Key-in-sense Input
A-21	BROWN/BLACK	Horn Relay Output
A-1	WHITE	Parking Light Output
A-3	BLACK/WHITE	Dome Light Output
A-20	GREEN/VIOLET	Door Ajar Switch Input
B-7	BROWN	Brake Input
C-10	RED/WHITE	Headlight Output
C-11	BLUE/WHITE	Rear Defroster Output

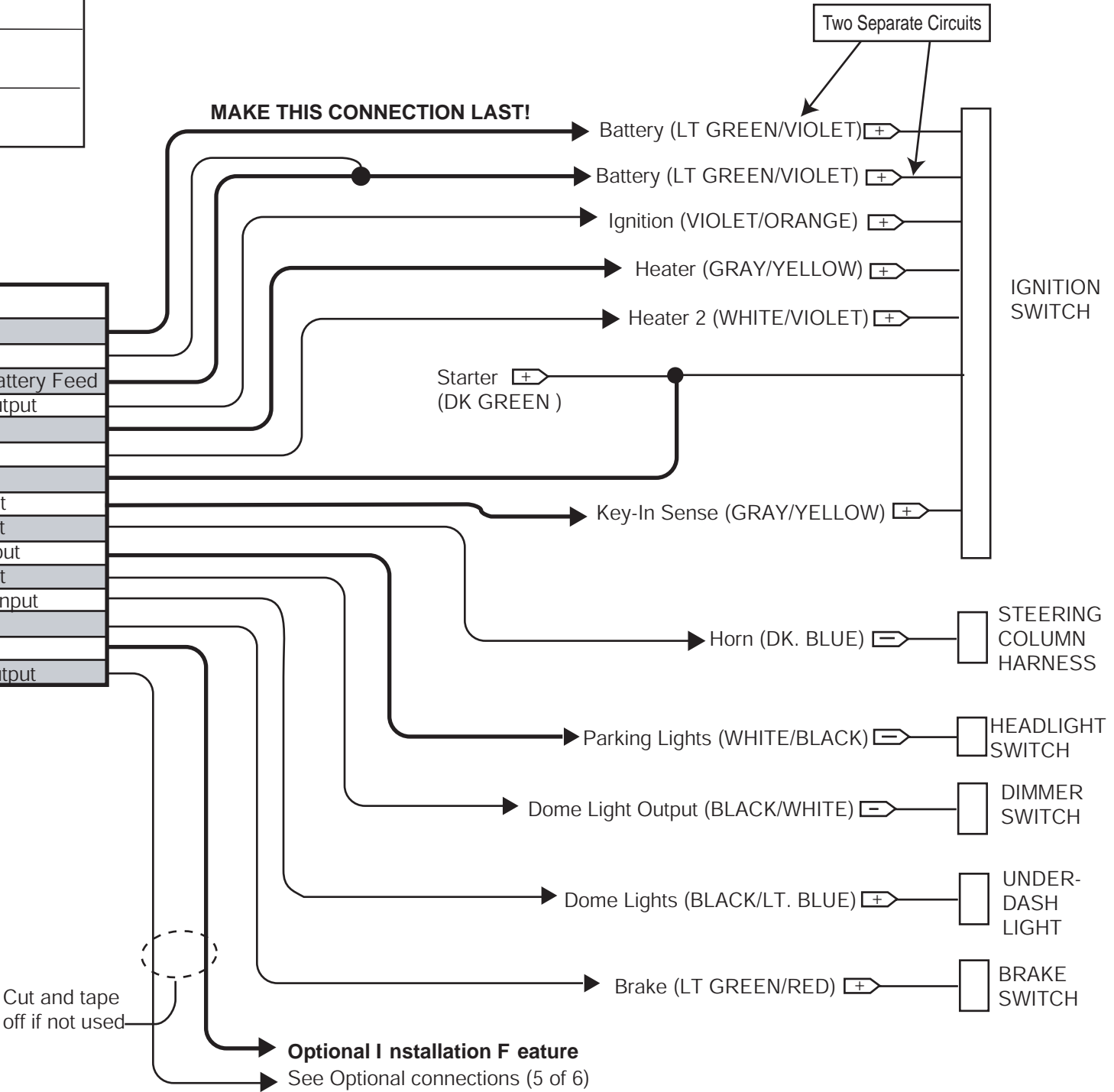

Vehicle (Year/Make/Model)	
'08 Crown Vic/Grand Marquis	
Equipment or Trim level	System(s) applicable to:
W/Factory RKE	RKE/VSS/RMST
Page	Revision Date
3 of 6	4/13/07

DRIVER'S KICK PANEL HARNESS

	Color	Function
A-5	BLACK	Ground
A-9	BROWN	Disarm Input
A-11	WHITE/BLUE	Arm Input
A-12	LT GREEN	Unlock Switch Sense
A-14	GREEN	Door Unlock Output
A-2	BLUE	Door Lock Output
A-24	BLUE/GREEN	Trunk Release Output
C-4	LT GREEN/BLACK	Factory Alarm Disarm Output

MAKE THIS CONNECTION FIRST!

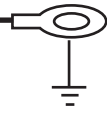

CHASSIS GROUND POINT
IN DRIVER'S KICK PANEL

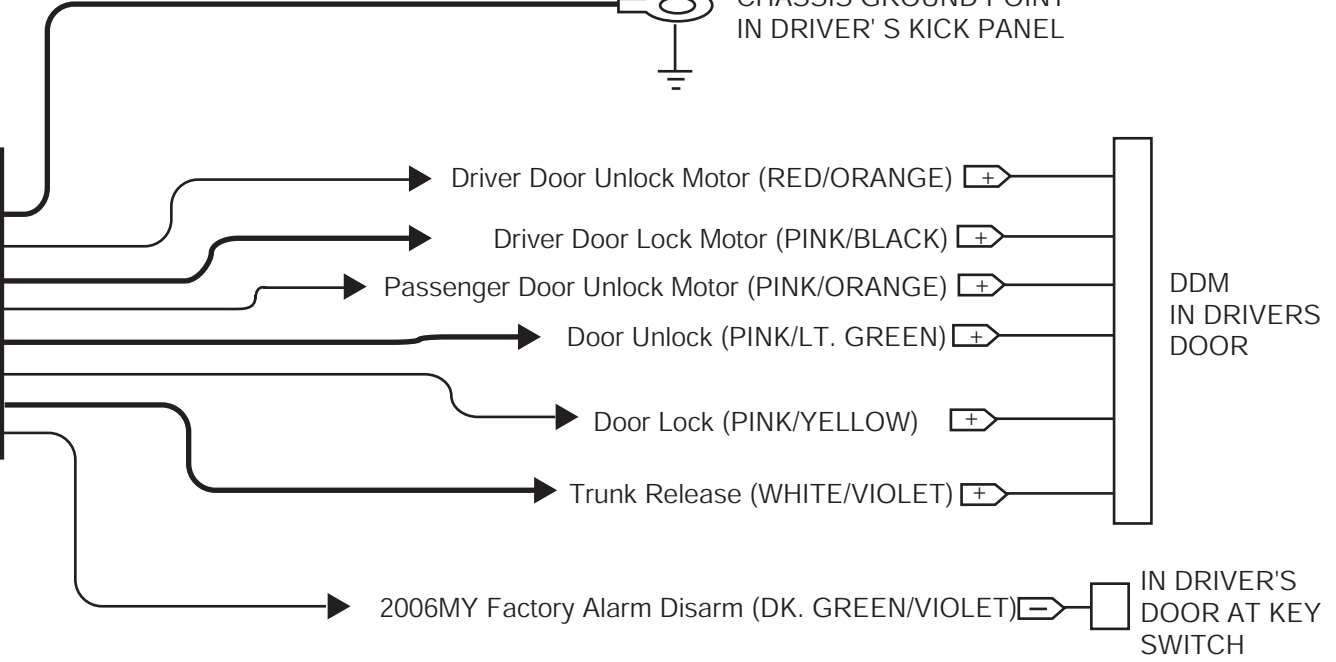

CONNECTIONS UNDER HOOD

	Color	Function
A-19	GRAY	Hood Open Switch Input

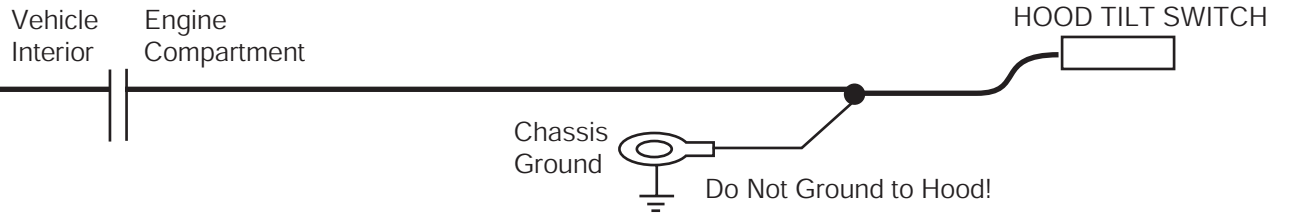

Vehicle (Year/Make/Model)	
'08 Crown Vic/Grand Marquis	
Equipment or Trim level w/o Factory RKE	System(s) applicable to: RKE/VSS/RMST
Page 4 of 6	Revision Date 4/13/07

DRIVERS SIDE KICK PANEL HARNESS

	Color	Function
A-5	BLACK	Ground
C-1	BLUE/BLACK	Door Lock Switch Side
A-2	BLUE	Door Lock Output
C-3	GREEN/BLACK	Door Unlock Switch Side
A-14	GREEN	Door Unlock Output
A-24	BLUE/GREEN	Trunk Release Output

MAKE THIS CONNECTION FIRST!

CHASSIS GROUND POINT
IN DRIVERS KICK PANEL

Door Lock (+)
(PINK/YELLOW)



CUT

Door Unlock (+)
(PINK/LT. GREEN)



CUT

DRIVER DOOR
JAMB BOOT
HARNESS

IMPORTANT!

The relay wire colors shown here, are the colors used on the FORD accessory relay kits listed above. Wire colors on other relays may be different!

Half of harness that
goes back into the
vehicle interior.

Relays shown are not supplied in kit.
Relays are available by ordering Ford part
number YL3Z-19G390-AA (Single) or YL3Z-
19G390-BA (10 pack).

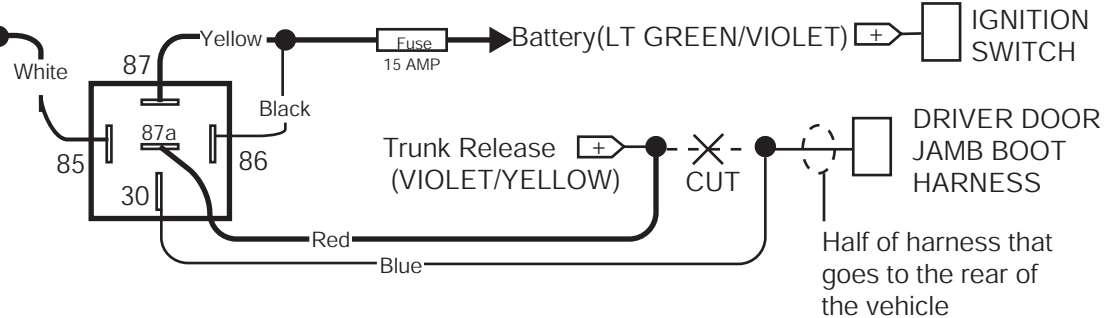

CONNECTIONS UNDER HOOD

	Color	Function
A-19	GRAY	Hood Open Switch Input

Vehicle
Interior

Engine
Compartment

HOOD TILT SWITCH

Chassis
Ground



Do Not Ground to Hood!

Vehicle (Year/Make/Model) '08 Crown Vic/Grand Marquis	
Equipment or Trim level ALL	System(s) applicable to: RKE/VSS/RMST
Page 5 of 6	Revision Date 4/13/07

OPTIONAL CONNECTIONS / FEATURES

OPTION PROGRAMMING REQUIREMENTS

BANK	OPTION	DESCRIPTION	LED
2	8	DRIVER UNLOCK RELAY	ON
3	1	DRIVER PRIORITY UNLOCK	ON

DRIVER'S DOOR PRIORITY UNLOCK

	Color	Function
C-9	TAN/RED	Driver Door Unlock Switch
A-13	TAN	Driver Door Unlock Motor
A-9	BROWN	Disarm Input

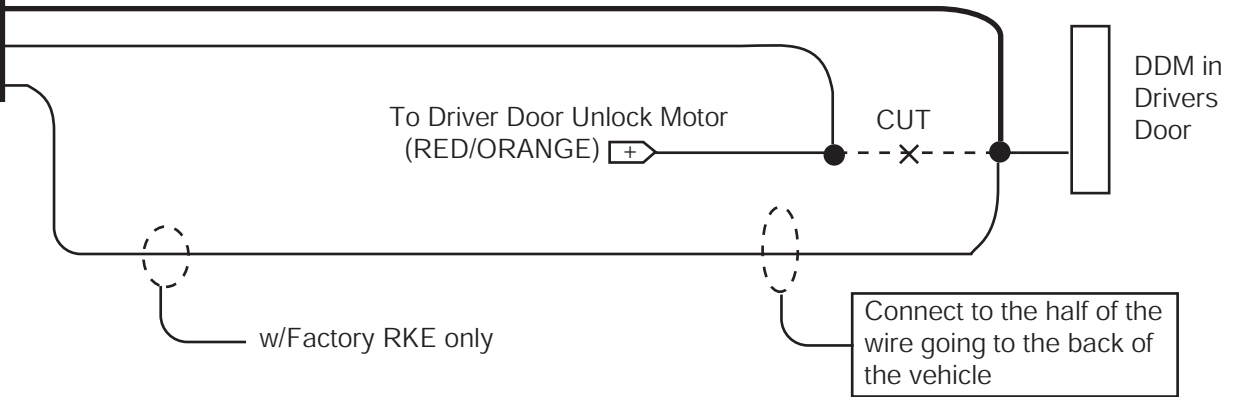

HEADLIGHTS/REAR DEFROSTER

	Color	Function
C-10	RED/WHITE	Headlight Output
C-11	BLUE/WHITE	Rear Defroster Output



Vehicle (Year/Make/Model)	
'08 Crown Vic/Grand Marquis	
Equipment or Trim level	System(s) applicable to:
ALL	RKE/VSS/RMST
Page	Revision Date
6 of 6	4/13/07

POWER WINDOW / MOONROOF INTERRUPTS

NOTE: CUTTING THIS WIRE WILL DISABLE ALL POWER WINDOWS AND MOONROOF

POWER WINDOW INTERRUPT

	Color	Function
B-10	BLUE/BLACK	Active Output

Relays shown are not supplied in kit. Relays are available by ordering Ford part number YL3Z-19G390-AA (Single) or YL3Z-19G390-BA (10 pack).

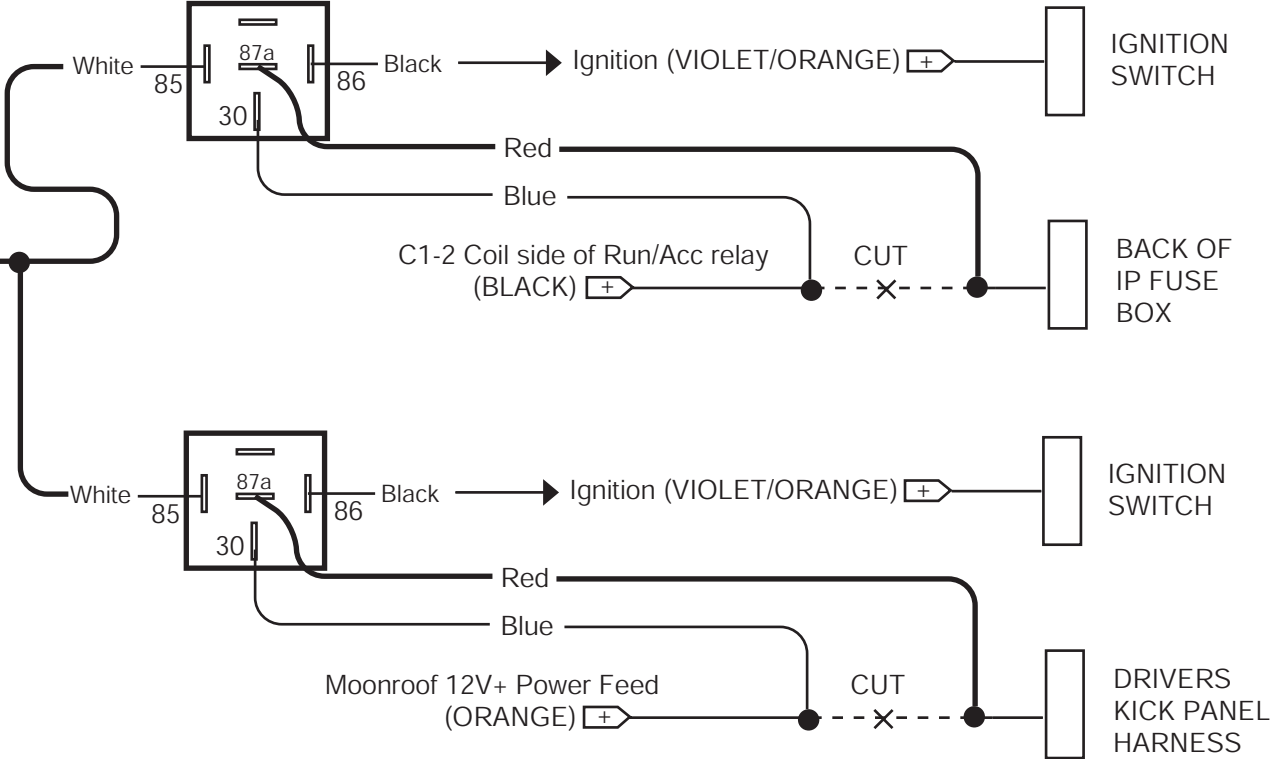

CAUTION: REMOVE YELLOW WIRE AND TERMINAL FROM RELAY SOCKET

Vehicle (Year/Make/Model) '08 Crown Vic/Grand Marquis	
Equipment or Trim level ALL	System(s) applicable to: RMST
Page 1 of 3	Revision Date 4/13/07

Module:
PC-34
7L3Z-19G367-AA

FUSE PLACEMENT CHART

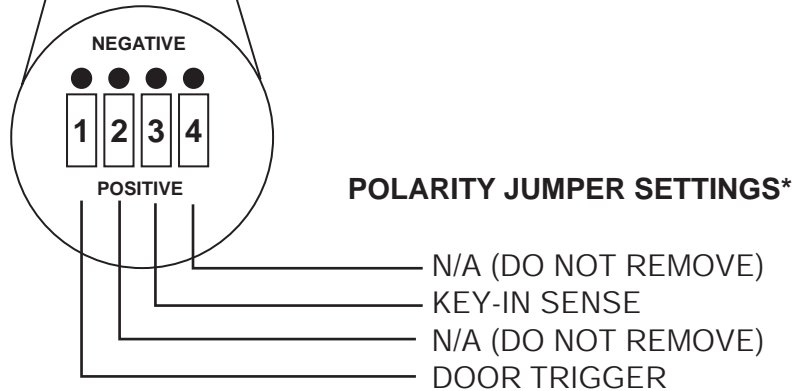
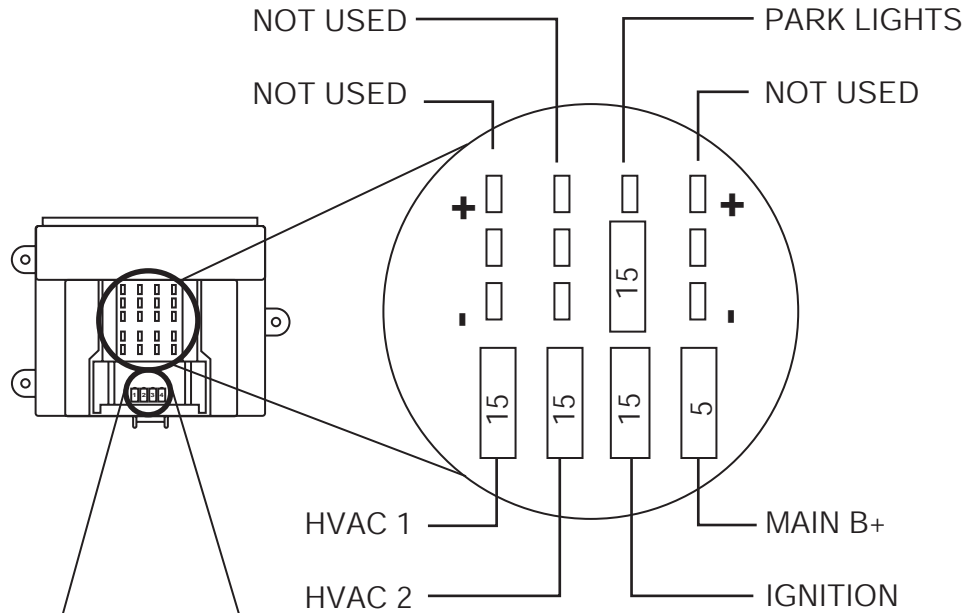

POLARITY JUMPER SETTINGS*

* See Polarity Jumper Section in Base Instructions for details

PARTS REQUIRED:

RMST Kit:
7W3Z-19G364-AA

Securilock (PATS) Interface:
PIK-4 (P/N: 7L2Z-19G365-AA)

RELAY REQUIREMENTS (P/N YL3Z-19G390-AA):
2- Power Window, Moonroof Interrupt Circuit
1- Trunk Release or Drivers Door Unlock (optional)

FUNCTIONAL PROGRAMMING REQUIREMENTS

BANK	OPTION	DESCRIPTION	LED
1	2	DOOR AJAR INVERT	ON
1	3	KEY-IN SENSE INVERT	ON
2	1	TACHLESS MODE	ON

MODULE MOUNTING LOCATION:

Left Side of Driver's Underdash

Vehicle (Year/Make/Model)	
'07 Crown Vic/Grand Marquis	
Equipment or Trim level	System(s) applicable to:
ALL	RMST
Page	Revision Date
2 of 3	6/8/06

USE TYPE "C" CUSTOM WIRE HARNESS

VEHICLE HARNESS

IGNITION SWITCH

STEERING COLUMN HARNESS

	Color	Function
A-7	PINK	Ignition Input/Output
B-3	PINK/WHITE	Ignition 2 Output
B-4	ORANGE	HVAC 1 Output
B-5	ORANGE/WHITE	HVAC 2 Output
A-6	VIOLET	Starter Interrupt (Key Side)
A-8	VIOLET	Starter Interrupt (Motor Side)
A-4	RED	Battery
B-2	RED	Battery
B-1	BLUE	Battery
B-8	BLACK/WHITE	Key-In Sense Input

	Color	Function
A-21	BROWN/BLACK	Horn Relay Output
A-1	WHITE	Parking Light Output

DRIVER'S KICK PANEL HARNESS

	Color	Function
A-5	BLACK	Ground
B-7	BROWN	Brake Input
A-20	GREEN/VIOLET	Door Ajar Switch Input
A-24	BLUE	Door Lock Output

UNDER HOOD HARNESS

	Color	Function
A-19	GRAY	Hood Open Switch Input

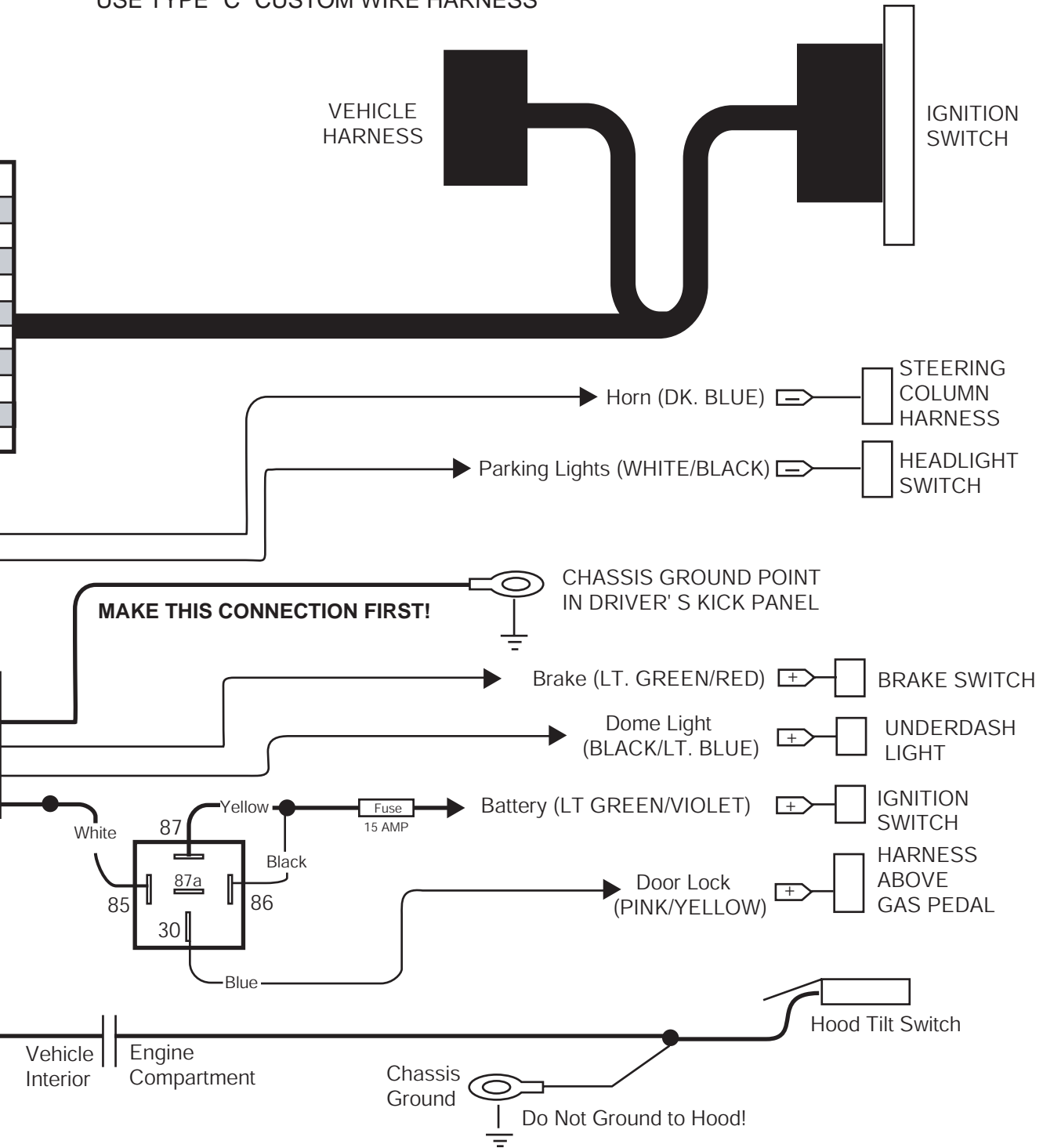

Vehicle (Year/Make/Model) '08 Crown Vic/Grand Marquis	
Equipment or Trim level ALL	System(s) applicable to: RMST
Page 3 of 3	Revision Date 4/13/07

POWER WINDOW / MOONROOF INTERRUPTS

NOTE: CUTTING THIS WIRE WILL DISABLE ALL POWER WINDOWS AND MOONROOF

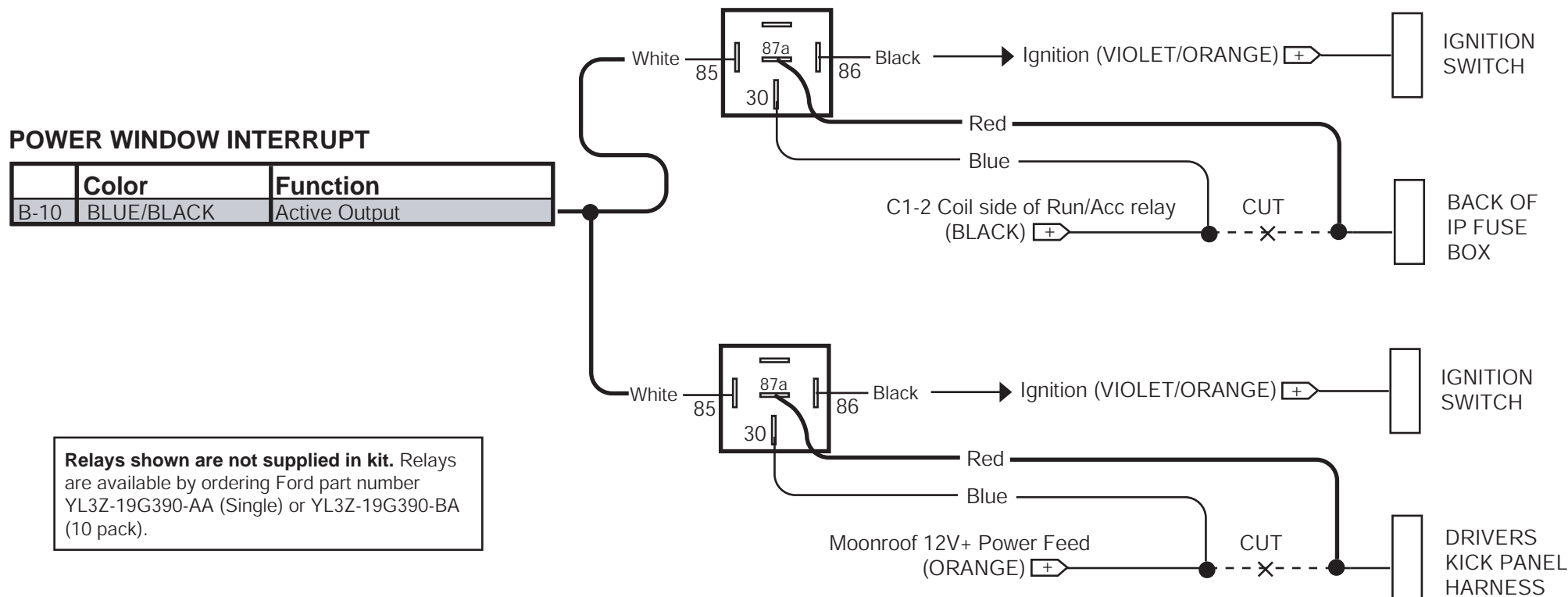

CAUTION: REMOVE YELLOW WIRE AND TERMINAL FROM RELAY SOCKET

Vehicle (Year/Make/Model) '08 Crown Vic/Grand Marquis	
Equipment or Trim level ALL	System(s) applicable to: VSS
Page 1 of 2	Revision Date 4/13/07

Module:
PC-14
7L2Z-19G367-AA

FUSE PLACEMENT CHART

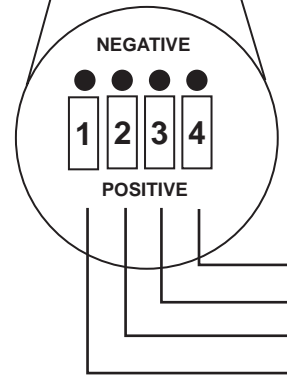
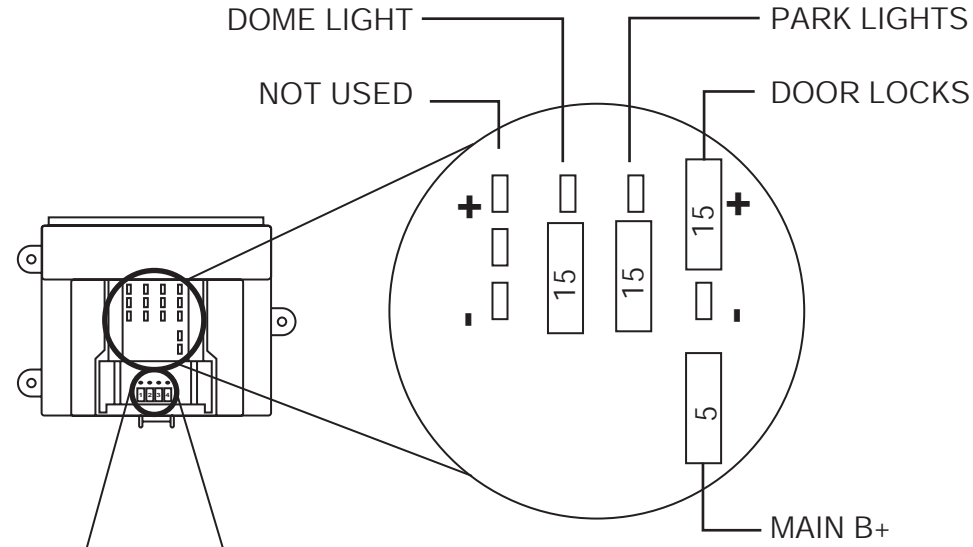

POLARITY JUMPER SETTINGS*

- N/A (DO NOT REMOVE)
- N/A (DO NOT REMOVE)
- UNLOCK SENSE
- DOOR TRIGGER

* See Polarity Jumper Section in Base Instructions for details

PARTS REQUIRED:

VSS Kit:
7L3Z-19A361-AA

FUNCTIONAL PROGRAMMING REQUIREMENTS

BANK	OPTION	DESCRIPTION	LED
1	1	LITE TOUCH ADJUSTMENT	note 1
1	2	FULL SHOCK ADJUSTMENT	note 1
1	4	DOOR AJAR INVERT	ON
1	5	UNLOCK SENSE INVERT	ON
2	1	STARTER INTERRUPT	ON

Note 1: Perform proper adjustments per the "Shock Sensor Setting" section of the Base instruction sheets.

MODULE MOUNTING LOCATION:

Left Side of Driver's Underdash

NOTE:

IF USING THIS SYSTEM IN LOT MODE, WIRE HARNESS P/N 2W7Z-19C757-BA WILL HAVE TO BE ORDERED TO ACCESS THE 'FACTORY DISARM OUTPUT" WIRE (LT.GREEN/BLACK).

Vehicle (Year/Make/Model)	
'08 Crown Vic/Grand Marquis	
Equipment or Trim level	System(s) applicable to:
w/Factory RKE	VSS
Page	Revision Date
2 of 2	4/13/07

STEERING COLUMN HARNESS

	Color	Function
A-4	RED	Battery
A-7	PINK	Ignition Input
A-8	VIOLET	Starter Interrupt (Motor side)
A-6	VIOLET/RED	Starter Interrupt (Key side)
A-21	BROWN/BLACK	Horn Relay Output
A-1	WHITE	Parking Light Output
A-20	GREEN/VIOLET	Door Ajar Switch Input

MAKE THIS CONNECTION LAST!

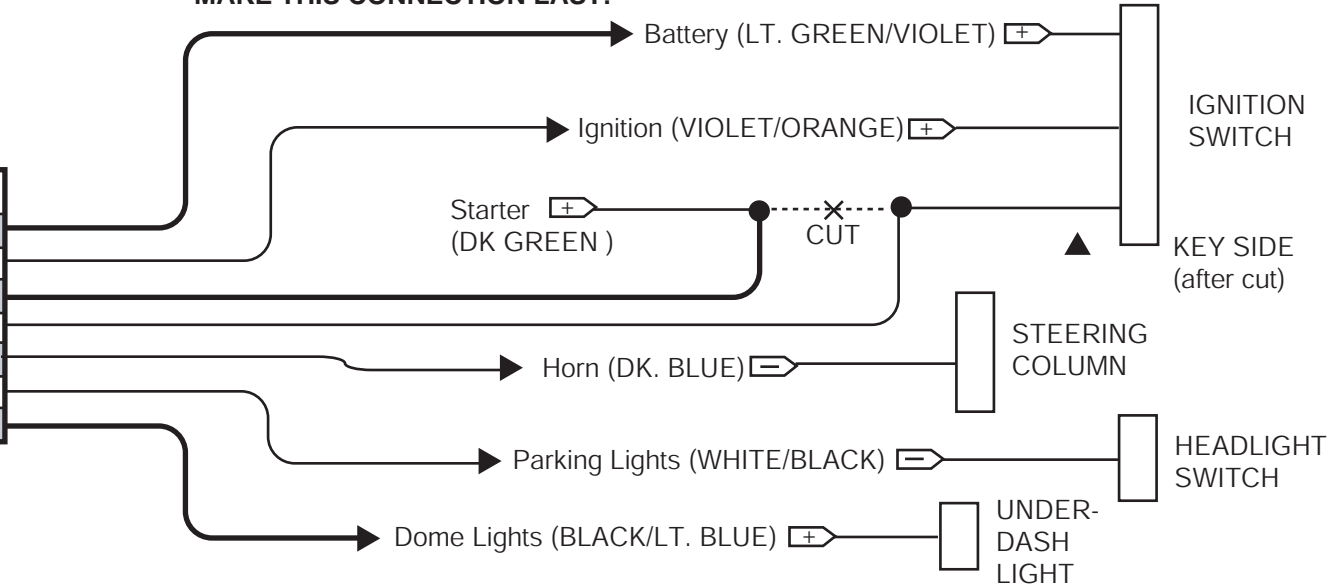

DRIVER'S KICK PANEL HARNESS

	Color	Function
A-5	BLACK	Ground
A-2	BLUE	Door Lock Output
A-14	GREEN	Door Unlock Output
A-11	WHITE/BLUE	Arm Input
A-9	BROWN	Disarm Input
A-12	WHITE/BLUE	Unlock Switch Sense

MAKE THIS CONNECTION FIRST!

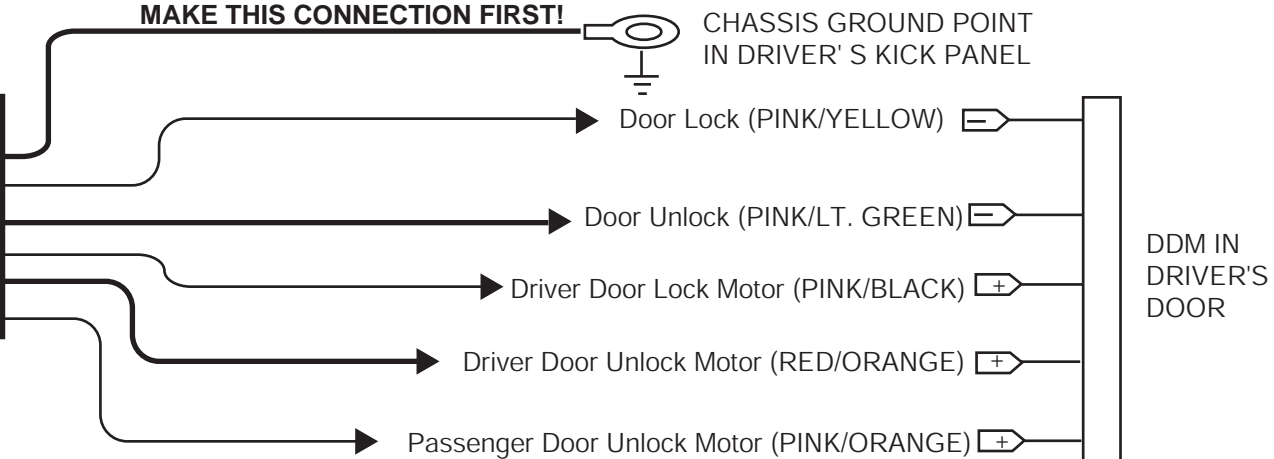

	Color	Function
C-4	LT.GREEN/BLACK	Factory Alarm Disarm Output

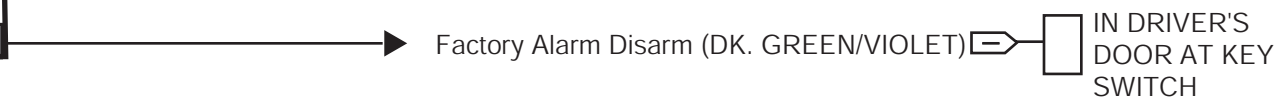

Vehicle (Year/Make/Model) '08 Mustang	
Equipment or Trim level ALL	System(s) applicable to: RKE/VSS/RMST
Page 1 of 4	Revision Date 6/4/07

Module:
PC-34
7L3Z-19G367-AA

FUSE PLACEMENT CHART

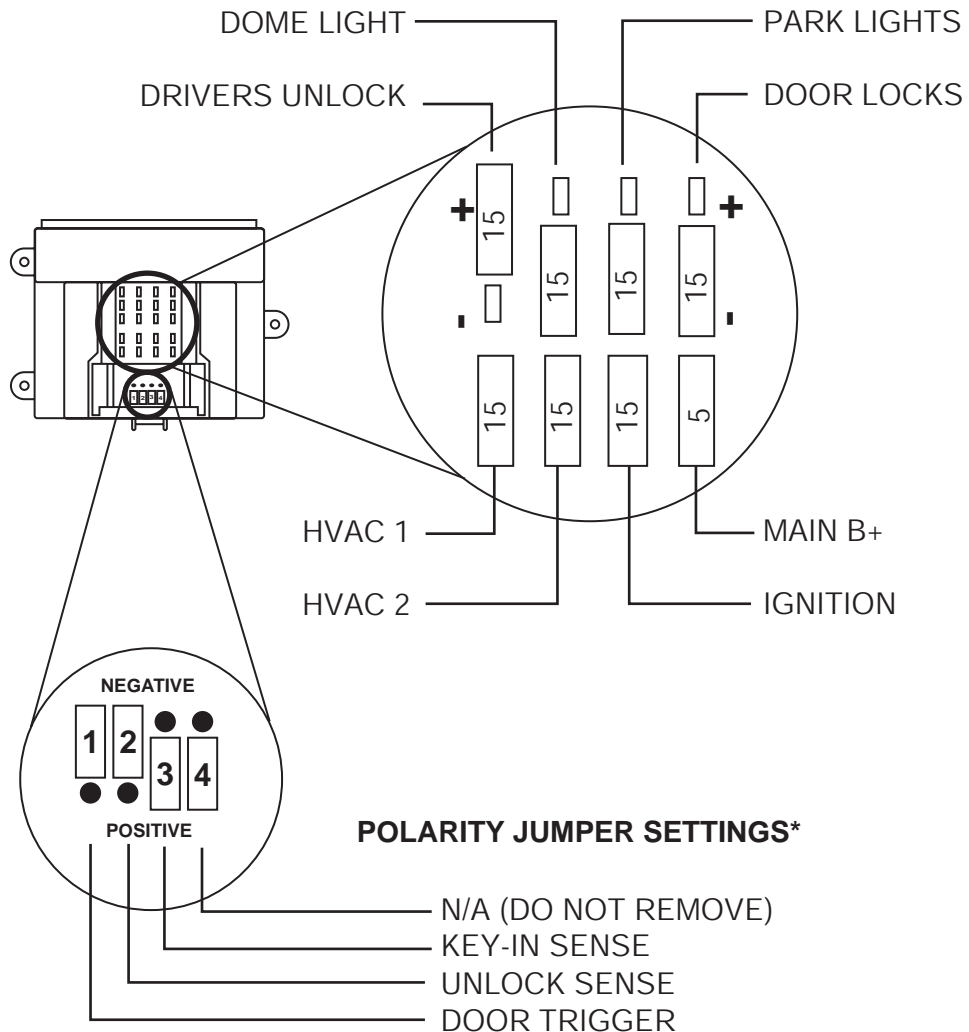

POLARITY JUMPER SETTINGS*

* See Polarity Jumper Section in Base Instructions for details

PARTS REQUIRED:

RKE/VSS/RMST Kit:
7L3Z-19G364-AA

Securilock (PATS) Interface:
PIK-4 (P/N: 7L2Z-19G365-AA - order separately)

FUNCTIONAL PROGRAMMING REQUIREMENTS

BANK	OPTION	DESCRIPTION	LED
1	1	LITE TOUCH ADJUSTMENT	note 1
1	2	FULL SHOCK ADJUSTMENT	note 1
1	4	DOOR AJAR INVERT	ON
1	5	UNLOCK SENSE INVERT	ON
1	6	KEY-IN SENSE INVERT	ON
2	1	STARTER INTERRUPT	OFF
2	8	DRIVER UNLOCK RELAY	note 2
3	1	DRIVER PRIORITY UNLOCK	note 2
4	1	TACHLESS MODE	ON

Note 1: Perform proper adjustments per the "Shock Sensor Setting" section of the Base instruction sheets.

Note 2: See the Optional Connections / Features page

MODULE MOUNTING LOCATION:

Left Side of Driver's Underdash

Vehicle (Year/Make/Model) '08 Mustang	
Equipment or Trim level ALL	System(s) applicable to: RKE/VSS/RMST
Page 2 of 4	Revision Date 6/4/07

DRIVER'S SIDE KICK PANEL HARNESS

	Color	Function
A-5	BLACK	Ground

Note: Must Connect To Avoid False Alarms

STEERING COLUMN HARNESS

	Color	Function
A-4	RED	Battery
A-20	GREEN/VIOLET	Door Trigger Input Pull-up
B-2	RED	HVAC1 Battery Feed
A-7	PINK	Ignition 1 Input/Output
B-4	ORANGE	HVAC1 Output
B-8	BLACK/WHITE	Key-in-sense Input
A-8	VIOLET	Starter Interrupt Motor Side
A-3	BLACK/WHITE	Dome Light Output
A-21	BROWN/BLACK	Horn Relay Output
A-1	WHITE	Parking Light Output
B-7	BROWN	Brake Input

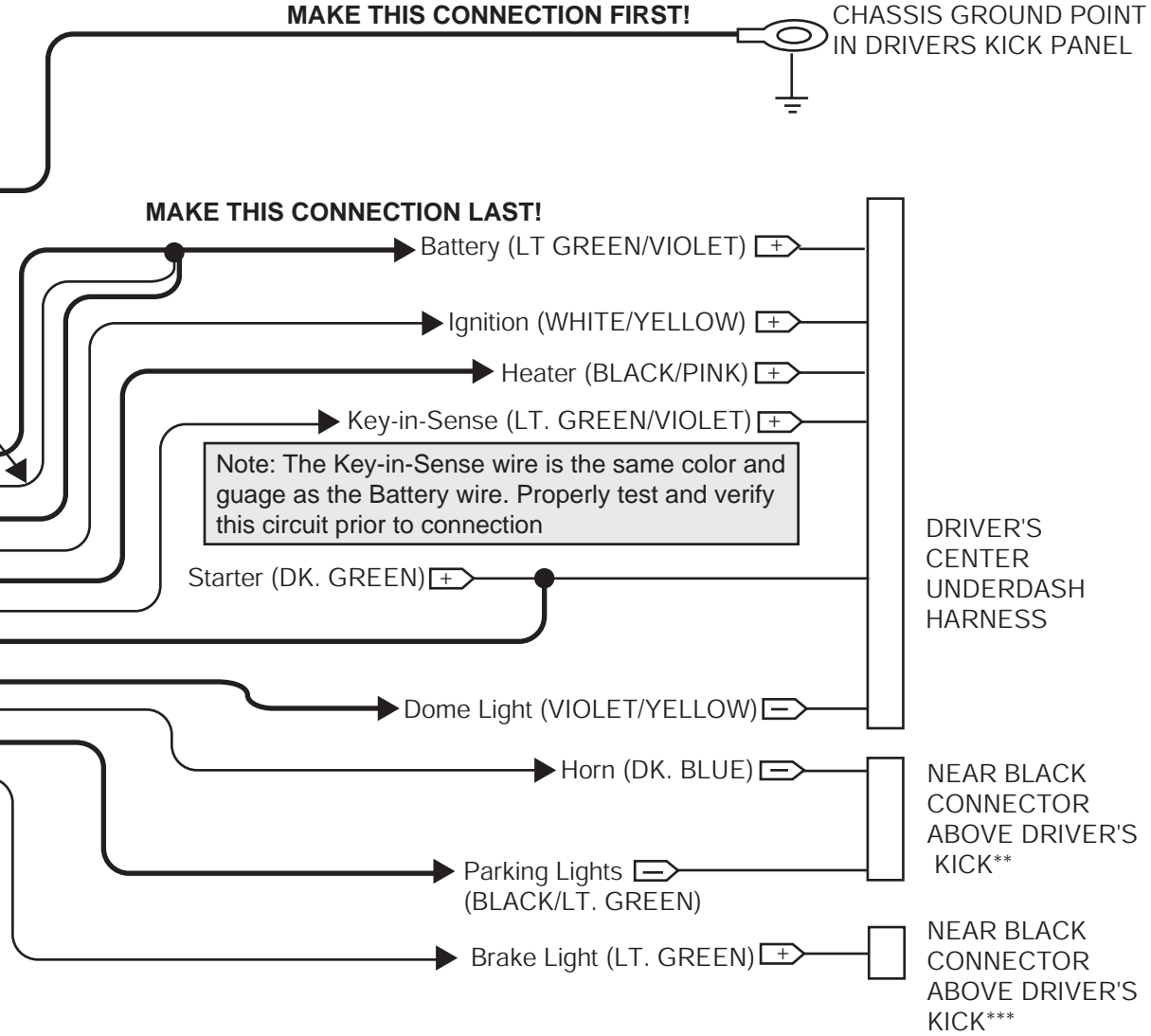

** Wire is located inside wire loom running to black connector but does not terminate. Wire can be found 4" from connector on the side heading toward the rear of the vehicle in a looped fashion underneath bright green tape.

*** Wire is located inside wire loom running to black connector but does not terminate. Wire can be found 4" from connector on the side heading toward the bulkhead of the vehicle in a looped fashion underneath bright green tape.

Vehicle (Year/Make/Model)	
'08 Mustang	
Equipment or Trim level	System(s) applicable to:
ALL	RKE/VSS/RMST
Page	Revision Date
3 of 4	6/4/07

*** Wire is located inside wire loom running to black connector but does not terminate. Wire can be found 4" from connector on the side heading toward the bulkhead of the vehicle in a looped fashion underneath bright green tape.

	Color	Function
A-10	YELLOW/WHITE	Door Ajar Switch Input
A-2	BLUE	Door Lock Output
A-14	GREEN	Door UnLock Output
A-12	LT. GREEN	Unlock Switch Sense Input
A-11	WHITE/BLUE	Arm Input
A-9	BROWN	Disarm Input
C-4	LT GREEN/BLACK	Factory Alarm Disarm
A-24	BLUE/GREEN	Driver Door Unlock Output
C-11	BLUE/WHITE	Rear Defroster Output

Optional Installation Feature
See Optional Connections page

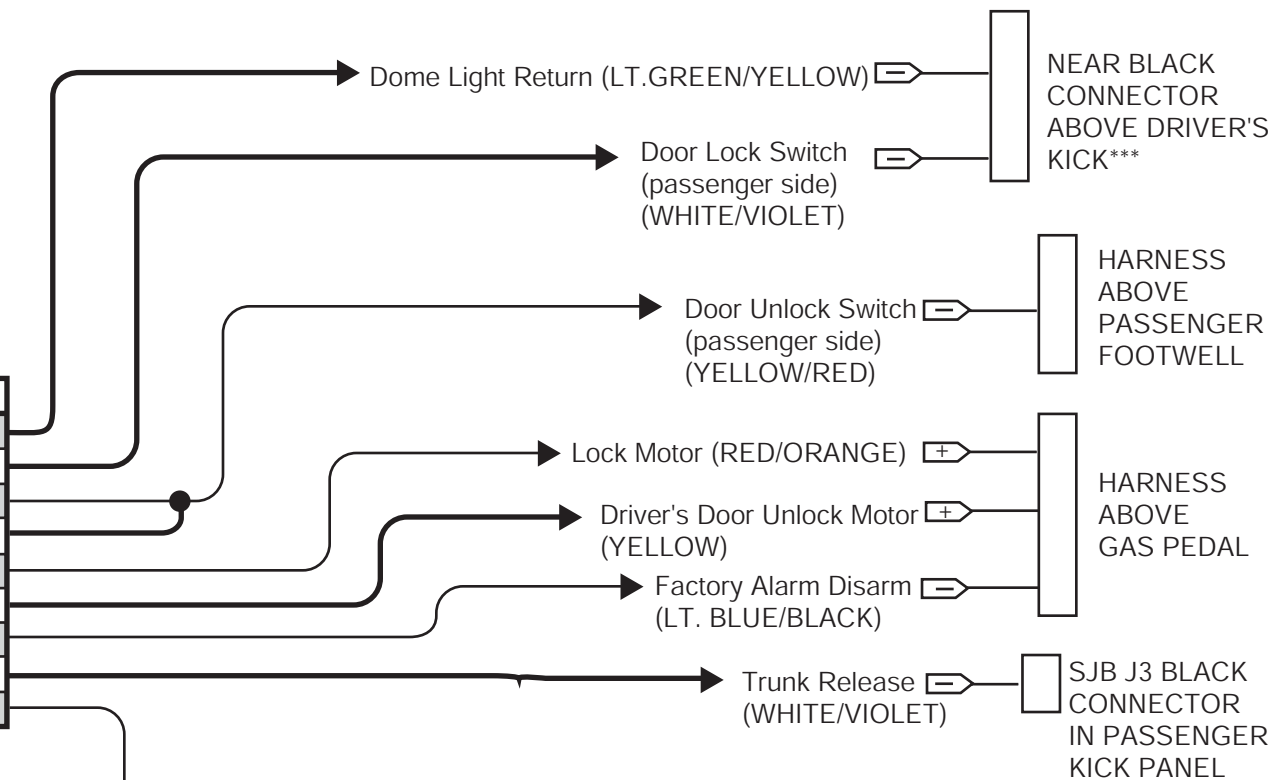

UNDERHOOD HARNESS

	Color	Function
A-19	GRAY	Hood Open Switch Input

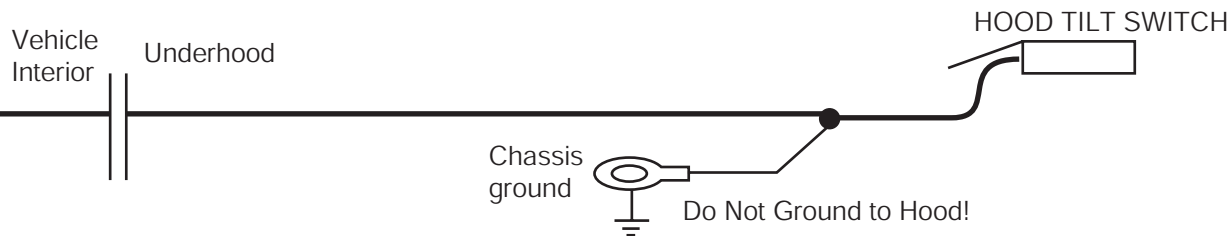

Vehicle (Year/Make/Model) '08 Mustang	
Equipment or Trim level ALL	System(s) applicable to: RKE/VSS/RMST
Page 4 of 4	Revision Date 6/4/07

OPTIONAL CONNECTIONS / FEATURES

OPTION PROGRAMMING REQUIREMENTS

BANK	OPTION	DESCRIPTION	LED
2	8	DRIVER UNLOCK RELAY	ON
3	1	DRIVER PRIORITY UNLOCK	ON

DRIVER'S DOOR PRIORITY UNLOCK

	Color	Function
C-9	TAN/RED	Driver Door Unlock Switch
A-13	TAN	Driver Door Unlock Motor
A-9	BROWN	Disarm Input

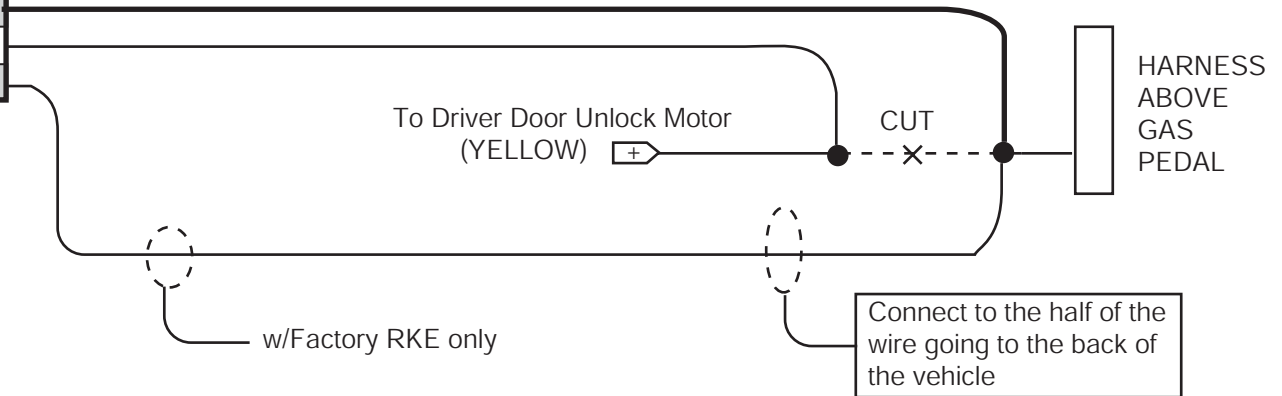

REAR DEFROSTER

	Color	Function
C-11	BLUE/WHITE	Rear Defroster Output



Vehicle (Year/Make/Model) '08 Mustang	
Equipment or Trim level ALL	System(s) applicable to: ALL
Page 1 of 2	Revision Date 6/4/07

S197 SJB Layout (Front View)
FOUND IN PASSENGER KICK PANEL

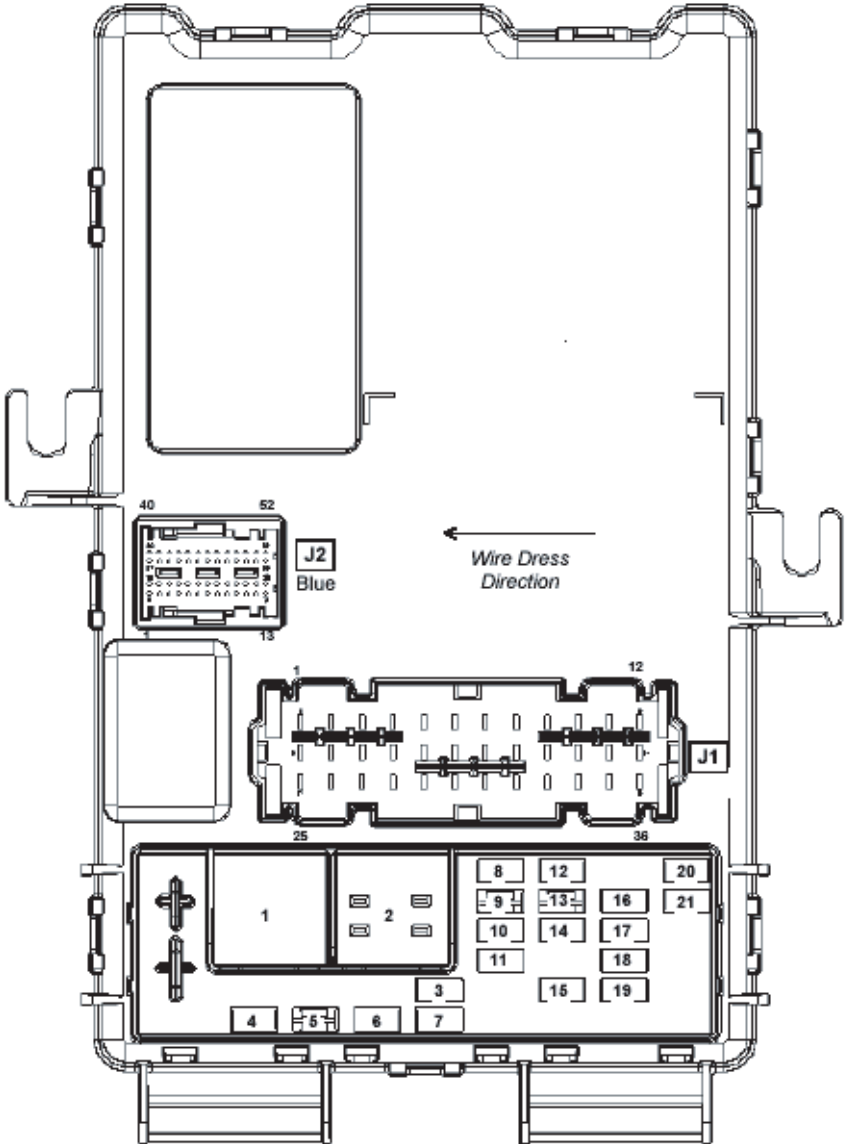

Vehicle (Year/Make/Model) '08 Mustang	
Equipment or Trim level ALL	System(s) applicable to: ALL
Page 2 of 2	Revision Date 6/4/07

S197 SJB Layout (Back View)
FOUND IN PASSENGER KICK PANEL

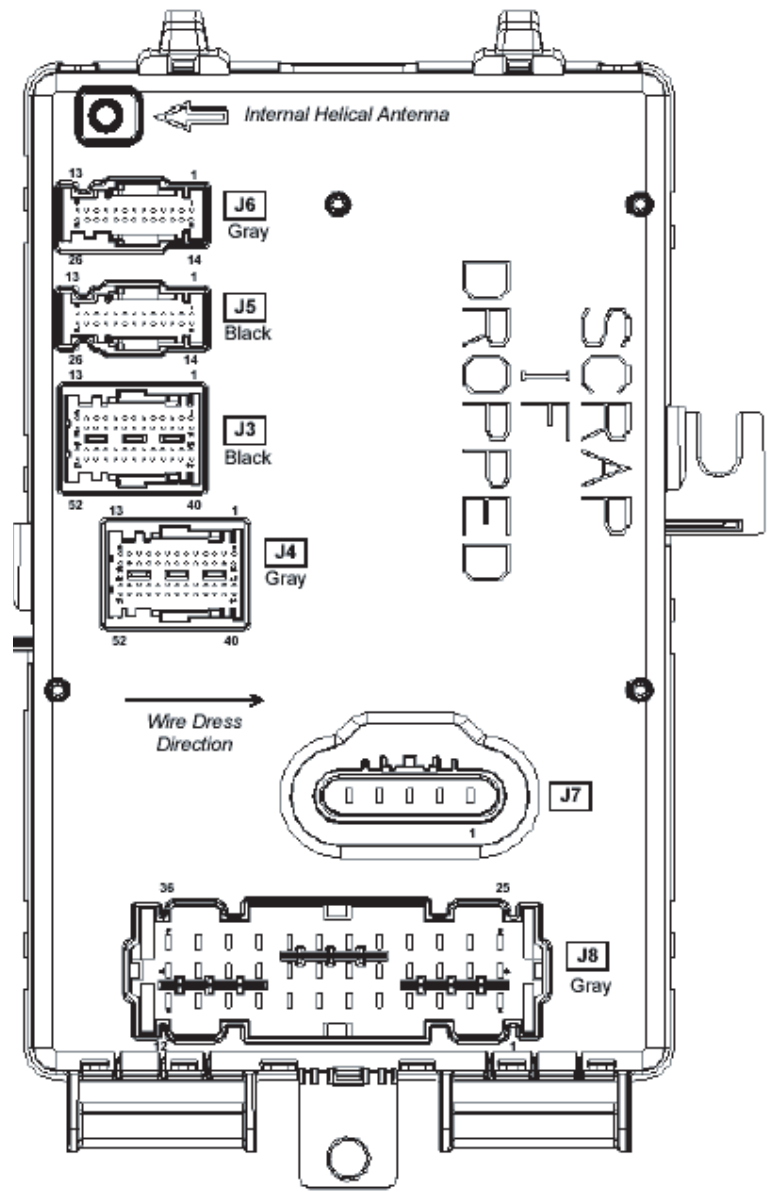

Vehicle (Year/Make/Model) '08 Mustang	
Equipment or Trim level ALL	System(s) applicable to: RMST
Page 1 of 2	Revision Date 6/4/07

Module:
PC-14
7L2Z-19G367-AA

FUSE PLACEMENT CHART

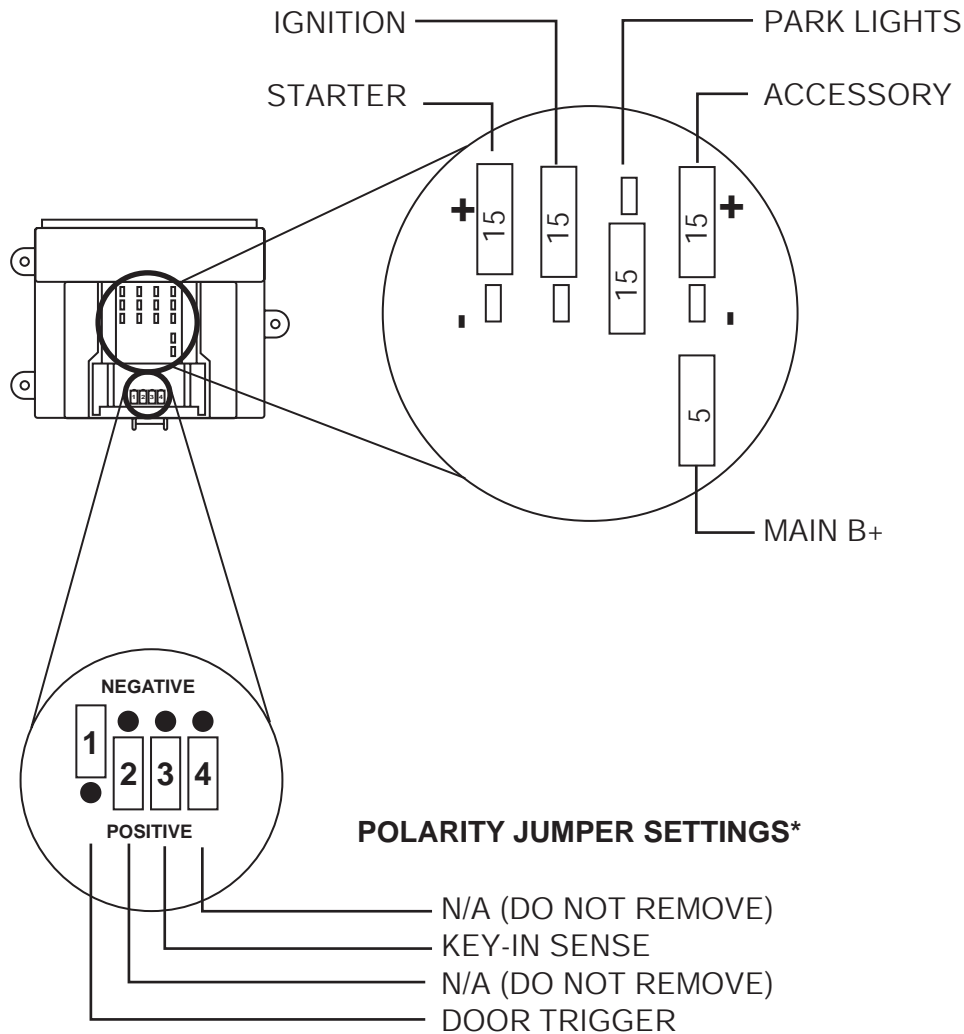

* See Polarity Jumper Section in Base Instructions for details

PARTS REQUIRED:

RMST Kit:
7L2Z-19G364-AA

Securilock (PATS) Interface:
PIK-4 (P/N: 7L2Z-19G365-AA - included)

FUNCTIONAL PROGRAMMING REQUIREMENTS

BANK	OPTION	DESCRIPTION	LED
1	2	DOOR AJAR INVERT	ON
1	3	KEY-IN SENSE INVERT	ON
2	1	TACHLESS MODE	ON

MODULE MOUNTING LOCATION:

Left Side of Driver's Underdash

Vehicle (Year/Make/Model)	
'08 Mustang	
Equipment or Trim level	System(s) applicable to:
ALL	RMST
Page	Revision Date
2 of 2	6/4/07

USE TYPE "A" CUSTOM WIRE HARNESS

VEHICLE HARNESS

IGNITION SWITCH

STEERING COLUMN HARNESS

	Color	Function
A-3	PINK	Ignition Input/Output
A-2	ORANGE	HVAC Output
A-13	VIOLET	Starter Output
B-8	BLACK/WHITE	Key-in-sense Input
A-4	RED	Battery

	Color	Function
A-21	BROWN/BLACK	Horn Relay Output
A-1	WHITE	Parking Light Output

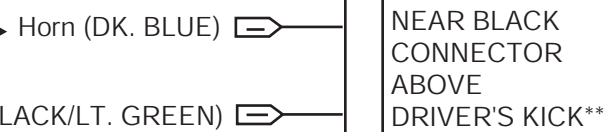

** Wire is located inside wire loom running to black connector but does not terminate. Wire can be found 4" from connector on the side heading toward the rear of the vehicle in a looped fashion underneath bright green tape.

MAKE THIS CONNECTION FIRST!

CHASSIS GROUND POINT IN DRIVER'S KICK PANEL

DRIVER'S KICK PANEL HARNESS

	Color	Function
A-5	BLACK	Ground
A-24	BLUE	Door Lock Output
A-20	GREEN/VIOLET	Door Ajar Switch Input
B-7	BROWN	Brake Input

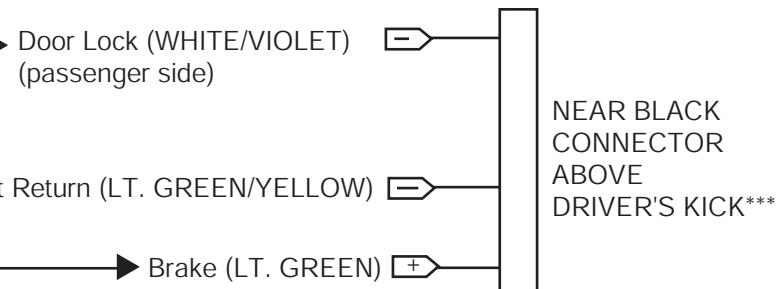

*** Wire is located inside wire loom running to black connector but does not terminate. Wire can be found 4" from connector on the side heading toward the bulkhead of the vehicle in a looped fashion underneath bright green tape.

UNDER HOOD HARNESS

	Color	Function
A-19	GRAY	Hood Open Switch Input

Vehicle Interior

Engine Compartment

Chassis Ground

Do Not Ground to Hood!

Hood Tilt Switch

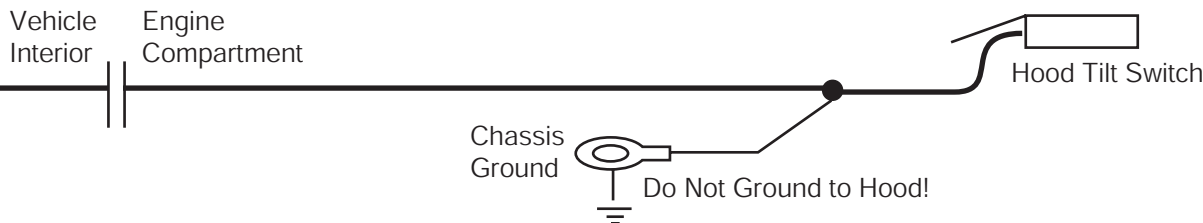

Vehicle (Year/Make/Model) '08 Mustang	
Equipment or Trim level ALL	System(s) applicable to: VSS
Page 1 of 3	Revision Date 6/4/07

Module:
PC-14
7L2Z-19G367-AA

FUSE PLACEMENT CHART

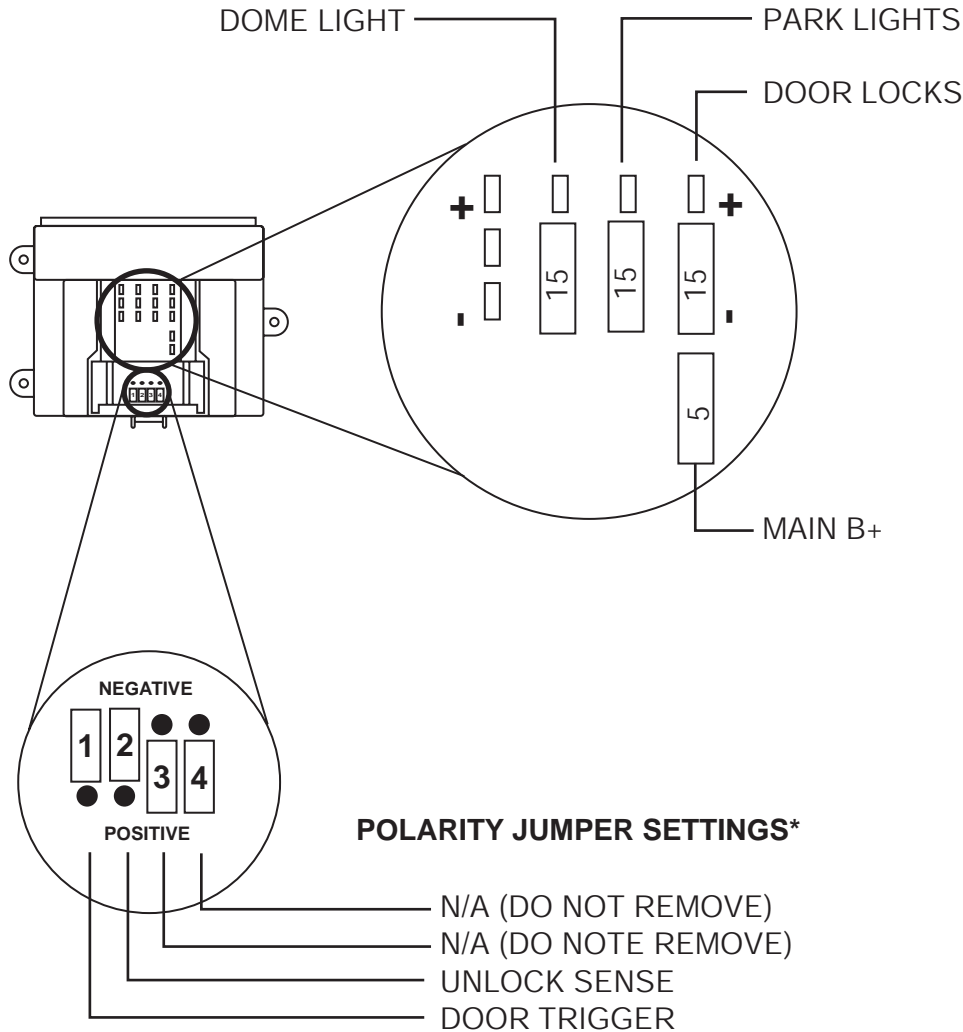

POLARITY JUMPER SETTINGS*

* See Polarity Jumper Section in Base Instructions for details

PARTS REQUIRED:

VSS Kit:
7L3Z-19A361-AA

FUNCTIONAL PROGRAMMING REQUIREMENTS

BANK	OPTION	DESCRIPTION	LED
1	1	LITE TOUCH ADJUSTMENT	note 1
1	2	FULL SHOCK ADJUSTMENT	note 1
1	4	DOOR AJAR INVERT	ON
1	5	UNLOCK SENSE INVERT	ON
2	1	STARTER INTERRUPT	OFF

Note 1: Perform proper adjustments per the "Shock Sensor Setting" section of the Base instruction sheets.

MODULE MOUNTING LOCATION:

Left Side of Driver's Underdash

NOTE:

IF USING THIS SYSTEM IN LOT MODE, WIRE HARNESS P/N 2W7Z-19C757-BA WILL HAVE TO BE ORDERED TO ACCESS THE 'FACTORY DISARM OUTPUT" WIRE (LT.GREEN/BLACK).

Vehicle (Year/Make/Model) '08 Mustang	
Equipment or Trim level ALL	System(s) applicable to: VSS
Page 2 of 3	Revision Date 6/4/07

DRIVER'S SIDE KICK PANEL HARNESS

	Color	Function
A-5	BLACK	Ground

STEERING COLUMN HARNESS

	Color	Function
A-4	RED	Battery
A-20	GREEN/VIOLET	Door Trigger Input Pull-up
A-7	PINK	Ignition 1 Input/Output
A-8	VIOLET	Starter Interrupt Motor Side
A-6	VIOLET/RED	Starter Interrupt Key Side
A-3	BLACK/WHITE	Dome Light Output
A-21	BROWN/BLACK	Horn Relay Output
A-1	WHITE	Parking Light Output

Note: Must Connect To Avoid False Alarms

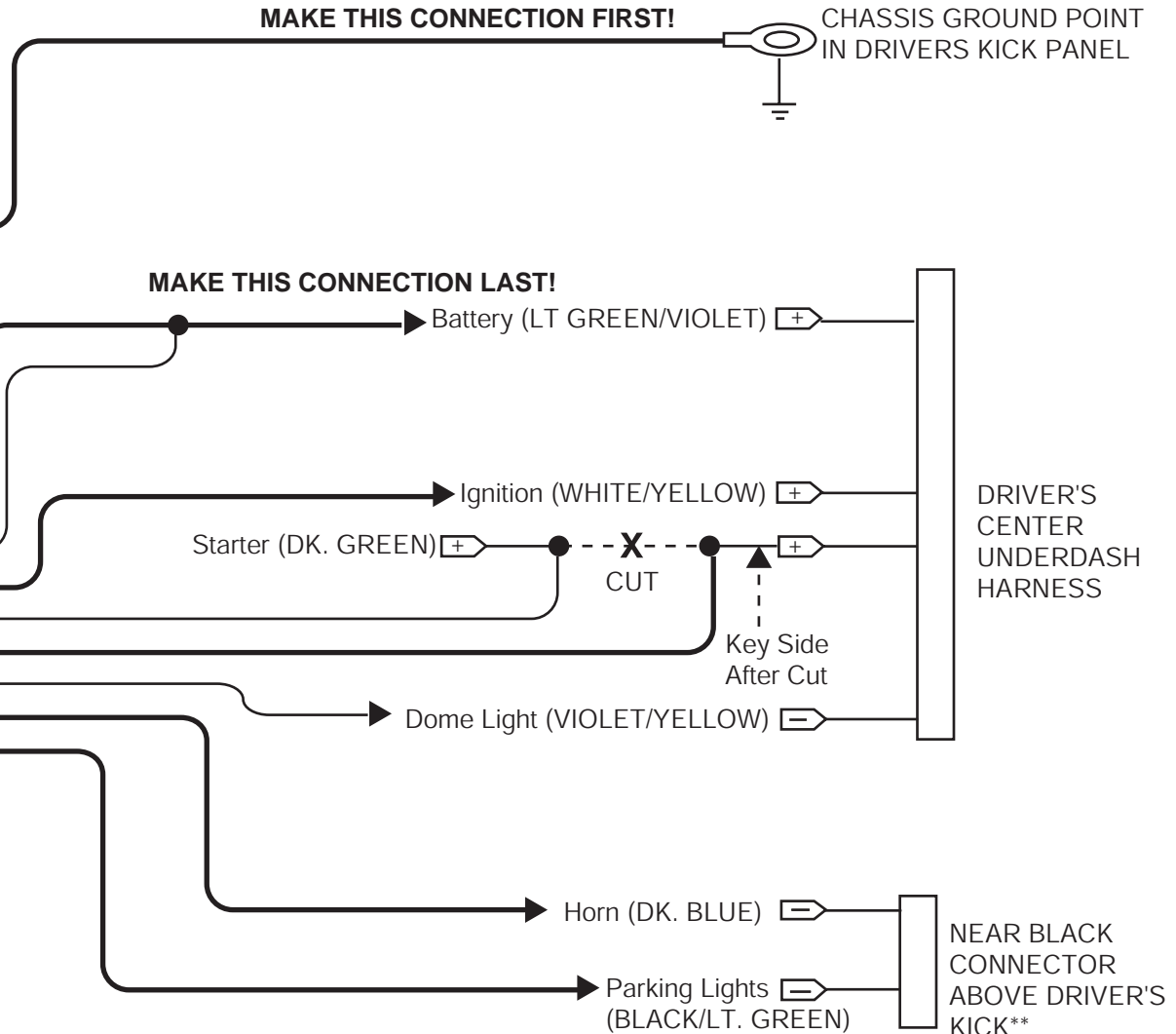

** Wire is located inside wire loom running to black connector but does not terminate. Wire can be found 4" from connector on the side heading toward the rear of the vehicle in a looped fashion underneath bright green tape.

Vehicle (Year/Make/Model)	
'08 Mustang	
Equipment or Trim level	System(s) applicable to:
ALL	VSS
Page	Revision Date
3 of 3	6/4/07

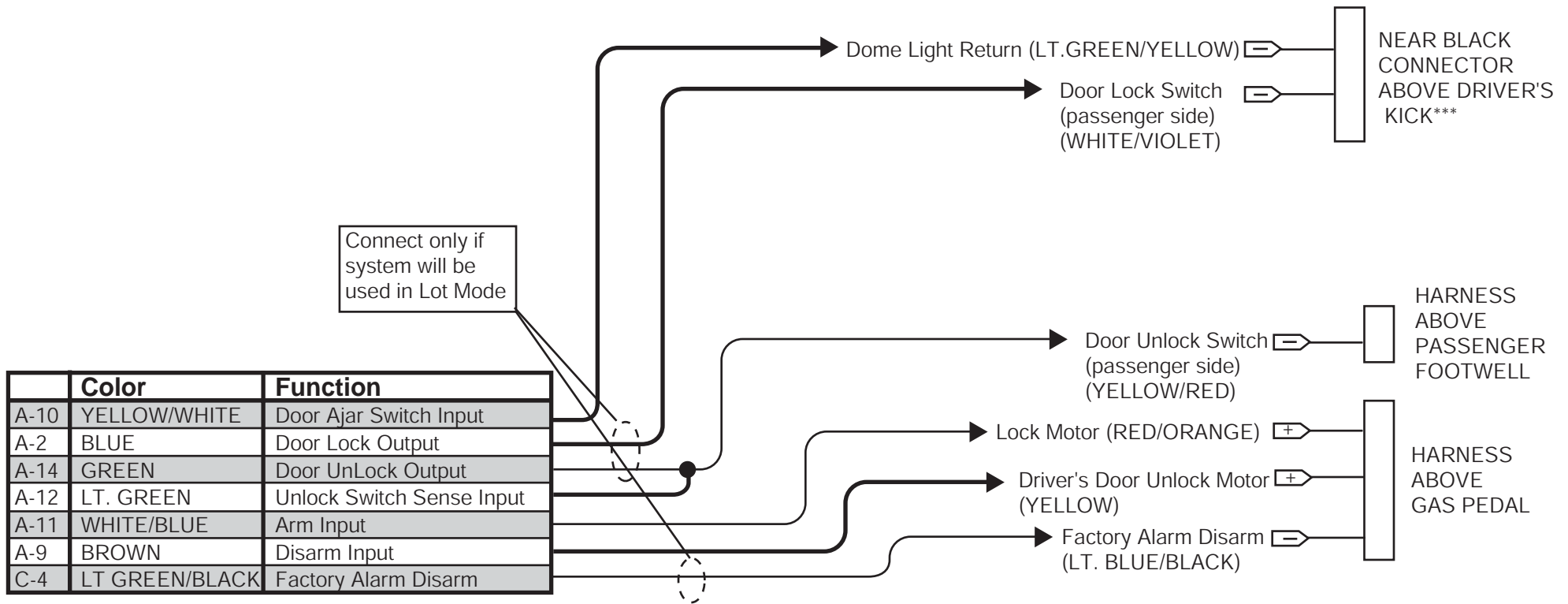

*** Wire is located inside wire loom running to black connector but does not terminate. Wire can be found 4" from connector on the side heading toward the bulkhead of the vehicle in a looped fashion underneath bright green tape.

Vehicle (Year/Make/Model) '08 MKZ	
Equipment or Trim level ALL	System(s) applicable to: RMST
Page 1 of 3	Revision Date 7/9/07

Module:
PC-14
7L2Z-19G367-AA

FUSE PLACEMENT CHART

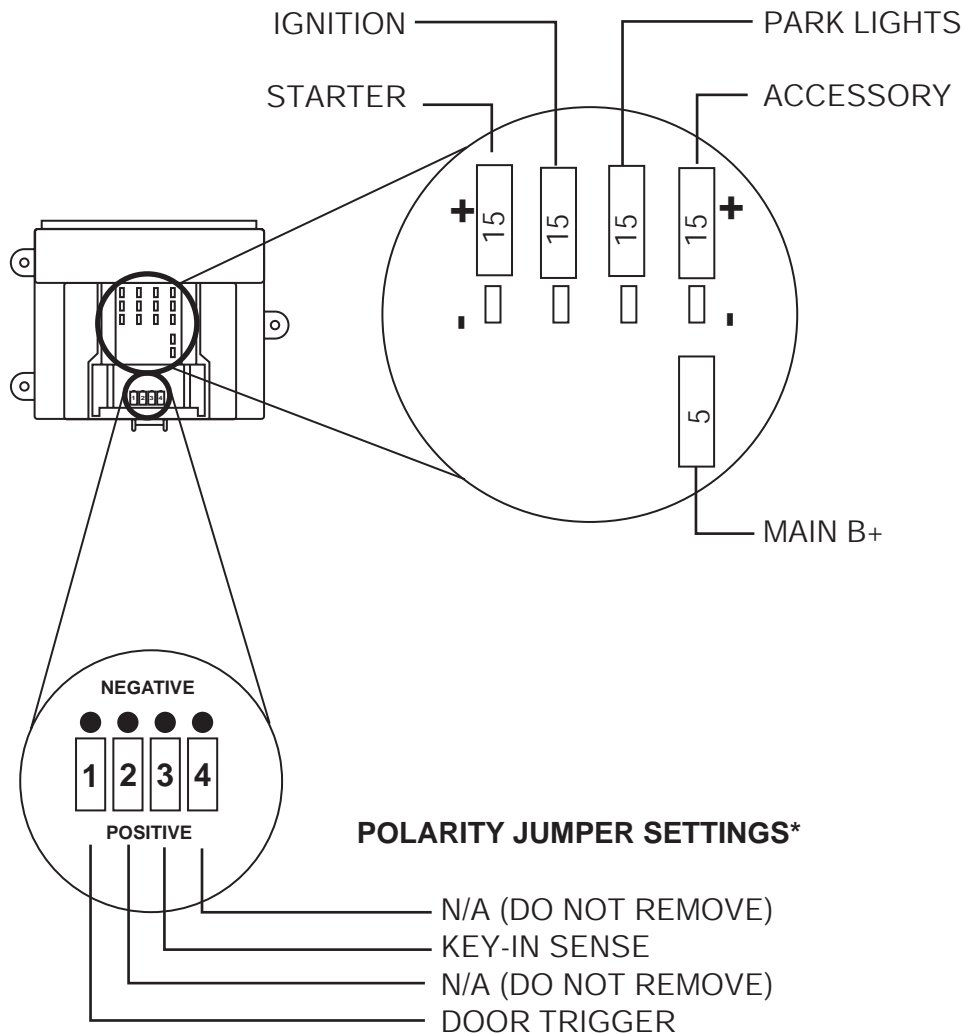

POLARITY JUMPER SETTINGS*

* See Polarity Jumper Section in Base Instructions for details

PARTS REQUIRED:

RMST Kit:
7L2Z-19G364-AA

Securilock (PATS) Interface:
PIK-4 (P/N: 7L2Z-19G365-AA - included)

FUNCTIONAL PROGRAMMING REQUIREMENTS

BANK	OPTION	DESCRIPTION	LED
1	2	DOOR AJAR INVERT	ON
1	3	KEY-IN SENSE INVERT	ON
2	1	TACHLESS MODE	ON

MODULE MOUNTING LOCATION:

Left Side of Driver's Underdash

Vehicle (Year/Make/Model)	
'08 MKZ	
Equipment or Trim level	System(s) applicable to:
ALL	RMST
Page	Revision Date
2 of 3	7/9/07

USE TYPE "A" CUSTOM WIRE HARNESS

VEHICLE HARNESS

IGNITION SWITCH

STEERING COLUMN HARNESS

	Color	Function
A-3	PINK	Ignition Input/Output
A-2	ORANGE	HVAC Output
A-13	VIOLET	Starter Output
B-8	BLACK/WHITE	Key-in-sense Input
A-4	RED	Battery

	Color	Function
A-21	BROWN/BLACK	Horn Relay Output

Horn (BLUE/WHITE)

STEERING COLUMN HARNESS

DRIVER'S KICK PANEL HARNESS

	Color	Function
A-5	BLACK	Ground
B-7	BROWN	Brake Input
A-20	GREEN/VIOLET	Door Ajar Switch Input
A-1	WHITE	Parking Light Output

MAKE THIS CONNECTION FIRST!

CHASSIS GROUND POINT IN DRIVER'S KICK PANEL

Brake (YELLOW/GRAY)

DRIVERS KICK PANEL

Dome Light (BLUE)

Parking Lights On (GRAY/YELLOW)

UNDER HOOD HARNESS

	Color	Function
A-19	GRAY	Hood Open Switch Input

Vehicle Interior

Engine Compartment

Hood Tilt Switch

Chassis Ground

Do Not Ground to Hood!

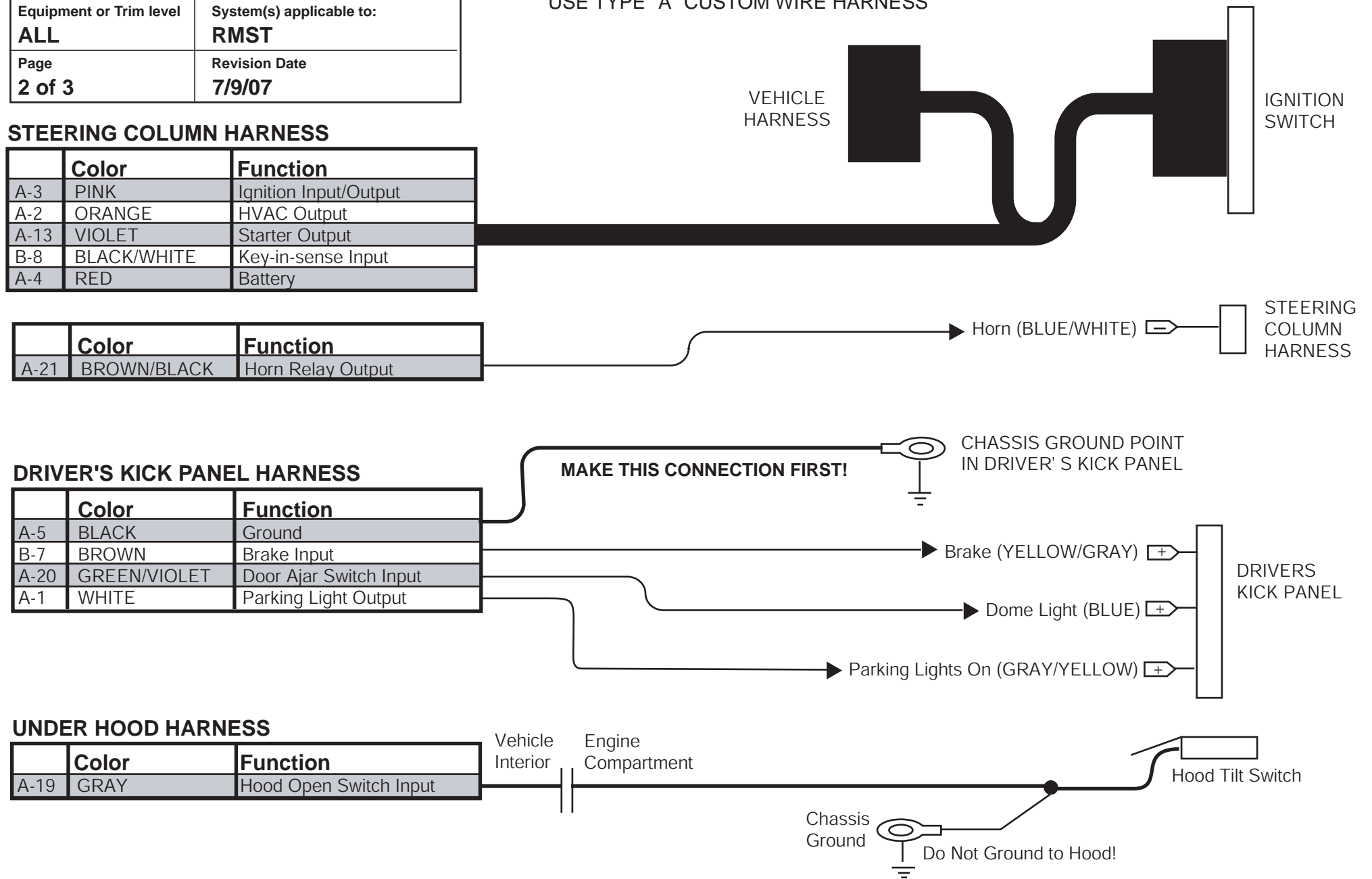

Vehicle (Year/Make/Model) '08 MKZ	
Equipment or Trim level ALL	System(s) applicable to: RMST
Page 3 of 3	Revision Date 7/9/07

(SJB)

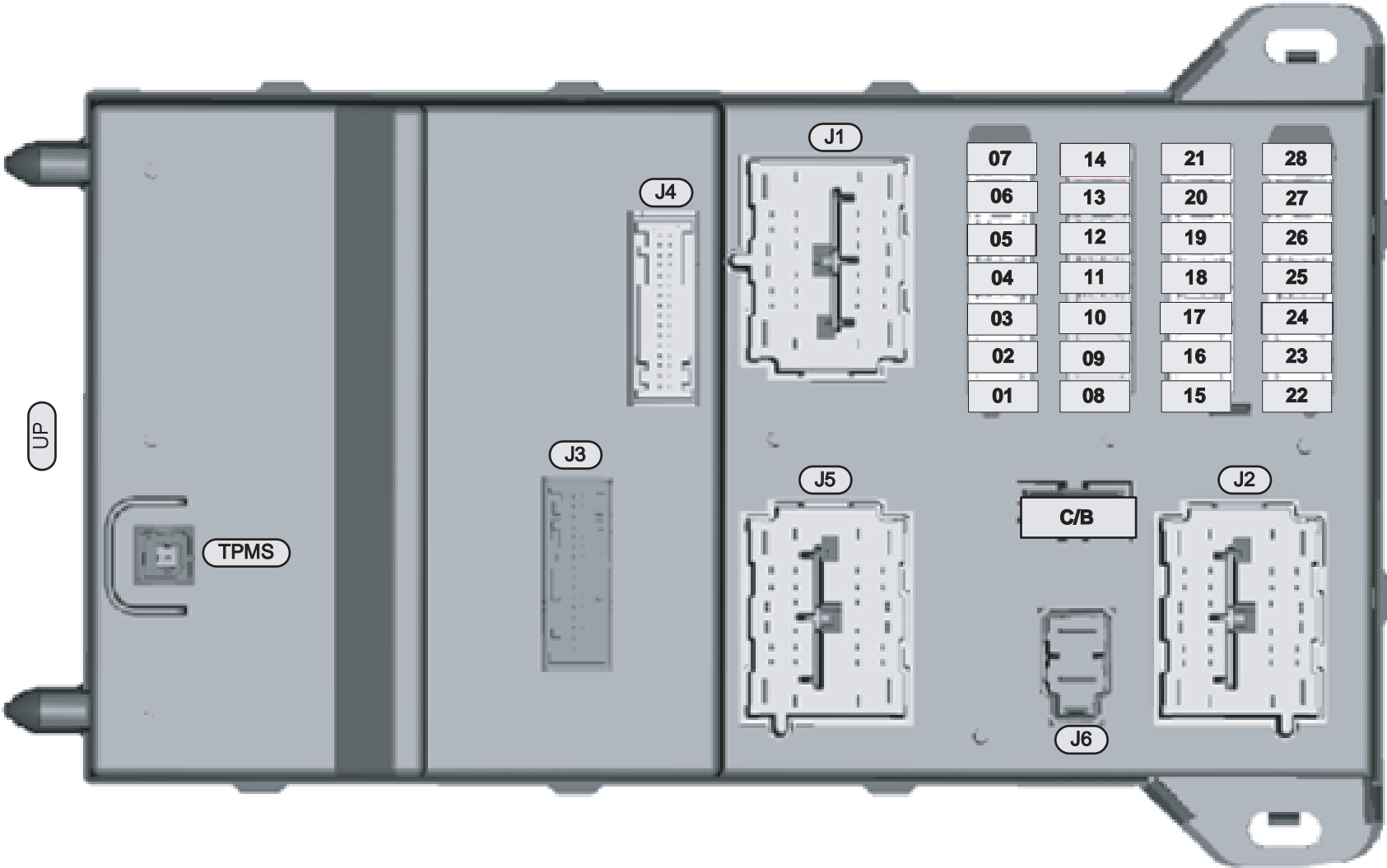

Vehicle (Year/Make/Model) '08 Fusion / Milan	
Equipment or Trim level ALL	System(s) applicable to: RKE/VSS/RMST
Page 1 of 4	Revision Date 7/9/07

Module:
PC-34
7L3Z-19G367-AA

FUSE PLACEMENT CHART

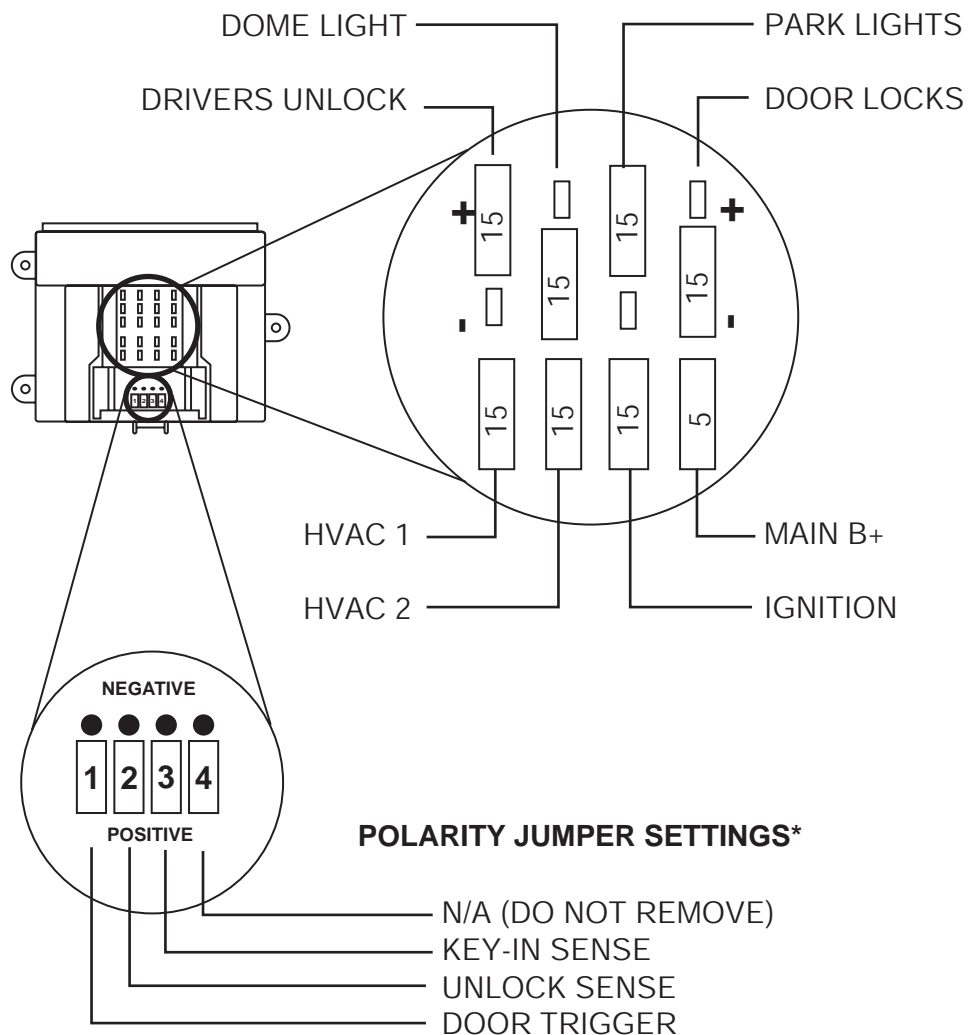

* See Polarity Jumper Section in Base Instructions for details

IMPORTANT: This Series 200 kit is NOT recommended for installation on this vehicle because the alarm system will trigger if the Integrated Keyfob is used to open the trunk/liftgate without disarming the Series 200 system first. Therefore, it is highly recommended to install the Series 100 system (7L2Z-19G364-AA) instead, which is not equipped with perimeter security.

PARTS REQUIRED:

RKE/VSS/RMST Kit:

7L3Z-19G364-AA

Securilock (PATS) Interface:

PIK-4 (P/N: 7L2Z-19G365-AA - order separately)

FUNCTIONAL PROGRAMMING REQUIREMENTS

BANK	OPTION	DESCRIPTION	LED
1	1	LITE TOUCH ADJUSTMENT	note 1
1	2	FULL SHOCK ADJUSTMENT	note 1
1	4	DOOR AJAR INVERT	ON
1	5	UNLOCK SENSE INVERT	ON
1	6	KEY-IN SENSE INVERT	ON
2	1	STARTER INTERRUPT	OFF
2	8	DRIVER UNLOCK RELAY	note 2
3	1	DRIVER PRIORITY UNLOCK	note 2
4	1	TACHLESS MODE	ON

Note 1: Perform proper adjustments per the "Shock Sensor Setting" section of the Base instruction sheets.

Note 2: See the Optional Connections / Features page

MODULE MOUNTING LOCATION:

Left Side of Driver's Underdash

Vehicle (Year/Make/Model) '08 Fusion / Milan	
Equipment or Trim level ALL	System(s) applicable to: RKE/VSS/RMST
Page 2 of 4	Revision Date 7/9/07

STEERING COLUMN HARNESS

	Color	Function
A-4	RED	Battery
B-2	RED	HVAC1 Battery Feed
A-7	PINK	Ignition 1 Input/Output
B-4	ORANGE	HVAC1 Output
B-8	BLACK/WHITE	Key-in-sense Input
A-8	VIOLET	Starter Interrupt Motor Side
A-21	BROWN/BLACK	Horn Relay Output
B-7	BROWN	Brake Input

MAKE THIS CONNECTION LAST!

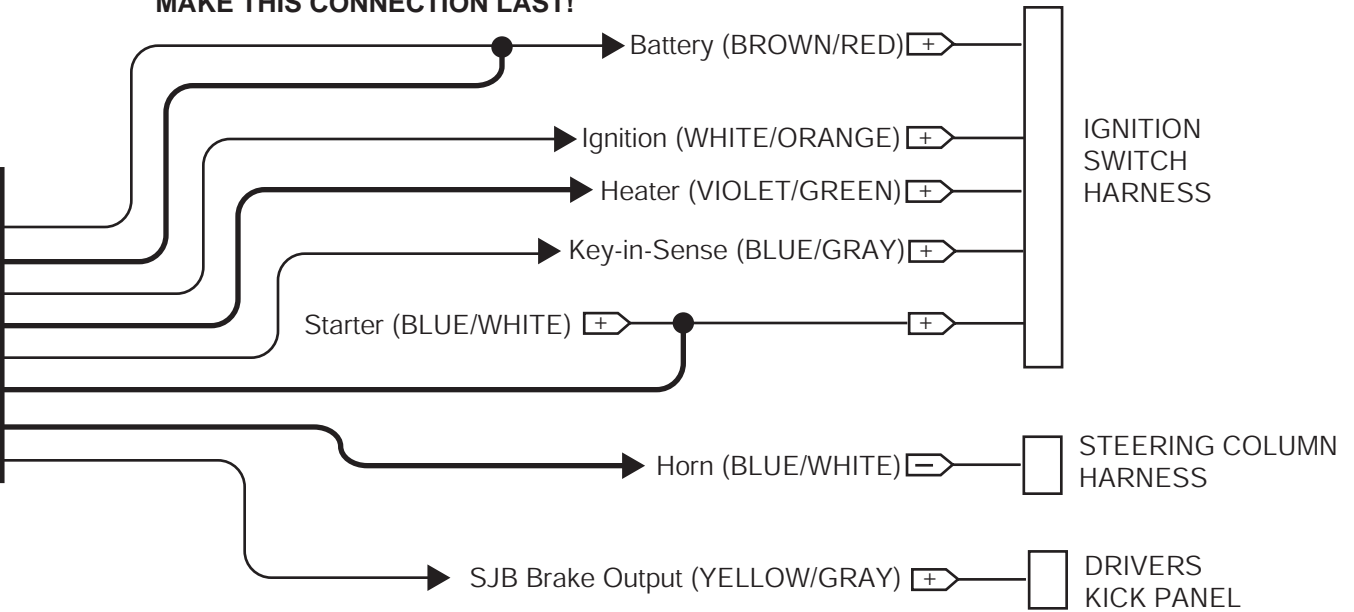

UNDERHOOD HARNESS

	Color	Function
A-19	GRAY	Hood Open Switch Input

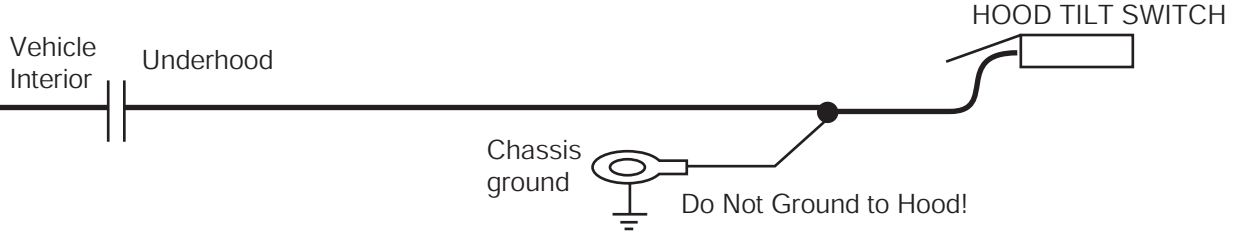

Vehicle (Year/Make/Model) '08 Fusion / Milan	
Equipment or Trim level ALL	System(s) applicable to: RKE/VSS/RMST
Page 3 of 4	Revision Date 7/9/07

MAKE THIS CONNECTION FIRST!

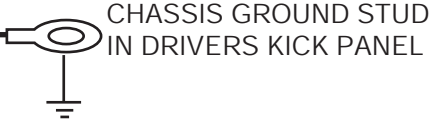

DRIVER'S SIDE KICK PANEL HARNESS

	Color	Function
A-5	BLACK	Ground

See "SJB Layout" page for connector locations.

KICK PANEL HARNESS

	Color	Function
A-20	GREEN/VIOLET	Door Ajar Switch Input
A-1	WHITE	Parking Light Output
A-11	WHITE/BLUE	Arm Input
A-2	BLUE	Door Lock Output
A-14	GREEN	Door Unlock Output
A-12	LT. GREEN	Unlock Switch Sense Input
A-9	BROWN	Disarm Input
C-4	LT GREEN/BLACK	Factory Alarm Disarm
A-24	BLUE/GREEN	Trunk Release Output
A-3	BLACK/WHITE	Dome Light Output

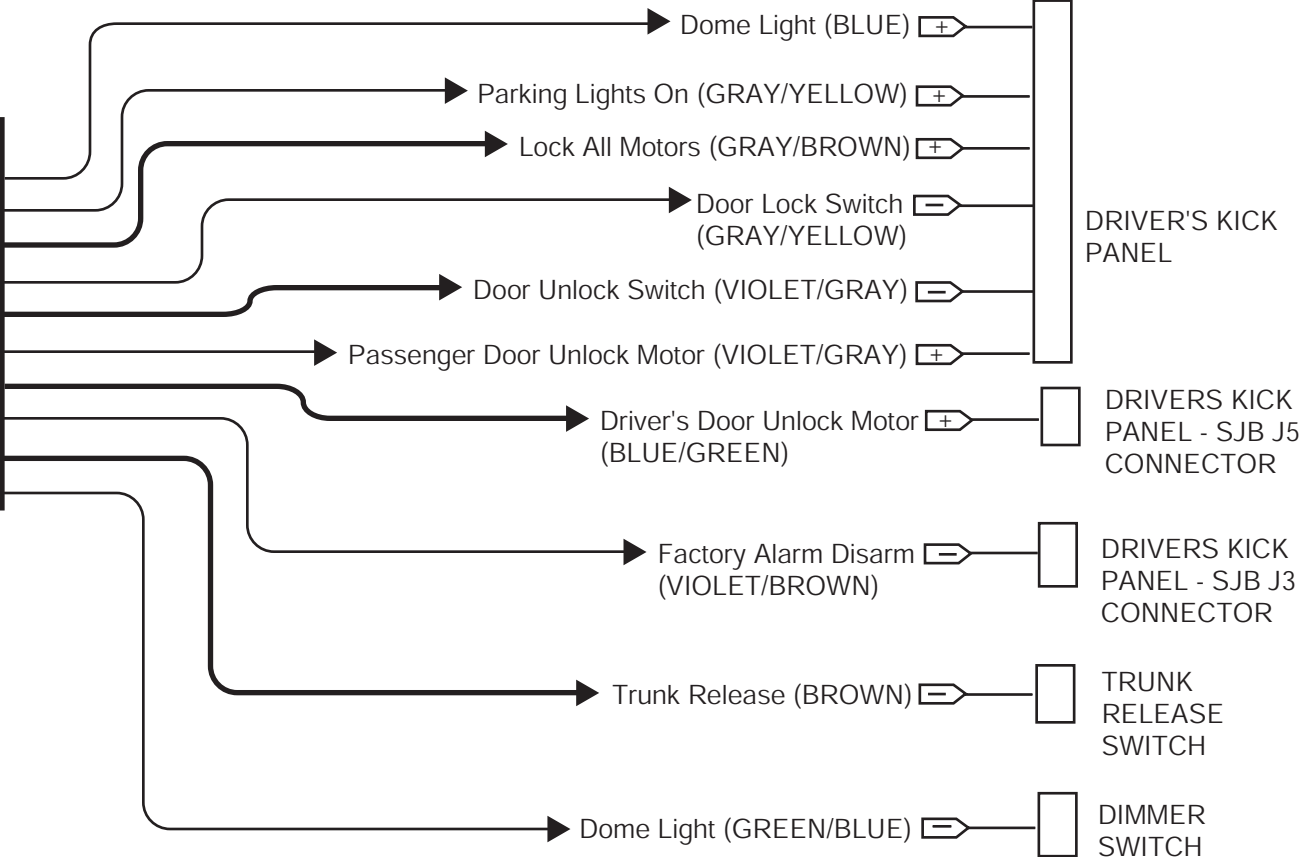

Vehicle (Year/Make/Model) '08 Fusion / Milan	
Equipment or Trim level ALL	System(s) applicable to: RKE/VSS/RMST
Page 4 of 4	Revision Date 7/9/07

OPTIONAL CONNECTIONS / FEATURES

OPTION PROGRAMMING REQUIREMENTS

BANK	OPTION	DESCRIPTION	LED
2	8	DRIVER UNLOCK RELAY	ON
3	1	DRIVER PRIORITY UNLOCK	ON

DRIVER'S DOOR PRIORITY UNLOCK

	Color	Function
C-9	TAN/RED	Driver Door Unlock Switch
A-13	TAN	Driver Door Unlock Motor
A-9	BROWN	Disarm Input

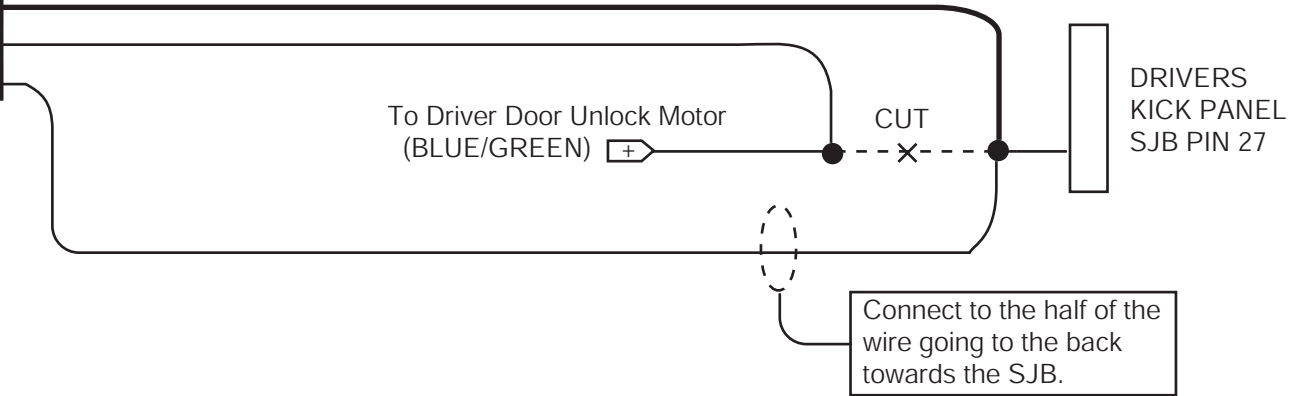

HEADLIGHTS/REAR DEFROSTER

	Color	Function
C-10	RED/WHITE	Headlight Output
C-11	BLUE/WHITE	Rear Defroster Output

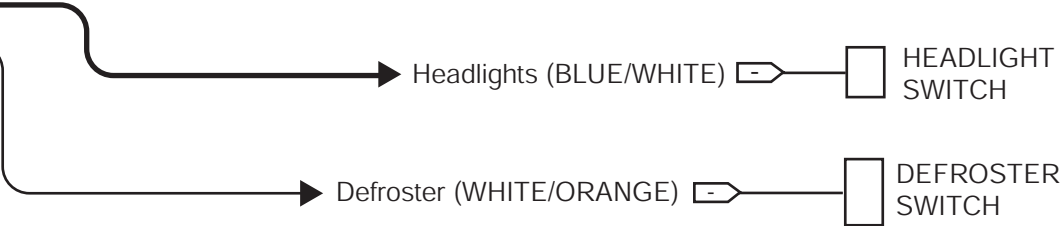

Vehicle (Year/Make/Model) '08 Fusion / Milan	
Equipment or Trim level ALL	System(s) applicable to: RMST
Page 1 of 2	Revision Date 7/9/07

Module:
PC-14
7L2Z-19G367-AA

FUSE PLACEMENT CHART

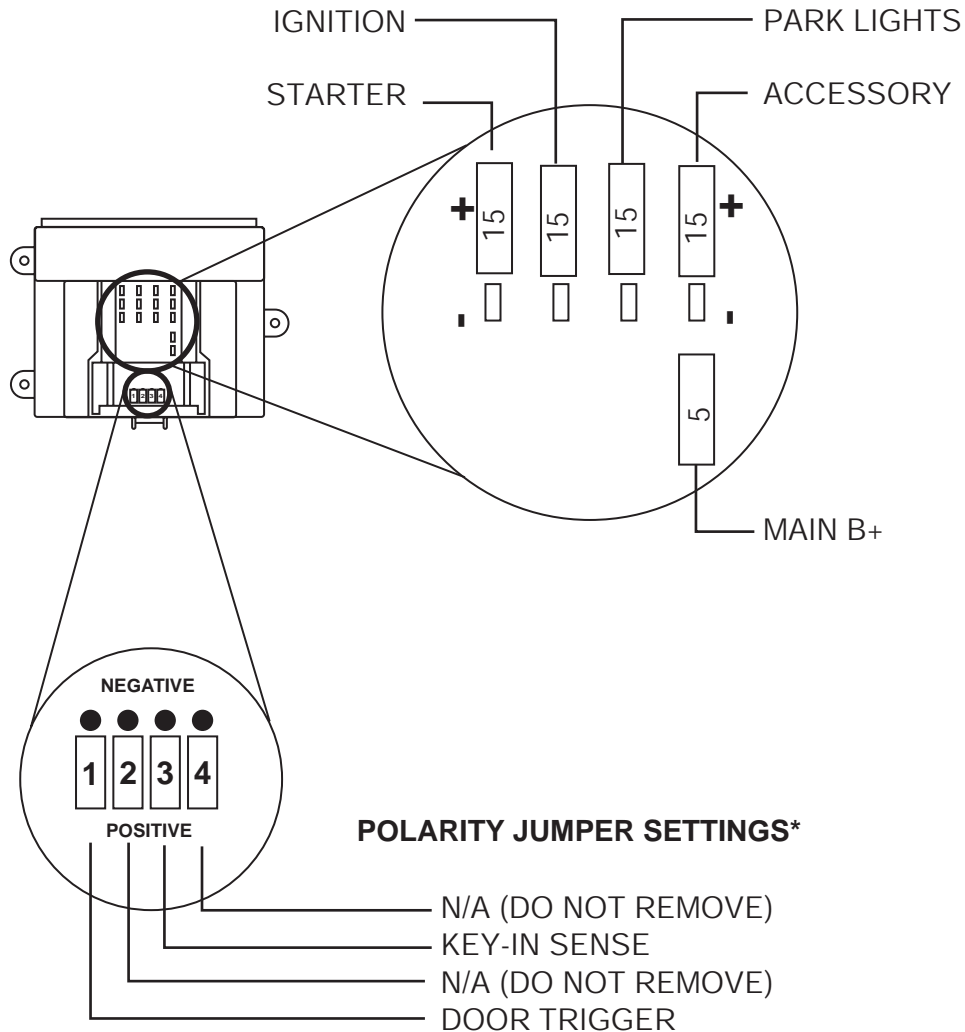

* See Polarity Jumper Section in Base Instructions for details

PARTS REQUIRED:

RMST Kit:
7L2Z-19G364-AA

Securilock (PATS) Interface:
PIK-4 (P/N: 7L2Z-19G365-AA - included)

FUNCTIONAL PROGRAMMING REQUIREMENTS

BANK	OPTION	DESCRIPTION	LED
1	2	DOOR AJAR INVERT	ON
1	3	KEY-IN SENSE INVERT	ON
2	1	TACHLESS MODE	ON

MODULE MOUNTING LOCATION:

Left Side of Driver's Underdash

Vehicle (Year/Make/Model) '08 Fusion / Milan	
Equipment or Trim level ALL	System(s) applicable to: RMST
Page 2 of 2	Revision Date 7/9/07

USE TYPE "A" CUSTOM WIRE HARNESS

VEHICLE HARNESS

IGNITION SWITCH

STEERING COLUMN HARNESS

	Color	Function
A-3	PINK	Ignition Input/Output
A-2	ORANGE	HVAC Output
A-13	VIOLET	Starter Output
B-8	BLACK/WHITE	Key-in-sense Input
A-4	RED	Battery

	Color	Function
A-21	BROWN/BLACK	Horn Relay Output

Horn (BLUE/WHITE)

STEERING COLUMN HARNESS

DRIVER'S KICK PANEL HARNESS

	Color	Function
A-5	BLACK	Ground
A-24	BLUE	Door Lock Output
B-7	BROWN	Brake Input
A-20	GREEN/VIOLET	Door Ajar Switch Input
A-1	WHITE	Parking Light Output

MAKE THIS CONNECTION FIRST!

CHASSIS GROUND POINT IN DRIVER'S KICK PANEL



Door Lock (GRAY/YELLOW)

Brake (YELLOW/GRAY)

Dome Light (BLUE)

Parking Lights On (GRAY/YELLOW)

DRIVERS KICK PANEL

UNDER HOOD HARNESS

	Color	Function
A-19	GRAY	Hood Open Switch Input

Vehicle Interior

Engine Compartment

Hood Tilt Switch

Chassis Ground

Do Not Ground to Hood!

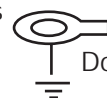

Vehicle (Year/Make/Model) '08 Fusion / Milan	
Equipment or Trim level ALL	System(s) applicable to: VSS
Page 1 of 2	Revision Date 7/9/07

Module:
PC-14
7L2Z-19G367-AA

FUSE PLACEMENT CHART

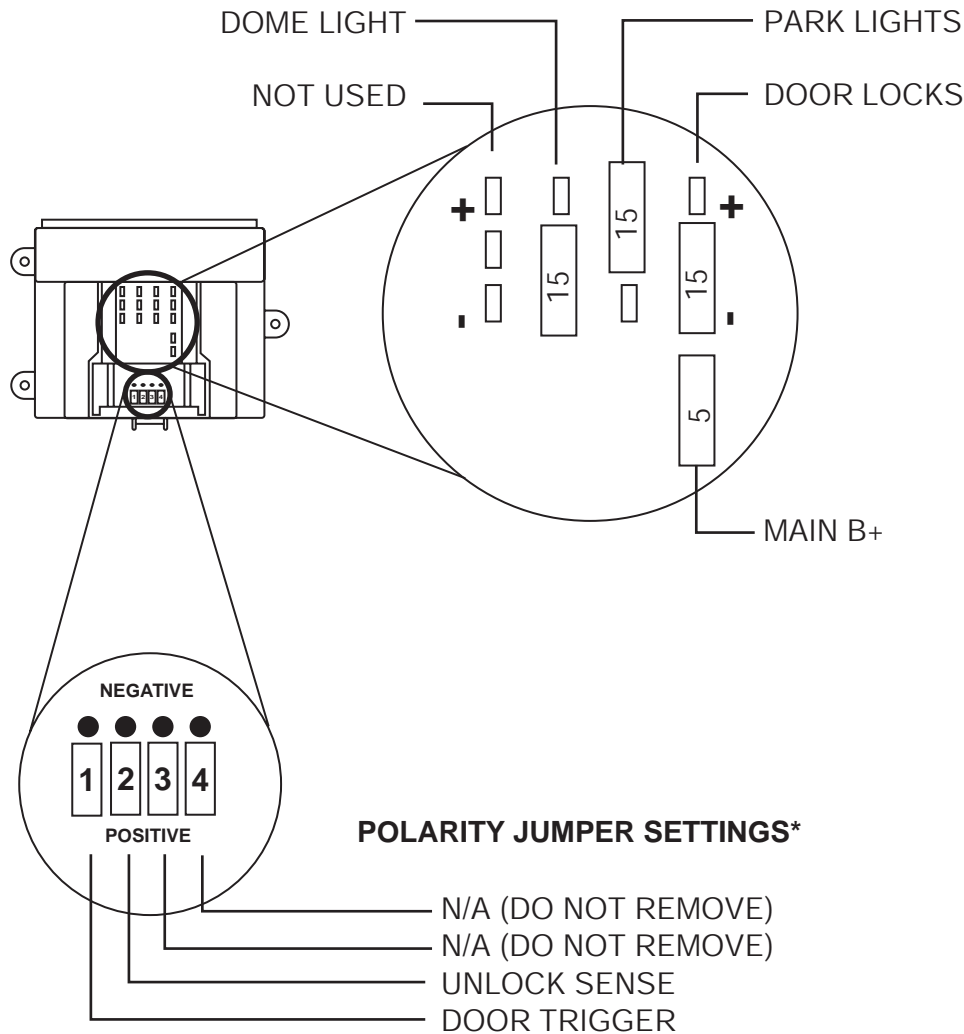

* See Polarity Jumper Section in Base Instructions for details

PARTS REQUIRED:

VSS Kit:
7L3Z-19A361-AA

FUNCTIONAL PROGRAMMING REQUIREMENTS

BANK	OPTION	DESCRIPTION	LED
1	1	LITE TOUCH ADJUSTMENT	note 1
1	2	FULL SHOCK ADJUSTMENT	note 1
1	4	DOOR AJAR INVERT	ON
1	5	UNLOCK SENSE INVERT	ON
2	1	STARTER INTERRUPT	ON

Note 1: Perform proper adjustments per the "Shock Sensor Setting" section of the Base instruction sheets.

MODULE MOUNTING LOCATION:

Left Side of Driver's Underdash

NOTE:

IF USING THIS SYSTEM IN LOT MODE, WIRE HARNESS P/N 2W7Z-19C757-BA WILL HAVE TO BE ORDERED TO ACCESS THE 'FACTORY DISARM OUTPUT" WIRE (LT.GREEN/BLACK).

Vehicle (Year/Make/Model) '08 Fusion / Milan	
Equipment or Trim level w/ factory RKE	System(s) applicable to: VSS
Page 2 of 2	Revision Date 7/9/07

STEERING COLUMN HARNESS

	Color	Function
A-4	RED	Battery
A-7	PINK	Ignition 1 Input/Output
A-8	VIOLET	Starter Interrupt Motor Side
A-6	VIOLET/RED	Starter Interrupt Key Side
A-21	BROWN/BLACK	Horn Relay Output

MAKE THIS CONNECTION LAST!

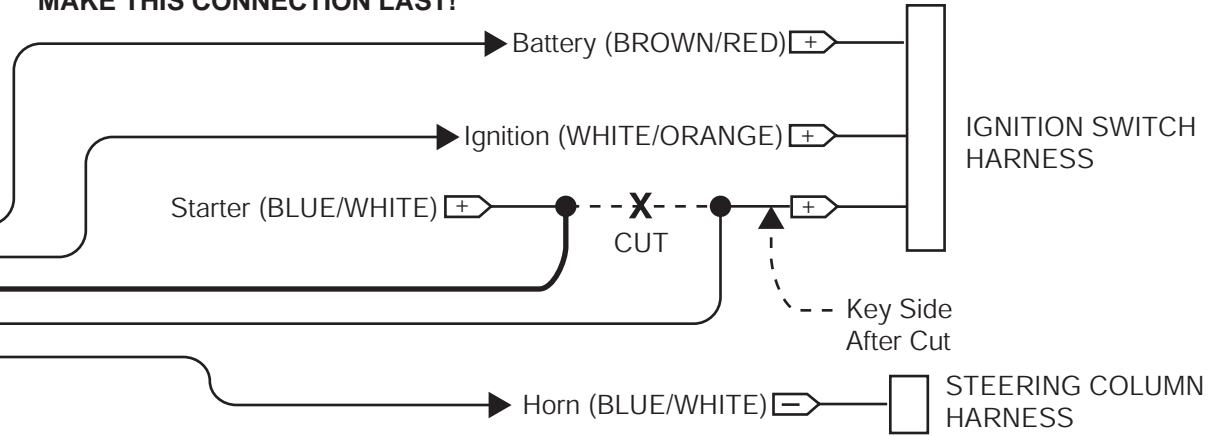

DRIVER'S SIDE KICK PANEL HARNESS

	Color	Function
A-5	BLACK	Ground

MAKE THIS CONNECTION FIRST!



KICK PANEL HARNESS

	Color	Function
A-1	WHITE	Parking Light Output
A-20	GREEN/VIOLET	Door Ajar Switch Input
A-11	WHITE/BLUE	Arm Input
A-2	BLUE	Door Lock Output
A-14	GREEN	Door Unlock Output
A-12	LT. GREEN	Unlock Switch Sense Input
A-9	BROWN	Disarm Input
C-4	LT GREEN/BLACK	Factory Alarm Disarm

Connect only if system will be used in Lot Mode

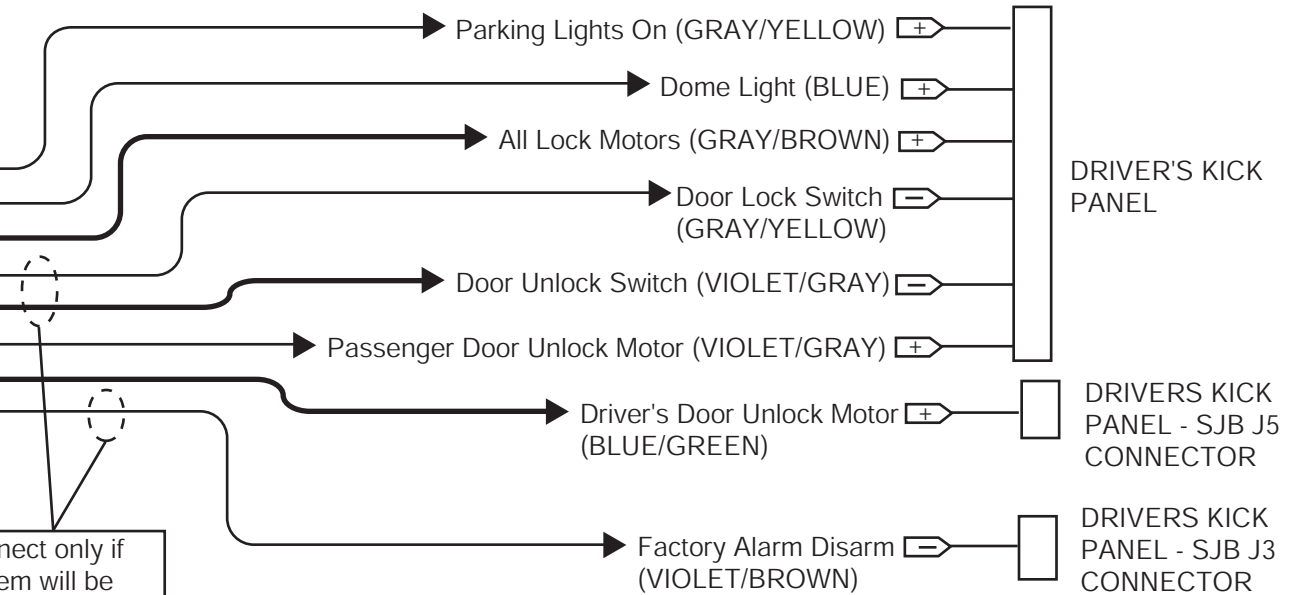

See "SJB Layout" page for connector locations.

Vehicle (Year/Make/Model) '08 Fusion / Milan	
Equipment or Trim level ALL	System(s) applicable to: ALL
Page 1 of 1	Revision Date 7/9/07

(SJB)

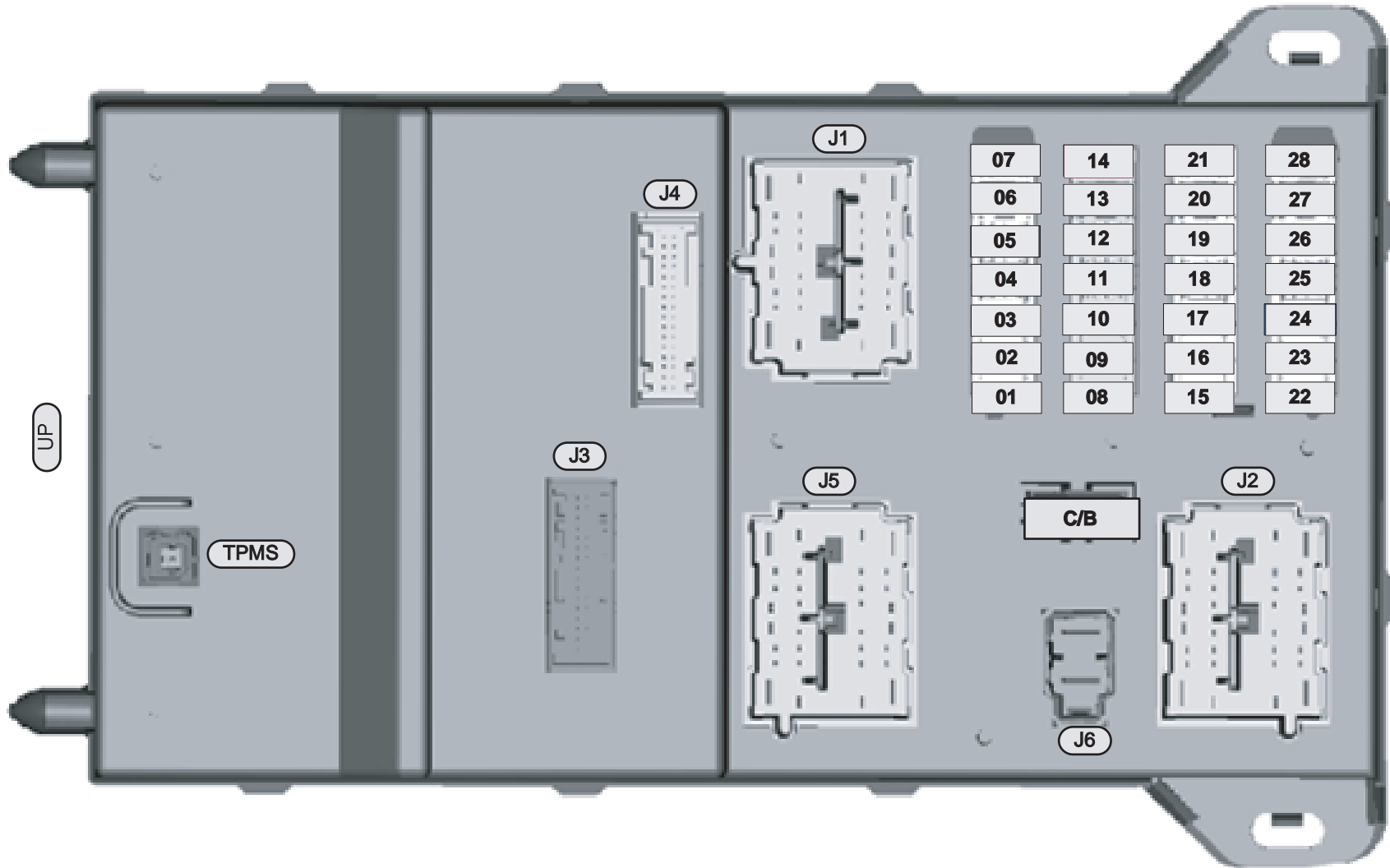

Vehicle (Year/Make/Model) '08 Focus	
Equipment or Trim level ALL	System(s) applicable to: RKE/VSS/RMST
Page 1 of 4	Revision Date 8/10/07

Module:
PC-34
7L3Z-19G367-AA

FUSE PLACEMENT CHART

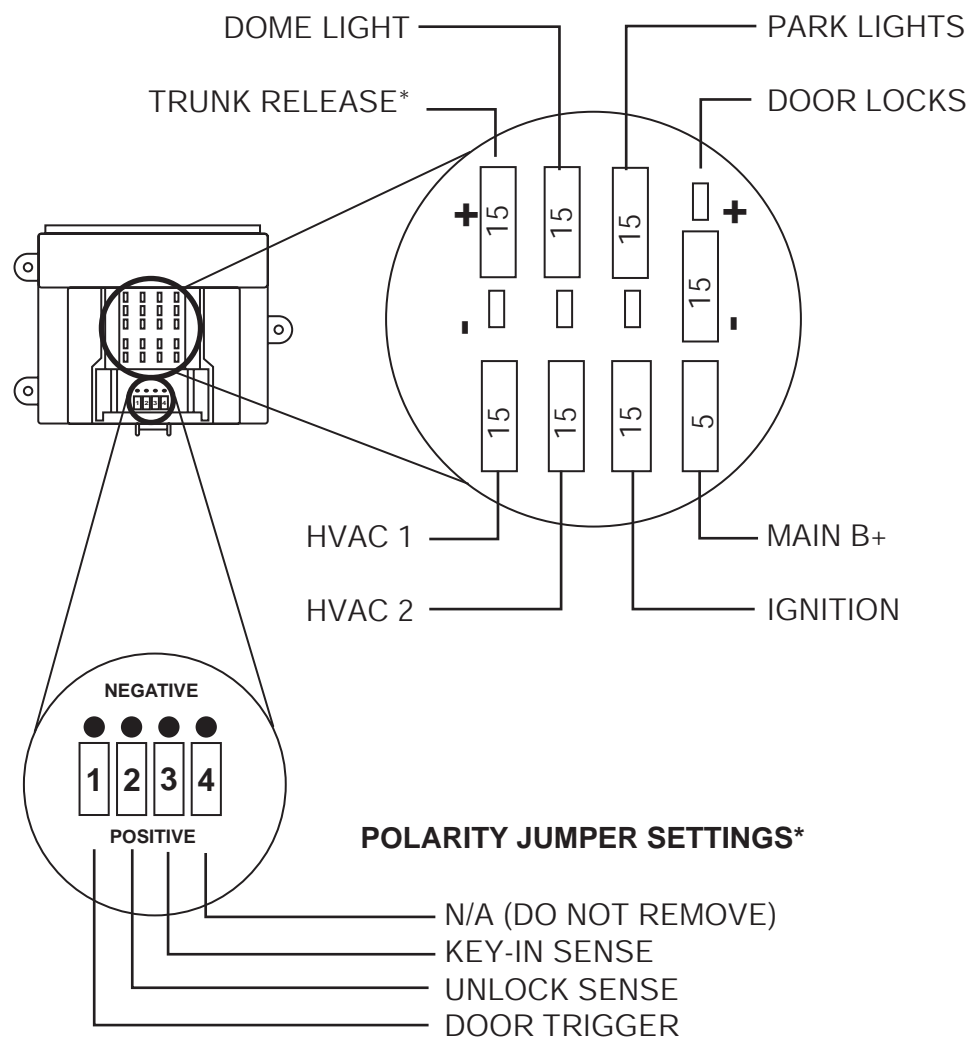

* See Polarity Jumper Section in Base Instructions for details

PARTS REQUIRED:

RKE/VSS/RMST Kit:

7L3Z-19G364-AA

Securilock (PATS) Interface:

PIK-4 (P/N: 7L2Z-19G365-AA - order separately)

RELAY REQUIREMENTS (P/N YL3Z-19G390-AA):

- 1- Driver's Door Priority Unlock (optional)
- 1- Headlights (optional)

FUNCTIONAL PROGRAMMING REQUIREMENTS

BANK	OPTION	DESCRIPTION	LED
1	1	LITE TOUCH ADJUSTMENT	note 1
1	2	FULL SHOCK ADJUSTMENT	note 1
1	4	DOOR AJAR INVERT	ON
1	5	UNLOCK SENSE INVERT	ON
1	6	KEY-IN SENSE INVERT	ON
2	1	STARTER INTERRUPT	OFF
2	8	DRIVER UNLOCK RELAY	note 2
3	1	DRIVER PRIORITY UNLOCK	note 2
4	1	TACHLESS MODE	ON

Note 1: Perform proper adjustments per the "Shock Sensor Setting" section of the Base instruction sheets.

Note 2: See the Optional Connections / Features page

MODULE MOUNTING LOCATION:

Left Side of Driver's Underdash

Vehicle (Year/Make/Model)	
'08 Focus	
Equipment or Trim level	System(s) applicable to:
ALL	RKE/VSS/RMST
Page	Revision Date
2 of 4	8/10/07

STEERING COLUMN HARNESS

	Color	Function
A-4	RED	Battery
B-2	RED	HVAC1 Feed
A-7	PINK	Ignition 1 Input/Output
B-4	ORANGE	HVAC 1 Output
A-8	VIOLET	Starter Output
B-8	BLACK/WHITE	Key-in-sense Input
A-21	BROWN/BLACK	Horn Relay Output
B-7	BROWN	Brake Input
A-1	WHITE	Parking Light Output
C-10	RED/WHITE	Headlight Output
C-11	BLUE/WHITE	Rear Defroster Output

MAKE THIS CONNECTION LAST!

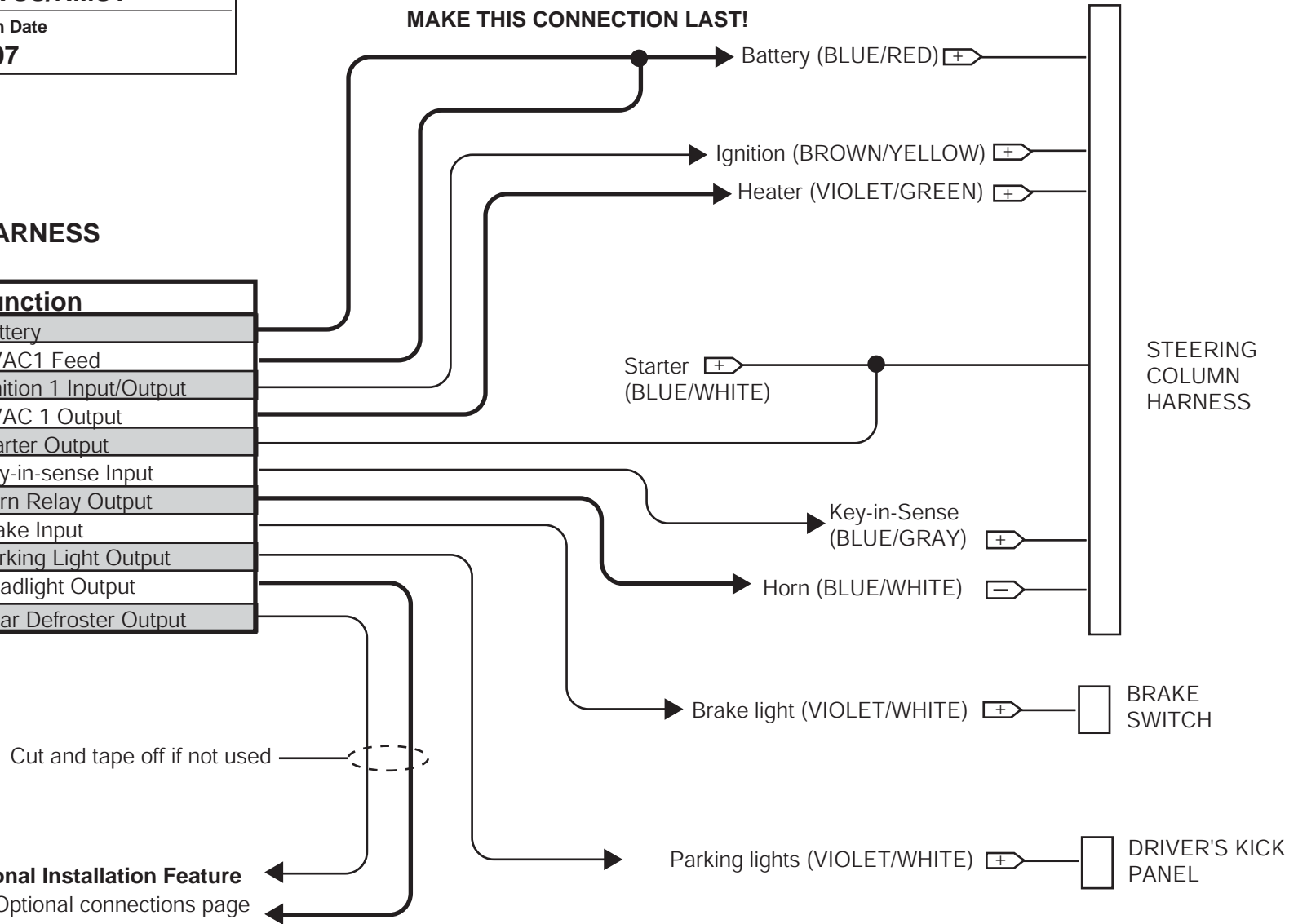

Vehicle (Year/Make/Model)	
'08 Focus	
Equipment or Trim level	System(s) applicable to:
ALL	RKE/VSS/RMST
Page	Revision Date
3 of 4	8/10/07

DRIVERS SIDE KICK PANEL HARNESS

	Color	Function
A-5	BLACK	Ground
A-20	GREEN/VIOLET	Door Ajar Input
A-3	BLACK/WHITE	Dome Light Output
A-2	BLUE	Door Lock Output
A-14	GREEN	Door Unlock Output
A-11	WHITE/BLUE	Arm Input
A-9	BROWN	Disarm Input
A-12	LT.GREEN	Unlock Switch Sense Input
A-13	TAN	Trunk Release Output
C-4	LT GREEN/BLACK	Factory Alarm Disarm Output
A-24	BLUE/GREEN	Driver Door Unlock Output

NOTE: Carefully test all circuits prior to making connections (multiple wires of same color).

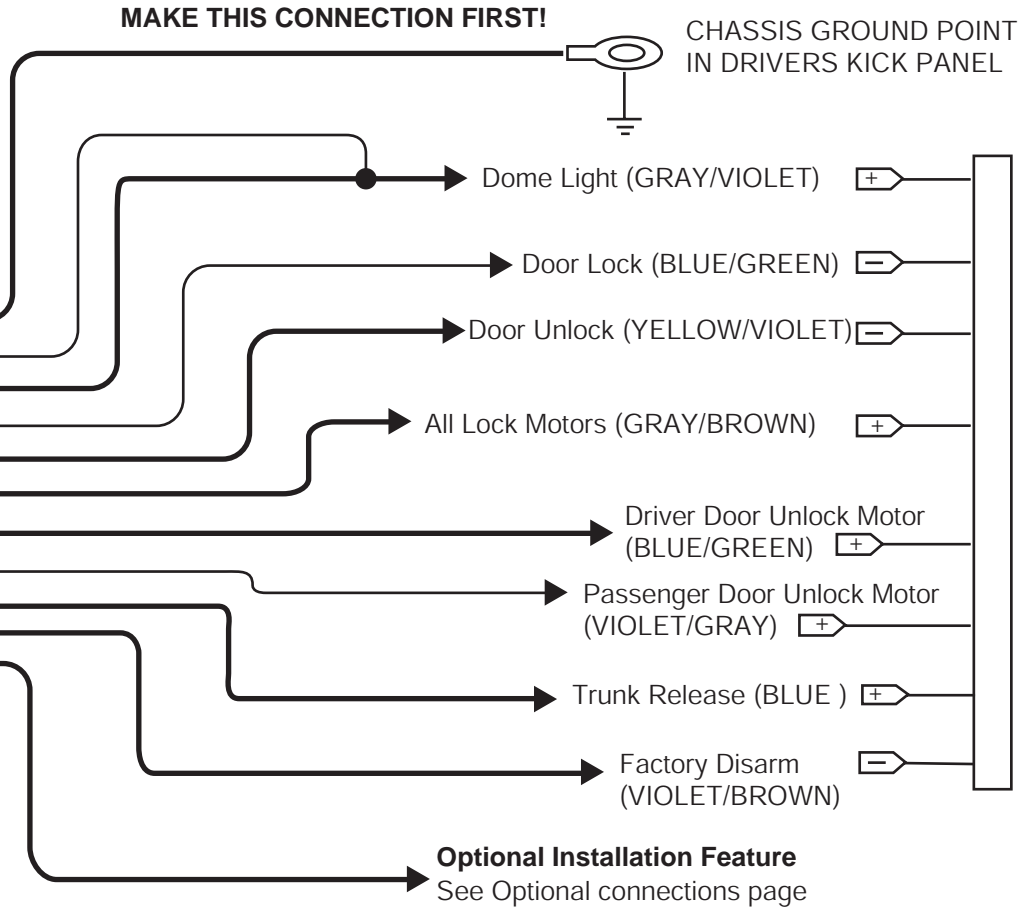

UNDERHOOD HARNESS

	Color	Function
A-19	GRAY	Hood Open Switch Input

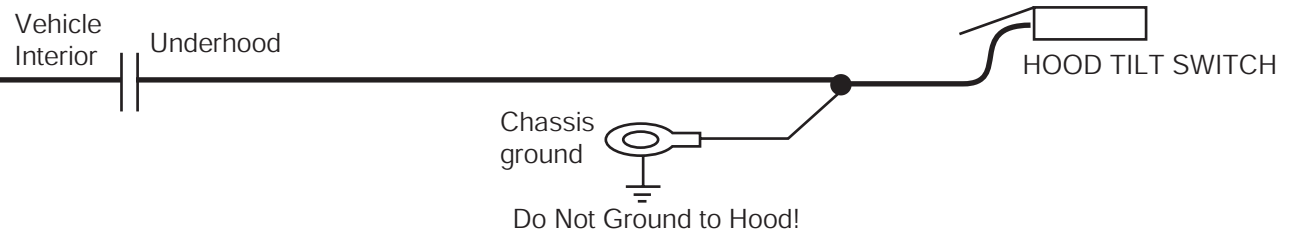

Vehicle (Year/Make/Model) '08 Focus	
Equipment or Trim level ALL	System(s) applicable to: RKE/VSS/RMST
Page 4 of 4	Revision Date 8/10/07

OPTIONAL CONNECTIONS / FEATURES

OPTION PROGRAMMING REQUIREMENTS

BANK	OPTION	DESCRIPTION	LED
3	1	DRIVER PRIORITY UNLOCK	ON

Relays shown are not supplied in kit. Relays are available by ordering Ford part number YL3Z-19G390-AA (Single) or YL3Z-19G390-BA (10 pack).

DRIVER'S DOOR PRIORITY UNLOCK

	Color	Function
A-24	BLUE/GREEN	Driver Door Unlock Output
A-9	BROWN	Disarm Input

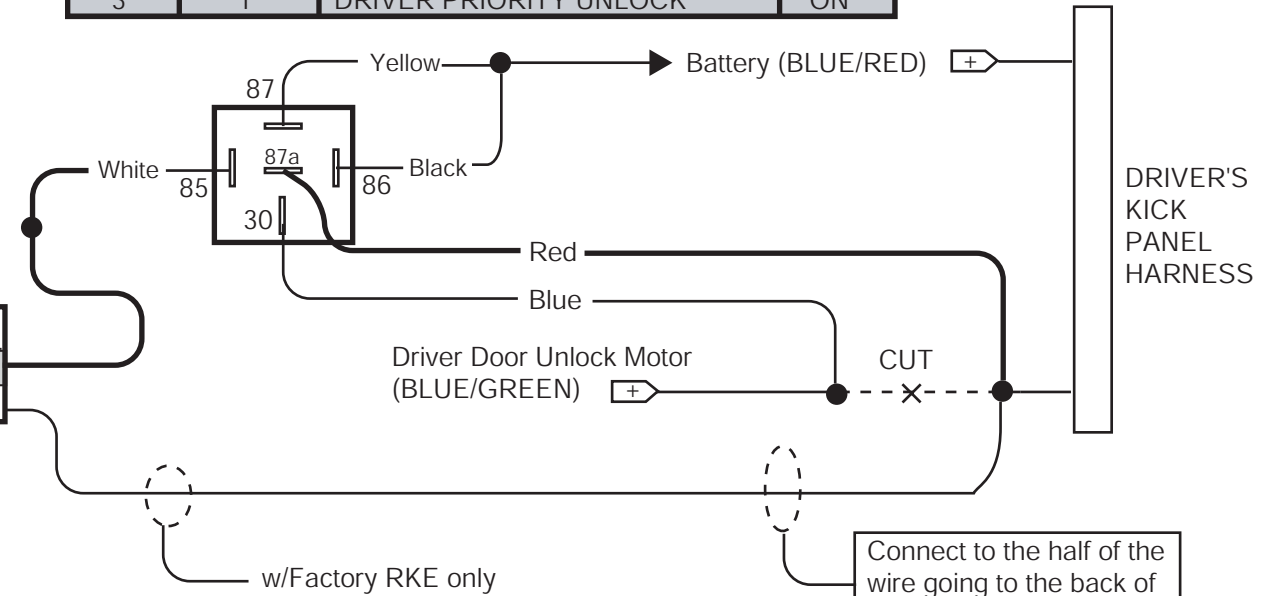

IMPORTANT!

The relay wire colors shown here, are the colors used on the FORD accessory relay kits listed above. Wire colors on other relays may be different!

Connect to the half of the wire going to the back of the vehicle

HEADLIGHT ILLUMINATION / REAR DEFROSTER

	Color	Function
C-11	BLUE/WHITE	Rear Defroster Output
C-10	RED/WHITE	Headlight Output

Relays shown are not supplied in kit. Relays are available by ordering Ford part number YL3Z-19G390-AA (Single) or YL3Z-19G390-BA (10 pack).

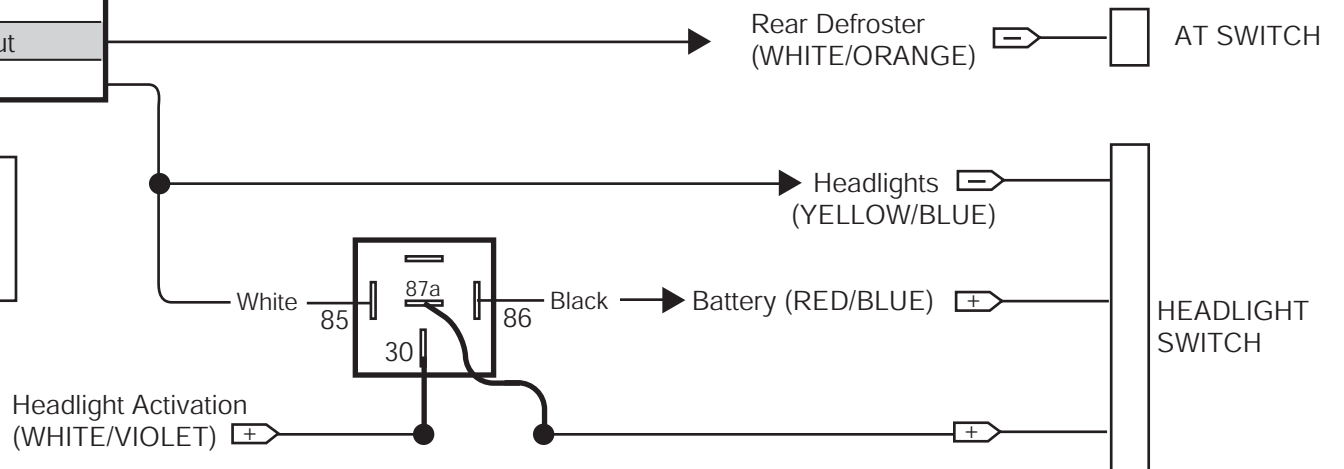

Vehicle (Year/Make/Model) '08 Focus	
Equipment or Trim level ALL	System(s) applicable to: RMST
Page 1 of 2	Revision Date 8/10/07

Module:
PC-14
7L2Z-19G367-AA

FUSE PLACEMENT CHART

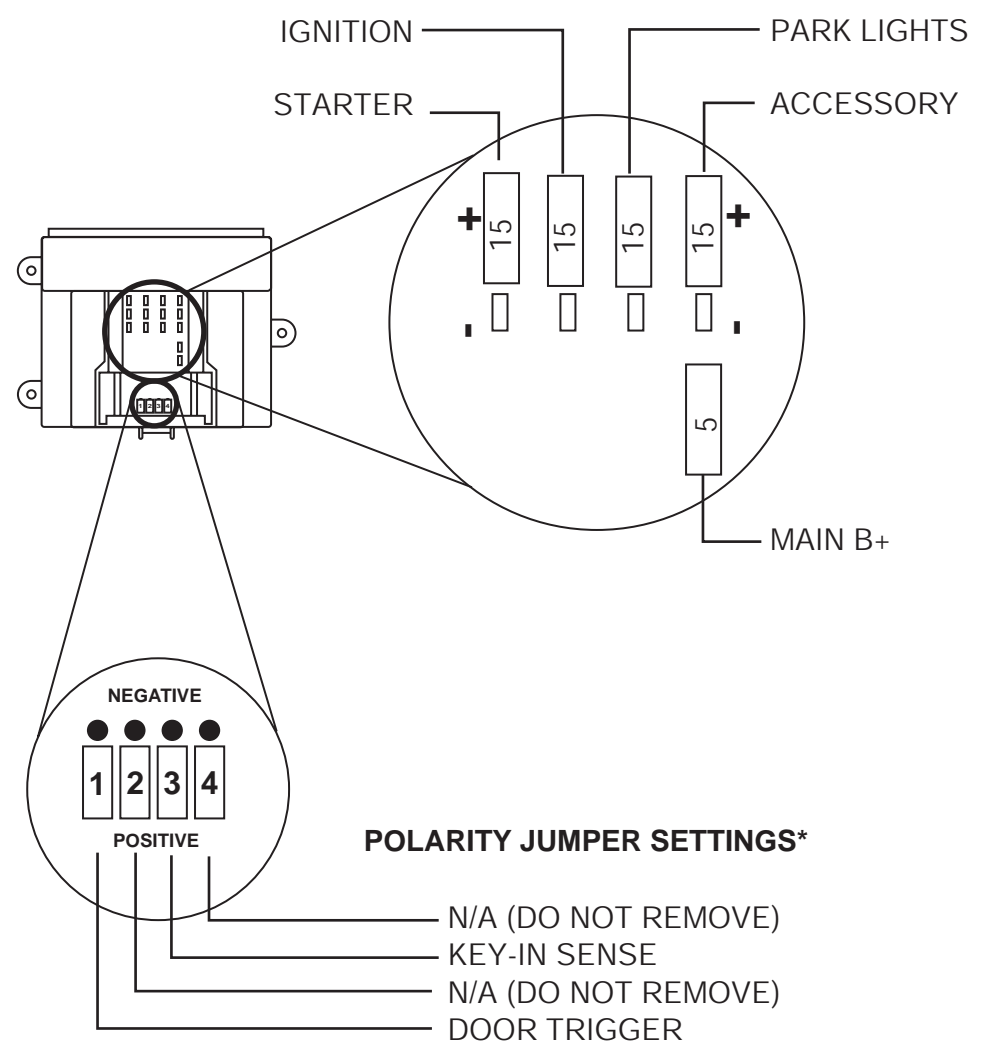

* See Polarity Jumper Section in Base Instructions for details

PARTS REQUIRED:

RMST Kit:
7L2Z-19G364-AA

Securilock (PATS) Interface:
PIK-4 (P/N: 7L2Z-19G365-AA - included)

RELAY REQUIREMENTS (P/N YL3Z-19G390-AA):

FUNCTIONAL PROGRAMMING REQUIREMENTS

BANK	OPTION	DESCRIPTION	LED
1	2	DOOR AJAR INVERT	ON
1	3	KEY-IN SENSE INVERT	ON
2	1	TACHLESS MODE	ON

MODULE MOUNTING LOCATION:
Left Side of Driver's Underdash

Vehicle (Year/Make/Model) '08 Focus	
Equipment or Trim level ALL	System(s) applicable to: RMST
Page 2 of 2	Revision Date 8/10/07

USE TYPE "A" CUSTOM WIRE HARNESS



STEERING COLUMN HARNESS

	Color	Function
A-3	PINK	Ignition Input/Output
A-2	ORANGE	HVAC Output
A-13	VIOLET	Starter Output
B-8	BLACK/WHITE	Key-in-sense Input
A-4	RED	Battery

	Color	Function
A-21	BROWN/BLACK	Horn Relay Output
A-1	WHITE	Parking Light Output

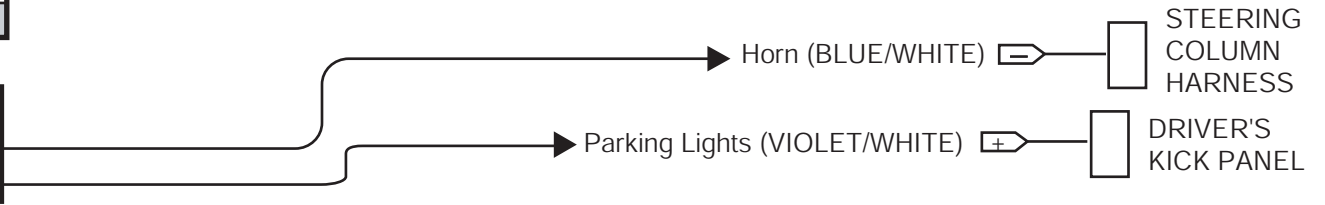

DRIVER'S KICK PANEL HARNESS

	Color	Function
A-5	BLACK	Ground
A-24	BLUE	Door Lock Output
B-7	BROWN	Brake Input
A-20	GREEN/VIOLET	Door Ajar Switch Input

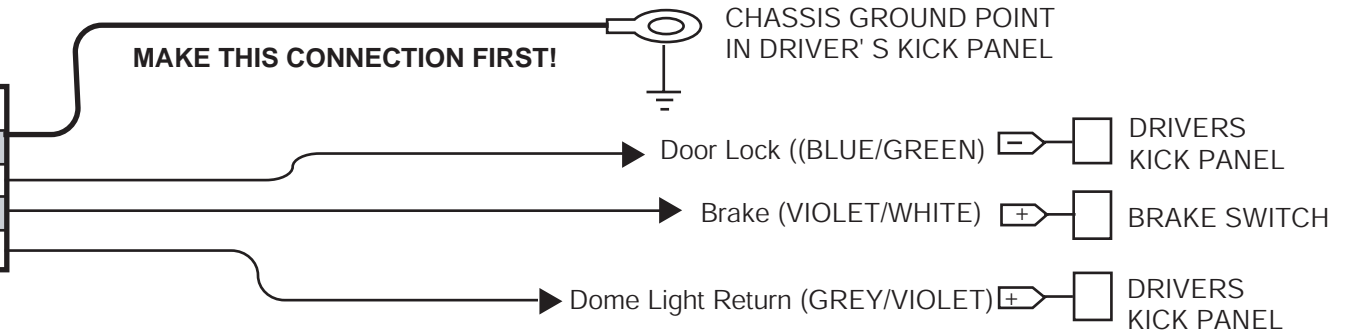

UNDER HOOD HARNESS

	Color	Function
A-19	GRAY	Hood Open Switch Input

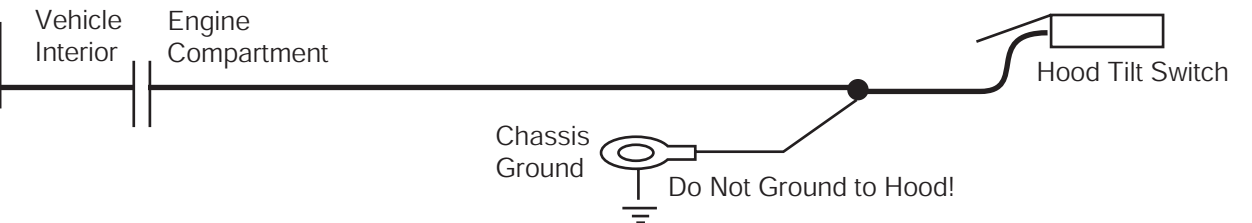

Vehicle (Year/Make/Model) '08 Focus	
Equipment or Trim level ALL	System(s) applicable to: VSS
Page 1 of 2	Revision Date 8/10/07

Module:
PC-14
7L2Z-19G367-AA

FUSE PLACEMENT CHART

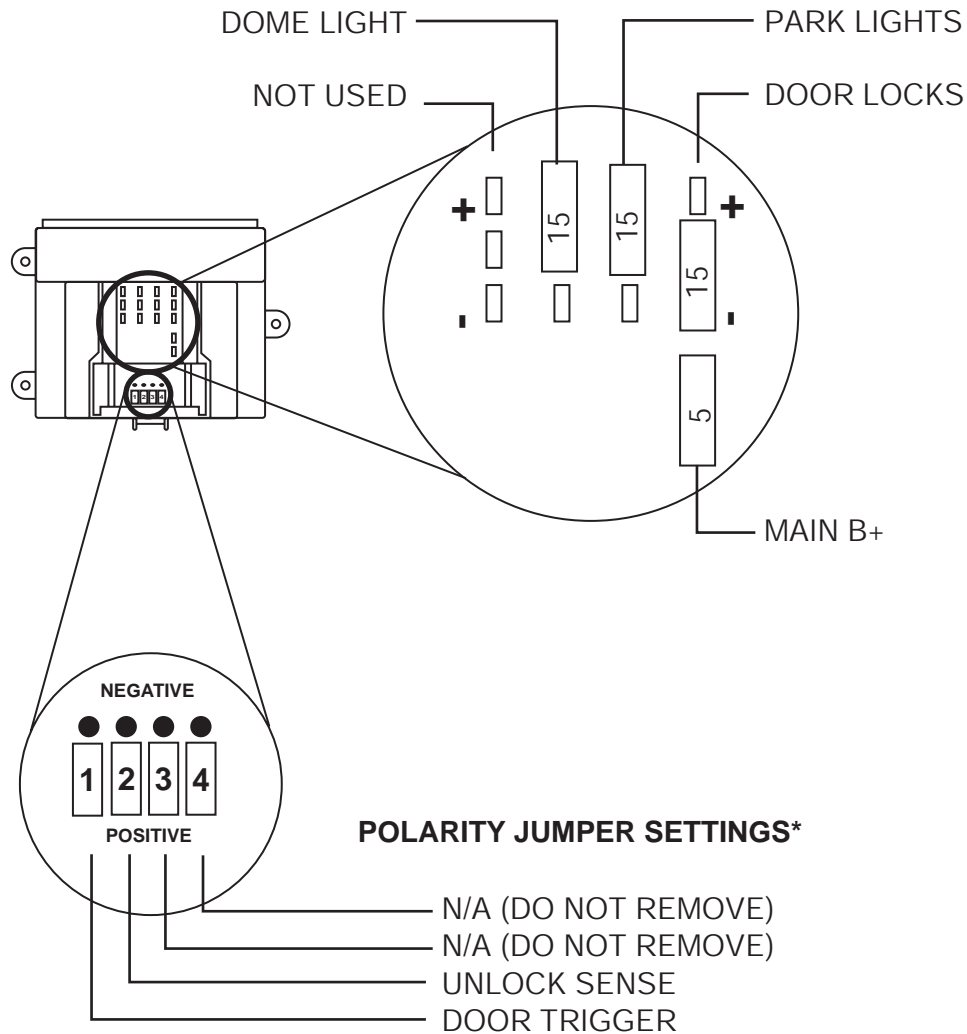

* See Polarity Jumper Section in Base Instructions for details

PARTS REQUIRED:

VSS Kit:
7L3Z-19A361-AA

FUNCTIONAL PROGRAMMING REQUIREMENTS

BANK	OPTION	DESCRIPTION	LED
1	1	LITE TOUCH ADJUSTMENT	note 1
1	2	FULL SHOCK ADJUSTMENT	note 1
1	4	DOOR AJAR INVERT	ON
1	5	UNLOCK SENSE INVERT	ON
2	1	STARTER INTERRUPT	ON

Note 1: Perform proper adjustments per the "Shock Sensor Setting" section of the Base instruction sheets.

MODULE MOUNTING LOCATION:

Left Side of Driver's Underdash

NOTE:

IF USING THIS SYSTEM IN LOT MODE, WIRE HARNESS P/N 2W7Z-19C757-BA WILL HAVE TO BE ORDERED TO ACCESS THE 'FACTORY DISARM OUTPUT" WIRE (LT.GREEN/BLACK).

Vehicle (Year/Make/Model)	
'08 Focus	
Equipment or Trim level	System(s) applicable to:
ALL	VSS
Page	Revision Date
2 of 2	8/10/07

DRIVERS SIDE KICK PANEL HARNESS

	Color	Function
A-5	BLACK	Ground
A-20	GREEN/VIOLET	Door Ajar Input
A-3	BLACK/WHITE	Dome Light Output
A-2	BLUE	Door Lock Output
A-14	GREEN	Door Unlock Output
C-4	LT GREEN/BLACK	Factory Alarm Disarm Output
A-11	WHITE/BLUE	Arm Input
A-9	BROWN	Disarm Input
A-12	LT.GREEN	Unlock Switch Sense Input

Connect only if system will be used in Lot Mode

MAKE THIS CONNECTION FIRST!

CHASSIS GROUND POINT IN DRIVERS KICK PANEL

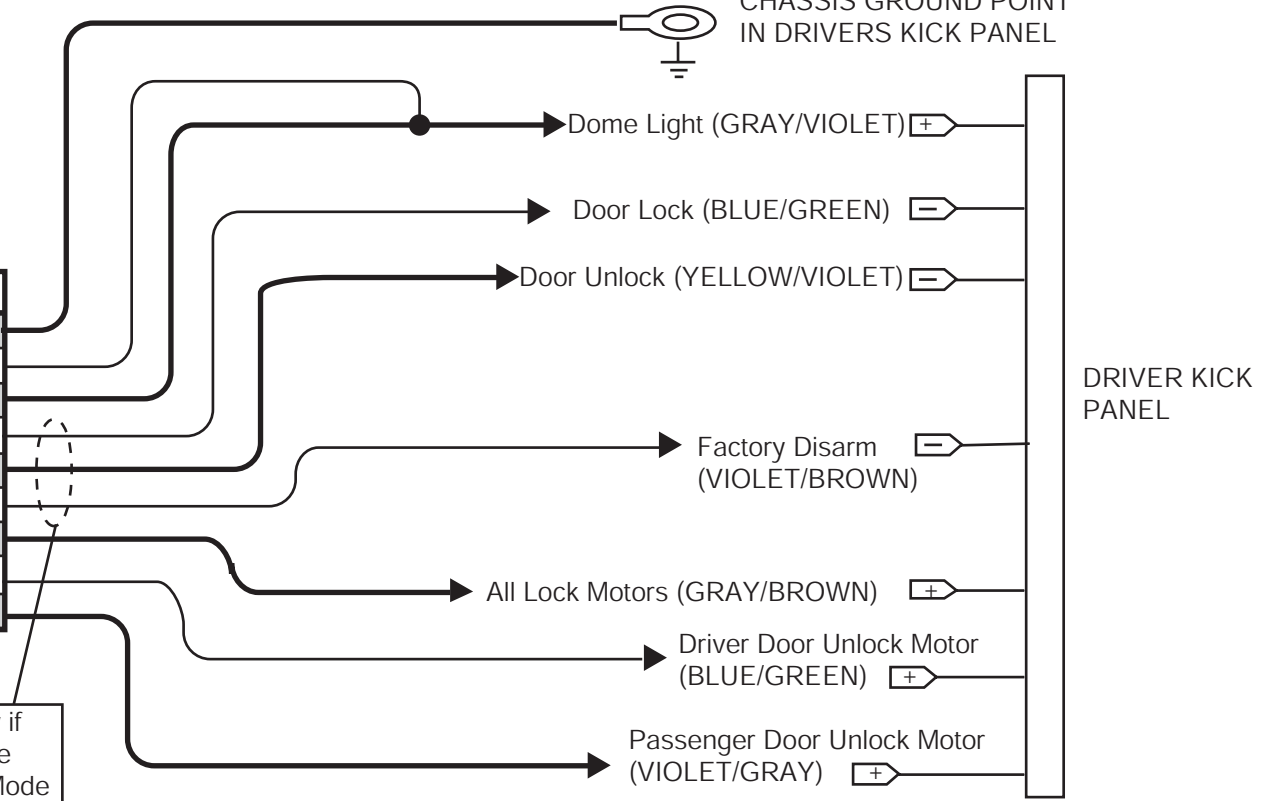

STEERING COLUMN HARNESS

	Color	Function
A-4	RED	Battery
A-7	PINK	Ignition 1 Input/Output
A-8	VIOLET	Starter Interrupt (Motor side)
A-6	VIOLET/RED	Starter Interrupt (Key side)
A-21	BROWN/BLACK	Horn Relay Output
A-1	WHITE	Parking Light Output

MAKE THIS CONNECTION LAST!

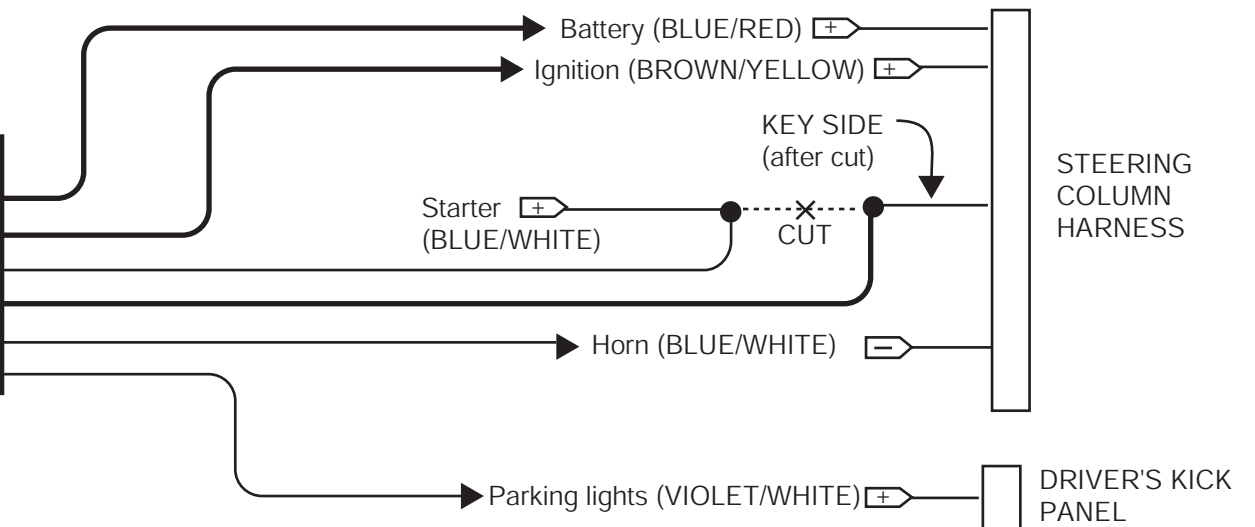

NOTE: Carefully test all circuits prior to making connections (multiple wires of same color).

Vehicle (Year/Make/Model) '08 Taurus/ Taurus X/ Sable	
Equipment or Trim level ALL	System(s) applicable to: RKE/VSS/RMST
Page 1 of 5	Revision Date 8/13/07

Module:
PC-34
7L3Z-19G367-AA

FUSE PLACEMENT CHART

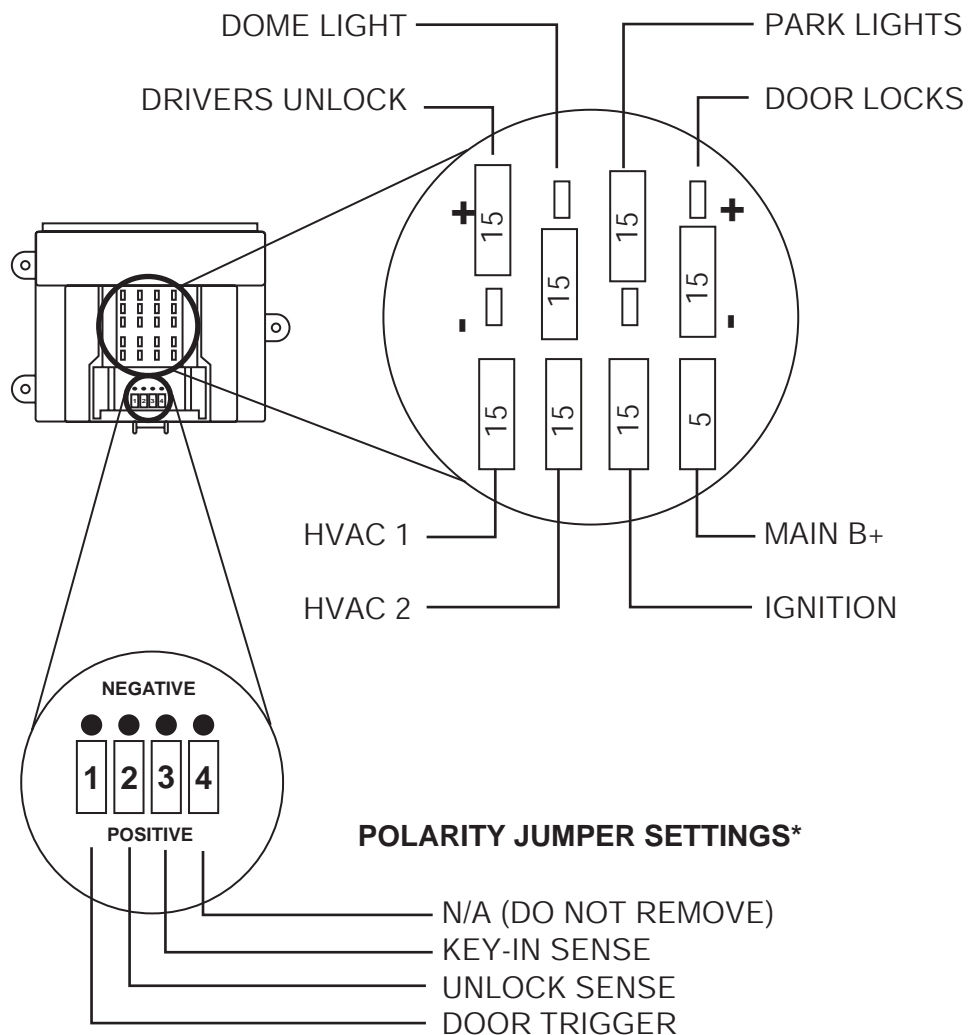

* See Polarity Jumper Section in Base Instructions for details

PARTS REQUIRED:

RKE/VSS/RMST Kit:

7L3Z-19G364-AA

Securilock (PATS) Interface:

PIK-4 (P/N: 7L2Z-19G365-AA - order separately)

RELAY REQUIREMENTS (P/N YL3Z-19G390-AA):

1- Liftglass Release (optional)

FUNCTIONAL PROGRAMMING REQUIREMENTS

BANK	OPTION	DESCRIPTION	LED
1	1	LITE TOUCH ADJUSTMENT	note 1
1	2	FULL SHOCK ADJUSTMENT	note 1
1	4	DOOR AJAR INVERT	ON
1	5	UNLOCK SENSE INVERT	ON
1	6	KEY-IN SENSE INVERT	ON
2	1	STARTER INTERRUPT	OFF
2	8	DRIVER UNLOCK RELAY	note 2
3	1	DRIVER PRIORITY UNLOCK	note 2
4	1	TACHLESS MODE	ON

Note 1: Perform proper adjustments per the "Shock Sensor Setting" section of the Base instruction sheets.

Note 2: See the Optional Connections / Features page

MODULE MOUNTING LOCATION:

Left Side of Driver's Underdash

Vehicle (Year/Make/Model)	
'08 Taurus/ Taurus X/ Sable	
Equipment or Trim level	System(s) applicable to:
ALL	RKE/VSS/RMST
Page	Revision Date
2 of 5	8/13/07

STEERING COLUMN HARNESS

	Color	Function
A-4	RED	Battery
B-2	RED	HVAC1 Battery Feed
A-7	PINK	Ignition 1 Input/Output
B-4	ORANGE	HVAC1 Output
B-8	BLACK/WHITE	Key-in-sense Input
A-8	VIOLET	Starter Interrupt Motor Side
A-21	BROWN/BLACK	Horn Relay Output
C-11	BLUE/WHITE	Defrost
C-11	BLUE/WHITE	Defrost

MAKE THIS CONNECTION LAST!

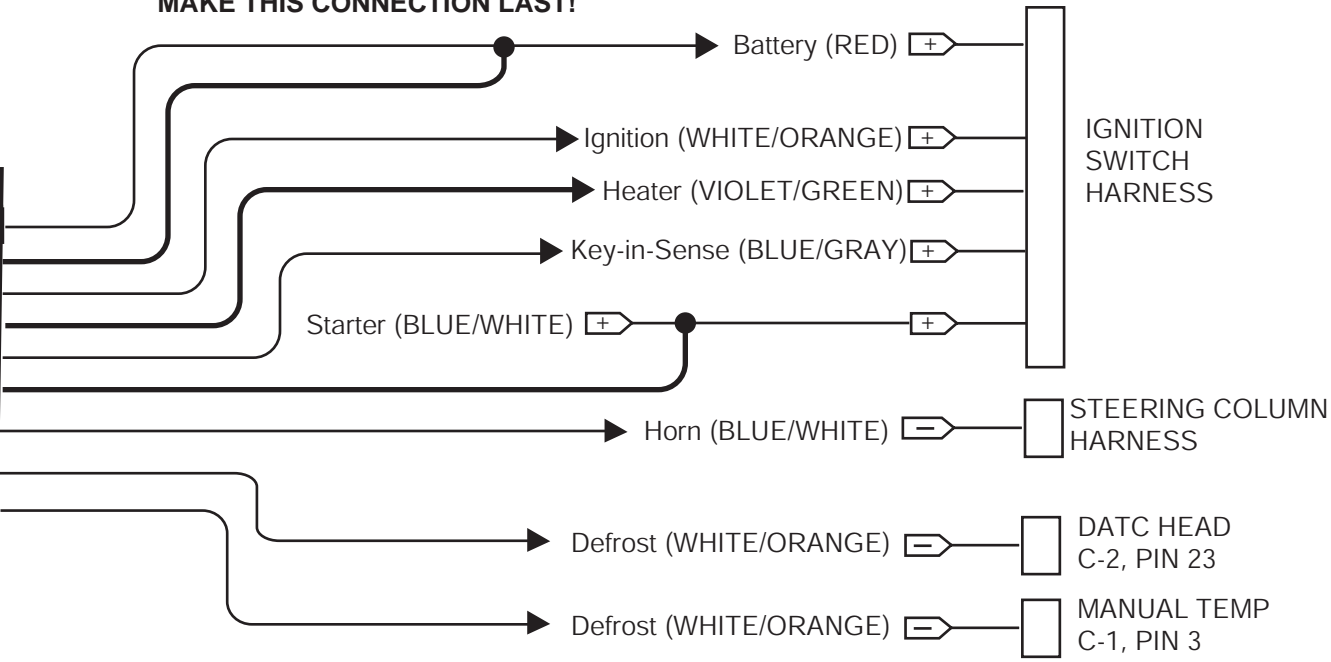

UNDERHOOD HARNESS

	Color	Function
A-19	GRAY	Hood Open Switch Input

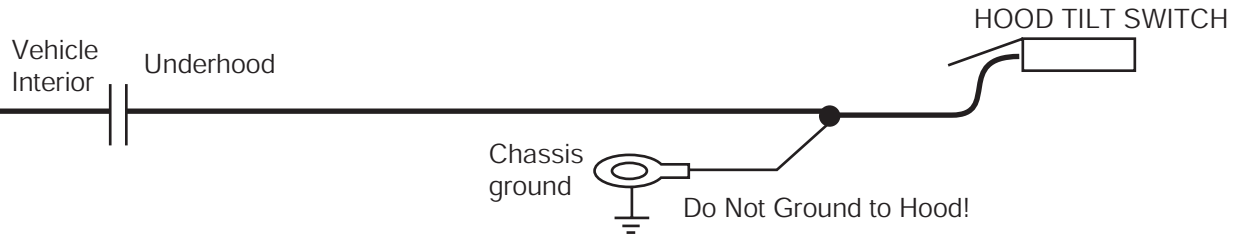

Vehicle (Year/Make/Model) '08 Taurus/ Taurus X/ Sable	
Equipment or Trim level ALL	System(s) applicable to: RKE/VSS/RMST
Page 3 of 5	Revision Date 8/13/07

DRIVER'S SIDE KICK PANEL HARNESS

	Color	Function
A-5	BLACK	Ground

KICK PANEL HARNESS

	Color	Function
B-7	BROWN	Brake Input
A-20	GREEN/VIOLET	Door Ajar Switch Input
A-11	WHITE/BLUE	Arm Input
A-2	BLUE	Door Lock Output
A-14	GREEN	Door Unlock Output
A-9	BROWN	Disarm Input
C-4	GREEN/VIOLET	Factory Alarm Disarm
A-12	LT. GREEN	Unlock Switch Sense Input
A-24	BLUE/GREEN	Driver Door Unlock Output

MAKE THIS CONNECTION FIRST!

See "SJB Layout" page for connector locations.

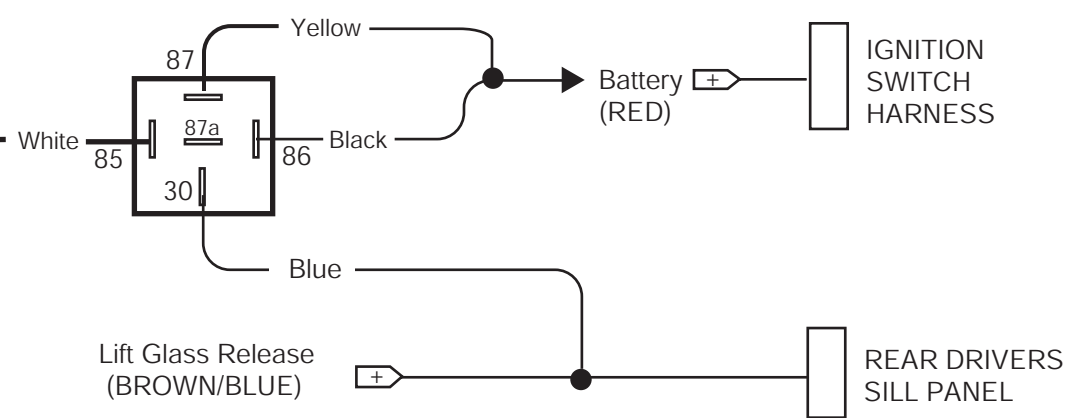
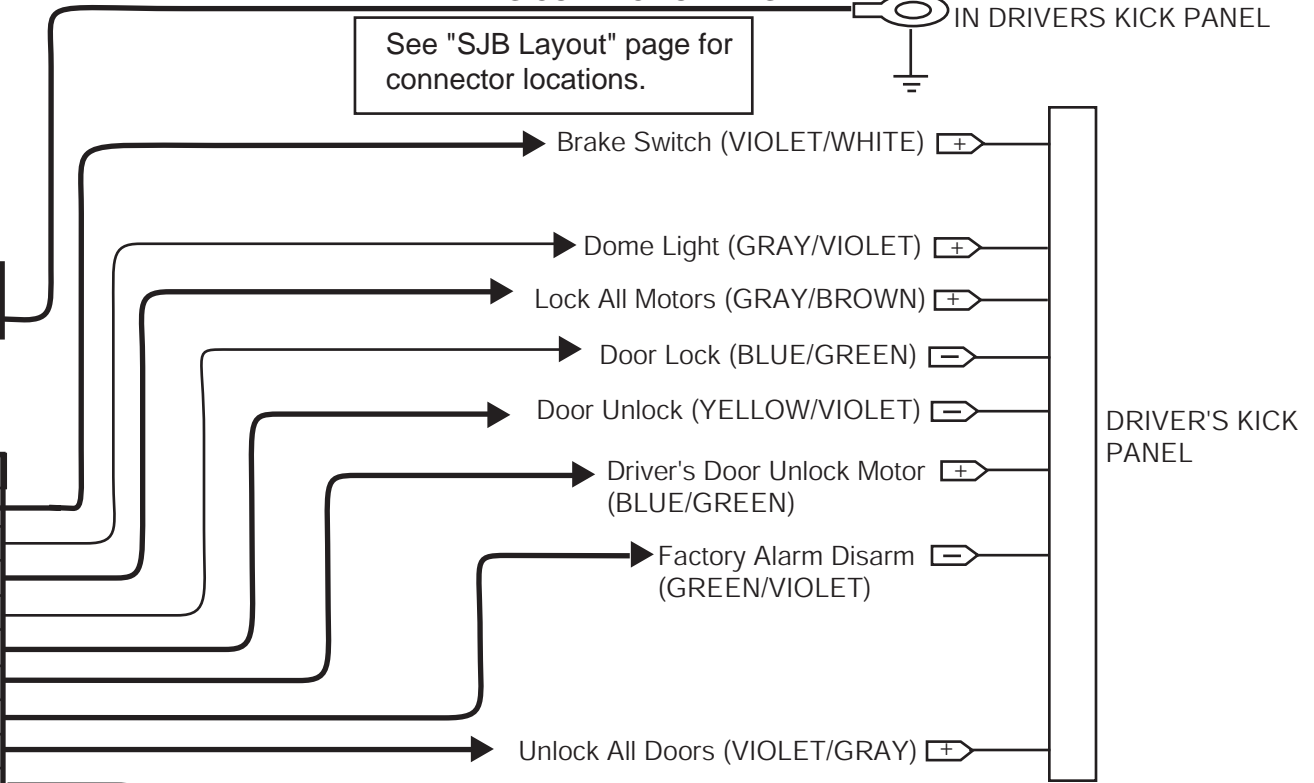
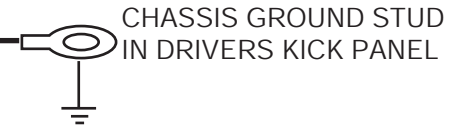

Vehicle (Year/Make/Model) '08 Taurus/ Taurus X/ Sable	
Equipment or Trim level ALL	System(s) applicable to: RKE/VSS/RMST
Page 4 of 5	Revision Date 8/13/07

HEADLAMP SWITCH HARNESS

	Color	Function
A-1	WHITE	Parking Light Output

Parking Lights On
(VIOLET/WHITE)



SJB
J5 CONNECTOR
PIN 6

DOMELIGHT HARNESS

	Color	Function
A-3	BLACK/WHITE	Dome Light Output

Dome Light (GREEN/BLUE)



DOMELAMP
SWITCH

TRUNK RELEASE HARNESS

	Color	Function
A-24	BLUE/GREEN	Trunk Release

OR

Taurus/Sable

Decklid Release Switch
(BROWN)



INSTRUMENT
PANEL

Taurus X

Power Liftgate Switch
(GRAY/YELLOW)



Vehicle (Year/Make/Model)	
'08 Taurus/ Taurus X/ Sable	
Equipment or Trim level	System(s) applicable to:
ALL	RKE/VSS/RMST
Page	Revision Date
5 of 5	8/13/07

OPTIONAL CONNECTIONS / FEATURES

OPTION PROGRAMMING REQUIREMENTS

BANK	OPTION	DESCRIPTION	LED
2	8	DRIVER UNLOCK RELAY	ON
3	1	DRIVER PRIORITY UNLOCK	ON

DRIVER'S DOOR PRIORITY UNLOCK

	Color	Function
C-9	TAN/RED	Driver Door Unlock Switch
A-13	TAN	Driver Door Unlock Motor
A-9	BROWN	Disarm Input

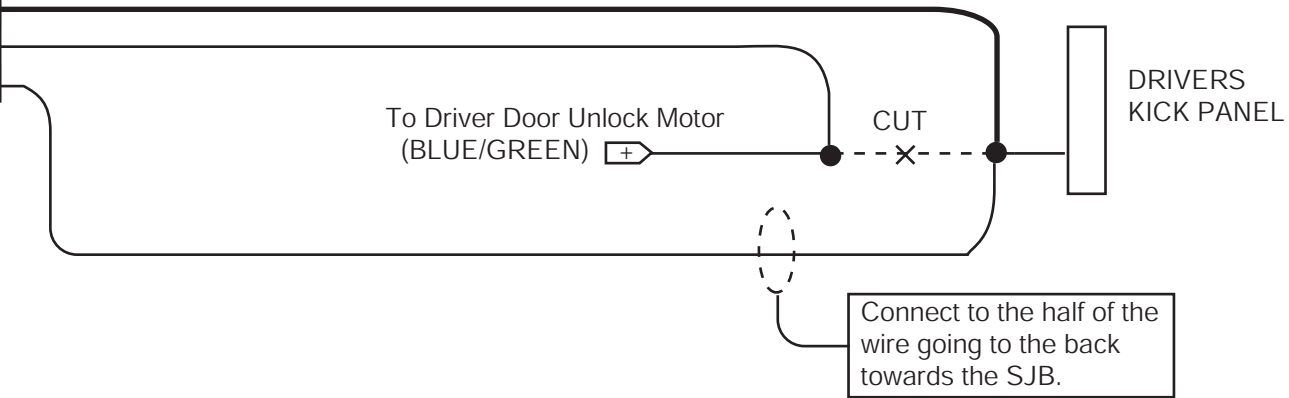

HEADLIGHTS/REAR DEFROSTER

	Color	Function
C-10	RED/WHITE	Headlight Output



Vehicle (Year/Make/Model) '08 Taurus/ Taurus X/ Sable	
Equipment or Trim level ALL	System(s) applicable to: RMST
Page 1 of 2	Revision Date 8/13/07

Module:
PC-14
7L2Z-19G367-AA

FUSE PLACEMENT CHART

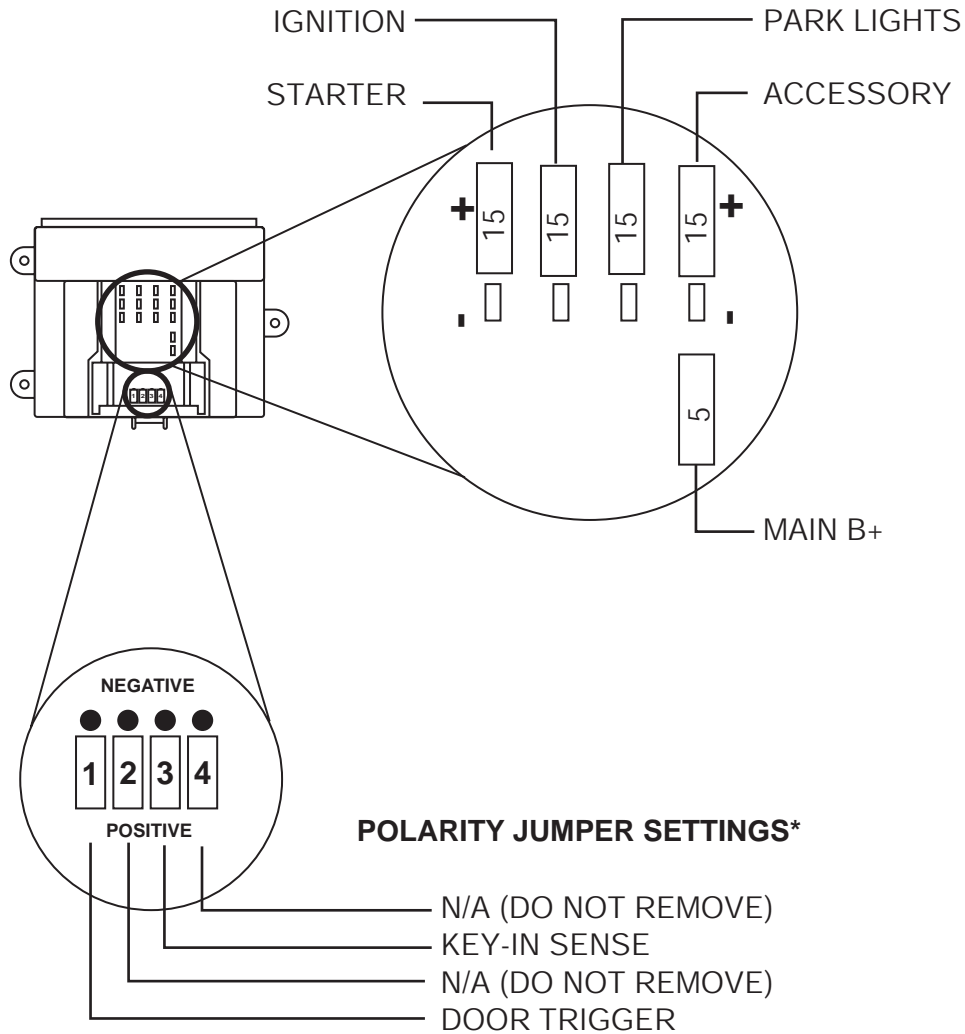

POLARITY JUMPER SETTINGS*

* See Polarity Jumper Section in Base Instructions for details

PARTS REQUIRED:

RMST Kit:
7L2Z-19G364-AA

Securilock (PATS) Interface:
PIK-4 (P/N: 7L2Z-19G365-AA - included)

FUNCTIONAL PROGRAMMING REQUIREMENTS

BANK	OPTION	DESCRIPTION	LED
1	2	DOOR AJAR INVERT	ON
1	3	KEY-IN SENSE INVERT	ON
2	1	TACHLESS MODE	ON

MODULE MOUNTING LOCATION:

Left Side of Driver's Underdash

Vehicle (Year/Make/Model)	
'08 Taurus/ Taurus X/ Sable	
Equipment or Trim level	System(s) applicable to:
ALL	RMST
Page	Revision Date
2 of 2	8/13/07

USE TYPE "A" CUSTOM WIRE HARNESS



STEERING COLUMN HARNESS

	Color	Function
A-3	PINK	Ignition Input/Output
A-2	ORANGE	HVAC Output
A-13	VIOLET	Starter Output
B-8	BLACK/WHITE	Key-in-sense Input
A-4	RED	Battery

	Color	Function
A-21	BROWN/BLACK	Horn Relay Output

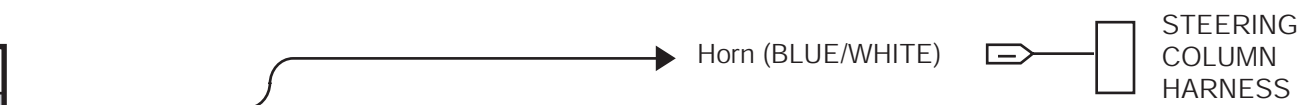

DRIVER'S KICK PANEL HARNESS

	Color	Function
A-5	BLACK	Ground
A-24	BLUE	Door Lock Output
B-7	BROWN	Brake Input
A-20	GREEN/VIOLET	Door Ajar Switch Input

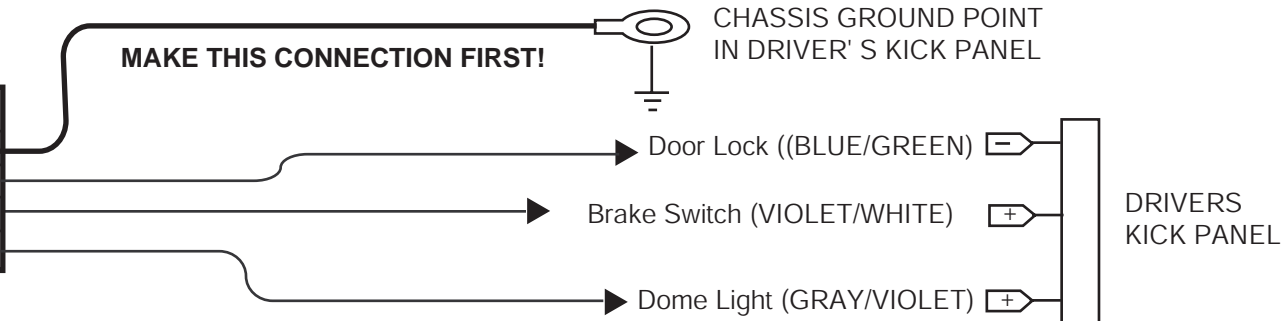

HEADLAMP SWITCH HARNESS

	Color	Function
A-1	WHITE	Parking Light Output

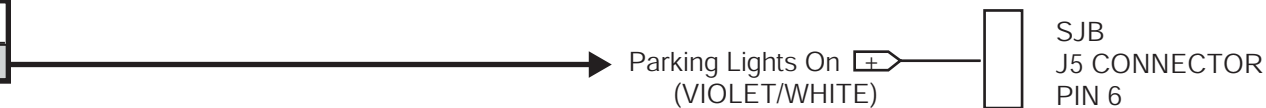

UNDER HOOD HARNESS

	Color	Function
A-19	GRAY	Hood Open Switch Input

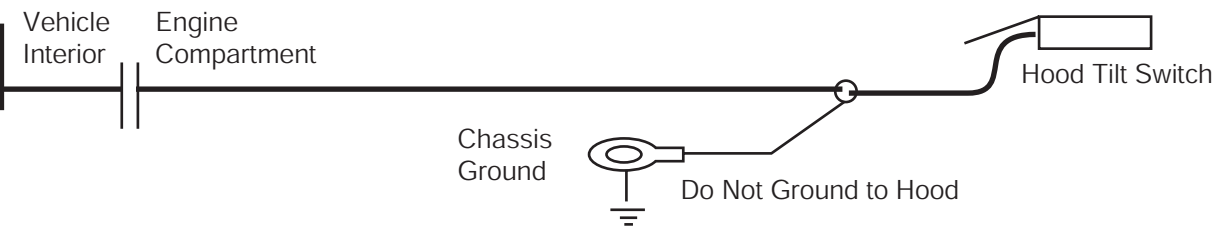

Vehicle (Year/Make/Model) '08 Taurus/ Taurus X/ Sable	
Equipment or Trim level ALL	System(s) applicable to: VSS
Page 1 of 2	Revision Date 8/13/07

Module:
PC-14
7L2Z-19G367-AA

FUSE PLACEMENT CHART

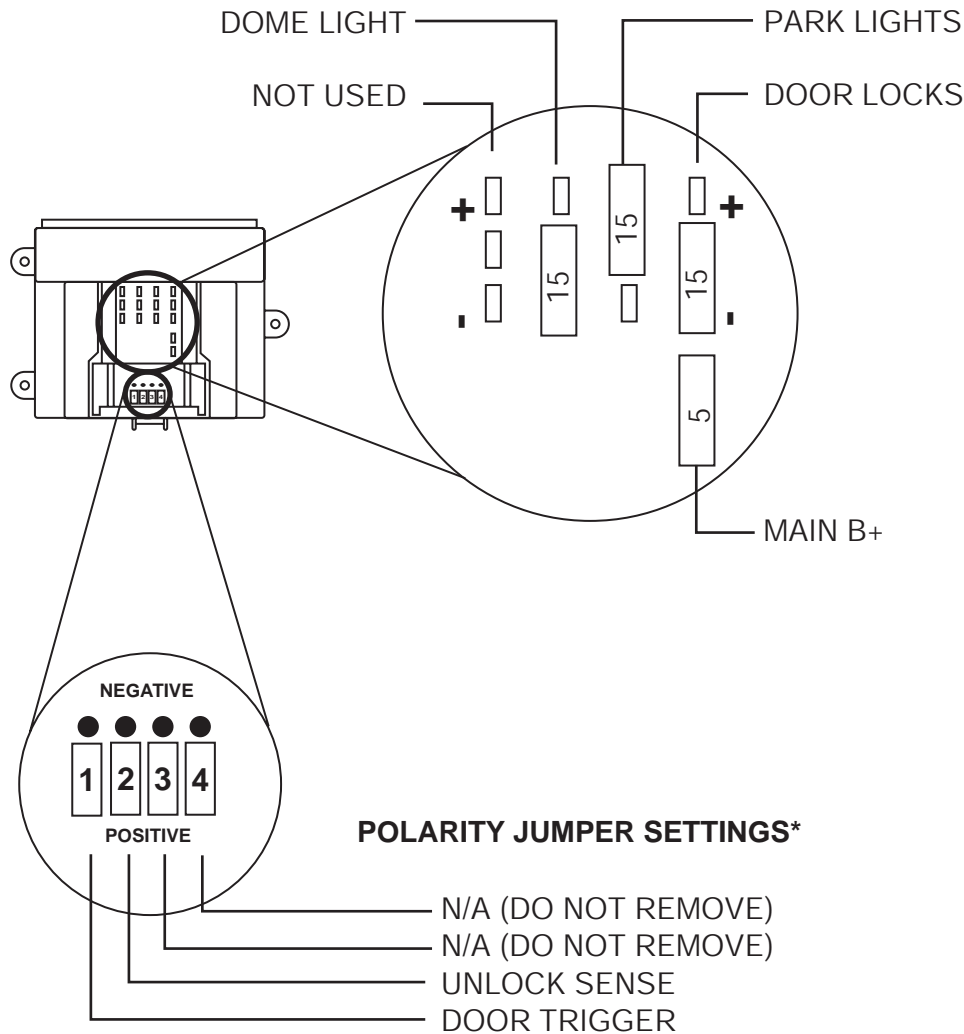

* See Polarity Jumper Section in Base Instructions for details

PARTS REQUIRED:

VSS Kit:
7L3Z-19A361-AA

FUNCTIONAL PROGRAMMING REQUIREMENTS

BANK	OPTION	DESCRIPTION	LED
1	1	LITE TOUCH ADJUSTMENT	note 1
1	2	FULL SHOCK ADJUSTMENT	note 1
1	3	DOOR AJAR INVERT	ON
1	4	UNLOCK SENSE INVERT	ON
2	1	STARTER INTERRUPT	ON

Note 1: Perform proper adjustments per the "Shock Sensor Setting" section of the Base instruction sheets.

MODULE MOUNTING LOCATION:

Left Side of Driver's Underdash

NOTE:

IF USING THIS SYSTEM IN LOT MODE, WIRE HARNESS P/N 2W7Z-19C757-BA WILL HAVE TO BE ORDERED TO ACCESS THE 'FACTORY DISARM OUTPUT" WIRE (LT.GREEN/BLACK).

Vehicle (Year/Make/Model)	
'08 Taurus/ Taurus X/ Sable	
Equipment or Trim level	System(s) applicable to:
w/ factory RKE	VSS
Page	Revision Date
2 of 2	8/13/07

STEERING COLUMN HARNESS

	Color	Function
A-4	RED	Battery
A-7	PINK	Ignition 1 Input/Output
A-8	VIOLET	Starter Interrupt Motor Side
A-6	VIOLET/RED	Starter Interrupt Key Side
A-21	BROWN/BLACK	Horn Relay Output

MAKE THIS CONNECTION LAST!

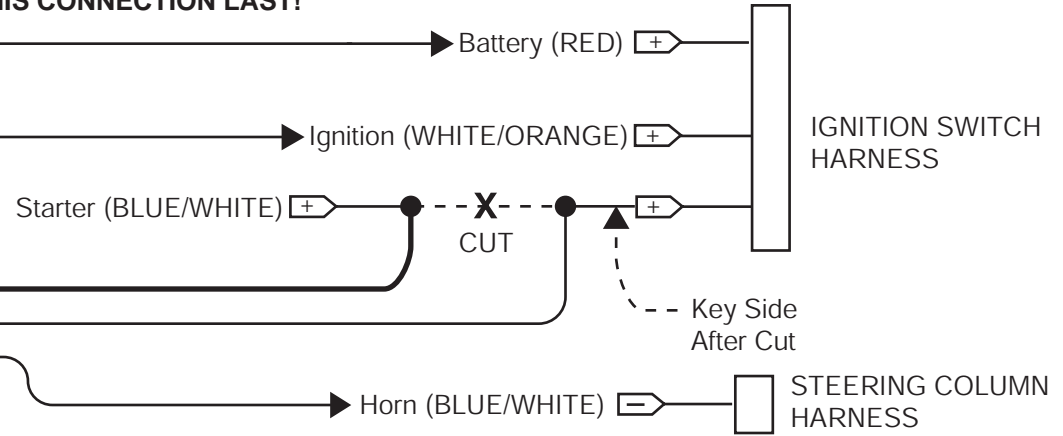

DRIVER'S SIDE KICK PANEL HARNESS

	Color	Function
A-5	BLACK	Ground

MAKE THIS CONNECTION FIRST!



KICK PANEL HARNESS

	Color	Function
A-20	GREEN/VIOLET	Door Ajar Switch Input
A-11	WHITE/BLUE	Arm Input
A-2	BLUE	Door Lock Output
A-14	GREEN	Door Unlock Output
C-4	GREEN/VIOLET	Factory Alarm Disarm
A-9	BROWN	Disarm Input
A-12	LT. GREEN	Unlock Switch Sense Input

Connect only if system will be used in Lot Mode

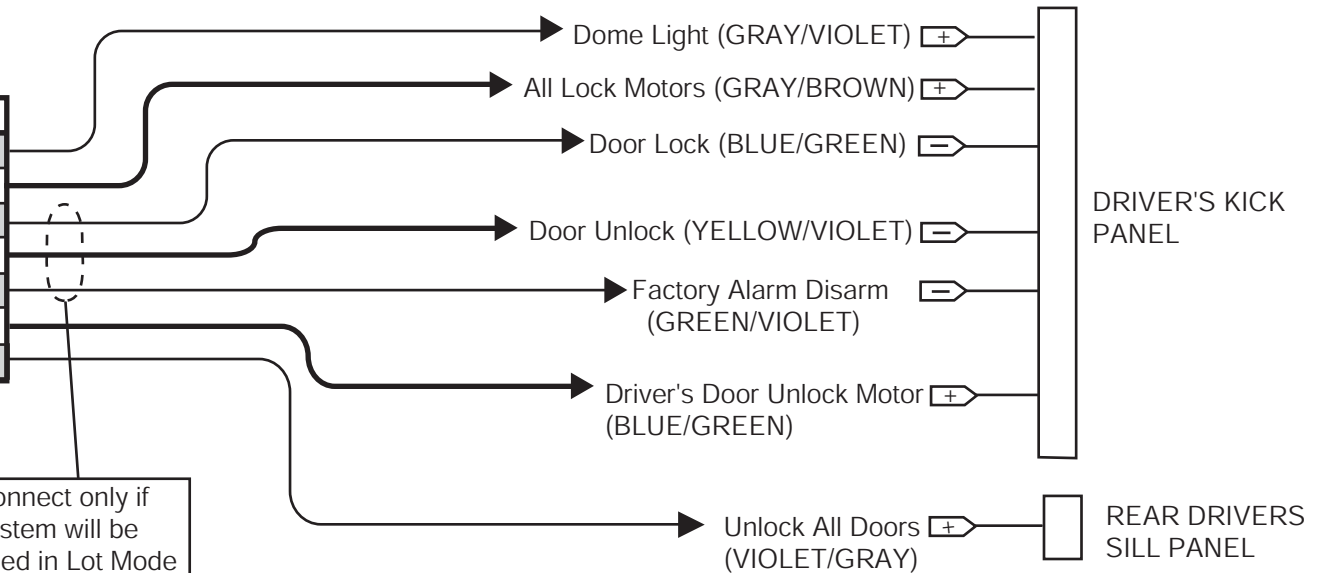

HEADLAMP SWITCH HARNESS

	Color	Function
A-1	WHITE	Parking Light Output



Vehicle (Year/Make/Model)	
'08 Taurus/ Taurus X/ Sable	
Equipment or Trim level	System(s) applicable to:
ALL	ALL
Page	Revision Date
1 of 1	8/13/07

