

IN-VEHICLE REPAIR

Engine Lubrication Components — Exploded View

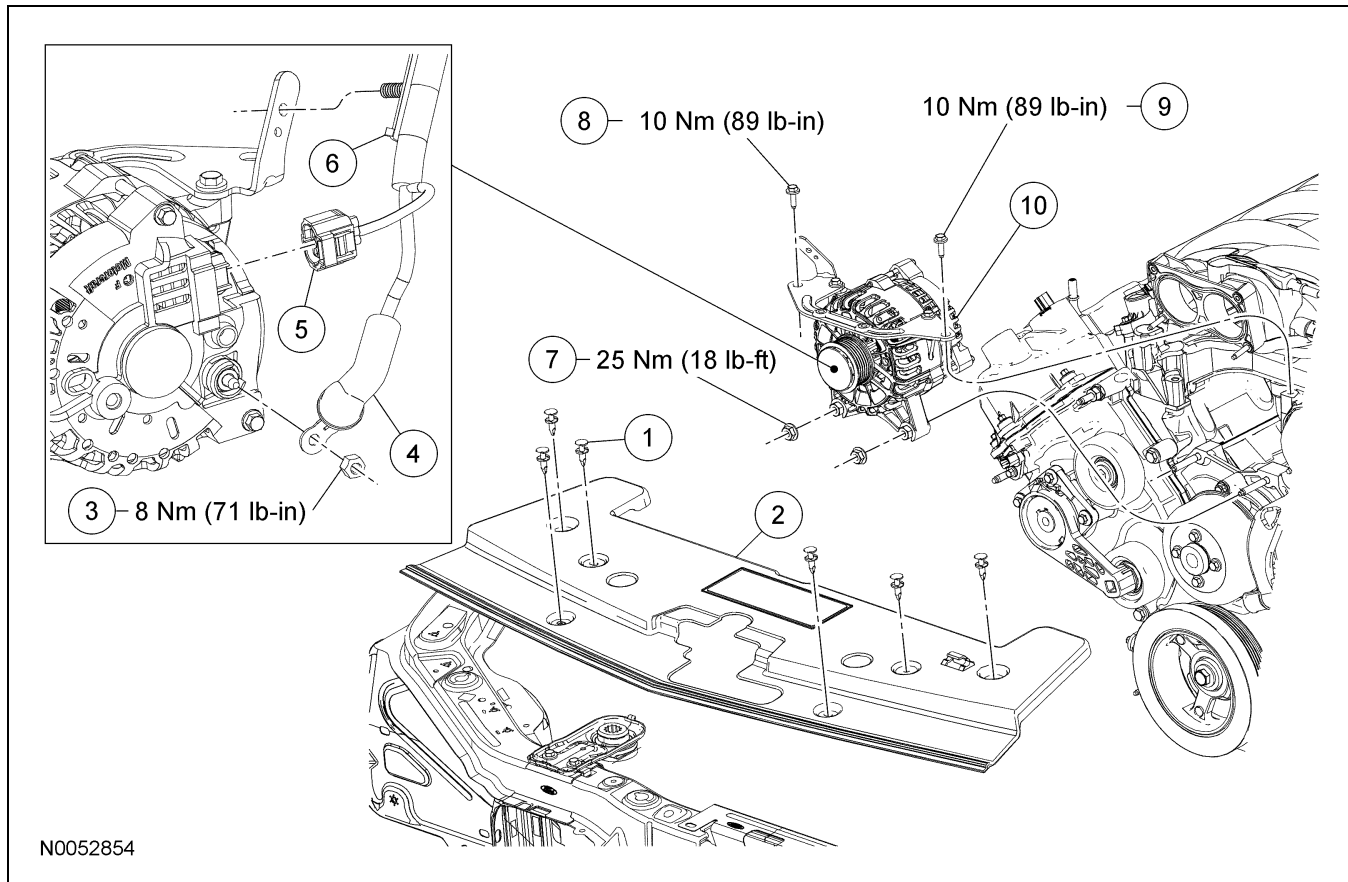

Item	Part Number	Description
1	—	Pin-type retainer
2	8C291	Radiator sight shield
3	W705790	B+ terminal nut
4	—	B+ terminal cover (part of 14305)
5	14A4644	Generator electrical connector (part of 14305)

(Continued)

Item	Part Number	Description
6	—	Wiring harness pin-type retainer (part of 14305)
7	N804758	Generator nut (2 required)
8	N807309	Generator bracket bolt
9	W704682	Generator bracket bolt
10	10300	Generator

IN-VEHICLE REPAIR (Continued)

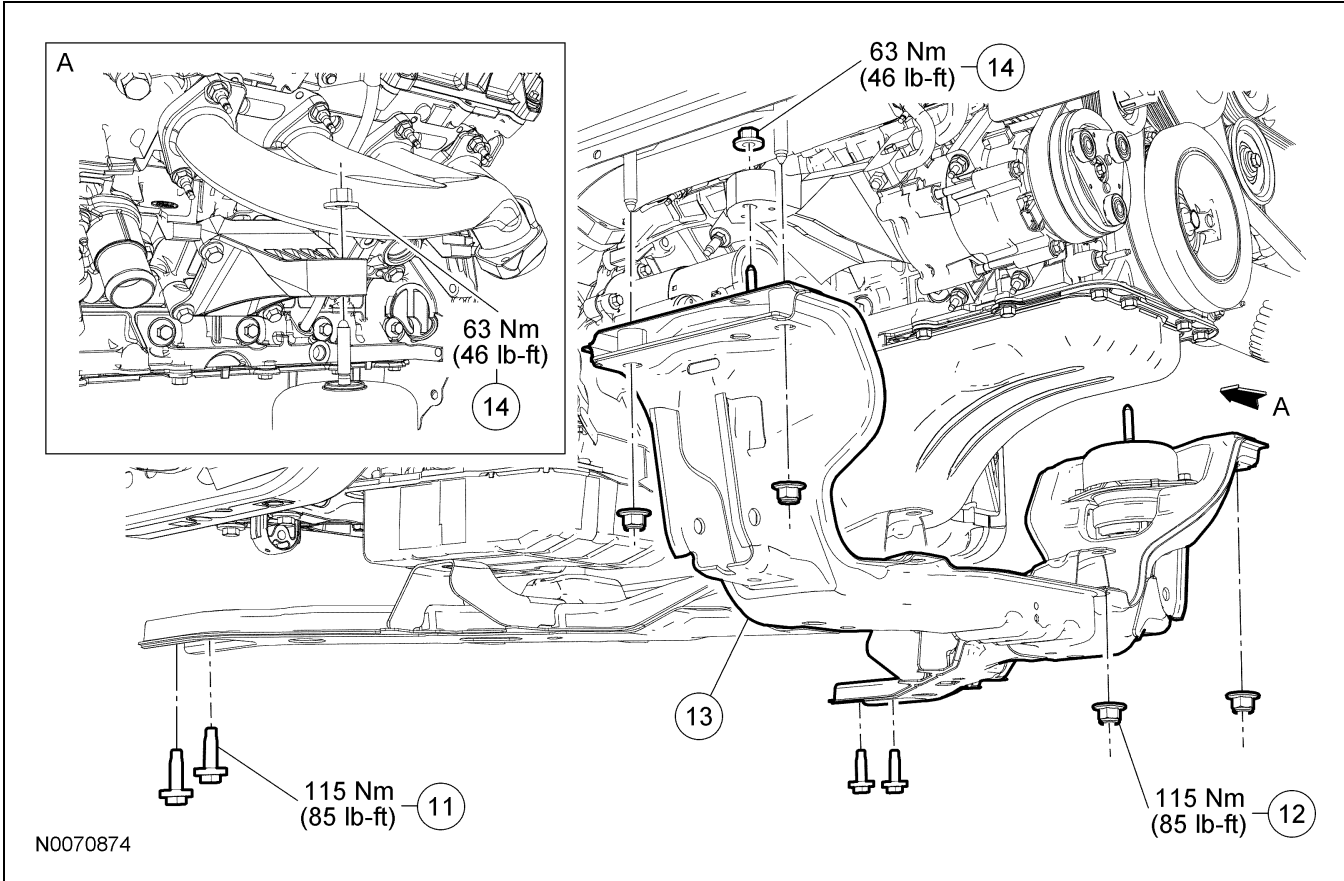

Item	Part Number	Description
11	W711075	Subframe bolt (4 required)
12	W707246	Subframe nut (4 required)
13	5025	Subframe

Item	Part Number	Description
14	N621943	Engine support insulator nut (2 required)

(Continued)

IN-VEHICLE REPAIR (Continued)

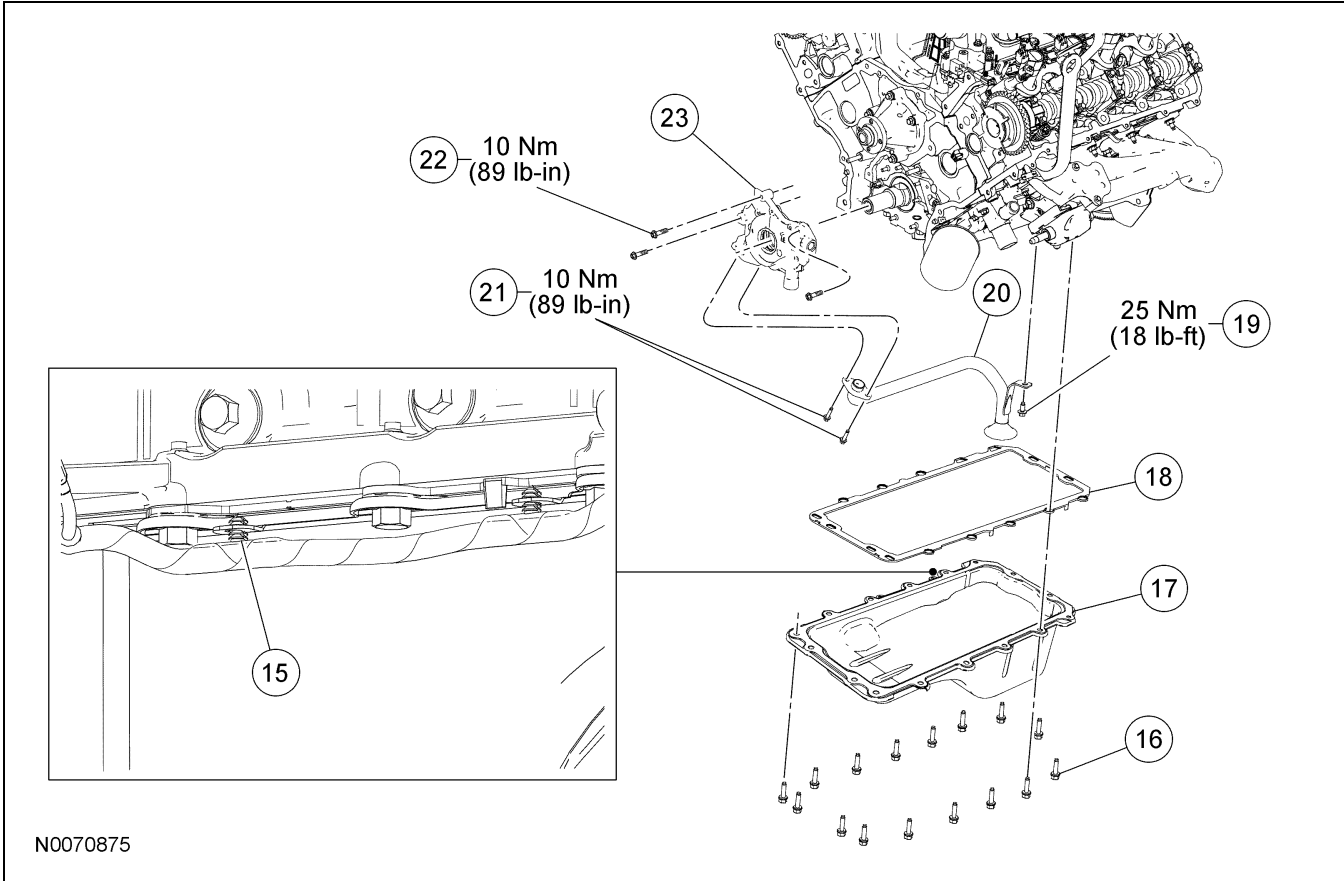

Item	Part Number	Description
15	—	Pin-type retainer (2 required) (part of 12B637)
16	W701605	Oil pan bolt (16 required)
17	6675	Oil pan
18	6710	Oil pan gasket
19	N605904	Oil pump screen and pickup tube-to-spacer bolt
20	6622	Oil pump screen and pickup tube

Item	Part Number	Description
21	N806155	Oil pump screen and pickup tube-to-oil pump bolts (2 required)
22	N806183	Oil pump bolt (3 required)
23	6621	Oil pump

1. For additional information, refer to the procedures in this section.

(Continued)