

## DESCRIPTION AND OPERATION

### Engine

**NOTE:** For information, refer to the exploded view under the Assembly procedure in this section.

The 4.6L (3V) is a V-8 engine with the following features:

- Single overhead camshafts
- Three valves per cylinder
- Sequential Multi-Port Fuel Injection (SFI)
- Aluminum cylinder heads
- Aluminum cylinder block
- Variable Camshaft Timing (VCT)
- Individually chain-driven camshafts with a hydraulic timing chain tensioner on each timing chain
- Distributorless ignition system
- Electronic returnless fuel system

### Identification

Always refer to these labels when installation of new parts is necessary or when checking engine calibrations. The engine parts often differ within a CID family. Verification of the identification codes will make sure that the correct parts are obtained. These codes contain all of the pertinent information relating to the dates, optional equipment and revisions. The Ford Master Parts Catalog contains a complete listing of the codes and their applications.

### Engine Code Information Label

The engine code information label is located on the side of the LH valve cover, it contains the following:

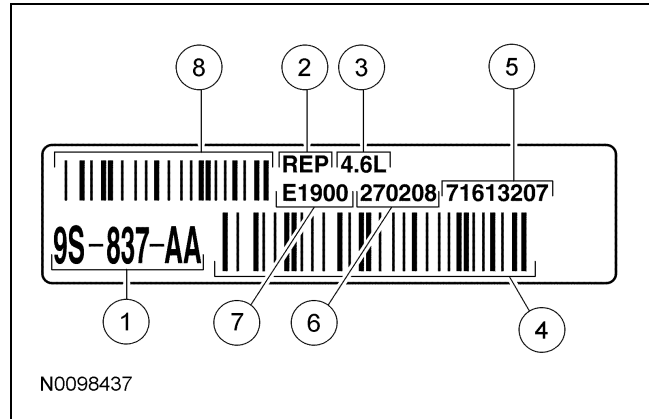

Item	Description
1	Engine part number
2	Romeo engine plant
3	Engine displacement
4	Bar code
5	Running number
6	Engine build date (DDMMYY)
7	Plant shift line
8	Bar code

## DESCRIPTION AND OPERATION (Continued)

### Engine Cylinder Identification

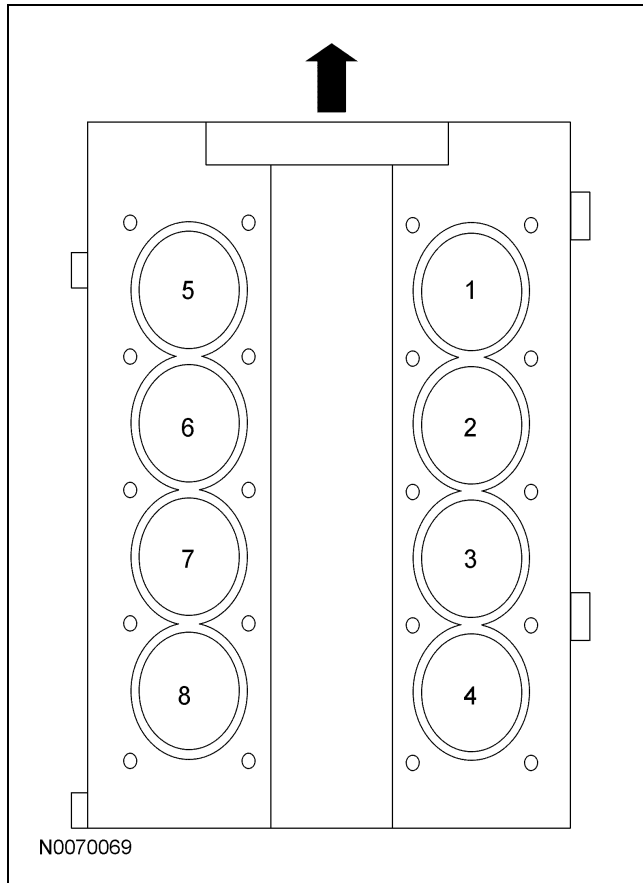

### Induction System

The SFI provides the fuel/air mixture needed for combustion in the cylinders. The 8 solenoid-operated fuel injectors:

- are mounted in the intake manifold.
- meter fuel into the air intake stream in accordance with engine demand.
- are positioned so that their tips direct fuel just ahead of the engine intake valves.
- are connected in series with the fuel rail pressure and temperature sensor.
- supply fuel from the fuel tank with a fuel pump mounted in the fuel tank.

A constant fuel pressure is maintained across the fuel injectors by the fuel rail pressure and temperature sensor. The fuel rail pressure and temperature sensor is positioned upstream from the fuel injectors on the fuel rail.

### Valve Train

The valve train operates as follows:

- Ball-tip hydraulic lash adjusters provide automatic lash adjustment.
- Roller followers ride on the camshaft lobe, transferring the up-and-down motion of the camshafts to the valves in the cylinder heads.

### Positive Crankcase Ventilation System

All engines are equipped with a closed-type positive crankcase ventilation system recycling the crankcase vapors to the upper intake manifold.

### Lubrication System

The engine lubrication system operates as follows:

- Oil is drawn into the oil pump through the oil pump screen cover and tube in the sump of the oil pan.
- Oil is pumped through the oil filter on the left front side of the cylinder block.
- Oil enters the main gallery where it is distributed to the crankshaft main journals and to both cylinder heads.
- From the main journals, the oil is routed through cross-drilled passages in the crankshaft to lubricate the connecting rod bearings. Controlled leakage through the crankshaft main bearings and connecting rod bearings is slung radially outward to cool and lubricate the cylinder walls as well as the entire connecting rod, piston and piston ring assembly.
- The left cylinder head is fed from a drilling into the supply passage feeding the main gallery at the front of the cylinder block. The right cylinder head is fed from a drilling into the rear of the main gallery. Main gallery pressure is reduced as it enters the cylinder head galleries through fixed serviceable orifices, located at the upper part of the feed passages. It is this reduced pressure in the cylinder head galleries which feeds the camshaft journals, the hydraulic lash adjusters and the primary and secondary timing chain tensioners.
- The oil pressure feed for the Variable Camshaft Timing (VCT) solenoids, VCT housings and camshaft phaser and sprockets is not reduced.
- The camshaft lobe and roller followers are lubricated by splash created through valve train operation.

DESCRIPTION AND OPERATION (Continued)

Engine Oil Flow Illustrations

Engine Assembly

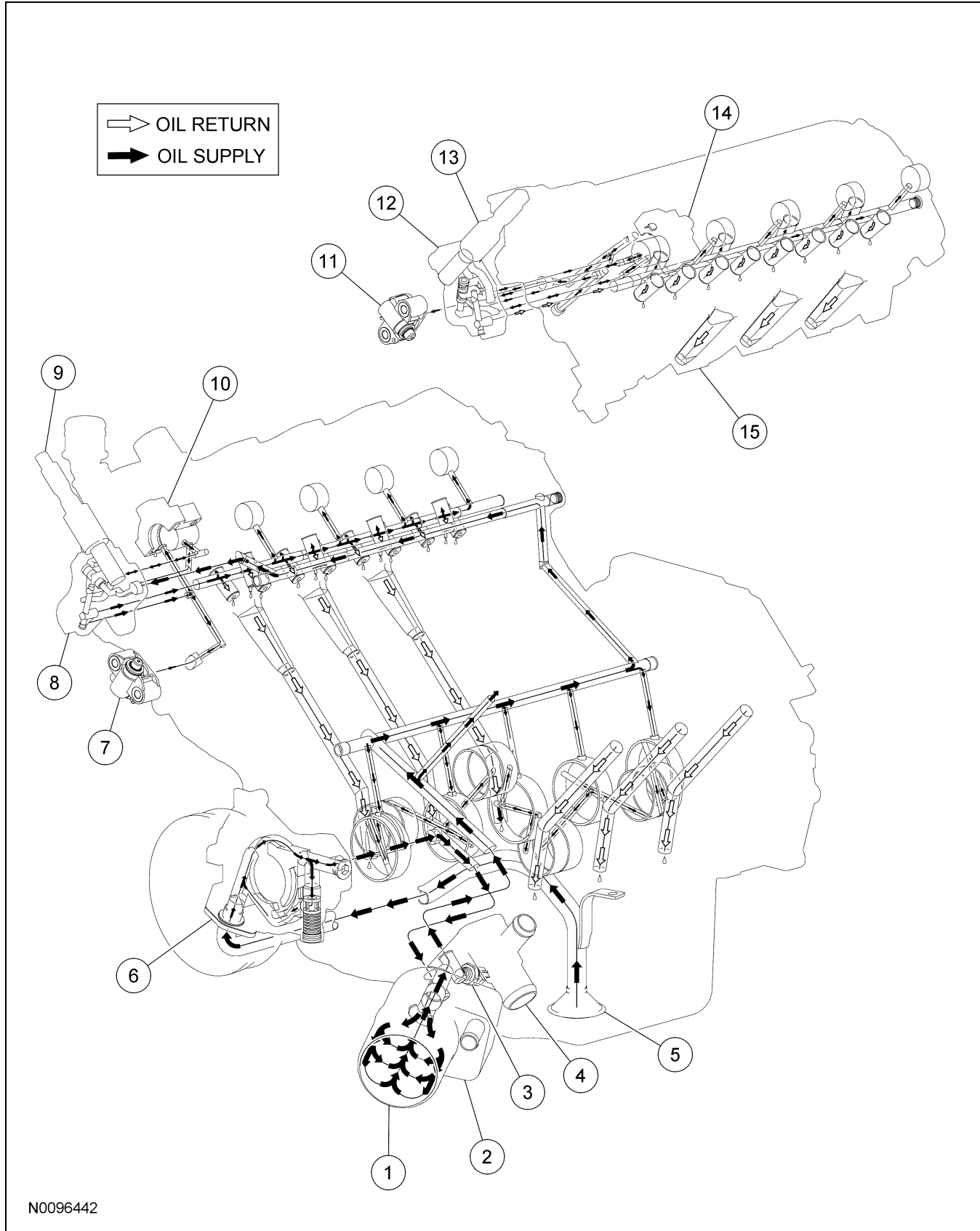

N0096442

**DESCRIPTION AND OPERATION (Continued)**

Item	Part Number	Description
1	6714	Oil filter
2	6A642	Oil cooler (if equipped)
3	9278	Engine Oil Pressure (EOP) switch
4	6884	Oil filter adapter
5	6622	Oil pump screen and pickup tube
6	6621	Oil pump
7	6L266A	Timing chain tensioner — RH
8	6C260	Variable Camshaft Timing (VCT) housing — RH

Item	Part Number	Description
9	6M280	VCT oil control solenoid assembly — RH
10	6B284	Front camshaft bearing cap — RH
11	6L266B	Timing chain tensioner — LH
12	6C261	VCT housing — LH
13	6M280	VCT oil control solenoid assembly — LH
14	6B284	Front camshaft bearing cap — LH
15	6050	Cylinder head — LH

(Continued)

**Camshaft Phaser and Sprocket, Camshaft Phaser and Sprocket Bolt and Camshaft**

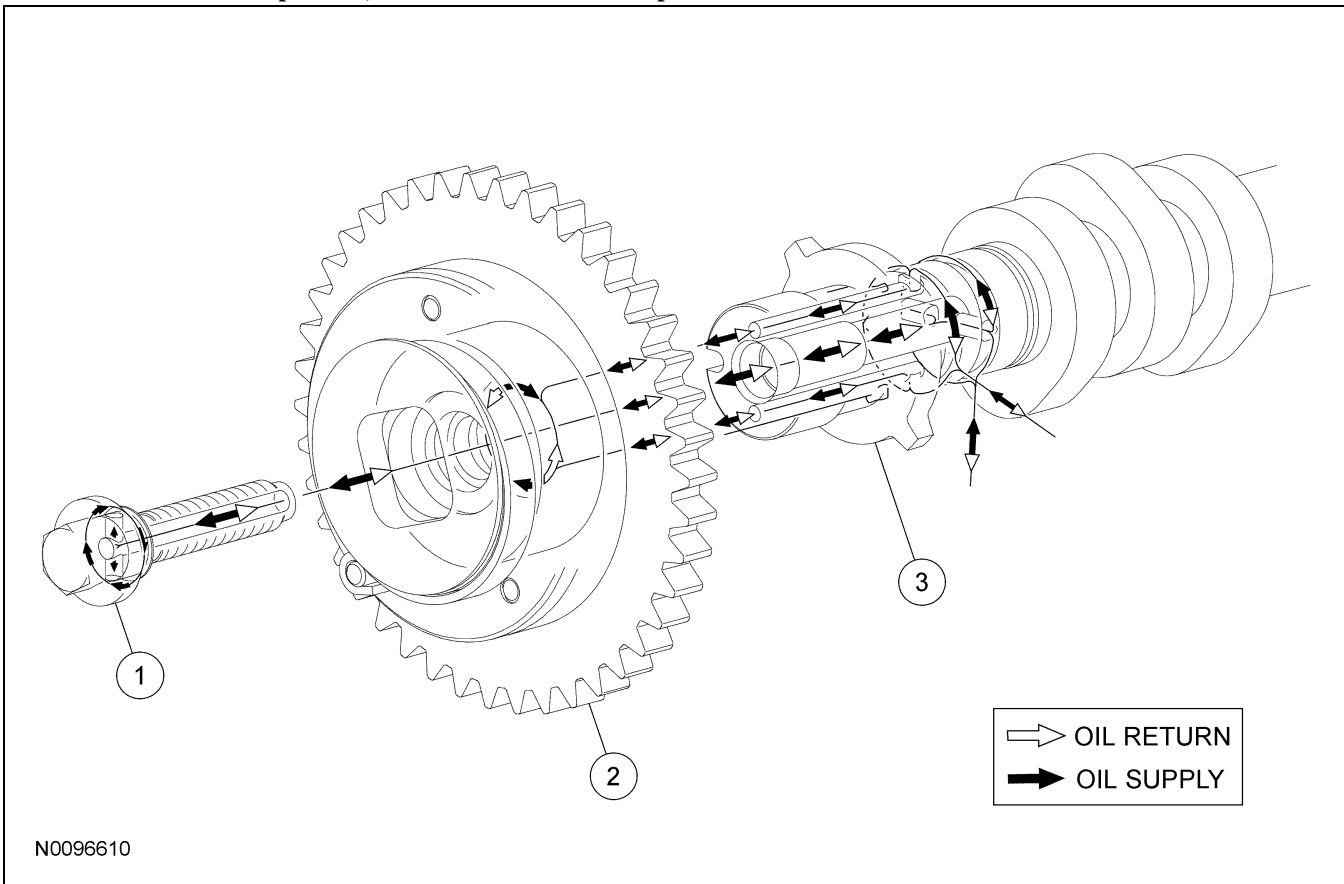

Item	Part Number	Description
1	6279	Camshaft phaser and sprocket bolt
2	6256	Camshaft phaser and sprocket
3	—	Camshaft

**DESCRIPTION AND OPERATION (Continued)**

**LH Variable Camshaft Timing (VCT) Housing, VCT Solenoid and Timing Chain Tensioner**

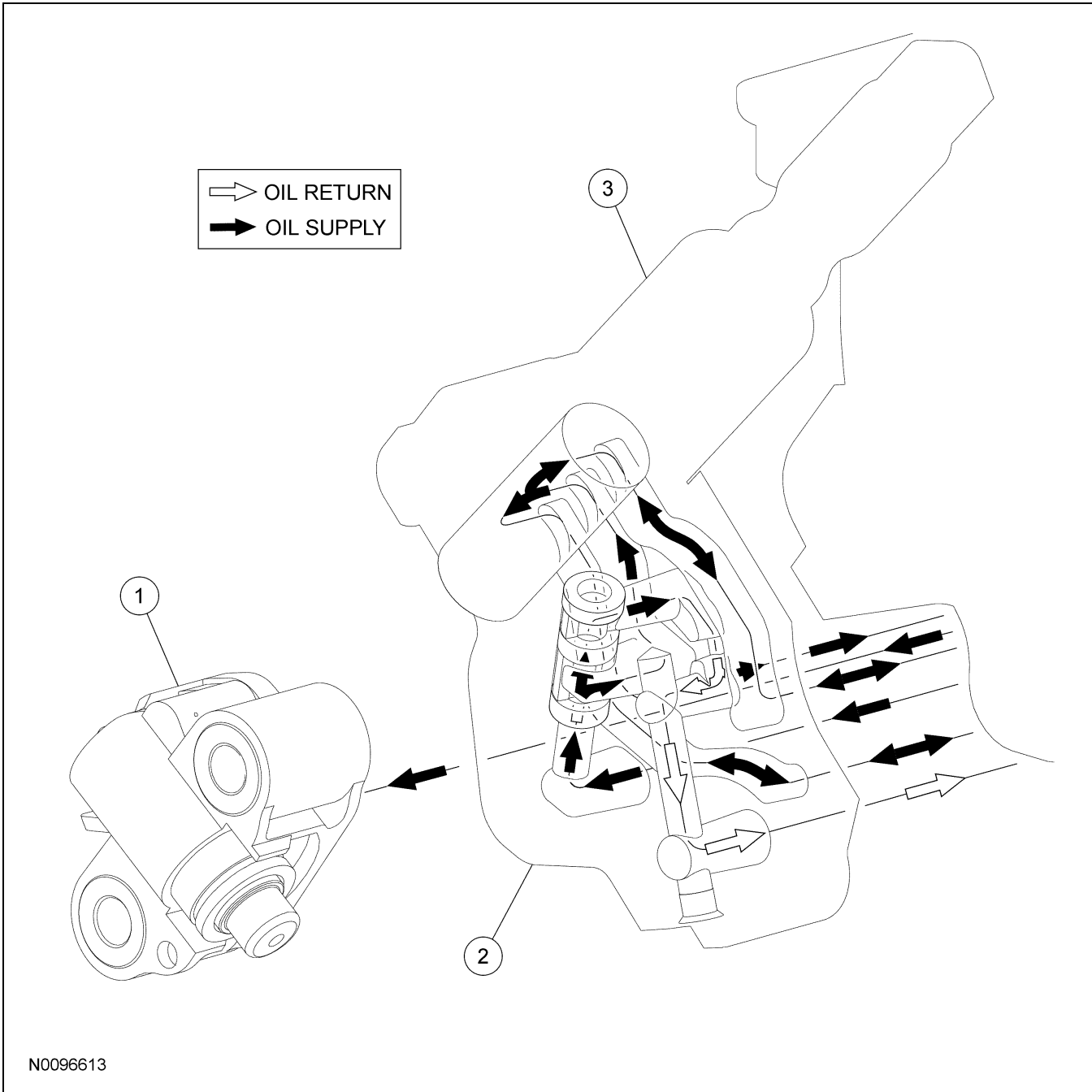

N0096613

Item	Part Number	Description
1	6L266B	Timing chain tensioner — LH
2	6C261	Variable Camshaft Timing (VCT) housing — LH

Item	Part Number	Description
3	6M280	VCT oil control solenoid assembly — LH

(Continued)

**DESCRIPTION AND OPERATION (Continued)**

**RH Variable Camshaft Timing (VCT) Housing and VCT Solenoid**

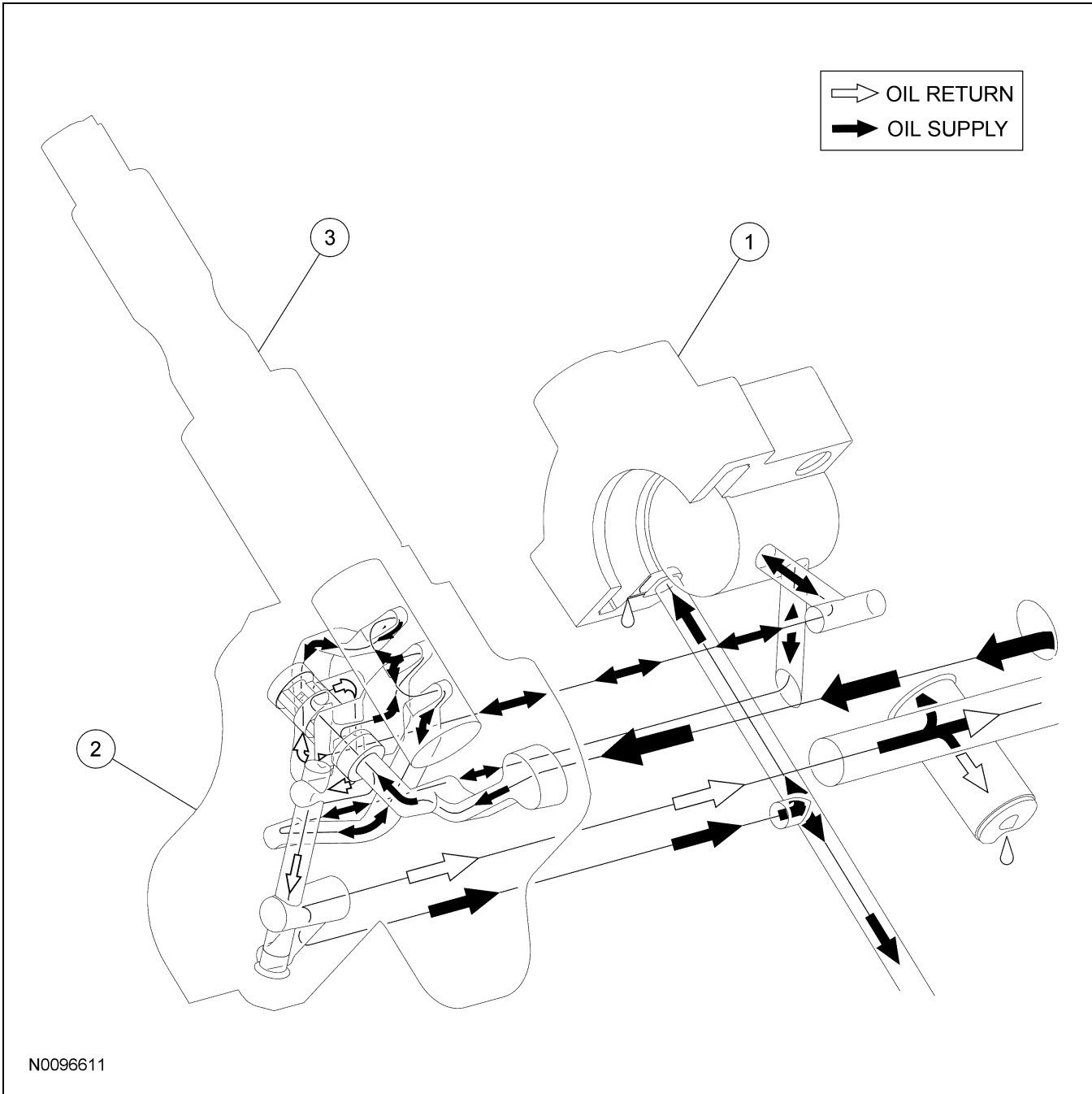

N0096611

Item	Part Number	Description
1	6M280	Front camshaft bearing cap — RH
2	6C261	Variable Camshaft Timing (VCT) housing — RH

Item	Part Number	Description
3	6C260	VCT oil control solenoid assembly — RH

(Continued)

**DESCRIPTION AND OPERATION (Continued)**

**Variable Camshaft Timing (VCT) Housing**

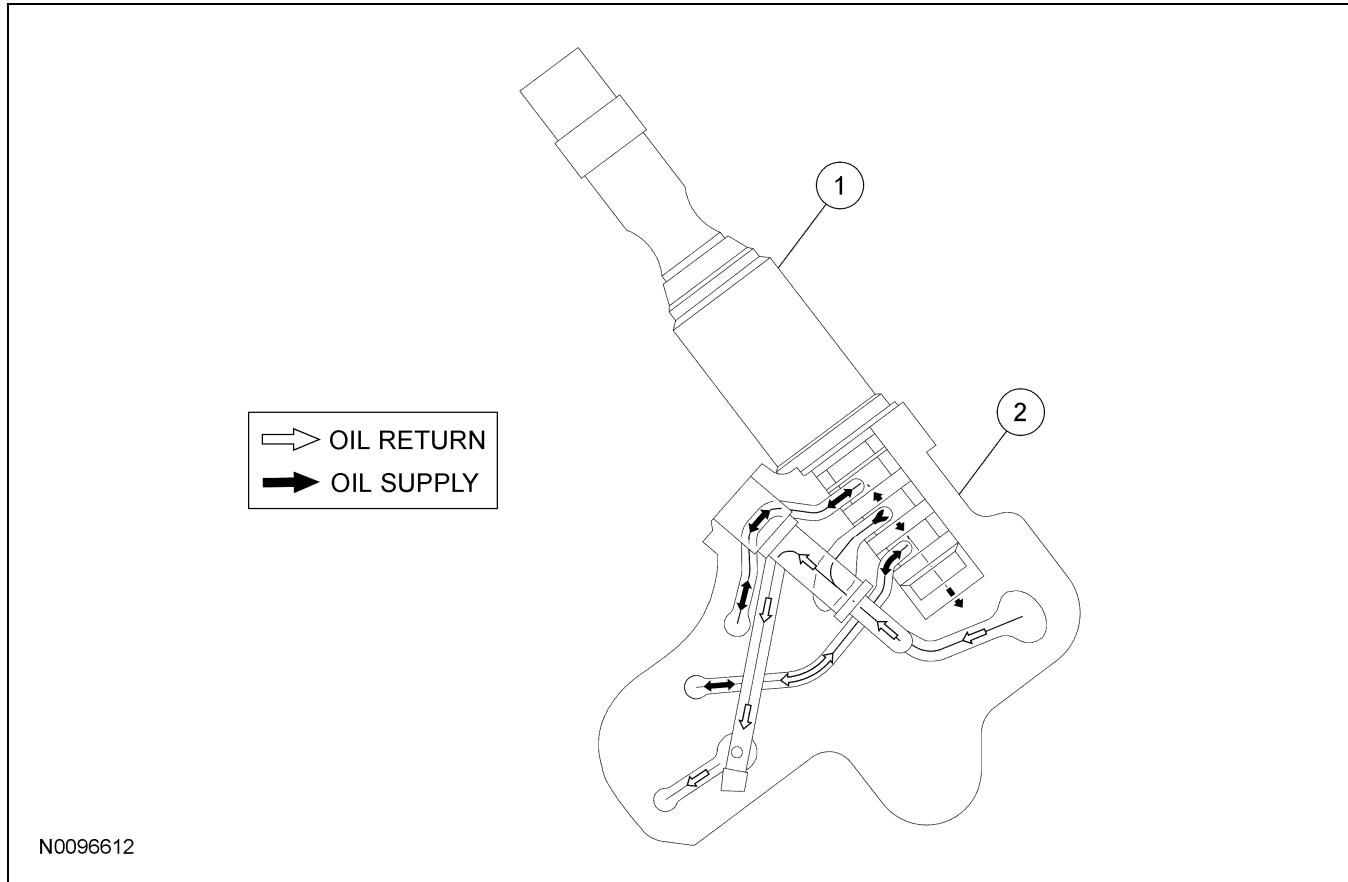

N0096612

Item	Part Number	Description
1	—	Variable Camshaft Timing (VCT) oil control solenoid assembly
2	—	VCT housing

**Oil Pump**

The lubrication system is designed to provide optimum oil flow to critical components of the engine through its entire operating range. The heart of the system is a positive displacement internal gear oil pump using top seal rotors. Generically this design is known as a gerotor pump, which operates as follows:

- The oil pump is mounted on the front face of the cylinder block.

- The inner rotor is piloted on the crankshaft post and is driven through flats on the crankshaft.
- System pressure is limited by an integral, internally-vented relief valve which directs the bypassed oil back to the inlet side of the oil pump.
- Oil pump displacement has been selected to provide adequate volume to make sure of correct oil pressure, both at hot idle and maximum speed.
- The relief valve calibration protects the system from excessive pressure during high-viscosity conditions.
- The relief valve is designed to provide adequate connecting rod bearing lubrication under high-temperature and high-speed conditions.