

Upper Intake Manifold

Upper Intake Manifold (View 1 of 2)

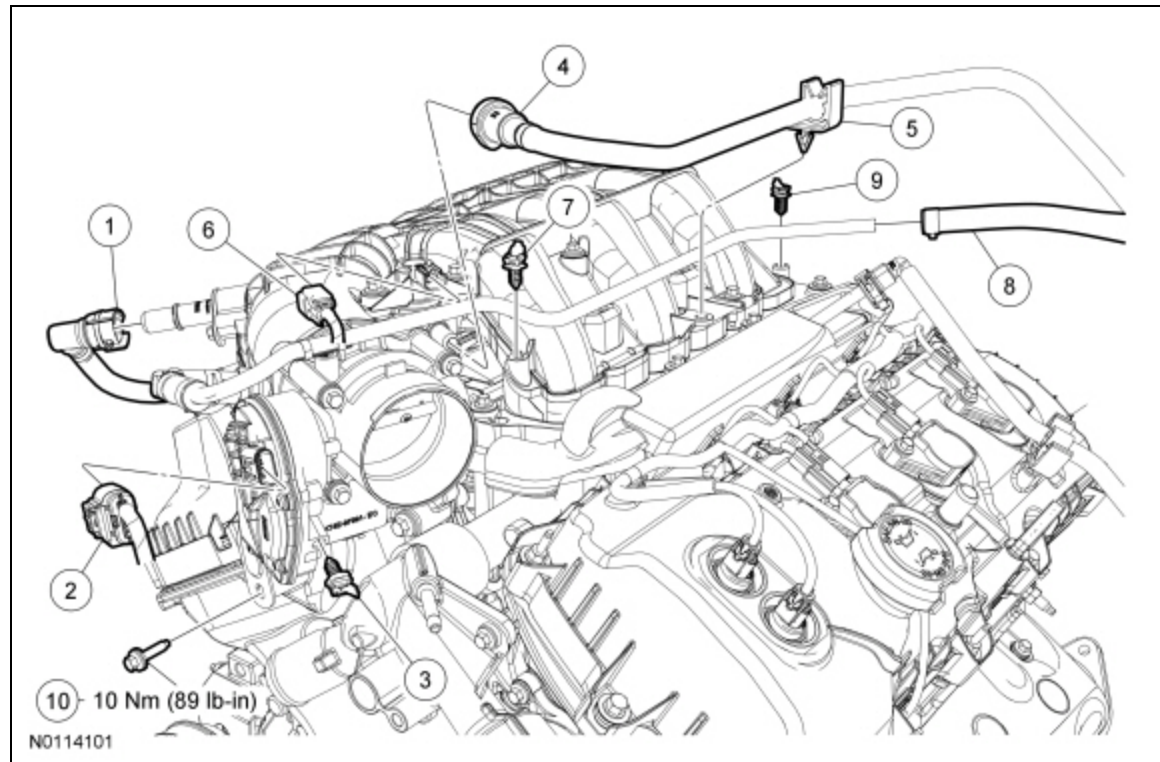

Item	Part Number	Description
1	6A664	PCV tube quick connect coupling
2	—	Throttle Body (TB) electrical connector (part of 12C508)
3	—	<u>TB</u> electrical connector wiring harness pin-type retainer (part of 12C508)
4	9J280	Evaporative Emission (EVAP) tube
5	—	<u>EVAP</u> hose retainer (part of 9J280)
6	—	<u>EVAP</u> canister purge valve electrical connector (part of 12C508)
7	—	<u>EVAP</u> canister purge valve electrical connector wiring harness pin-type retainer (part of 12C508)
8	—	Brake booster vacuum hose (part of 9C482)
9	—	Wiring harness pin-type retainer (part of 12C508)
10	W503275	Upper intake manifold support bracket bolt

Upper Intake Manifold (View 2 of 2)

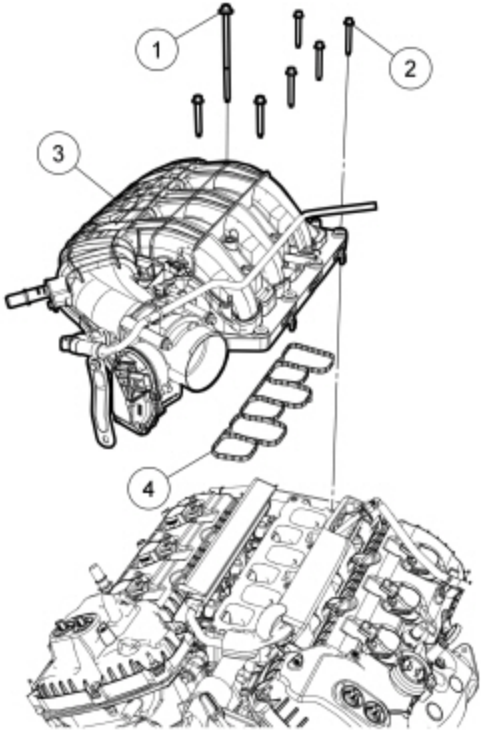

N0114102

Item	Part Number	Description
1	W715096	Upper intake manifold bolt
2	9Y450	Upper intake manifold bolt (6 required)
3	9424	Upper intake manifold
4	9H486	Upper intake manifold gasket

Removal

1. **NOTE:** LH shown, RH similar.

If equipped, remove the 4 nuts (2 shown) and the strut tower cross brace.

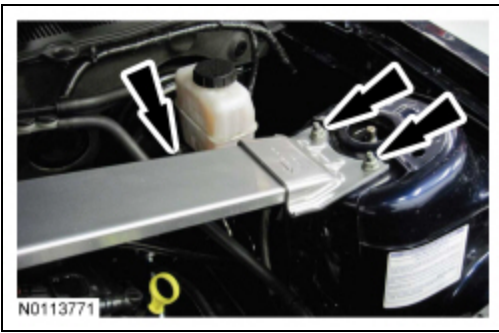

2. If equipped, detach the 2 retainers and remove the engine appearance cover.



3. Remove the Air Cleaner (ACL) outlet tube. For additional information, refer to Intake Air System Components — Exploded View, 3.7L in [Section 303-12](#).

4. Disconnect the PCV tube quick connect coupling from the intake manifold. For additional information, refer to [Section 310-00](#).

5. Disconnect the Throttle Body (TB) electrical connector.

- Detach the TB electrical connector wiring harness pin-type retainer from the TB .

6. Disconnect Evaporative Emission (EVAP) tube from the EVAP canister purge valve. For additional information, refer to [Section 310-00](#).

- Detach the EVAP hose retainer from the intake manifold.

7. Disconnect the EVAP canister purge valve electrical connector.

- Detach the EVAP canister purge valve electrical connector wiring harness pin-type retainer.

8. Disconnect the brake booster vacuum hose from the upper intake manifold vacuum tube.

9. Detach the wiring harness pin-type retainer from the rear of the upper intake manifold.

10. Remove the upper intake manifold support bracket bolt from the front of the RH cylinder head.

11. Loosen the 7 bolts and remove the upper intake manifold.

- Remove and discard the gaskets.
- Clean and inspect all of the sealing surfaces of the upper and lower intake manifold.

Installation

1. **NOTICE:** If the engine is repaired or replaced because of upper engine failure, typically including valve or piston damage, check the intake manifold for metal debris. If metal debris is found, install a new intake manifold. Failure to follow these instructions can result in engine damage.

Using new gaskets, install the upper intake manifold and tighten the 7 bolts in the sequence shown in 2 stages.

- Stage 1: Tighten to 10 Nm (89 lb-in).
- Stage 2: Tighten an additional 45 degrees.

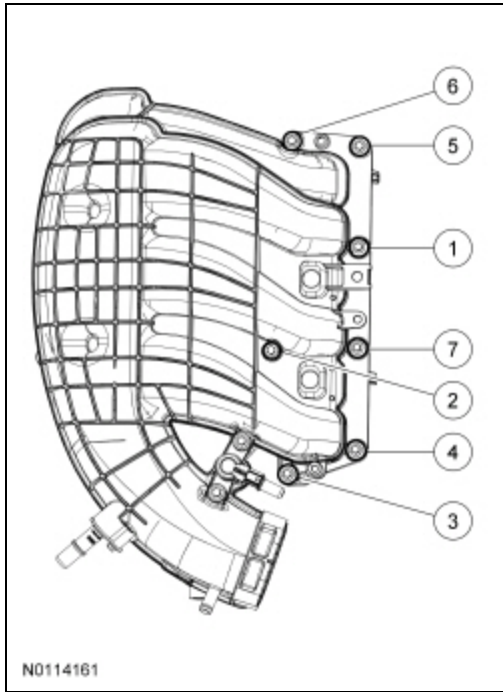

2. Install the upper intake manifold support bracket bolt to the RH cylinder head.
 - Tighten to 10 Nm (89 lb-in).
3. Attach the wiring harness pin-type retainer to the rear of the upper intake manifold.
4. Connect the brake booster vacuum hose to the upper intake manifold vacuum tube.
5. Connect the EVAP canister purge valve electrical connector.
 - Attach the EVAP canister purge valve electrical connector wiring harness pin-type retainer.
6. Connect EVAP tube to the EVAP canister purge valve. For additional information, refer to [Section 310-00](#).
 - Attach the EVAP hose retainer to the intake manifold.
7. Connect the TB electrical connector.
 - Attach the TB electrical connector wiring harness pin-type retainer to the TB .
8. Connect the PCV tube quick connect coupling to the intake manifold. For additional information, refer to [Section 310-00](#).
9. Install the ACL outlet tube. For additional information, refer to Intake Air System Components — Exploded View, 3.7L in [Section 303-12](#).
10. If equipped, install the engine appearance cover.



11. **NOTE:** *LH shown, RH similar.*

If equipped, install the strut tower cross brace and the 4 nuts (2 shown).

- Tighten to 35 Nm (26 lb-ft).

