

US INSTALLATION INSTRUCTION - HOOD SCOOP KIT

E INSTRUCCIONES DE INSTALACION - KIT DE ENTRADA DE AIRE DEL COFRE

F INSTRUCTIONS D'INSTALLATION - KIT POUR PRISE D'AIR DU CAPOT



ACCESSORIZE YOUR VEHICLE AT: FORDACCESSORIES.COM
BUSQUE ACCESORIOS PARA SU VEHICULO EN: FORDACCESSORIES.COM
PERSONNALISEZ VOTRE VEHICULE D'ACCESSOIRES A: FORDACCESSORIES.COM

Subject to alteration without notice
Reservadas modificaciones tecnicas
Sous r serve de modifications techniques

MUSTANG 2010

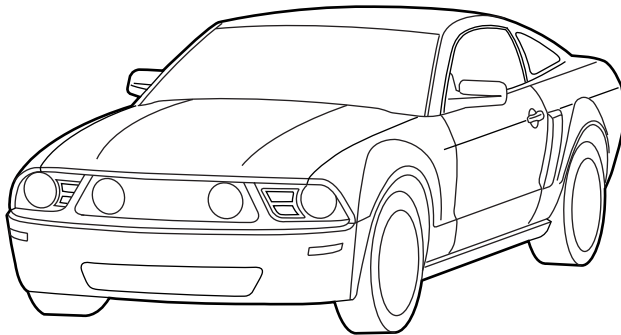

PERSONAL INJURY
LESIONES PERSONALES
RISQUE DE BLESSURE



VEHICLE DAMAGE
DANO DE VEHICULO
DOMMAGE AU VEHICULE



INCORRECT
INCORRECTO
INCORRECT



CORRECT
CORRECTO
CORRECT



SEE MANUAL
VER MANUAL
VOIR LE MANUEL

A 	D BLACK NEGRO NOIR 1x	G 592 mm
B 	E WHITE BLANCO BLANC 3x	H 704 mm 2x
C 	F 2x	L 740 mm
	I 	K ALCOHOL PAD 2x
	J 	M 5x



TOOLS REQUIRED
HERRAMIENTAS NECESARIAS
OUTILS NÉCESSAIRES

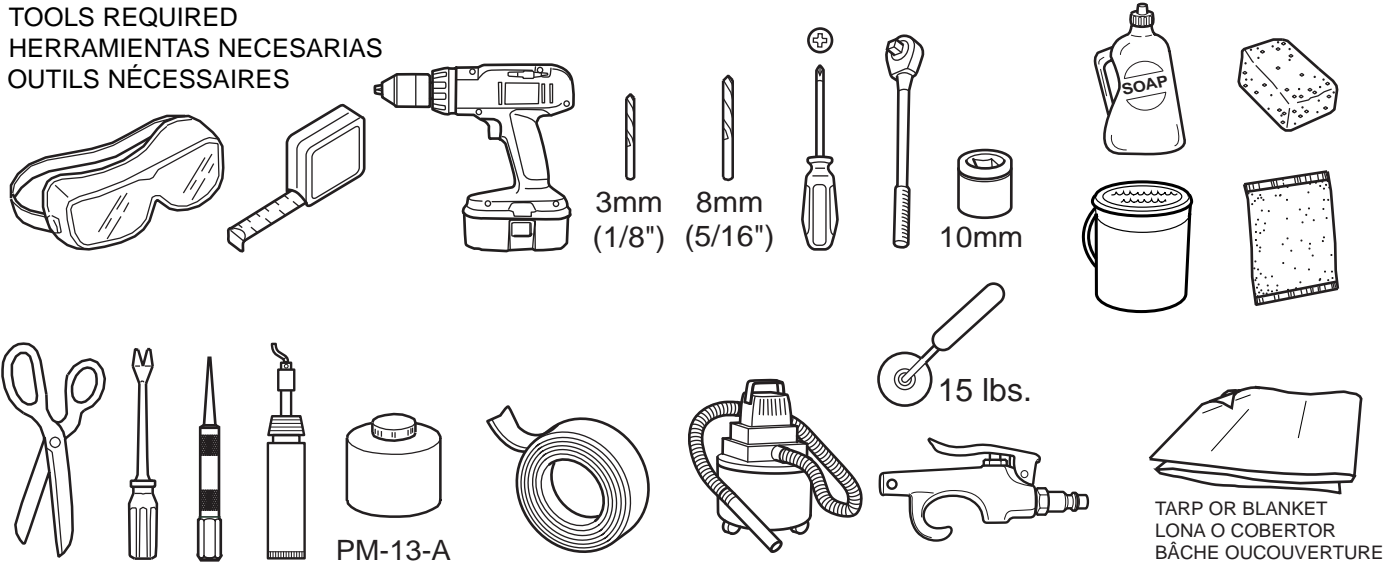

1

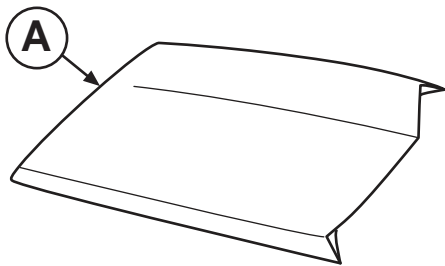
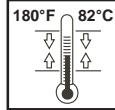

NOTE: PAINT TO MATCH, MASK ACCORDINGLY
NOTA: PINTURA A EMPAREJAR, ENMASCARAR POR
CONSIGUIENTE
REMARQUE: PEINTURE À ASSORTIR, MASQUER EN
CONSEQUENCE

2

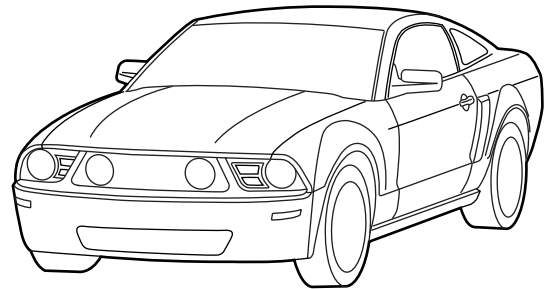
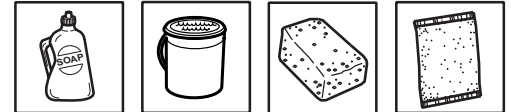

3

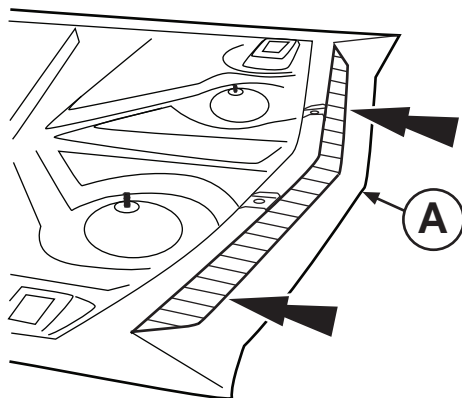

4

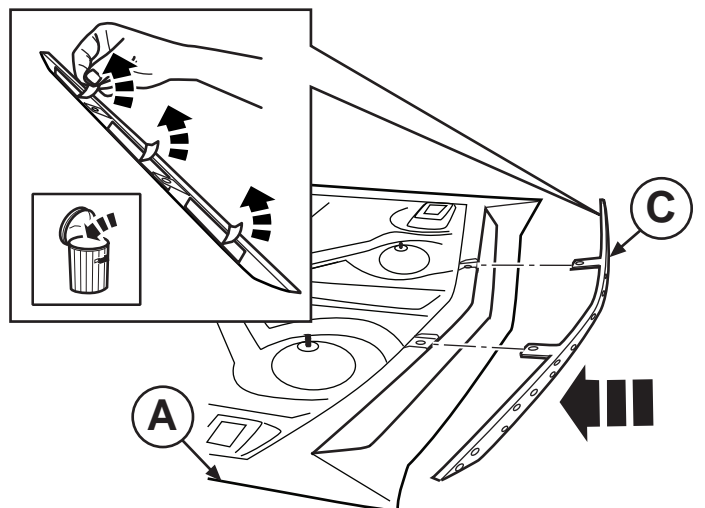

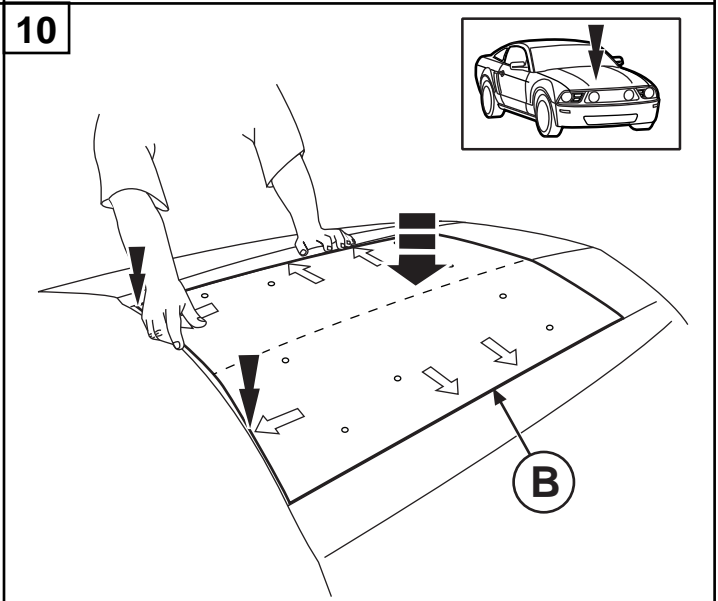
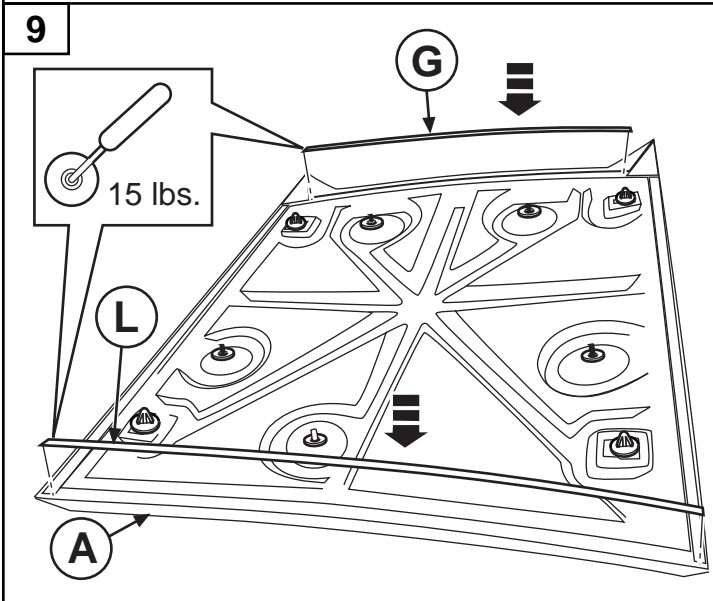
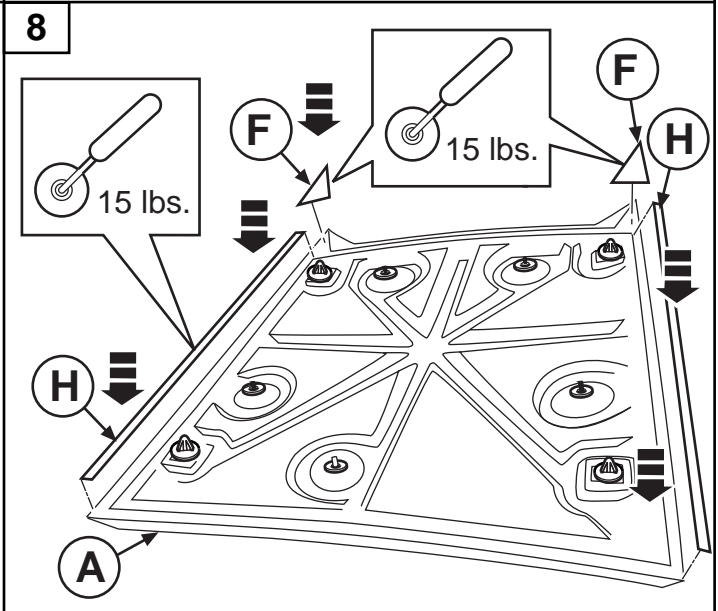
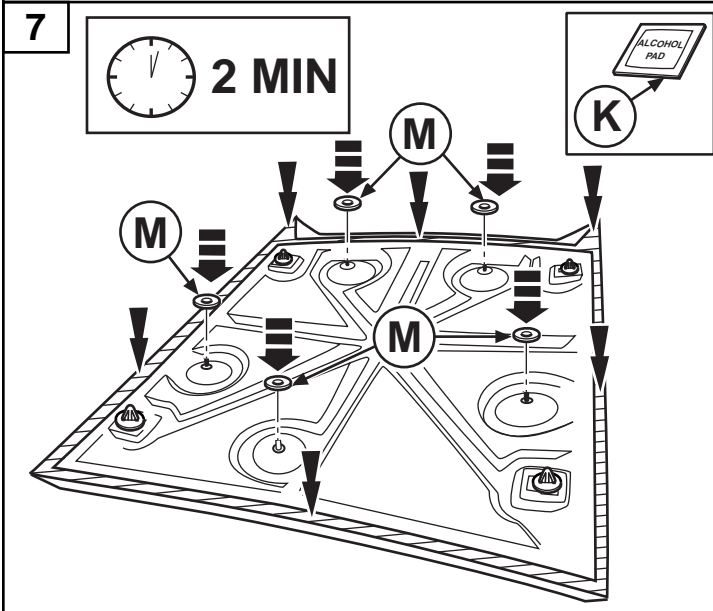
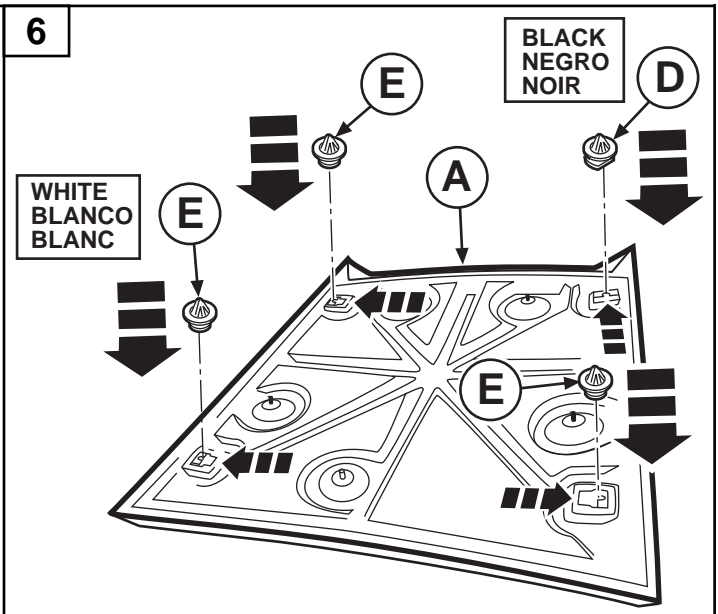
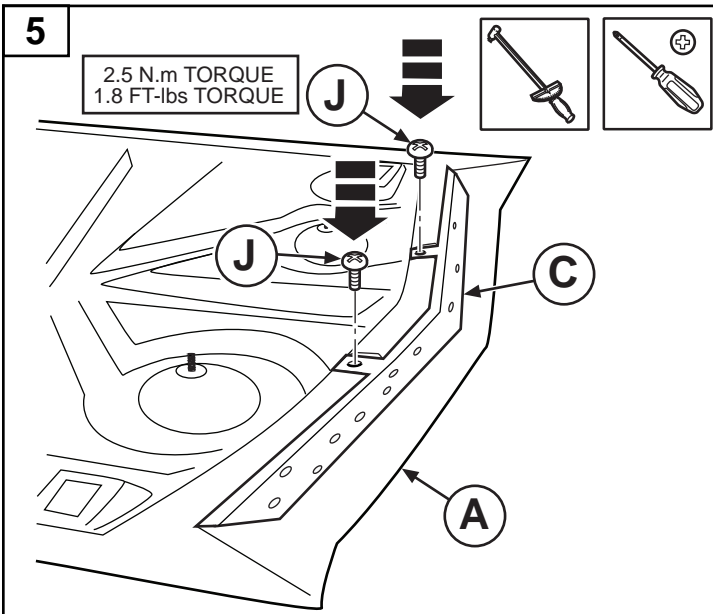

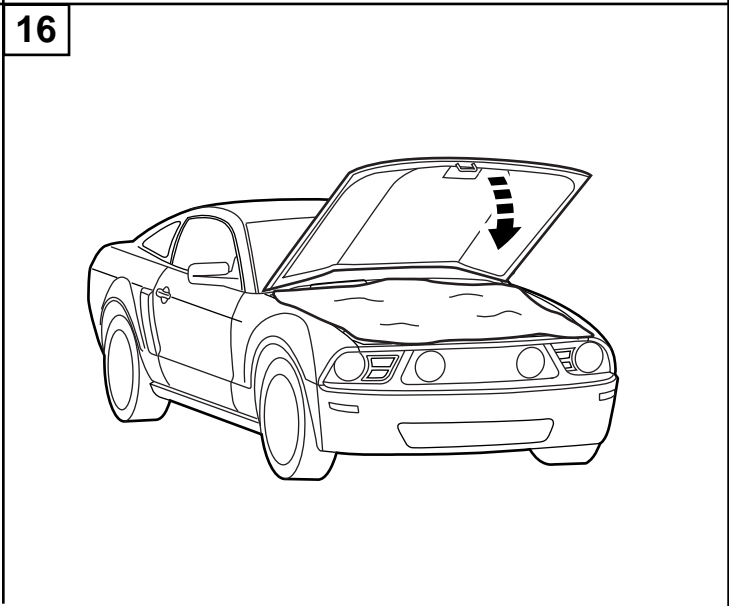
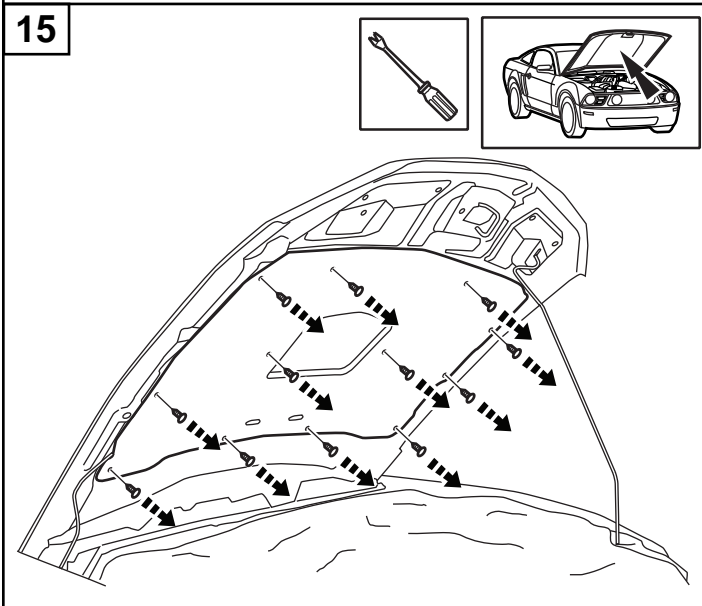
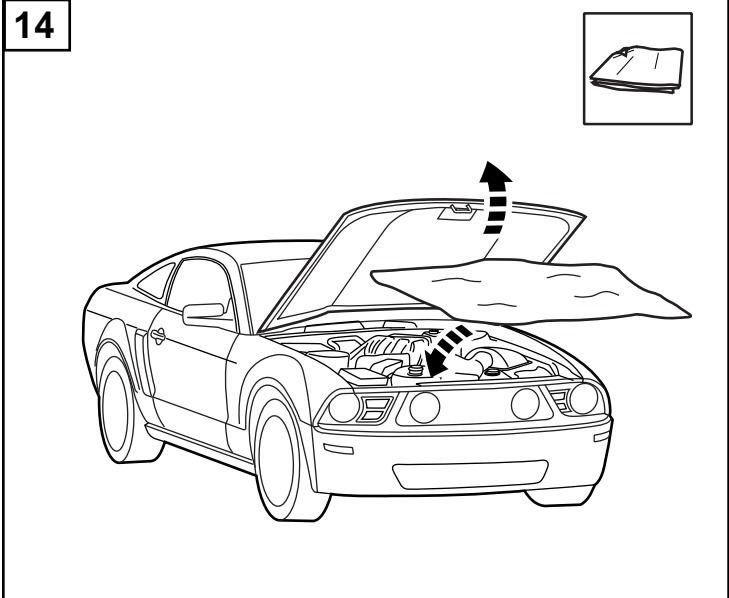
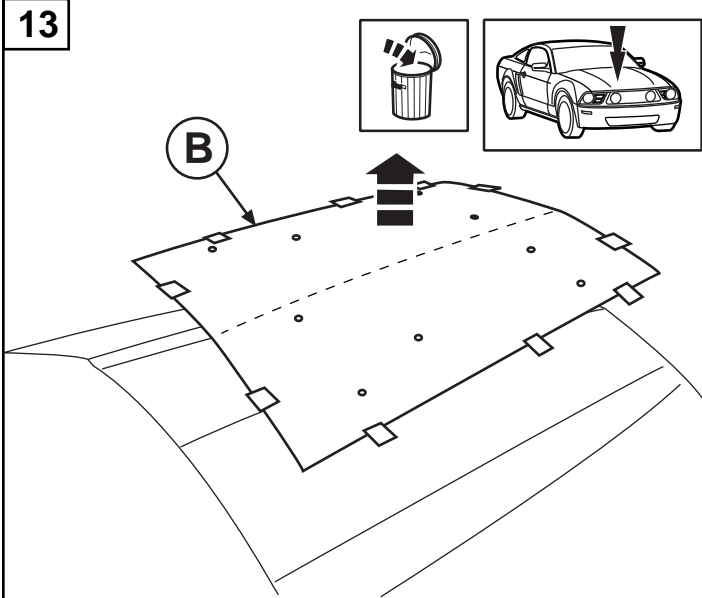
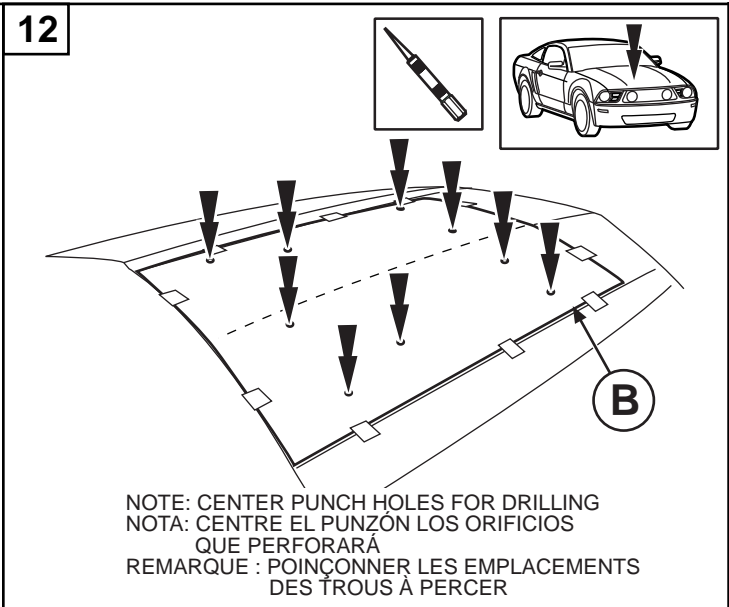
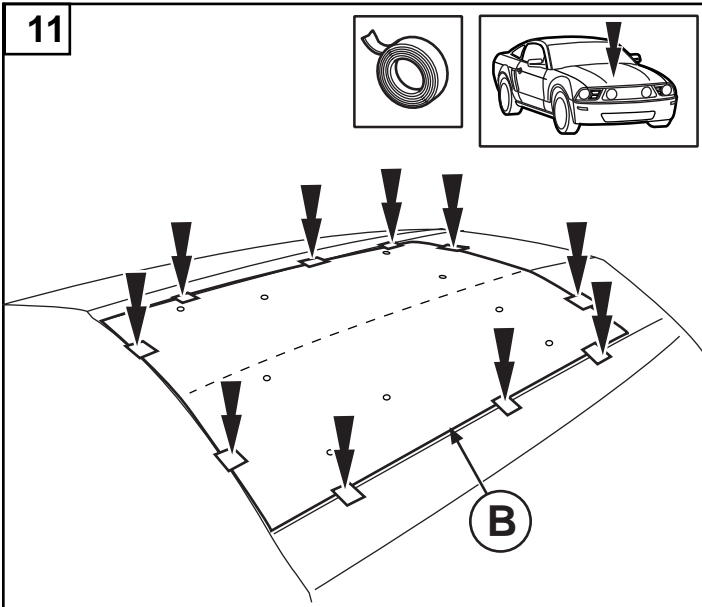

17

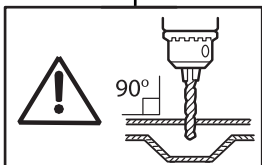
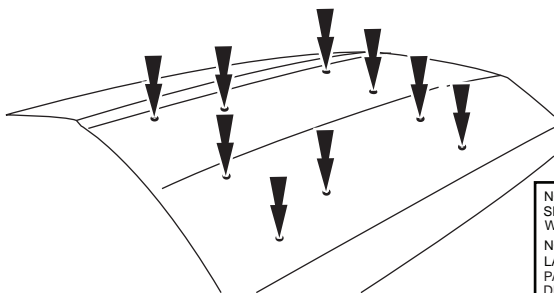
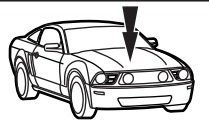
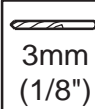

NOTE: DRILL ONLY THROUGH OUTER SHEET METAL TO AVOID DAMAGE TO WIPER HOSE UNDER PANEL.
 NOTA: PERFORE SÓLO A TRAVÉS DE LA LÁMINA METÁLICA EXTERIOR. PARA EVITAR DAÑOS A WIPER MANGUERA DEBAJO DEL PANEL.
 REMARQUE : NE PERCER QUE DANS LA TÔLE EXTÉRIEURE, POUR ÉVITER D'ENDOMMAGER LE TUYAU D'ESSUIE-GLACE SOUS LE PANNEAU.

NOTE: USE MINIMAL PRESSURE WHEN DRILLING TO AVOID DENTING OF HOOD
 NOTA: CUANDO PERFORE, UTILICE UNA PRESIÓN MÍNIMA PARA EVITAR QUE EL COFRE SE DAÑE
 REMARQUE : PERCER LES TROUS AVEC UNE PRESSION MINIMALE POUR ÉVITER DE BOSSELER LE CAPOT

18

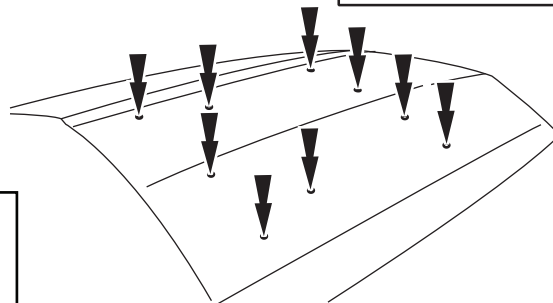
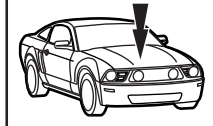
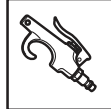
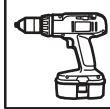
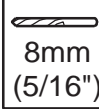

NOTE: USE MINIMAL PRESSURE WHEN DRILLING TO AVOID DENTING OF HOOD
 NOTA: CUANDO PERFORE, UTILICE UNA PRESIÓN MÍNIMA PARA EVITAR QUE EL COFRE SE DAÑE
 REMARQUE : PERCER LES TROUS AVEC UNE PRESSION MINIMALE POUR ÉVITER DE BOSSELER LE CAPOT

19

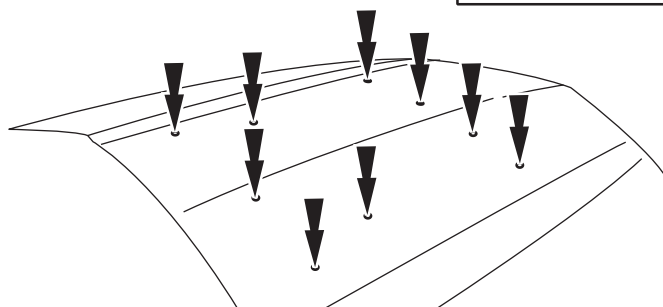
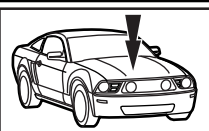

NOTE: VACUUM & WIPE SURFACE WITH 50/50 ALCOHOL WIPE
 NOTA: ASPIRE Y FROTE LA SUPERFICIE CON UNPAÑO HUMEDECIDO EN ALCOHOL AL 50/50.
 REMARQUE: RETIREZ LES COPEAUX À L'AIDE D'UN ASPIRATEUR ET ESSUYEZ LA SURFACE AVEC UNE SERVIETTE À 50/50 D'ALCOOL/EAU.

20

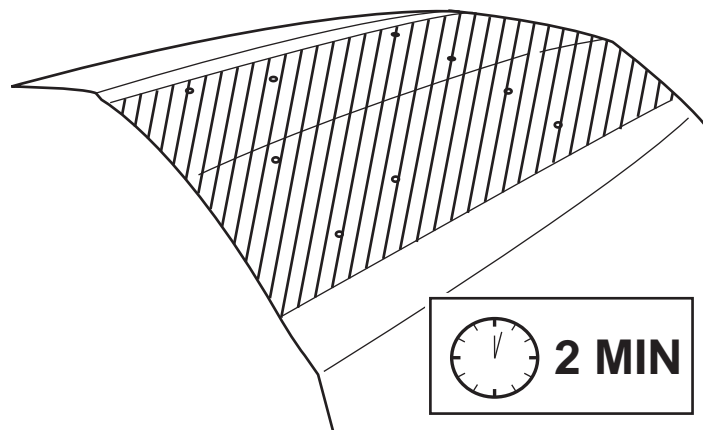
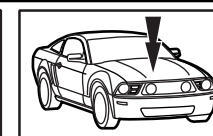

21

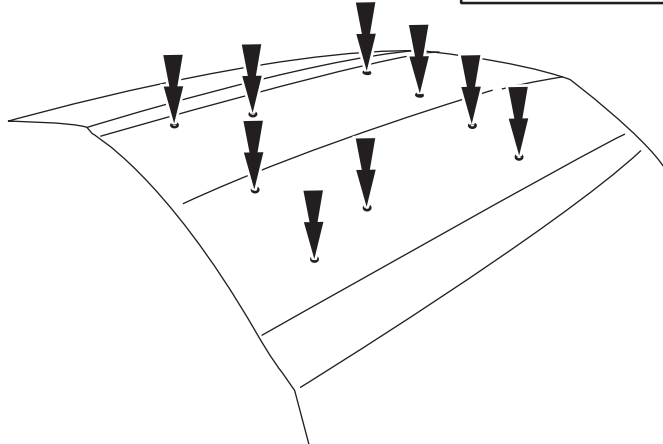
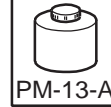

22

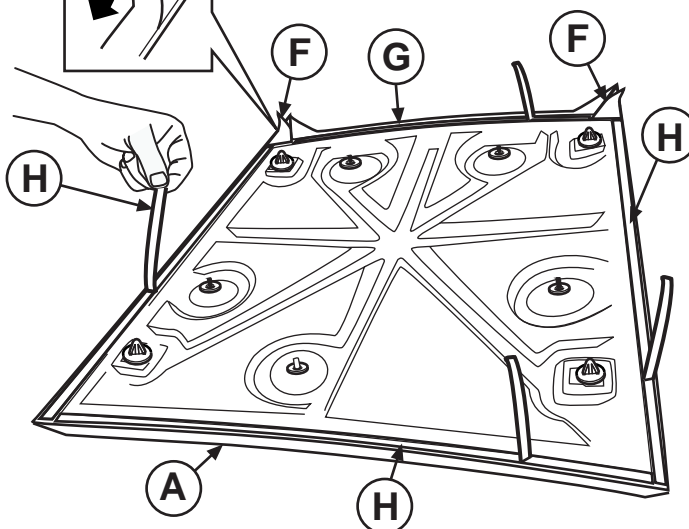

23

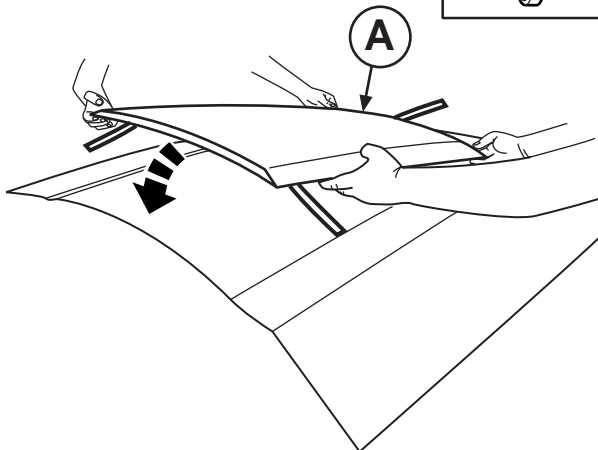
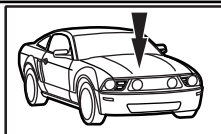

24

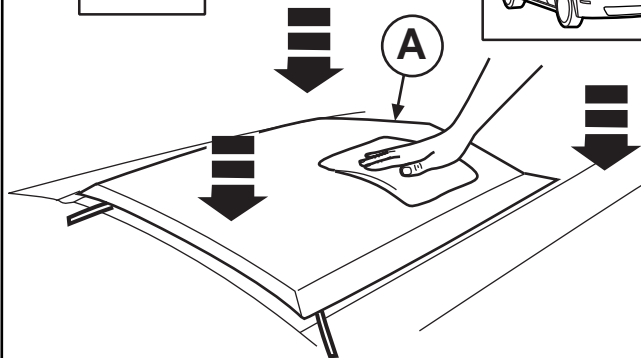
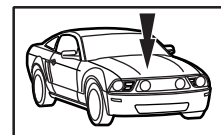

NOTE: APPLY HAND PRESSURE TO MAKE SURE CLIPS ARE FULLY SEATED.
NOTA: APLIQUE PRESIÓN MANUAL PARA ASEGURARSE DE QUE LOS SUJETADORES ESTÉN BIEN ASENTADOS.
REMARQUE : FAIRE PRESSION AVEC LA MAIN POUR S'ASSURER QUE LES CLIPS SONT BIEN LOGÉS EN PLACE.

25

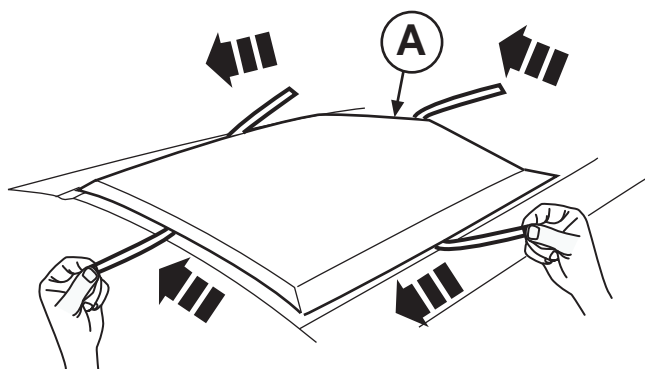
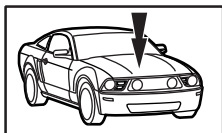

26

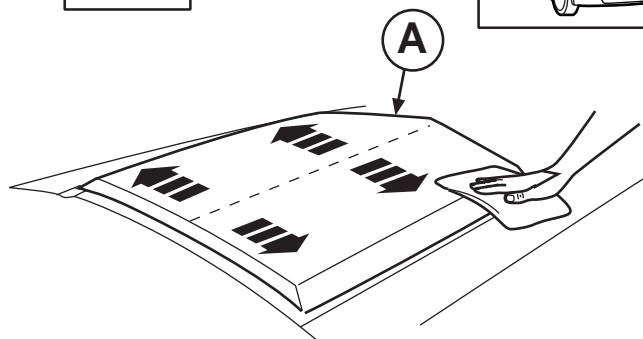
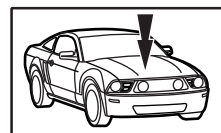

NOTE: APPLY HAND PRESSURE
NOTA: APLIQUE PRESIÓN MANUAL PARA ASEGURARSE
REMARQUE : FAIRE PRESSION AVEC LA MAIN POUR S'ASSURER

27

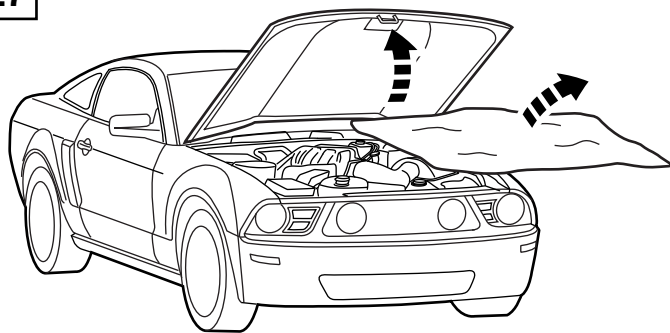

REMOVE WITH CAUTION.
TENGA CUIDADO AL QUITAR.
RETIRER AVEC PRÉCAUTION.

NOTE: VACUUM & CLEAN SURFACE.
NOTA: ASPIRE Y FROTE LA SUPERFICIE CON UNPAÑO.
REMARQUE: RETIREZ LES COPEAUX À L'AIDE D'UN ASPIRATEUR

28

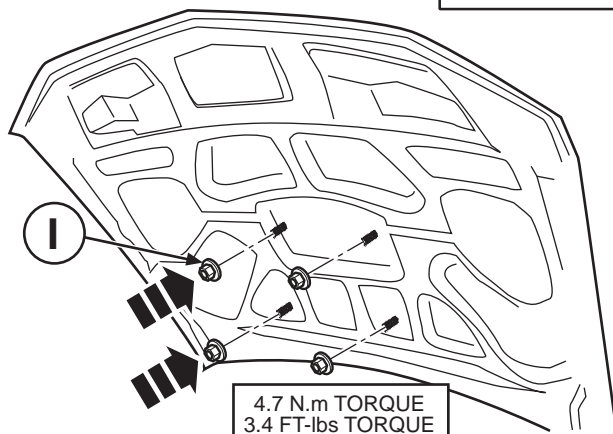
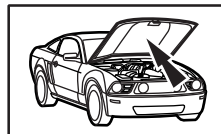
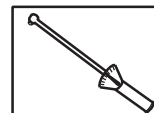

4.7 N.m TORQUE
3.4 FT-lbs TORQUE

29

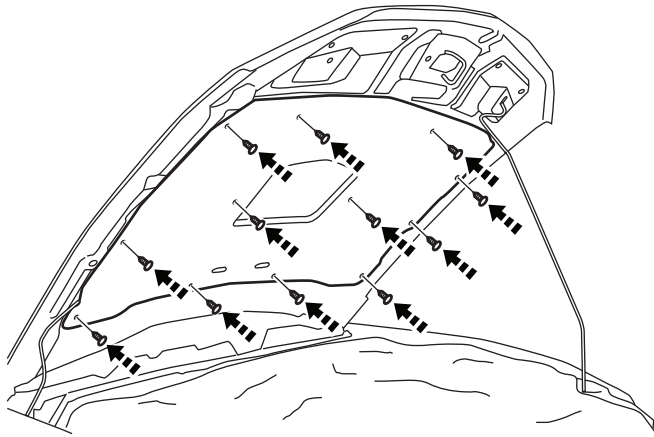
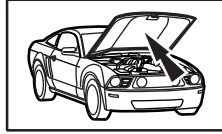

30

5 Hrs.



24 Hrs.



Congratulations!

You've purchased a Genuine Ford Brand Accessory designed, engineered, and built specifically for your Ford vehicle. We have made every effort to ensure that the Hood Scoop Kit is top quality in terms of fit, finish, and ease of installation.

At Ford Customer Service Division,
customer satisfaction is our number one priority!

¡Felicidades!

Acaba de comprar un Accesorio marca Ford Genuino, diseñado y construido específicamente para su vehículo Ford. Hemos realizado todos los esfuerzos necesarios para que de Entrada de Aire Del Cofre sea de la mejor calidad en cuanto a ajuste, durabilidad acabado y zfacilidad de instalacionz

Para la División de Atención al Cliente de Ford,
la satisfacción del cliente es nuestra principal prioridad.

Félicitations !

Vous avez acheté un accessoire Ford d'origine conçu, étudié et fabriqué spécialement pour votre véhicule Ford. Nous avons pris toutes les mesures nécessaires pour assurer que ce Kit Pour Prise D' Air Du Capot est d'une qualité supérieure en ce qui concerne l'ajustement, la zdurabilité, la finition et la facilité d'installation.

Pour la division du service après-vente Ford, la satisfaction du client a priorité absolue !



Ford Customer Service Divison



RACING
PERFORMANCE PARTS

ACCESSORIZE YOUR VEHICLE AT: FORDACCESSORIES.COM
BUSQUE ACCESORIOS PARA SU VEHICULO EN: FORDACCESSORIES.COM
PERSONNALISEZ VOTRE VEHICULE D'ACCESSOIRES À: FORDACCESSORIES.COM



www.fordracingparts.com

PG 717

SKAR3J-16C630-AB

© Copyright Ford 2009

