

Valve Cover — LH

Material

Item	Specification
Motorcraft® Metal Surface Prep ZC-31-A	—
Motorcraft® Silicone Gasket and Sealant TA-30	WSE-M4G323-A4
Motorcraft® Silicone Gasket Remover ZC-30	—

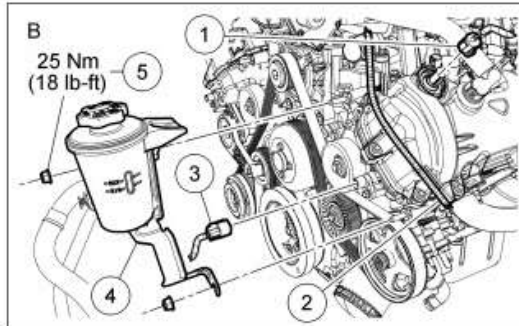
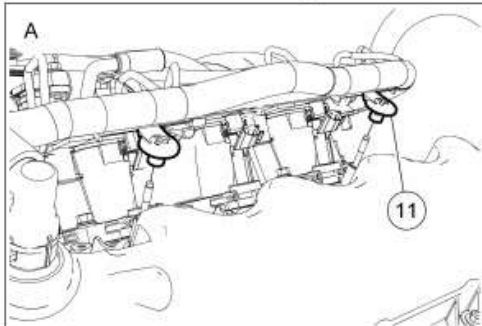
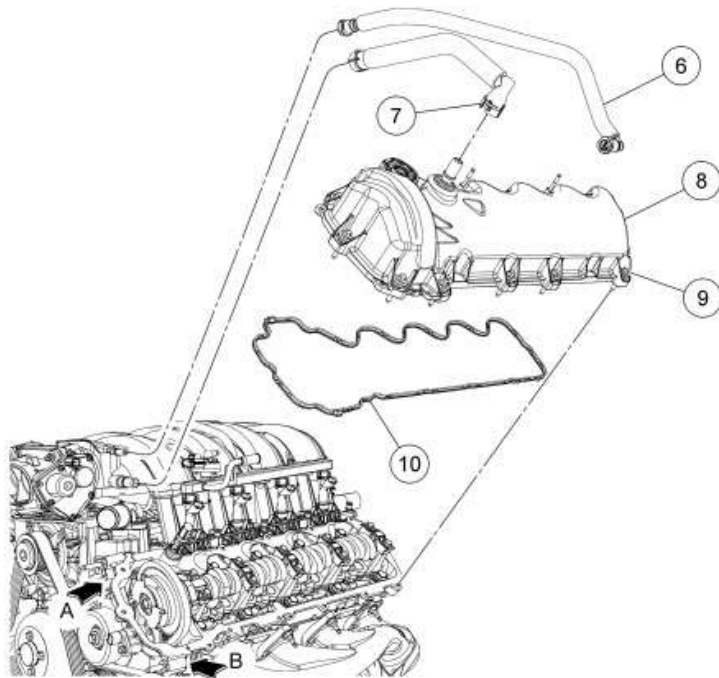

Item	Part Number	Description
1	14A464	LH Variable Camshaft Timing (VCT) solenoid electrical connector (part of 12B637)
2	—	Engine wiring harness retainer (part of 12B637) (2 required)
3	14A464	Camshaft Position (CMP) sensor electrical connector (part of 12B637)
4	3489	Power steering reservoir and bracket
5	W520112	Power steering reservoir and bracket nut (2 required)
6	9J274	Evaporative Emission (EVAP) tube
7	6K817	PCV tube
8	6A505	LH valve cover
9	6C519	LH valve cover bolt (part of 6A505) (10 required)
10	6584	LH valve cover gasket
11	—	Engine wiring harness retainer (part of 12B637) (2 required)

Removal

1. Remove the Air Cleaner (ACL) assembly and outlet pipe. For additional information, refer to [Section 303-12](#).
2. Remove the LH ignition coils. For additional information, refer to [Section 303-07B](#).
3. Remove the oil level indicator and tube. For additional information, refer to [Oil Level Indicator and Tube](#) in this section.
4. Disconnect the Evaporative Emission (EVAP) tube from the intake manifold.
5. Remove the PCV tube.
6. Disconnect the LH Variable Camshaft Timing (VCT) solenoid electrical connector and detach the 2 wiring harness pin-type retainers.
7. Detach the 2 wiring harness retainers from the valve cover stud bolts.
8. Disconnect the LH Camshaft Position (CMP) sensor electrical connector.
9. Remove the 2 nuts and position the power steering reservoir and bracket aside.
10. **NOTICE: Do not use metal scrapers, wire brushes, power abrasive discs or other abrasive means to clean the sealing surfaces. These tools cause scratches and gouges which make leak paths. Use a plastic scraping tool to remove all traces of old sealant.**

Loosen the 10 fasteners and remove the LH valve cover and gasket.

- Clean the valve cover mating surface of the cylinder head with silicone gasket remover and metal surface prep. Follow the directions on the packaging.
- Discard the valve cover gasket. Clean the valve cover gasket groove with soap and water or a suitable solvent.

Installation

1. **NOTE:** *If the valve cover is not secured within 4 minutes, the sealant must be removed and the sealing area cleaned with metal surface prep. Failure to follow this procedure can cause future oil leakage.*

Apply a bead of silicone gasket and sealant in 2 places where the engine front cover meets the cylinder head.

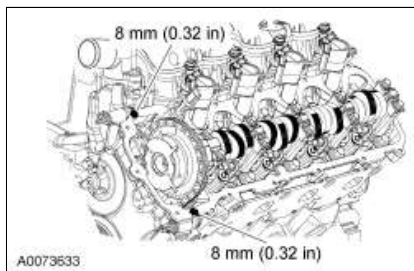

2. Position the LH valve cover and new gasket on the cylinder head and tighten the bolts in the sequence shown.
 - Tighten to 10 Nm (89 lb-in).

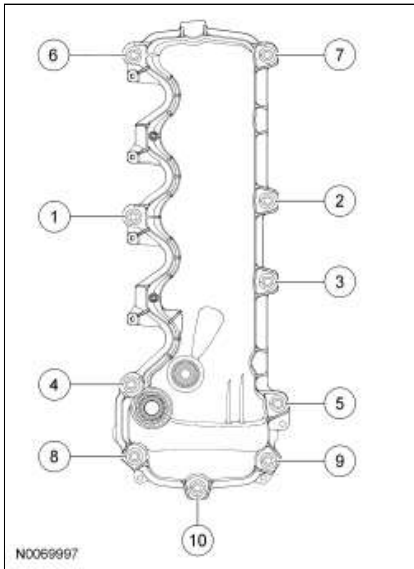

3. Install the power steering reservoir and bracket and the 2 nuts.
 - Tighten to 25 Nm (18 lb-ft).
4. Connect the LH CMP electrical connector.
5. Attach the 2 wiring harness retainers to the valve cover stud bolts.
6. Connect the LH VCT solenoid electrical connector and attach the 2 wiring harness pin-type retainers.
7. Install the PCV tube.
8. Connect the EVAP tube to the intake manifold.
9. Install the oil level indicator and tube. For additional information, refer to [Oil Level Indicator and Tube](#) in this section.
10. Install the LH ignition coils. For additional information, refer to [Section 303-07B](#).
11. Install the ACL assembly and output pipe. For additional information, refer to [Section 303-12](#).

