

## DIAGNOSIS AND TESTING

### Manual Transmission and Clutch

#### Principles of Operation

The clutch master cylinder transmits fluid pressure to the clutch slave cylinder, which in turn moves the clutch release bearing. The clutch hydraulic system uses brake fluid and shares a reservoir with the brake system. The clutch disc has frictional material where it contacts the flywheel and the clutch pressure plate. The clutch pressure plate applies pressure to the clutch disc, holding it tightly against the surface of the flywheel.

In the engaged position, the clutch pressure plate diaphragm spring holds the clutch pressure plate against the clutch disc, so that the engine torque is transmitted to the input shaft. When the clutch is depressed, movement is transmitted through the clutch hydraulic system, which actuates the clutch release bearing. The clutch release bearing pushes on the spring center toward the flywheel. The diaphragm spring pivots at the fulcrum, relieving the load on the clutch pressure plate. Steel spring straps riveted in the clutch pressure plate cover pull the clutch pressure plate from the clutch disc, disengaging the engine torque from the transmission.

#### Inspection and Verification

 **CAUTION:** If transmission noise is reported, first check the fluid level. The vehicle should not be driven if the fluid level is low. A low fluid level will damage the transmission.

**NOTE:** Before attempting to rectify any concerns, road test the vehicle to ascertain in which system the concern falls.

**NOTE:** If an obvious cause for an observed or reported concern is found, correct the cause (if possible) before proceeding.

A gear driven unit will produce a certain amount of noise. Some noise is acceptable and audible at certain speeds or under various driving conditions. Certain conditions, such as road and weather, will amplify normal vehicle noise.

The following overview is a guide to diagnose a transmission/clutch concern:

- Verify and document the customer concern.
  - During the customer interview, if a leak was noticed or if a leak is the concern, check the transmission fluid. The vehicle should not be driven if the fluid level is low.
- Check fluid level and condition.
- Evaluation of the clutch hydraulic system.
- Evaluation of the clutch.
- Inspect gearshift mechanism.
- Evaluation of the transmission.
- Find the cause of the problem and correct it.

#### Verify Customer Concern

1. Verify and document the customer concern.
  - 1 When was it first noticed?
  - 2 Did it appear suddenly or gradually?
  - 3 Did anything unusual occur that would coincide with it or precede it?
  - 4 Identify when the condition occurs:
    - Hot or cold vehicle operating conditions.
    - Type of terrain.
    - City/highway driving.
    - Driving at a particular speed.
      - coasting.
      - hard acceleration.
    - Shifting.
      - upshifts.
      - downshifts.
      - in a particular gear.
      - in all gears.
    - Hot or cold ambient temperatures.
  - 5 Has the transmission/clutch been repaired before or components installed?
    - Check the vehicle service record. Note any repairs.

## DIAGNOSIS AND TESTING (Continued)

### Check Fluid Level and Condition

 **CAUTION:** The vehicle should not be driven if the fluid level is low or damage may occur.

 **CAUTION:** Excessive temperatures may break down the transmission lubricant. If there is reason to believe that the transmission has been subjected to temperatures exceeding 135°C (275°F), change the lubricant immediately.

An incorrect level may affect the transmission operation and can result in transmission damage. To correctly check and add fluid to the transmission, refer to Specifications in this section.

A low fluid level can result in poor transmission shifting, engagement or damage. It can also indicate a leak in one of the transmission seals or gaskets.

1. Check the fluid condition.
  - Observe the color and the odor of the fluid. Allow the fluid to drip onto a white cloth and examine the stain. Check the fluid for contamination or metal particles.
    - Fluid should appear reddish in color.

### Evaluation of Clutch Hydraulic System

1. Verify that the clutch hydraulic fluid reservoir is filled to the correct level.
  - If the fluid level is correct, proceed to clutch check.
  - If the fluid level is low, add fluid as necessary. Check the clutch hydraulic system for leaks and repair as necessary.

### Evaluation of the Clutch

1. Depress and release the clutch pedal slowly to check if the pedal is binding. Make sure the clutch pedal can be fully depressed and is not restricted by the floor mat.
2. Measure the clutch reserve. [GO to Pinpoint Test C.](#)

3. With the engine idling, the parking brake on and the clutch pedal up, gently move the gearshift lever forward into and out of REVERSE gear, until gear clash can be heard. Depress the clutch pedal slowly.
  - If the gears cease to clash (full disengage at 1 to 1.5 inch from the floor), then hold the pedal at the point of disengagement and increase engine to 4,000 rpm. The clutch should remain disengaged, clutch OK.
  - Any concerns indicate a worn or damaged clutch. Repair as necessary.
4. With the engine idling, move the gearshift lever into 4th gear. Increase the rpm to 2,000 and slowly release the clutch pedal.
  - If the engine stalls, clutch is OK.
  - If the engine does not stall, clutch slipping. Repair as necessary.
5. Compare the clutch evaluation results with the following table. The following list of conditions are typical faults into which clutch concerns will fall.

### Symptom Chart

Conditions/Sources	Action
<ul style="list-style-type: none"> <li>• <b>Clutch Slippage</b> <ul style="list-style-type: none"> <li>— Clutch pedal reserve</li> <li>— Diaphragm springs</li> <li>— Clutch pressure plate</li> <li>— Clutch disc facing</li> <li>— Hardened or oiled clutch disc facing surface</li> <li>— Flywheel</li> </ul> </li> </ul>	<ul style="list-style-type: none"> <li>• <a href="#">GO to Pinpoint Test A.</a></li> </ul>
<ul style="list-style-type: none"> <li>• <b>Clutch Chatter or Shudder</b> <ul style="list-style-type: none"> <li>— Engine mounts</li> <li>— Oil on clutch disc facing</li> <li>— Diaphragm springs</li> <li>— Clutch pressure plate</li> <li>— Clutch disc facing</li> <li>— Flywheel</li> <li>— Clutch disc</li> </ul> </li> </ul>	<ul style="list-style-type: none"> <li>• <a href="#">GO to Pinpoint Test B.</a></li> </ul>

**DIAGNOSIS AND TESTING (Continued)****Symptom Chart (Continued)**

Conditions/Sources	Action
<ul style="list-style-type: none"> <li>• <b>Clutch Pedal Feels Spongy or Has Excessive Travel. Clutch Will Not Disengage</b> <ul style="list-style-type: none"> <li>— Insufficient clutch fluid</li> <li>— Air in hydraulic system</li> <li>— Clutch pedal reserve</li> <li>— Diaphragm springs</li> <li>— Clutch disc</li> <li>— Clutch disc splines</li> <li>— Oil on facing</li> </ul> </li> </ul>	<ul style="list-style-type: none"> <li>• <b>GO to Pinpoint Test C.</b></li> </ul>
<ul style="list-style-type: none"> <li>• <b>Clutch Drag, Also Hard to Shift</b> <ul style="list-style-type: none"> <li>— Insufficient clutch fluid</li> <li>— Air in hydraulic system</li> <li>— Clutch pedal reserve</li> <li>— Diaphragm springs</li> <li>— Clutch disc</li> <li>— Transmission concern</li> </ul> </li> </ul>	<ul style="list-style-type: none"> <li>• <b>GO to Pinpoint Test D.</b></li> </ul>
<ul style="list-style-type: none"> <li>• <b>Clutch Pedal Pulsation</b> <ul style="list-style-type: none"> <li>— Clutch and brake pedal pivot shaft not correctly lubricated</li> <li>— Flywheel</li> <li>— Worn springs in pressure plate</li> </ul> </li> </ul>	<ul style="list-style-type: none"> <li>• <b>GO to Pinpoint Test E.</b></li> </ul>
<ul style="list-style-type: none"> <li>• <b>Clutch-Related Vibrations</b> <ul style="list-style-type: none"> <li>— Engine component grounding against frame</li> <li>— Accessory drive belt</li> <li>— Flywheel bolts</li> <li>— Flywheel</li> <li>— Imbalanced clutch pressure plate</li> </ul> </li> </ul>	<ul style="list-style-type: none"> <li>• <b>GO to Pinpoint Test F.</b></li> </ul>
<ul style="list-style-type: none"> <li>• <b>Excessive Noise</b> <ul style="list-style-type: none"> <li>— Clutch pedal reserve</li> <li>— Clutch slave cylinder</li> <li>— Pilot bearing</li> <li>— Excessive crankshaft end play</li> </ul> </li> </ul>	<ul style="list-style-type: none"> <li>• <b>GO to Pinpoint Test G.</b></li> </ul>

**Symptom Chart (Continued)**

Conditions/Sources	Action
<ul style="list-style-type: none"> <li>• <b>Clutch System Leakage</b> <ul style="list-style-type: none"> <li>— Clutch master cylinder</li> <li>— Clutch slave cylinder</li> <li>— Clutch hydraulic tubes</li> </ul> </li> </ul>	<ul style="list-style-type: none"> <li>• <b>GO to Pinpoint Test C.</b></li> </ul>
<p>If the clutch was the concern, REPAIR the clutch system. TEST the system for normal operation.</p>	

**Inspect the Gearshift Mechanism**

1. Inspect the gearshift mechanism for:
  - signs of damage.
  - missing or loose fasteners.
  - binding.
2. Repair any concerns as necessary.

**Evaluation of the Transmission**

1. During the road test, use the following driving methods to diagnose the concern.
  - Start the engine.
  - Evaluate the noise in NEUTRAL while the vehicle is parked.
    - Check whether the noise is present with the clutch fully disengaged (pedal fully depressed). Check to see if the pedal pulsates abnormally (for clutch diaphragm finger run out).
    - Check whether the noise is present with the gearshift in the NEUTRAL position and the clutch fully engaged (foot off pedal). With the parking brake engaged, move the gearshift towards the 1st gear position. Apply very slight pressure and note if the gear noise level is reduced. (for gear rollover noise).
    - With the clutch fully engaged (foot off pedal) check whether the noise is present as the engine speed is raised. If the noise reduces, note the engine speed at which this occurs.
  - Listen for any change in noise while depressing and releasing the clutch pedal.
  - Listen for any change in noise while changing the engine rpm.

**DIAGNOSIS AND TESTING (Continued)**

- Drive the vehicle and shift through all of the gear ranges, including REVERSE. Listen for any change in noise in a particular gear.
  - Drive the vehicle in the gear in which the noise is most noticeable. Depress the clutch pedal and leave the gear engaged. Listen for any change in noise.
  - Drive the vehicle in the gear in which the noise is most noticeable. Depress the clutch pedal and shift the transmission into NEUTRAL. Release the clutch pedal and allow the vehicle to coast.
- Compare the noise to another vehicle. Make sure the transmissions are the same.
2. Compare the road test results with the following symptom chart. It is a list of conditions that are typical faults into which the transmission will fall:  
GO to [Symptom Chart — Transmission Operation](#) or GO to [Symptom Chart — Noise, Vibration and Harshness \(NVH\)](#) in this section.

**Symptom Chart — Transmission Operation****Symptom Chart — Transmission Operation**

Condition	Possible Sources	Action
<ul style="list-style-type: none"> <li>• Transmission difficult to shift</li> </ul>	<ul style="list-style-type: none"> <li>• Lubricant</li> <li>• Internal shift mechanism</li> <li>• Sliding gears, synchronizers</li> <li>• Housings, shaft</li> <li>• Loose pressure plate to flywheel bolts</li> </ul>	<ul style="list-style-type: none"> <li>• ADD or DRAIN and FILL with specified lubricant.</li> <li>• CHECK the internal shift mechanism for smooth operation. REPAIR or INSTALL a new mechanism as necessary.</li> <li>• CHECK for free movement of gears and synchronizers. REPAIR or INSTALL new components as necessary.</li> <li>• CHECK for binding condition between the input shaft and the engine crankshaft pilot bearing or bushing. REPAIR or INSTALL new components as necessary. Refer to the appropriate section in Group 308 for the procedure.</li> <li>• CHECK for loose bolts at the pressure plate. INSTALL new components as necessary. REFER to Section 308-01.</li> </ul>
<ul style="list-style-type: none"> <li>• Transmission will not shift — gearshift lever moves</li> </ul>	<ul style="list-style-type: none"> <li>• Gearshift lever damaged</li> <li>• Damaged or worn offset lever, shift plate or selector arm. Loose shift rail bushings</li> </ul>	<ul style="list-style-type: none"> <li>• INSTALL a new gearshift lever.</li> <li>• CHECK the internal shift components. INSTALL new component as necessary.</li> </ul>



**DIAGNOSIS AND TESTING (Continued)****Symptom Chart — Transmission Operation (Continued)**

Condition	Possible Sources	Action
<ul style="list-style-type: none"> <li>Gears clash when shifting from one forward gear to another</li> </ul>	<ul style="list-style-type: none"> <li>Pilot bearing</li> <li>Gear teeth and/or synchronizer</li> <li>Damaged shift forks or worn shift fork inserts</li> </ul>	<ul style="list-style-type: none"> <li>CHECK for a binding condition between the input shaft and the engine crankshaft pilot bearing. INSTALL new components as necessary. REFER to Section 308-01.</li> <li>REPAIR or INSTALL new components as necessary. Refer to the appropriate section in Group 308 for the procedure.</li> <li>INSPECT for wear or damage. INSTALL new components as necessary. Refer to the appropriate section in Group 308 for the procedure.</li> </ul>
<ul style="list-style-type: none"> <li>Transmission jumps out of gear</li> </ul>	<ul style="list-style-type: none"> <li>Transmission range selector lever boot</li> <li>Transmission-to-engine mounting bolts</li> <li>Crankshaft pilot bearing</li> <li>Internal damage</li> <li>Gear teeth</li> </ul>	<ul style="list-style-type: none"> <li>INSTALL a new boot if exceptionally stiff. Refer to the appropriate section in Group 308 for the procedure.</li> <li>TIGHTEN the bolts to specification.</li> <li>INSTALL a new bearing.</li> <li>INSPECT the synchronizer sleeves for free movement on their hubs. INSPECT the synchronizer blocking rings for widened index slots, rounded clutch teeth and smooth internal surface. CHECK countershaft cluster gear for excessive end play. CHECK shift forks for worn or loose mounting on shift rails. INSPECT the synchronizer sliding sleeve and the gear clutch teeth for wear or damage. REPAIR or INSTALL a new component as necessary.</li> <li>If worn or damaged, INSTALL new gears. Refer to the appropriate section in Group 308 for the procedure.</li> </ul>

**DIAGNOSIS AND TESTING (Continued)****Symptom Chart — Transmission Operation (Continued)**

Condition	Possible Sources	Action
<ul style="list-style-type: none"> <li>Transmission will not shift into one gear — all others OK</li> </ul>	<ul style="list-style-type: none"> <li>Manual shift linkage</li> <li>Backup switch ball</li> <li>Internal components</li> </ul>	<ul style="list-style-type: none"> <li>REPAIR or INSTALL new components as necessary.</li> <li>If REVERSE is the problem, CHECK reverse lamp switch for ball frozen in extended position.</li> <li>INSPECT the shift rail and fork system, synchronizer system and the gear clutch teeth for restricted travel. REPAIR or INSTALL new components as necessary.</li> </ul>
<ul style="list-style-type: none"> <li>Transmission is locked in one gear and cannot be shifted out of that gear</li> </ul>	<ul style="list-style-type: none"> <li>Internal components</li> <li>Fork on rail, offset lever or shift rail</li> </ul>	<ul style="list-style-type: none"> <li>INSPECT the problem gears, shift rails, forks and the synchronizer for wear or damage. REPAIR as necessary. Refer to the appropriate section in Group 308 for the procedure.</li> <li>CHECK the shift rail interlock system. REPAIR as necessary. Refer to the appropriate section in Group 308 for the procedure.</li> </ul>
<ul style="list-style-type: none"> <li>Transmission leaks</li> </ul>	<ul style="list-style-type: none"> <li>Lubricant</li> <li>Other component leaking</li> <li>False report</li> <li>Internal components</li> <li>Fill and drain plugs</li> </ul>	<ul style="list-style-type: none"> <li>CHECK the level and type.</li> <li>IDENTIFY leaking fluid as engine, power steering or transmission fluid. REPAIR as necessary.</li> <li>REMOVE all traces of lube on the exposed transmission surfaces. CHECK the vent for free breathing. OPERATE the transmission and INSPECT for new leakage. REPAIR as necessary. Refer to the appropriate section in Group 308 for the procedure.</li> <li>INSPECT for leaks at the input shaft bearing retainer seal and the shift rail expansion plug. Refer to the appropriate section in Group 308 for the procedure. INSPECT for leaks at the top cover gasket. INSPECT the case for sand holes or cracks. REPAIR or INSTALL a new case as necessary. Refer to the appropriate section in Group 308 for the procedure.</li> <li>CHECK fill and drain plugs and bore threads. REPAIR as necessary. TIGHTEN plugs to specified torque value. Refer to the appropriate section in Group 308 for the procedure.</li> </ul>

**DIAGNOSIS AND TESTING (Continued)****Symptom Chart — Transmission Operation (Continued)**

Condition	Possible Sources	Action
<ul style="list-style-type: none"> <li>• Bearing failure</li> </ul>	<ul style="list-style-type: none"> <li>• Other part failure</li> <li>• Raceways or rollers</li> <li>• Lubricant</li> <li>• Towing vehicle further than 80 km (50 mi) with driveshaft installed. Mainshaft tapered bearings and needle caged bearings are especially susceptible to damage</li> <li>• Vibration break-up of retainer and brinelling of races</li> <li>• Bearing(s)</li> <li>• Shafts or bore</li> <li>• Overloading of vehicle</li> <li>• Incorrect preload</li> <li>• Input shaft oil dam</li> <li>• Oil baffle in the input bearing shim pack</li> </ul>	<ul style="list-style-type: none"> <li>• REMOVE, DISASSEMBLE and CLEAN the transmission. Inspect for damaged parts and install new components as necessary. (Note: RESET the bearing preload if any new tapered bearings are installed.) Refer to the appropriate section in Group 308 for the procedure.</li> <li>• DETERMINE the cause of vibration and CORRECT. Otherwise, PROCEED as above.</li> <li>• INSTALL new components as necessary and VERIFY the oil dam installation is correct. Refer to the appropriate section in Group 308 for the procedure. CHECK for correct installation of the snap ring on the mainshaft next to the oil dam.</li> <li>• INSTALL a new oil baffle, making sure it is not damaged during assembly. Refer to the appropriate section in Group 308 for the procedure.</li> </ul>

**DIAGNOSIS AND TESTING (Continued)****Symptom Chart — Noise, Vibration and Harshness (NVH)****Symptom Chart — Noise, Vibration and Harshness (NVH)**

**NOTE:** Noise, vibration and harshness (NVH) symptoms should be identified using the diagnostic tools that are available. For a list of these tools, an explanation of their uses and a glossary of common terms, refer to Section 100-04. Since it is possible any one of multiple systems may be the cause of a symptom, it may be necessary to use a process of elimination type of diagnostic approach to pinpoint the responsible system. If this is not the causal system for the symptom, refer back to Section 100-04 for the next likely system and continue diagnosis.

<b>Condition</b>	<b>Possible Sources</b>	<b>Action</b>
<ul style="list-style-type: none"> <li>Excessive noise</li> </ul>	<ul style="list-style-type: none"> <li>Clutch disc damper damaged</li> <li>Transmission input shaft pilot bearing worn or damaged</li> <li>Crankshaft end play excessive</li> <li>Release bearing worn or damaged</li> </ul>	<ul style="list-style-type: none"> <li>REMOVE the clutch disc and pressure plate. REFER to Section 308-01. INSPECT the clutch disc for damage. INSPECT the transmission input shaft pilot bearing for wear and damage. REFER to Pilot Bearing Check in this section. CHECK the crankshaft end play. Refer to the appropriate section in Group 303 for the procedure. CHECK the clutch release hub and bearing, and guide tube for wear and damage. REPAIR all components as necessary. TEST the system for normal operation.</li> </ul>
<ul style="list-style-type: none"> <li>Clutch rattling noise — occurs with clutch engaged, noise changes/disappears with clutch pedal depressed</li> </ul>	<ul style="list-style-type: none"> <li>Flywheel bolts, clutch housing bolts or clutch pressure plate bolts loose</li> </ul>	<ul style="list-style-type: none"> <li>TIGHTEN the bolts to specifications. CHECK the bolts for damage. REFER to Section 308-01.</li> </ul>
<ul style="list-style-type: none"> <li>Clutch squeaking noise — noise is heard when the clutch is operated. Vehicle moves slowly or creeps when the clutch is disengaged. Can also be difficult to shift into 1st and REVERSE gears</li> </ul>	<ul style="list-style-type: none"> <li>Pilot bearing seized or damaged</li> </ul>	<ul style="list-style-type: none"> <li>INSTALL a new pilot bearing. REFER to Section 308-01.</li> </ul>
<ul style="list-style-type: none"> <li>Clutch squeaking noise — occurs with clutch pedal depressed/released</li> </ul>	<ul style="list-style-type: none"> <li>Worn clutch pedal shaft or bushings</li> </ul>	<ul style="list-style-type: none"> <li>INSPECT the clutch pedal for wear or damage. REPAIR as necessary. REFER to Section 308-02.</li> </ul>
<ul style="list-style-type: none"> <li>Clutch whirring/rattle noise — occurs when clutch pedal is depressed</li> </ul>	<ul style="list-style-type: none"> <li>Worn, damaged or misaligned clutch release bearing</li> </ul>	<ul style="list-style-type: none"> <li>INSTALL a new clutch release bearing. REFER to Section 308-01.</li> </ul>
<ul style="list-style-type: none"> <li>Clutch grating/grinding noise — occurs when clutch pedal is depressed</li> </ul>	<ul style="list-style-type: none"> <li>Clutch pressure plate fingers bent or worn</li> <li>Contact surface of clutch release bearing worn or damaged</li> </ul>	<ul style="list-style-type: none"> <li>INSPECT the clutch pressure plate release fingers. INSTALL a new pressure plate as necessary. REFER to Section 308-01.</li> <li>INSTALL a new clutch release bearing. REFER to Section 308-01.</li> </ul>

**DIAGNOSIS AND TESTING (Continued)****Symptom Chart — Noise, Vibration and Harshness (NVH) (Continued)**

Condition	Possible Sources	Action
<ul style="list-style-type: none"> <li>Clutch chatter — a small amount of noise when clutch pedal is released at initial take-off</li> </ul>	<ul style="list-style-type: none"> <li>Clutch engagement</li> </ul>	<ul style="list-style-type: none"> <li>Acceptable operating condition.</li> </ul>
<ul style="list-style-type: none"> <li>Clutch chatter/grabs — in some cases a shudder is felt. Occurs with clutch pedal depressed/released</li> </ul>	<ul style="list-style-type: none"> <li>Damaged or worn powertrain/driveline mounts</li> <li>Binding or dragging plunger of the clutch master cylinder or slave cylinder</li> <li>Grease or oil on the clutch disc facing</li> <li>Clutch disc surface glazed or damaged</li> <li>Damaged or worn clutch pressure plate</li> <li>Flywheel surface damaged or glazed</li> </ul>	<ul style="list-style-type: none"> <li>INSPECT the powertrain/drivetrain mounts. INSTALL new mounts as necessary. Refer to the appropriate section in Group 303 for the procedure.</li> <li>CHECK the master and slave cylinder operation. INSPECT the components for damage or wear. INSTALL a new master or slave cylinder as necessary. REFER to Section 308-02.</li> <li>CHECK the input shaft seal and rear main oil seal. REPAIR as necessary. INSTALL a new clutch disc. REFER to Section 308-01.</li> <li>INSPECT the clutch disc surface for a glazed, hardened or damage condition. CARRY OUT a disc check. INSTALL a new clutch disc as necessary. REFER to Section 308-01.</li> <li>INSPECT the clutch pressure plate for wear or damage. INSTALL a new clutch pressure plate as necessary. REFER to Section 308-01.</li> <li>INSPECT the flywheel for damage or wear. CARRY OUT a flywheel runout check. INSTALL a new flywheel as necessary. Refer to the appropriate section in Group 303 for the procedure.</li> </ul>
<ul style="list-style-type: none"> <li>Clutch chatter noise — noise when clutch pedal is released at initial take-off. Clutch is hard to engage and disengage</li> </ul>	<ul style="list-style-type: none"> <li>Pilot bearing worn, damaged or not correctly aligned in bore</li> </ul>	<ul style="list-style-type: none"> <li>INSPECT the clutch pressure plate release fingers for uneven wear, clutch components burnt or a seized pilot bearing. INSTALL a new pilot bearing as necessary. REFER to Section 308-01.</li> </ul>
<ul style="list-style-type: none"> <li>Clutch chatter — a small amount of noise when the clutch is released at initial take-off. Occurs in 1st and/or REVERSE gear with the transmission at operating temperature (5.4L engines only)</li> </ul>	<ul style="list-style-type: none"> <li>Clutch engagement</li> </ul>	<ul style="list-style-type: none"> <li>Acceptable operating condition. Noise caused by the material used in the clutch disc.</li> </ul>

**DIAGNOSIS AND TESTING (Continued)****Symptom Chart — Noise, Vibration and Harshness (NVH) (Continued)**

Condition	Possible Sources	Action
<ul style="list-style-type: none"> <li>Clutch hiss — a small amount of noise during initial engagement of the clutch in 1st or REVERSE gear (5.4L engines only)</li> </ul>	<ul style="list-style-type: none"> <li>Clutch engagement</li> </ul>	<ul style="list-style-type: none"> <li>Acceptable operating condition. Noise caused by the clutch disc contacting the pressure plate and flywheel surfaces.</li> </ul>
<ul style="list-style-type: none"> <li>Transmission rattle noise — noise occurs at 1st and 2nd gear on light acceleration (5.4L engines only)</li> </ul>	<ul style="list-style-type: none"> <li>Gear engagement</li> </ul>	<ul style="list-style-type: none"> <li>Acceptable operating condition. Caused by the contact pattern of these gears.</li> </ul>
<ul style="list-style-type: none"> <li>Transmission rattling/clattering noise — occurs in NEUTRAL or in gear, at idle</li> </ul>	<ul style="list-style-type: none"> <li>Incorrect fluid level or fluid quality</li> </ul>	<ul style="list-style-type: none"> <li>CHECK that the transmission is filled to the correct level and with the specified fluid. REFER to Section 307-01 for the fluid type.</li> </ul>
<ul style="list-style-type: none"> <li>Transmission rattling/clattering noise — noise at idle in NEUTRAL</li> </ul>	<ul style="list-style-type: none"> <li>Worn or rough reverse idler gear</li> <li>Excessive backlash in gears</li> <li>Worn countershaft gears</li> </ul>	<ul style="list-style-type: none"> <li>CHECK the reverse idler gear. REPAIR as necessary. Refer to the appropriate section in Group 308 for the procedure.</li> <li>CHECK the gear backlash. ADJUST as necessary. Refer to the appropriate section in Group 308 for the procedure.</li> <li>REPAIR as necessary. Refer to the appropriate section in Group 308 for the procedure.</li> </ul>
<ul style="list-style-type: none"> <li>Transmission whine — a mild whine at extreme speeds or high rpm</li> </ul>	<ul style="list-style-type: none"> <li>Rotating gears/geartrain</li> </ul>	<ul style="list-style-type: none"> <li>Acceptable noise.</li> </ul>
<ul style="list-style-type: none"> <li>Transmission whine — a high pitched whine, also described as a squeal</li> </ul>	<ul style="list-style-type: none"> <li>Transmission gears are worn (high mileage vehicle)</li> <li>Mismatched gear sets</li> <li>Damaged or worn transmission bearing</li> </ul>	<ul style="list-style-type: none"> <li>Result of normal gear wear. REPAIR as necessary. Refer to the appropriate section in Group 308 for the procedure.</li> <li>INSPECT the gear sets for an uneven wear pattern on the face of the gear teeth. REPAIR as necessary. Refer to the appropriate section in Group 308 for the procedure.</li> <li>INSPECT the transmission bearings. INSTALL new bearings as necessary. Refer to the appropriate section in Group 308 for the procedure.</li> </ul>
<ul style="list-style-type: none"> <li>Transmission growling/humming — noise occurs in the forward gears. The noise is more prominent when the gear is loaded. The problem gear can be located as the noise occurs in a specific gear position</li> </ul>	<ul style="list-style-type: none"> <li>Gear is cracked, chipped or rough</li> </ul>	<ul style="list-style-type: none"> <li>INSPECT the transmission gears for damage or wear. INSTALL new gears as necessary. Refer to the appropriate section in Group 308 for the procedure.</li> </ul>

**DIAGNOSIS AND TESTING (Continued)****Symptom Chart — Noise, Vibration and Harshness (NVH) (Continued)**

Condition	Possible Sources	Action
<ul style="list-style-type: none"> <li>Transmission hissing — noise in NEUTRAL or in forward gears. As bearings wear or break up, the noise changes to a thumping noise</li> </ul>	<ul style="list-style-type: none"> <li>Damaged or worn bearings</li> </ul>	<ul style="list-style-type: none"> <li>INSPECT the transmission bearings. INSTALL new bearings as necessary. Refer to the appropriate section in Group 308 for the procedure.</li> </ul>
<ul style="list-style-type: none"> <li>Transmission knocking/thudding — noise at low speeds in forward gears</li> </ul>	<ul style="list-style-type: none"> <li>Bearings with damaged balls or rollers or with pitted and spalled races</li> </ul>	<ul style="list-style-type: none"> <li>INSPECT the transmission bearings. INSTALL new bearings as necessary. Refer to the appropriate section in Group 308 for the procedure.</li> </ul>
<ul style="list-style-type: none"> <li>Transmission rumble/growl — noise at higher speeds in forward gears, more pronounced in a coast/deceleration condition</li> </ul>	<ul style="list-style-type: none"> <li>Incorrect driveline angle</li> <li>Driveshaft out of balance or damaged</li> </ul>	<ul style="list-style-type: none"> <li>CHECK the driveline angle. REPAIR as necessary. REFER to Section 205-00. Refer to the appropriate section in Group 308 for the procedure.</li> <li>CHECK the driveshaft for damage, missing balance weights or undercoating. REFER to the driveshaft runout and balance test in Section 205-00.</li> </ul>
<ul style="list-style-type: none"> <li>Transmission rumble/growl — noise at all speeds in forward gears, more pronounced in a heavy acceleration condition</li> </ul>	<ul style="list-style-type: none"> <li>Damaged or worn transmission bearing or gears (high mileage vehicles)</li> </ul>	<ul style="list-style-type: none"> <li>CHECK transmission fluid for excessive metal particles. REPAIR as necessary.</li> </ul>

**Pinpoint Tests****Pinpoint Test A: Clutch Slippage****Normal Operation**

The clutch is designed to transfer the power from the engine to the transmission, which may be either stationary (starting) or rotating at a different speed (upshifting or downshifting). The clutch is functioning correctly when both the engine and transmission are rotating at the same speed with the clutch engaged. Clutch pedal movement is transmitted by fluid pressure, which actuates the clutch release hub and bearing. The clutch release hub and bearing pushes on the spring center towards the flywheel. The diaphragm spring pivots at the fulcrum, relieving the load on the clutch pressure plate. Steel spring straps riveted in the clutch pressure plate cover pull the clutch pressure plate from the clutch disc, disengaging the engine torque from the transmission.

**This pinpoint test is intended to diagnose the following:**

- Clutch pedal
- Clutch hydraulic system
- Clutch disc
- Clutch pressure plate

**DIAGNOSIS AND TESTING (Continued)****PINPOINT TEST A: CLUTCH SLIPPAGE**

Test Step		Result / Action to Take
<b>A1</b>	<b>INSPECT THE CLUTCH PEDAL</b>	<b>Yes</b> GO to <b>A2</b> . <b>No</b> INSPECT the clutch pedal. REFER to Section 308-02.
	<ul style="list-style-type: none"> <li>Ignition OFF.</li> <li>Block the wheels and apply the parking brake.</li> <li>Depress and slowly release the clutch pedal.</li> <li><b>Does the clutch pedal release without binding?</b></li> </ul>	
<b>A2</b>	<b>CHECK THE HYDRAULIC SYSTEM</b>	<b>Yes</b> INSTALL a new clutch master cylinder. REFER to Section 308-02. <b>No</b> GO to <b>A3</b> .
	<ul style="list-style-type: none"> <li>Ignition OFF.</li> <li>Depress and release the clutch pedal.</li> <li><b>Is there residual hydraulic pressure at the bleed screw?</b></li> </ul>	
<b>A3</b>	<b>CARRY OUT A STALL TEST</b>	<b>Yes</b> The clutch is not slipping. VERIFY the customer concern. <b>No</b> INSPECT the clutch components for damage.
	<ul style="list-style-type: none"> <li>Start the engine.</li> <li>Block the wheels and apply the parking brake.</li> <li>Place the transmission in 4th gear.</li> <li>Increase the engine speed to 2000 rpm and slowly release the clutch pedal.</li> <li><b>Does the engine stall within 5 seconds?</b></li> </ul>	

**Pinpoint Test B: Clutch Chatter or Shudder****Normal Operation**

The clutch is designed to transfer the power from the engine to the transmission, which may be either stationary (starting) or rotating at a different speed (upshifting or downshifting). The clutch is functioning correctly when both the engine and transmission are rotating at the same speed with the clutch engaged. Clutch pedal movement is transmitted by fluid pressure, which actuates the clutch release hub and bearing. The clutch release hub and bearing pushes on the spring center towards the flywheel. The diaphragm spring pivots at the fulcrum, relieving the load on the clutch pressure plate. Steel spring straps riveted in the clutch pressure plate cover pull the clutch pressure plate from the clutch disc, disengaging the engine torque from the transmission.

**This pinpoint test is intended to diagnose the following:**

- Engine or transmission mounts
- Clutch disc
- Clutch pressure plate
- Flywheel
- Pilot bearing
- Input shaft

**PINPOINT TEST B: CLUTCH CHATTER OR SHUDDER**

Test Step		Result / Action to Take
<b>B1</b>	<b>CHECK THE ENGINE OR TRANSMISSION MOUNTS</b>	<b>Yes</b> TIGHTEN or INSTALL new engine mounts or transmission mounts as necessary. TEST the system for normal operation. <b>No</b> GO to <b>B2</b> .
	<ul style="list-style-type: none"> <li>Inspect all the engine and transmission mounts for loose fasteners or damage.</li> <li><b>Are any of the engine or transmission mounts loose or damaged?</b></li> </ul>	

(Continued)

**DIAGNOSIS AND TESTING (Continued)****PINPOINT TEST B: CLUTCH CHATTER OR SHUDDER (Continued)**

Test Step		Result / Action to Take
<b>B2</b>	<b>INSPECT THE PRESSURE PLATE BOLTS</b>	<p><b>Yes</b> TIGHTEN or INSTALL new bolts as necessary. REFER to Section 308-01. TEST the system for normal operation.</p> <p><b>No</b> GO to <b>B3</b>.</p>
	<ul style="list-style-type: none"> <li>Inspect the pressure plate-to-flywheel bolts.</li> <li><b>Are any of the pressure plate-to-flywheel bolts loose?</b></li> </ul>	
<b>B3</b>	<b>INSPECT THE PRESSURE PLATE</b>	<p><b>Yes</b> INSTALL a new clutch pressure plate. REFER to Section 308-01. TEST the system for normal operation.</p> <p><b>No</b> GO to <b>B4</b>.</p>
	<ul style="list-style-type: none"> <li>Remove the clutch pressure plate. Refer to Section 308-01.</li> <li>Inspect the clutch pressure plate. Refer to Clutch Pressure Plate Check in this section.</li> <li><b>Are any signs of damage present on the clutch pressure plate?</b></li> </ul>	
<b>B4</b>	<b>CHECK THE CLUTCH DISC</b>	<p><b>Yes</b> GO to <b>B5</b>.</p> <p><b>No</b> INSTALL a new clutch disc. REFER to Section 308-01. TEST the system for normal operation.</p>
	<ul style="list-style-type: none"> <li>Carry out the clutch disc inspection procedure. Refer to Clutch Disc Check in this section.</li> <li><b>Is the clutch disc OK?</b></li> </ul>	
<b>B5</b>	<b>INSPECT THE FLYWHEEL</b>	<p><b>Yes</b> GO to <b>B6</b>.</p> <p><b>No</b> REPAIR or INSTALL a new flywheel as necessary. Refer to the appropriate section in Group 303 for the procedure. TEST the system for normal operation.</p>
	<ul style="list-style-type: none"> <li>Inspect the flywheel for damage and runout. Refer to Flywheel Runout Check in this section.</li> <li><b>Is the flywheel OK?</b></li> </ul>	
<b>B6</b>	<b>INSPECT THE PILOT BEARING</b>	<p><b>Yes</b> INSTALL a new pilot bearing. REFER to Section 308-01.</p> <p><b>No</b> GO to <b>B7</b>.</p>
	<ul style="list-style-type: none"> <li>Inspect the pilot bearing for wear or damage.</li> <li><b>Are there signs of wear or damage?</b></li> </ul>	
<b>B7</b>	<b>INSPECT THE INPUT SHAFT</b>	<p><b>Yes</b> INSTALL a new input shaft. Refer to the appropriate section in Group 308 for the procedure.</p> <p><b>No</b> VERIFY the customer concerns. GO to <a href="#">Symptom Chart</a> if necessary.</p>
	<ul style="list-style-type: none"> <li>Inspect the input shaft for signs of wear or damage.</li> <li><b>Are any signs of wear or damage present on the input shaft?</b></li> </ul>	

**DIAGNOSIS AND TESTING (Continued)**

**Pinpoint Test C: Clutch Pedal Feels Spongy or Has Excessive Travel. Clutch Will Not Disengage**

**Normal Operation**

The clutch is designed to transfer the power from the engine to the transmission, which may be either stationary (starting) or rotating at a different speed (upshifting or downshifting). The clutch is functioning correctly when both the engine and transmission are rotating at the same speed with the clutch engaged. Clutch pedal movement is transmitted by fluid pressure, which actuates the clutch release hub and bearing. The clutch release hub and bearing pushes on the spring center towards the flywheel. The diaphragm spring pivots at the fulcrum, relieving the load on the clutch pressure plate. Steel spring straps riveted in the clutch pressure plate cover pull the clutch pressure plate from the clutch disc, disengaging the engine torque from the transmission.

**This pinpoint test is intended to diagnose the following:**

- Internal operation
- Clutch pedal reserve
- Clutch slave cylinder travel
- Clutch disc
- Clutch pressure plate
- Clutch pedal free play

**PINPOINT TEST C: CLUTCH PEDAL FEELS SPONGY OR HAS EXCESSIVE TRAVEL. CLUTCH WILL NOT DISENGAGE**

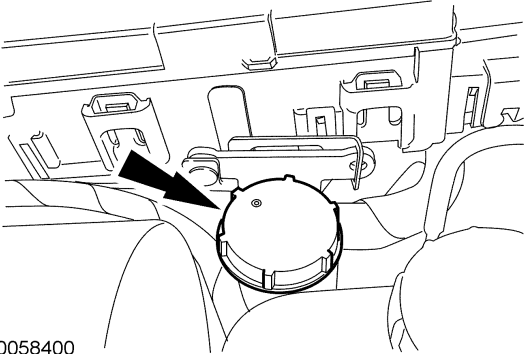
Test Step		Result / Action to Take
<b>C1</b>	<p><b>CHECK THE FLUID LEVEL</b></p> <ul style="list-style-type: none"> <li>• <b>NOTE:</b> Do not check the hydraulic system after the road test. Allow the vehicle to cool down before carrying out the clutch hydraulic system check.</li> <li>Remove the brake and clutch reservoir cap.</li> </ul>  <p>A0058400</p> <ul style="list-style-type: none"> <li>• Check the fluid level of the brake and clutch reservoir.</li> <li>• <b>Is the fluid level at or above the step mark?</b></li> </ul>	<p><b>Yes</b> INSTALL the reservoir cap. GO to <b>C2</b>.</p> <p><b>No</b> ADD brake fluid to the specified level. GO to <b>C2</b>.</p>
<b>C2</b>	<p><b>INSPECT THE HYDRAULIC SYSTEM FOR LEAKAGE</b></p> <ul style="list-style-type: none"> <li>• Check the reservoir and reservoir lines for leakage.</li> <li>• Check the master cylinder and hydraulic line for leakage.</li> <li>• Check the clutch slave cylinder and the hydraulic line connection for leakage.</li> <li>• <b>Are there any signs of leakage?</b></li> </ul>	<p><b>Yes</b> INSTALL new components as necessary. TEST the system for normal operation.</p> <p><b>No</b> GO to <b>C3</b>.</p>
<b>C3</b>	<p><b>CHECK INTERNAL OPERATION</b></p> <ul style="list-style-type: none"> <li>• Remove the reservoir cap.</li> <li>• Have an assistant slowly depress and release the clutch pedal.</li> <li>• On the down stroke, the fluid level should not increase by more than 1 mm (0.039 in).</li> <li>• <b>Does the fluid level increase more than 1 mm (0.039 in)?</b></li> </ul>	<p><b>Yes</b> INSTALL a new cylinder master cylinder assembly.</p> <p><b>No</b> GO to <b>C4</b>.</p>

(Continued)

**DIAGNOSIS AND TESTING (Continued)**

**PINPOINT TEST C: CLUTCH PEDAL FEELS SPONGY OR HAS EXCESSIVE TRAVEL. CLUTCH WILL NOT DISENGAGE (Continued)**

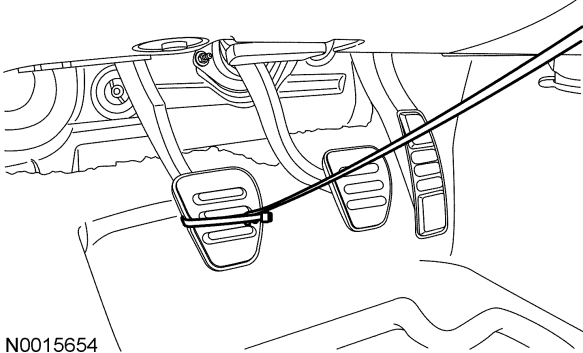
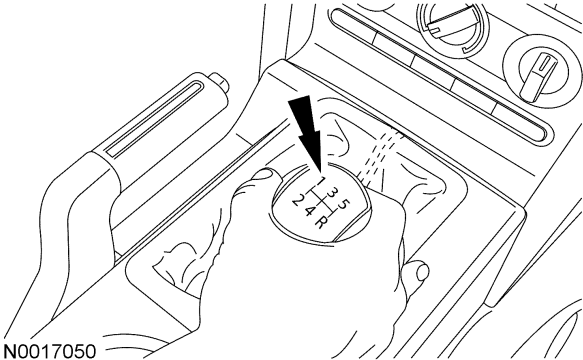
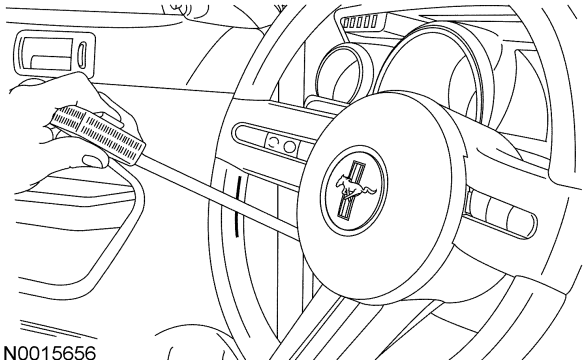
	Test Step	Result / Action to Take
C4	<b>CHECK THE CLUTCH PEDAL RESERVE</b>	
	<p><b>NOTE:</b> The clutch reserve is the distance between the clutch pedal when fully depressed and the position when the vehicle starts to move forward.</p> <ul style="list-style-type: none"> <li>• Park the vehicle on a level surface.</li> <li>• Check for obstructions behind clutch pedal.</li> <li>• Attach a cable tie to the lower clutch pedal.</li> </ul>  <p>N0015654</p> <ul style="list-style-type: none"> <li>• Attach a tape measure to the cable tie.</li> <li>• Depress the clutch fully and start the vehicle.</li> <li>• Shift the transmission into 1st gear.</li> </ul>  <p>N0017050</p> <ul style="list-style-type: none"> <li>• Use the seam on the steering wheel as a reference point.</li> </ul>  <p>N0015656</p>	

(Continued)

**DIAGNOSIS AND TESTING (Continued)****PINPOINT TEST C: CLUTCH PEDAL FEELS SPONGY OR HAS EXCESSIVE TRAVEL. CLUTCH WILL NOT DISENGAGE (Continued)**

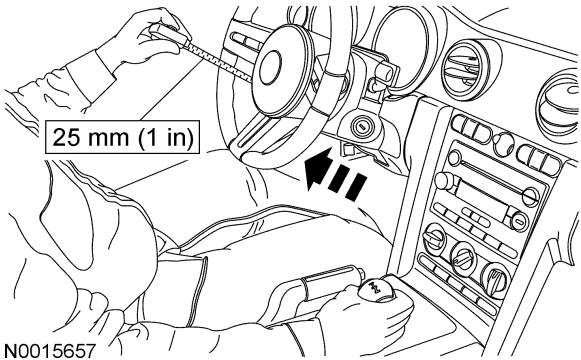
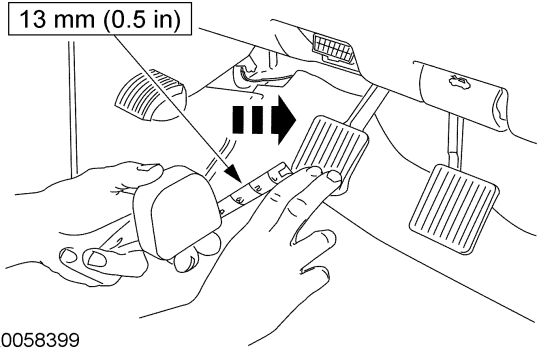
Test Step		Result / Action to Take
<b>C4</b>	<b>CHECK THE CLUTCH PEDAL RESERVE (Continued)</b>	
	<ul style="list-style-type: none"> <li>While observing the tape measure, slowly engage the clutch, noting when the vehicle starts to move forward.</li> </ul>  <p>N0015657</p> <ul style="list-style-type: none"> <li>Is the clutch pedal reserve greater than or equal to 25 mm (1 in)?</li> </ul>	<p><b>Yes</b> The clutch hydraulic system is OK. TEST the system for normal operation.</p> <p><b>No</b> GO to <b>C5</b>.</p>
<b>C5</b>	<b>CHECK THE CLUTCH PRESSURE PLATE</b>	
	<ul style="list-style-type: none"> <li>Remove the clutch pressure plate. Refer to Section 308-01.</li> <li>Inspect the clutch pressure plate for wear or runout. Refer to Clutch Pressure Plate Check in this section.</li> <li>Are there any signs of excessive wear or runout to the clutch pressure plate?</li> </ul>	<p><b>Yes</b> INSTALL a new clutch pressure plate. REFER to Section 308-01.</p> <p><b>No</b> GO to <b>C6</b>.</p>
<b>C6</b>	<b>INSPECT THE CLUTCH DISC</b>	
	<p><b>NOTE:</b> Vehicles equipped with a 4.0L engine use an inner floating damper design disc. When inspecting the disc, a rattle type noise can be heard. This is a normal condition.</p> <ul style="list-style-type: none"> <li>Carry out the clutch disc inspection procedure in this section.</li> <li>Is the clutch disc OK?</li> </ul>	<p><b>Yes</b> GO to <b>C7</b>.</p> <p><b>No</b> INSTALL a new clutch disc. REFER to Section 308-01. TEST the system for normal operation.</p>
<b>C7</b>	<b>CHECK CLUTCH PEDAL FREE PLAY</b>	
	<p><b>NOTE:</b> The clutch pedal free play is the distance between the clutch pedal when fully released and the position when slight resistance is felt on downward motion.</p> <ul style="list-style-type: none"> <li>Engine OFF.</li> <li>Attach a tape measure to the cable tie.</li> <li>While observing the tape measure, slowly push downward on the clutch pedal until a slight resistance is felt.</li> </ul>  <p>A0058399</p> <ul style="list-style-type: none"> <li>Is the clutch pedal free play less than 13 mm (0.5 in)?</li> </ul>	<p><b>Yes</b> The clutch hydraulic system is OK. TEST the system for normal operation.</p> <p><b>No</b> BLEED the clutch hydraulic system. REFER to Clutch System Bleeding in this section. TEST the system for normal operation.</p>

**DIAGNOSIS AND TESTING (Continued)****Pinpoint Test D: Clutch Drag, Also Hard to Shift****Normal Operation**

The clutch is designed to transfer the power from the engine to the transmission, which may be either stationary (starting) or rotating at a different speed (upshifting or downshifting). The clutch is functioning correctly when both the engine and transmission are rotating at the same speed with the clutch engaged. Clutch pedal movement is transmitted by fluid pressure, which actuates the clutch release hub and bearing. The clutch release hub and bearing pushes on the spring center towards the flywheel. The diaphragm spring pivots at the fulcrum, relieving the load on the clutch pressure plate. Steel spring straps riveted in the clutch pressure plate cover pull the clutch pressure plate from the clutch disc, disengaging the engine torque from the transmission.

**This pinpoint test is intended to diagnose the following:**

- Internal operation
- Clutch pedal reserve
- Clutch slave cylinder travel
- Clutch disc
- Clutch pressure plate
- Clutch pedal free play

**PINPOINT TEST D: CLUTCH DRAG, ALSO HARD TO SHIFT**

Test Step		Result / Action to Take
<b>D1</b>	<b>CHECK FLUID LEVEL</b>	<b>Yes</b> INSTALL the reservoir cap. GO to <b>D2</b> . <b>No</b> ADD brake fluid. GO to <b>D2</b> and CHECK for leaks. TEST the system for normal operation.
	<ul style="list-style-type: none"> <li>• Ignition OFF.</li> <li>• Remove the reservoir cap.</li> <li>• Inspect the fluid level in the brake and clutch reservoir.</li> <li>• <b>Is the fluid level at or above the step mark?</b></li> </ul>	
<b>D2</b>	<b>INSPECT THE CLUTCH HYDRAULIC SYSTEM FOR LEAKAGE</b>	<b>Yes</b> INSTALL new components as necessary. TEST the system for normal operation. <b>No</b> GO to <b>D3</b> .
	<ul style="list-style-type: none"> <li>• Inspect the clutch master cylinder and the hydraulic lines for leakage.</li> <li>• Inspect the reservoir and reservoir line for leakage.</li> <li>• Inspect the clutch slave cylinder and the hydraulic line connection for leakage.</li> <li>• <b>Are there any signs of leakage?</b></li> </ul>	
<b>D3</b>	<b>CHECK INTERNAL OPERATION</b>	<b>Yes</b> INSTALL a new cylinder master cylinder assembly. <b>No</b> GO to <b>D4</b> .
	<ul style="list-style-type: none"> <li>• Remove the reservoir cap.</li> <li>• Have an assistant slowly depress and release the clutch pedal.</li> <li>• On the down stroke, the fluid level should not increase by more than 1 mm (0.039 in).</li> <li>• <b>Does the fluid level increase more than 1 mm (0.039 in)?</b></li> </ul>	
<b>D4</b>	<b>CHECK THE CLUTCH PEDAL RESERVE</b>	
	<b>NOTE:</b> The clutch reserve is the distance between the clutch pedal when fully depressed and the position when the vehicle starts to move forward. <ul style="list-style-type: none"> <li>• Park the vehicle on a level surface.</li> <li>• Check for obstructions behind the clutch pedal. Check the carpet for correct installation. Remove the floor mat.</li> </ul>	

(Continued)

**DIAGNOSIS AND TESTING (Continued)**

**PINPOINT TEST D: CLUTCH DRAG, ALSO HARD TO SHIFT (Continued)**

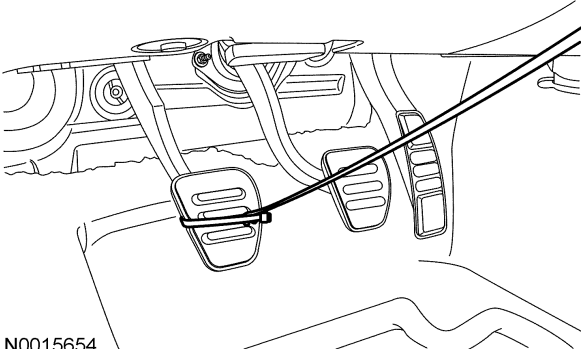
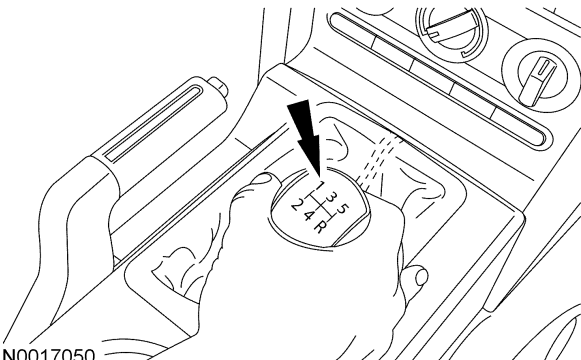
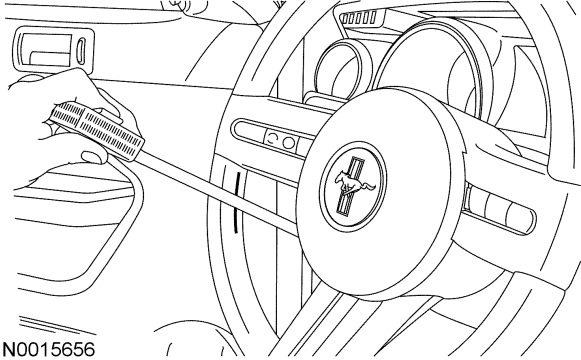
	Test Step	Result / Action to Take
<b>D4</b>	<b>CHECK THE CLUTCH PEDAL RESERVE (Continued)</b>	
<ul style="list-style-type: none"> <li>• Attach a cable tie to the lower clutch pedal.</li> </ul>  <p>N0015654</p>		
<ul style="list-style-type: none"> <li>• Attach a tape measure to the cable tie.</li> <li>• Depress the clutch fully and start the vehicle.</li> <li>• Shift the transmission into 1st gear.</li> </ul>  <p>N0017050</p>		
<ul style="list-style-type: none"> <li>• Use the seam on the steering wheel as a reference point.</li> </ul>  <p>N0015656</p>		

(Continued)

## DIAGNOSIS AND TESTING (Continued)

## PINPOINT TEST D: CLUTCH DRAG, ALSO HARD TO SHIFT (Continued)

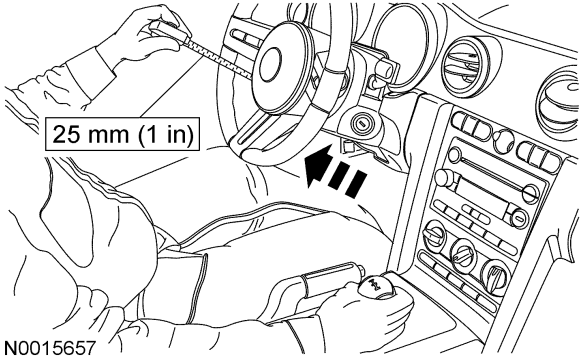
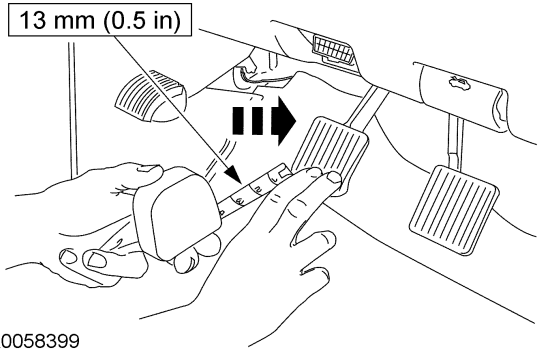
	Test Step	Result / Action to Take
D4	<p><b>CHECK THE CLUTCH PEDAL RESERVE (Continued)</b></p> <ul style="list-style-type: none"> <li>While observing the tape measure, slowly engage the clutch, noting when the vehicle starts to move forward.</li> </ul>  <ul style="list-style-type: none"> <li>Is the clutch pedal reserve greater than or equal to 25 mm (1 in)?</li> </ul>	<p><b>Yes</b> The clutch hydraulic system is OK. TEST the system for normal operation.</p> <p><b>No</b> GO to <b>D5</b>.</p>
D5	<p><b>CHECK THE CLUTCH PEDAL FREE PLAY</b></p> <p><b>NOTE:</b> The clutch pedal free play is the distance between the clutch pedal when fully released and the position when slight resistance is felt on downward motion.</p> <ul style="list-style-type: none"> <li>Engine OFF.</li> <li>Attach a tape measure to the cable tie.</li> <li>While observing the tape measure, slowly push downward on the clutch pedal until a slight resistance is felt.</li> </ul>  <ul style="list-style-type: none"> <li>Is the clutch pedal free play less than 13 mm (0.5 in)?</li> </ul>	<p><b>Yes</b> The clutch hydraulic system is OK. TEST the system for normal operation.</p> <p><b>No</b> GO to <b>D6</b>.</p>
D6	<p><b>CHECK THE CLUTCH PRESSURE PLATE</b></p> <ul style="list-style-type: none"> <li>Remove the clutch pressure plate. Refer to Section 308-01.</li> <li>Inspect the clutch pressure plate for wear or runout. Refer to Clutch Pressure Plate Check in this section.</li> <li>Are there any signs of excessive wear or runout to the clutch pressure plate?</li> </ul>	<p><b>Yes</b> INSTALL a new clutch pressure plate. REFER to Section 308-01.</p> <p><b>No</b> GO to <b>D7</b>.</p>
D7	<p><b>INSPECT THE CLUTCH DISC</b></p> <p><b>NOTE:</b> Vehicles equipped with a 4.0L engine use an inner floating damper design disc. When inspecting the disc, a rattle type noise can be heard. This is a normal operation.</p> <ul style="list-style-type: none"> <li>Carry out the clutch disc inspection procedure in this section.</li> <li>Is the clutch disc OK?</li> </ul>	<p><b>Yes</b> GO to <b>D8</b>.</p> <p><b>No</b> INSTALL a new clutch disc. REFER to Section 308-01. TEST the system for normal operation.</p>
D8	<p><b>INSPECT THE TRANSMISSION</b></p> <ul style="list-style-type: none"> <li>Remove the transmission.</li> <li>Disassemble the transmission. Refer to the appropriate section in Group 308 for the procedure.</li> </ul>	

(Continued)

**DIAGNOSIS AND TESTING (Continued)****PINPOINT TEST D: CLUTCH DRAG, ALSO HARD TO SHIFT (Continued)**

Test Step		Result / Action to Take
<b>D8</b>	<b>INSPECT THE TRANSMISSION (Continued)</b>	
	<ul style="list-style-type: none"> <li>• Carry out the following:               <ul style="list-style-type: none"> <li>— Inspect all the shift rails for excessive scuffing or wear.</li> <li>— Check the interlock pins on the shift rail.</li> <li>— Make sure the interlock bolts are tightened to specifications. Refer to the appropriate section in Group 308 for the procedure.</li> <li>— Inspect the shift pads for wear or cracking.</li> <li>— Inspect the shift forks for wear or damage.</li> <li>— Check the synchronizer rings of the affected gear for wear or damage.</li> <li>— Check the synchronizer hubs of the affected gear for wear or damage.</li> <li>— Inspect the clutching teeth of the affected gear.</li> </ul> </li> <li>• <b>Are there any internal components worn or damaged?</b></li> </ul>	<p><b>Yes</b> INSTALL new components or REPAIR as necessary. TEST the system for normal operation.</p> <p><b>No</b> ASSEMBLE and INSTALL the transmission. TEST the system for normal operation.</p>

**Pinpoint Test E: Clutch Pedal Pulsation****Normal Operation**

The clutch is designed to transfer the power from the engine to the transmission, which may be either stationary (starting) or rotating at a different speed (upshifting or downshifting). The clutch is functioning correctly when both the engine and transmission are rotating at the same speed with the clutch engaged. Clutch pedal movement is transmitted by fluid pressure, which actuates the clutch release hub and bearing. The clutch release hub and bearing pushes on the spring center towards the flywheel. The diaphragm spring pivots at the fulcrum, relieving the load on the clutch pressure plate. Steel spring straps riveted in the clutch pressure plate cover pull the clutch pressure plate from the clutch disc, disengaging the engine torque from the transmission.

**This pinpoint test is intended to diagnose the following:**

- Clutch disc
- Clutch pressure plate
- Flywheel

**PINPOINT TEST E: CLUTCH PEDAL PULSATION**

Test Step		Result / Action to Take
<b>E1</b>	<b>CHECK THE CLUTCH PEDAL PULSATION</b>	
	<ul style="list-style-type: none"> <li>• Start the engine.</li> <li>• With the transmission in NEUTRAL, slowly press the clutch pedal.</li> <li>• <b>Does the clutch pedal pulsate while being pressed?</b></li> </ul>	<p><b>Yes</b> GO to <b>E2</b>.</p> <p><b>No</b> VERIFY customer concern. GO to <a href="#">Symptom Chart</a> if necessary.</p>
<b>E2</b>	<b>INSPECT THE PRESSURE PLATE BOLTS</b>	
	<ul style="list-style-type: none"> <li>• Inspect the pressure plate-to-flywheel bolts.</li> <li>• <b>Are any of the pressure plate-to-flywheel bolts loose?</b></li> </ul>	<p><b>Yes</b> TIGHTEN or INSTALL new bolts. REFER to Section 308-01. TEST the system for normal operation.</p> <p><b>No</b> GO to <b>E3</b>.</p>

(Continued)

**DIAGNOSIS AND TESTING (Continued)****PINPOINT TEST E: CLUTCH PEDAL PULSATION (Continued)**

Test Step		Result / Action to Take
<b>E3</b>	<b>INSPECT THE CLUTCH PRESSURE PLATE</b>	<b>Yes</b> INSTALL a new clutch pressure plate. REFER to Section 308-01. TEST the system for normal operation.  <b>No</b> GO to <b>E4</b> .
	<ul style="list-style-type: none"> <li>Remove the clutch pressure plate. Refer to Section 308-01.</li> <li>Inspect the clutch pressure plate for damage. Refer to Clutch Pressure Plate Check in this section.</li> <li><b>Are there any signs of damage present on the clutch pressure plate?</b></li> </ul>	
<b>E4</b>	<b>INSPECT THE CLUTCH DISC</b>	
	<ul style="list-style-type: none"> <li>Carry out the clutch disc inspection procedure. Refer to Clutch Disc Check in this section.</li> <li><b>Is the clutch disc OK?</b></li> </ul>	<b>Yes</b> GO to <b>E5</b> .  <b>No</b> INSTALL a new clutch disc. REFER to Section 308-01. TEST the system for normal operation.
<b>E5</b>	<b>INSPECT THE FLYWHEEL</b>	<b>Yes</b> VERIFY customer concern. GO to <a href="#">Symptom Chart</a> if necessary.  <b>No</b> TIGHTEN or INSTALL a new flywheel as necessary. Refer to the appropriate section in Group 303 for the procedure. TEST the system for normal operation.
	<ul style="list-style-type: none"> <li>Inspect the flywheel for damage and runout. Refer to Flywheel Runout Check in this section.</li> <li><b>Is flywheel OK?</b></li> </ul>	

**Pinpoint Test F: Clutch-Related Vibrations****Normal Operation**

The clutch is designed to transfer the power from the engine to the transmission, which may be either stationary (starting) or rotating at a different speed (upshifting or downshifting). The clutch is functioning correctly when both the engine and transmission are rotating at the same speed with the clutch engaged. Clutch pedal movement is transmitted by fluid pressure, which actuates the clutch release hub and bearing. The clutch release hub and bearing pushes on the spring center towards the flywheel. The diaphragm spring pivots at the fulcrum, relieving the load on the clutch pressure plate. Steel spring straps riveted in the clutch pressure plate cover pull the clutch pressure plate from the clutch disc, disengaging the engine torque from the transmission

**This pinpoint test is intended to diagnose the following:**

- Engine components
- Accessory drive belts
- Release bearing
- Flywheel

**PINPOINT TEST F: CLUTCH-RELATED VIBRATIONS**

Test Step		Result / Action to Take
<b>F1</b>	<b>CHECK FOR ENGINE COMPONENT GROUNDING</b>	<b>Yes</b> REPAIR the components as necessary. TEST the system for normal operation.  <b>No</b> GO to <b>F2</b> .
	<ul style="list-style-type: none"> <li>With the vehicle in NEUTRAL, position it on a hoist. Refer to Section 100-02.</li> <li>Check the engine and transmission mounts for grounding.</li> <li>Check for exhaust manifolds or other engine component grounding on the body or frame.</li> <li><b>Is there evidence of grounding on the body or frame?</b></li> </ul>	

(Continued)

**DIAGNOSIS AND TESTING (Continued)****PINPOINT TEST F: CLUTCH-RELATED VIBRATIONS (Continued)**

Test Step		Result / Action to Take
<b>F2</b>	<b>CHECK FOR ACCESSORY DRIVE VIBRATIONS</b>	<b>Yes</b> REFER to Section 303-05 to diagnose the accessory drive belt components. <b>No</b> STOP the engine and INSTALL the drive belt. GO to <b>F3</b> .
	<ul style="list-style-type: none"> <li>Start the engine.</li> <li>Remove the accessory drive belt.</li> <li><b>Does the vibration stop when the accessory drive belt is removed from the engine?</b></li> </ul>	
<b>F3</b>	<b>CHECK FOR CLUTCH RELEASE BEARING NOISE</b>	<b>Yes</b> INSTALL a new clutch release bearing. REFER to Section 308-01. <b>No</b> GO to <b>F4</b> .
	<b>NOTE:</b> With the transmission in NEUTRAL, transmission rollover noise can be heard. Make sure to distinguish between rollover noise and clutch release bearing noise. <ul style="list-style-type: none"> <li>Start the engine.</li> <li>Depress and hold the clutch pedal.</li> <li><b>Is a whirring, grating or grinding noise present only when pedal is pushed?</b></li> </ul>	
<b>F4</b>	<b>INSPECT THE FLYWHEEL</b>	<b>Yes</b> VERIFY customer concern. GO to <a href="#">Symptom Chart</a> if necessary. <b>No</b> TIGHTEN or INSTALL a new flywheel. Refer to the appropriate section in Group 303 for the procedure. TEST the system for normal operation.
	<ul style="list-style-type: none"> <li>Ignition OFF.</li> <li>Remove the transmission. Refer to the appropriate section in Group 308 for the procedure.</li> <li>Carry out a flywheel check. Refer to Flywheel Runout Check in this section.</li> <li><b>Is the flywheel OK?</b></li> </ul>	

**Pinpoint Test G: Excessive Noise****Normal Operation**

The clutch is designed to transfer the power from the engine to the transmission, which may be either stationary (starting) or rotating at a different speed (upshifting or downshifting). The clutch is functioning correctly when both the engine and transmission are rotating at the same speed with the clutch engaged. Clutch pedal movement is transmitted by fluid pressure, which actuates the clutch release hub and bearing. The clutch release hub and bearing pushes on the spring center towards the flywheel. The diaphragm spring pivots at the fulcrum, relieving the load on the clutch pressure plate. Steel spring straps riveted in the clutch pressure plate cover pull the clutch pressure plate from the clutch disc, disengaging the engine torque from the transmission.

**This pinpoint test is intended to diagnose the following:**

- Transmission
- Clutch slave cylinder
- Pilot bearing

**PINPOINT TEST G: EXCESSIVE NOISE**

Test Step		Result / Action to Take
<b>G1</b>	<b>TRANSMISSION NEUTRAL GEAR ROLLOVER TEST</b>	<b>Yes</b> INSPECT the clutch components for damage. REFER to General Procedures in this section. <b>No</b> GO to <b>G2</b> .
	<ul style="list-style-type: none"> <li>Start the engine and let it idle with the transmission in NEUTRAL and the clutch engaged (pedal up). If noise is excessive, depress the clutch pedal to stop the transmission input shaft from rotating.</li> <li><b>Does the noise stop when the clutch pedal is depressed?</b></li> </ul>	

(Continued)

**DIAGNOSIS AND TESTING (Continued)****PINPOINT TEST G: EXCESSIVE NOISE (Continued)**

Test Step		Result / Action to Take
<b>G2</b>	<b>CHECK THE CLUTCH SYSTEM</b>	<b>Yes</b> GO to <b>G3</b> . <b>No</b> The clutch system is OK. VERIFY customer concern.
	<ul style="list-style-type: none"> <li>• Engine OFF.</li> <li>• Using slow, medium, then fast strokes, depress and release the clutch pedal.</li> <li>• <b>Is there a squeak?</b></li> </ul>	
<b>G3</b>	<b>CHECK THE STARTER INTERLOCK SWITCH</b>	<b>Yes</b> REINSTALL the starter interlock switch. GO to <b>G4</b> . <b>No</b> INSTALL a new starter interlock switch. REFER to Section 308-02.
	<ul style="list-style-type: none"> <li>• Remove the starter interlock switch. Using slow, medium, then fast strokes, depress and release the clutch pedal.</li> <li>• <b>Is there a squeak?</b></li> </ul>	
<b>G4</b>	<b>CHECK THE CLUTCH SLAVE CYLINDER</b>	<b>Yes</b> INSTALL a new clutch slave cylinder. REFER to Section 308-01. <b>No</b> GO to <b>G5</b> .
	<ul style="list-style-type: none"> <li>• Remove the transmission. Refer to the appropriate section in Group 308 for the procedure.</li> <li>• Inspect the clutch slave cylinder for wear or loss of lubrication. Refer to Section 308-01.</li> <li>• <b>Are there any signs of wear or loss of lubrication?</b></li> </ul>	
<b>G5</b>	<b>CHECK THE PILOT BEARING</b>	<b>Yes</b> GO to <b>G6</b> . <b>No</b> INSTALL a new pilot bearing. REFER to Section 308-01.
	<ul style="list-style-type: none"> <li>• Inspect the pilot bearing for wear or damage.</li> <li>• <b>Is the pilot bearing OK?</b></li> </ul>	
<b>G6</b>	<b>CHECK THE TORSION SPRINGS</b>	<b>Yes</b> INSTALL a new clutch disc. REFER to Section 308-01. TEST the system for normal operation. <b>No</b> INSPECT the crankshaft end play.
	<ul style="list-style-type: none"> <li>• Inspect the torsion springs for fatigue or breakage.</li> <li>• <b>Are there any signs of fatigue or breakage?</b></li> </ul>	