

NOTE: READ THIS NOTICE BEFORE STARTING INSTALLATION
NOTA: LEA ESTE AVISO ANTES DE COMENZAR LA INSTALACIÓN
REMARQUE : LIRE CET AVIS AVANT DE COMMENCER L'INSTALLATION

NOTE : TO INSURE PROPER INSTALLATION, USE THE FOLLOWING GUIDELINES:
APPLY FLOCK TAPE TO SHARP OR JAGGED AREAS DURING INSTALLATION OF WIRE HARNESS
APPLY FLOCK TAPE TO WIRE HARNESS IN AREAS WHERE SQUEAK AND RATTLE CONDITIONS MAY OCCUR, I.E CONNECTORS
SECURE WIRE HARNESS AT LEAST 6MM FROM EXISTING SENSORS OR MODULES
SECURE WIRE HARNESS AT LEAST 19MM FROM MOVING PARTS, I.E. VACUUM MOTORS, ETC.

NOTA : PARA ASEGURAR LA INSTALACIÓN CORRECTA DEL EQUIPO, SIGA ESTAS INSTRUCCIONES:
APLIQUE CINTA DE FIELTRO EN LAS ÁREAS FILOSAS O DENTADAS DURANTE LA INSTALACIÓN DEL MAZO DE CABLES
APLIQUE CINTA AFIELTRADA (FLOC) AL MAZO DE CABLES EN EL ÁREA DONDE PODRÍAN PRODUCIRSE CHIRRIDOS O TRAQUETEOS, ES DECIR CONECTADORES
FIJE EL MAZO DE CABLES A UNA DISTANCIA DE AL MENOS 6 MM RESPECTO DE LOS SENSORES O MÓDULOS INSTALADOS
ASEGURE EL ARNÉS POR LO MENOS 19M M DEL ALAMBRE DE LAS PIEZAS MÓVILES, ES DECIR MOTORES DE VACÍO, ETC.

REMARQUE: POUR ASSURER UNE INSTALLATION CORRECTE, UTILISER LES DIRECTIVES SUIVANTES :
APPLIQUER DU RUBAN FLOQUÉ SUR LES PIÈCES TRANCHANTES OU ACÉRÉES PENDANT L'INSTALLATION DU FAISCEAU DE FILS.
APPLIQUER DU RUBAN FLOQUÉ SUR LES PARTIES DU FAISCEAU DE FIL RISQUANT DE PRODUIRE DES GRINCEMENTS OU DES VIBRATIONS, C.-I-D.. DES CONNECTEURS.
ASSUJETTIR LE FAISCEAU DE FILS À AU MOINS 6 MM DES MODULES ET CAPTEURS PRÉSENTS.
FIXEZ LE HARNAIS DE FIL AU MOINS 19MM DES PIÈCES MOBILES, C.-I-D.. MOTEURS À DÉPRESSION, ETC..

NOTE : IF AN UNRELIABLE METHOD OF WIRE SPLICING IS USED WHEN INSTALLING ELECTRICAL ADD-ON EQUIPMENT, IT MAY CAUSE ELECTRICAL SYSTEMS TO MALFUNCTION BY CREATING VARIABLE RESISTANCE OR A SHORT CIRCUIT. VARIABLE RESISTANCE CAN RESULT FROM OXIDATION/CORROSION CAUSED BY AIR WITHIN THE JOINT AND A SHORT CIRCUIT CAN RESULT FROM MOISTURE ON THE JOINT.

HEAT SHRINK TUBING MUST CONTAIN HOT MELT WAX. THIS WILL CREATE A WATERPROOF AND AIR TIGHT JOINT.

SOLDER MUST BE ROSIN CORE MILDLY ACTIVATED (RMA). DO NOT USE ACID CORE SOLDER.

DO NOT USE CRIMP-CONNECTORS OF ANY KIND. THEY ARE NOT A ROBUST METHOD FOR SPLICING IN NEW WIRES.

NOTA : SI SE UTILIZA UN MÉTODO DE EMPALME DE CABLES POCO CONFIABLE AL INSTALAR UN EQUIPO ELÉCTRICO ADICIONAL, ES POSIBLE QUE LOS SISTEMAS ELÉCTRICOS FUNCIONEN INCORRECTAMENTE AL GENERAR UNA RESISTENCIA VARIABLE O UN CORTOCIRCUITO. LA RESISTENCIA VARIABLE PUEDE SER OCASIONADA POR LA OXIDACIÓN O CORROSIÓN CAUSADA POR AIRE DENTRO DE LA JUNTA. EL CORTOCIRCUITO PUEDE SER OCASIONADO POR HUMEDAD EN LA JUNTA.

EL TUBO TERMOENCOGIBLE DEBE CONTENER PARAFINA CALIENTE DERRETIDA. ESTO DARÁ COMO RESULTADO UNA JUNTA HERMÉTICA Y A PRUEBA DE AGUA.

LA SOLDADURA DEBE SER DE N°CLEO DE RESINA DE FLUJO MODERADO (RMA). NO UTILICE SOLDADURA DE N°CLEO ÁCIDO.

NO UTILICE CONECTORES DE ENGARCE DE NINGÚN TIPO. NO SON UN MÉTODO ADECUADO PARA EMPALMAR A CABLES NUEVOS.

REMARQUE: SI UNE MÉTHODE INCERTAINE D'ÉPISSAGE DE FIL EST UTILISÉE PENDANT L'INSTALLATION D'ÉQUIPEMENT ÉLECTRIQUE COMPLÉMENTAIRE, ELLE PEUT ENTRAINER DES VARIATIONS DE RÉSISTANCE ET DES COURT-CIRCUITS POUVANT RÉSULTER EN DES PANNES DE SYSTÈME. LES VARIATIONS DE RÉSISTANCE PEUVENT ÊTRE CAUSÉES PAR L'OXYDATION ET LA CORROSION RÉSULTANT DE LA PRÉSENCE D'AIR DANS LES JOINTS, ET LES COURTS-CIRCUITS, DE LA PRÉSENCE D'HUMIDITÉ.

LE TUBE THERMORÉTRÉCISSABLE DOIT CONTENIR DE L'ADHÉSIF THERMOFUSIBLE. CECI PERMETTRA DE CRÉER UN JOINT ÉTANCHE À L'EAU ET HERMÉTIQUE.

LA SOUDURE DOIT ÊTRE NOYÉE DANS LA RÉSINE LÉGÈREMENT ACTIVÉE (RMA). N'UTILISEZ PAS DE SOUDURE À L'ACIDE.

N'UTILISEZ PAS DE RACCORD À SERTIR. ILS NE CONSTITUENT PAS UN MOYEN SOLIDE D'ÉPISSAGE DES NOUVEAUX FILS.

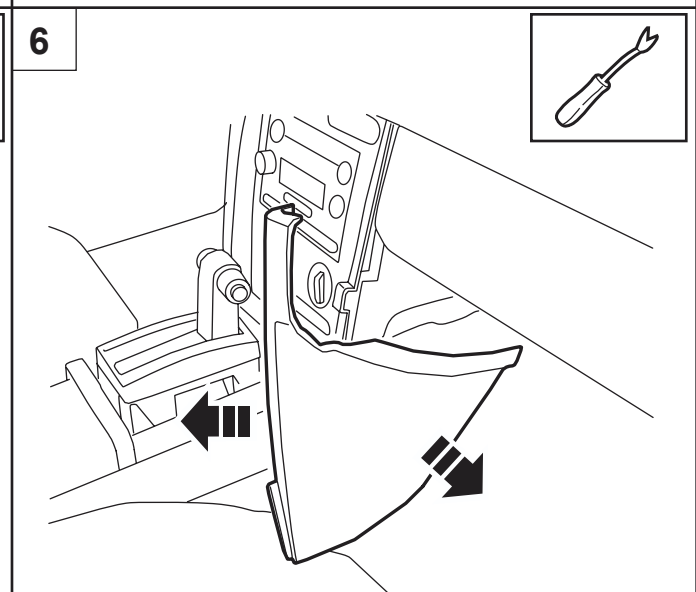
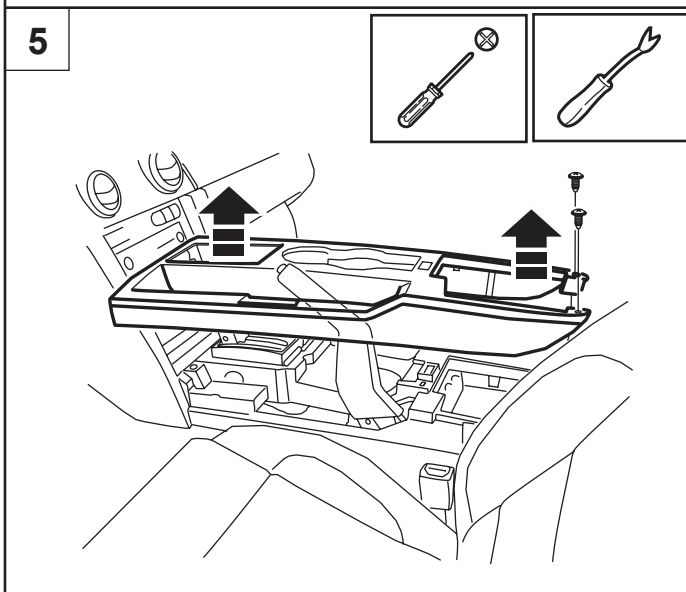
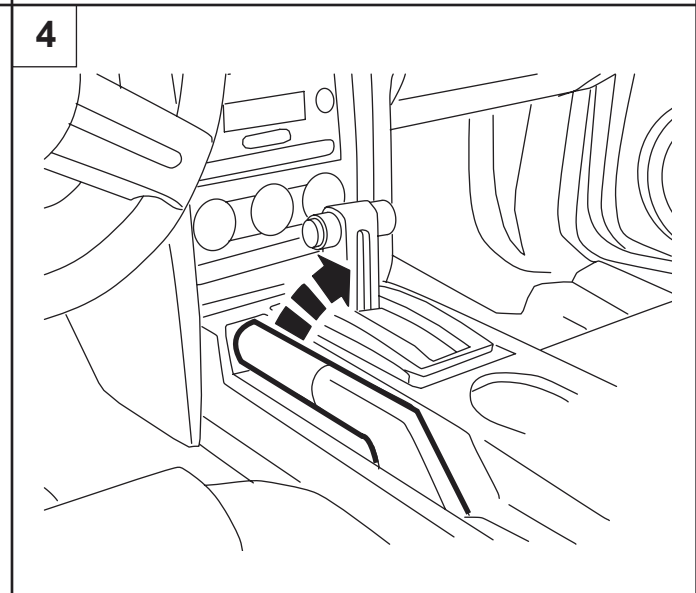
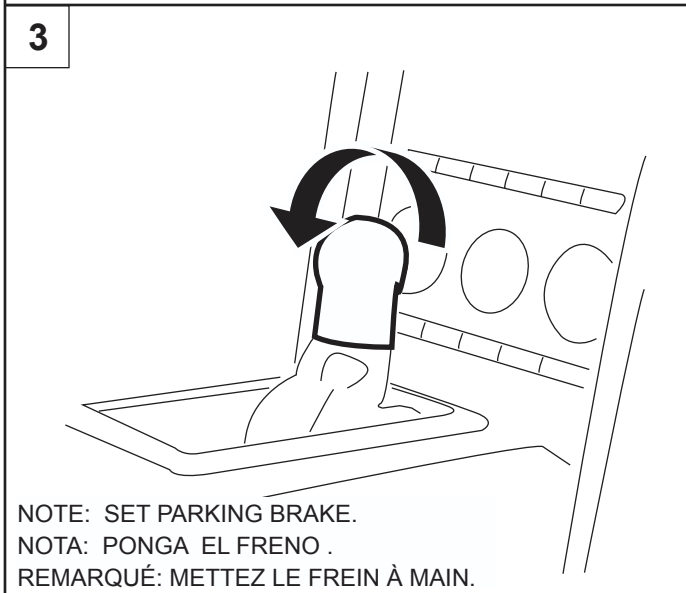
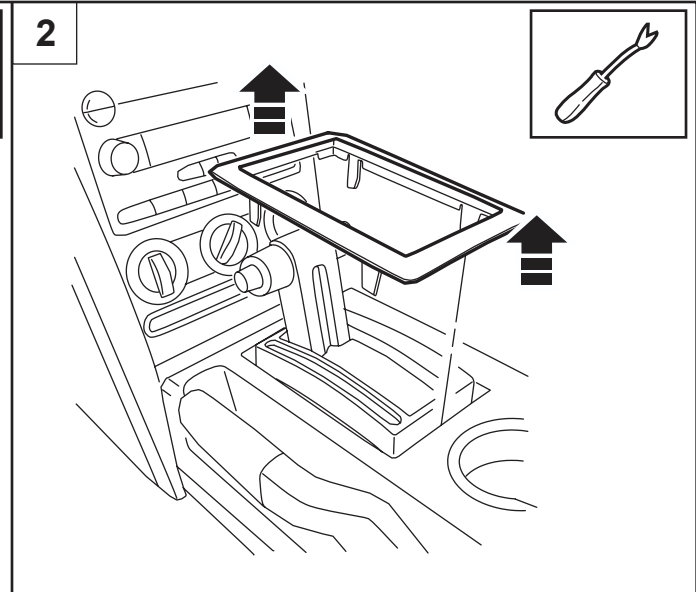
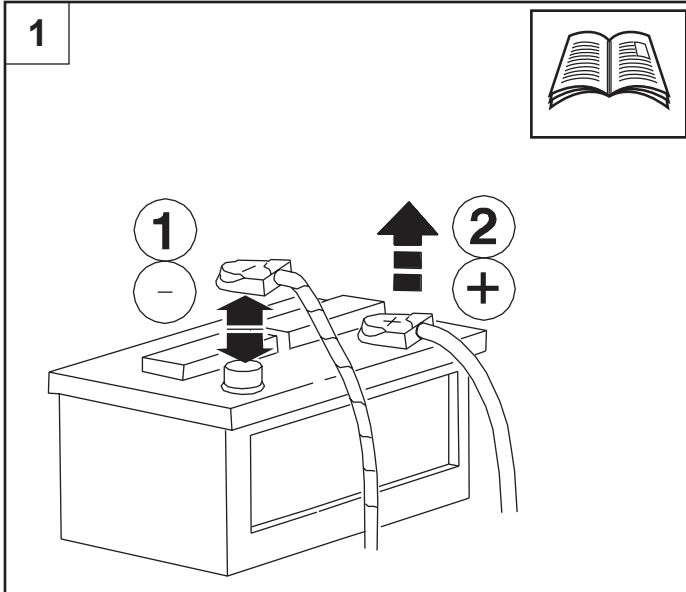

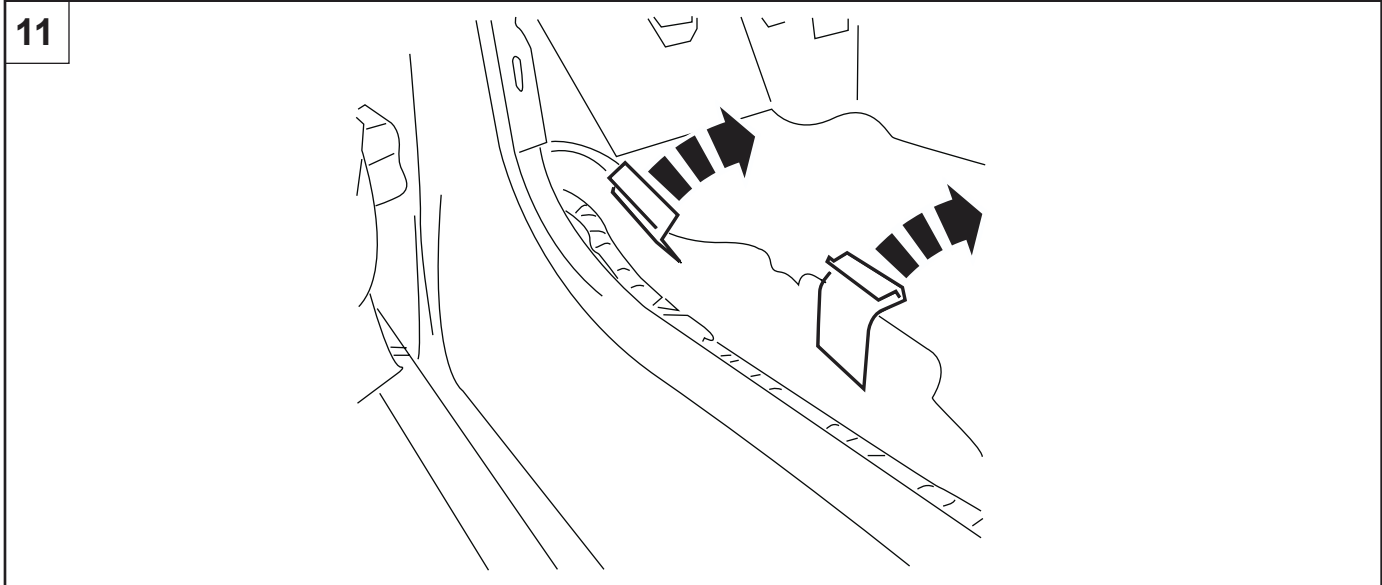
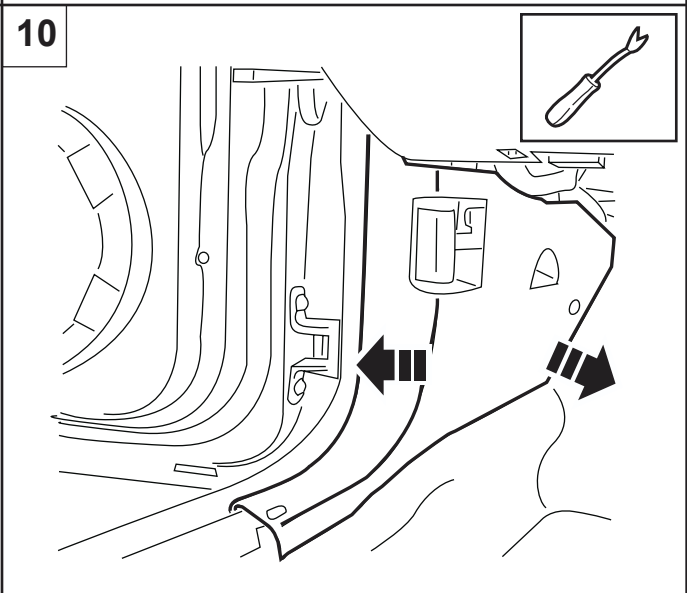
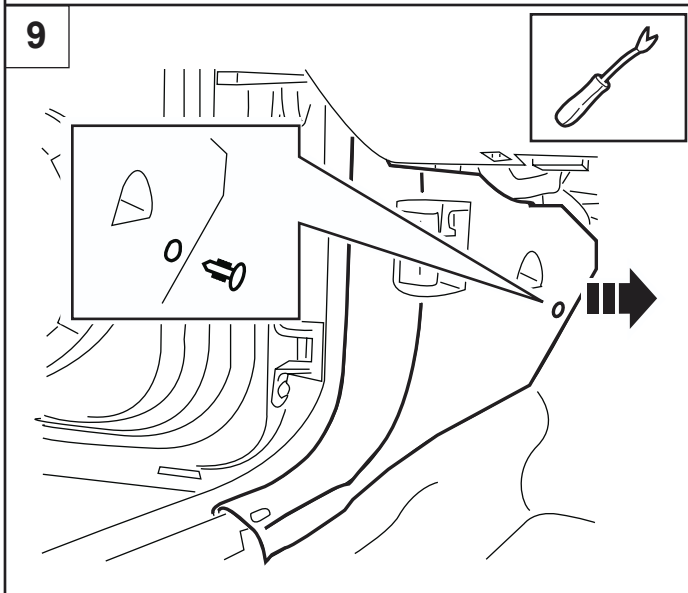
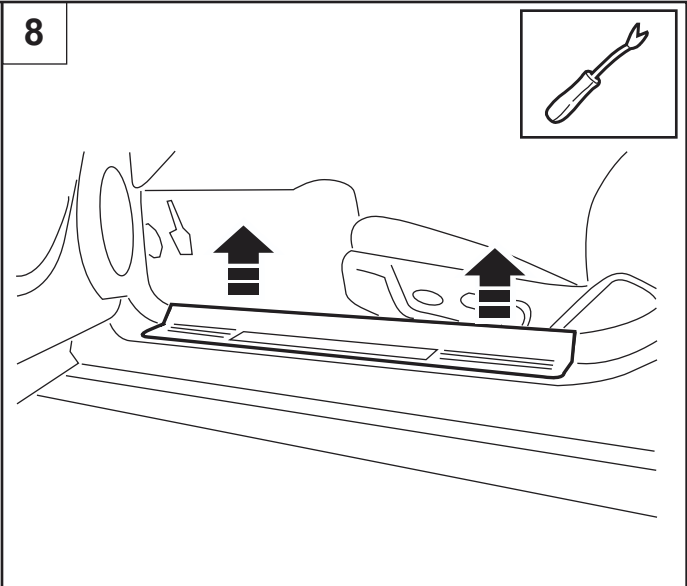
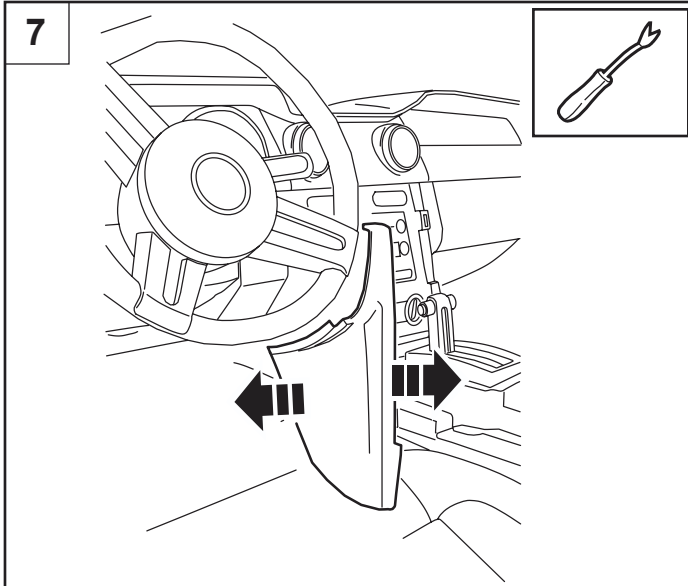

12

NOTE: POWER LEAD IS ROUTED UNDER CARPET STARTING AT CENTER CONSOLE. LIFT CARPET AT DOOR SILL TO REACH POWER LEAD.

NOTA: PONGA EL CABLE ELECTRICO DEBAJO DE LA ALFOMBRA COMENZANDO EN EL CENTRO DE LA CONSOLA. LEVANTE LA ALFOMBRA EN LA ESQUINA PARA ALCANZAR EL CABLE ELECTRICO.

REMARQUÉ: LE CABLE ÉLECTRIQUE EST SOUS LE TAPIS QUI COMMENCE AUPRES DE LA CONSOLE. LEVEZ LA CÔTÉ DU TAPIS QUI EST PRÈS DE LA PORTE POUR PRENDRE LE CABLE.

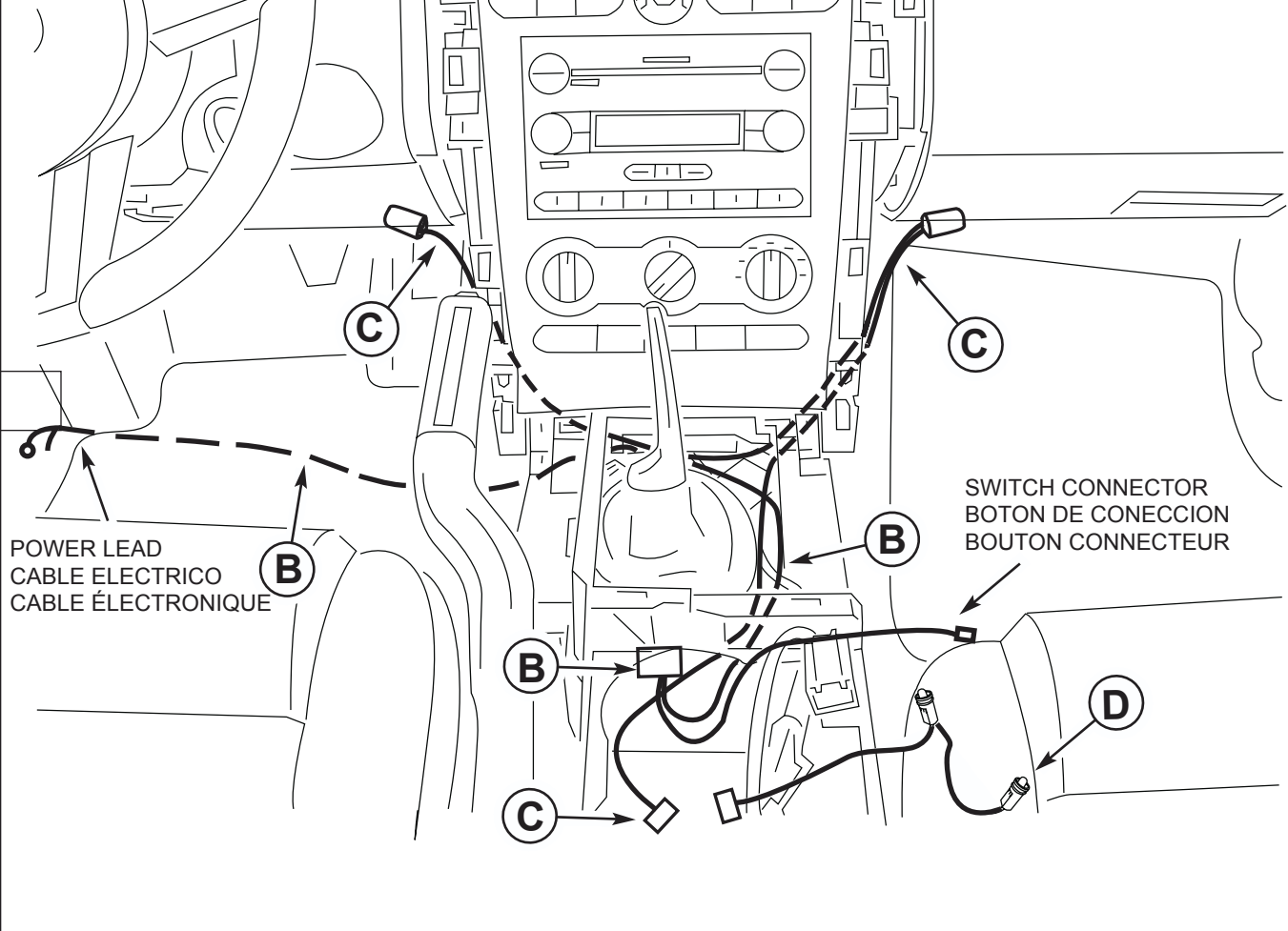

13

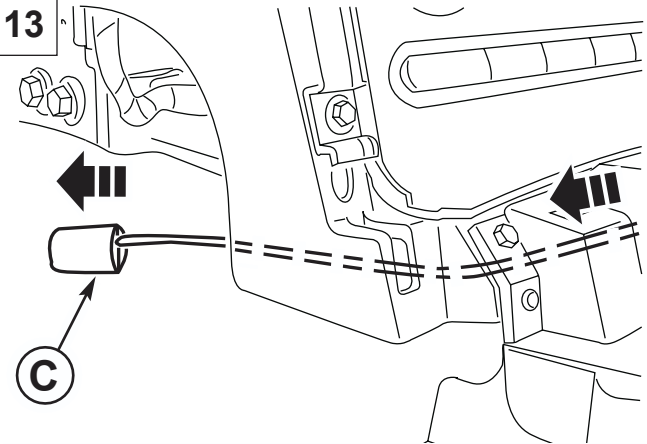

NOTE: ROUTE BEHIND AND OVER CARPET.
NOTA: PASE POR ATRAS Y ENCIMA DE LA ALFOMBRA.
REMARQUÉ: FAIRE PASSER EN ARIERRE ET DESSUS LE TAPIS.

14

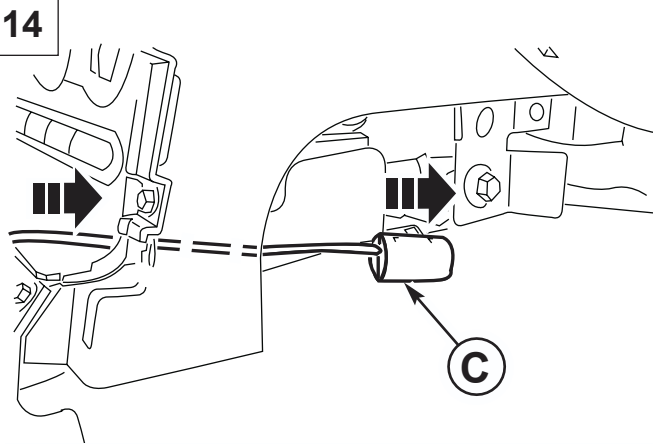

NOTE: ROUTE BEHIND AND OVER CARPET.
NOTA: PASE POR ATRAS Y ENCIMA DE LA ALFOMBRA.
REMARQUÉ: FAIRE PASSER EN ARIERRE ET DESSUS LE TAPIS.

15

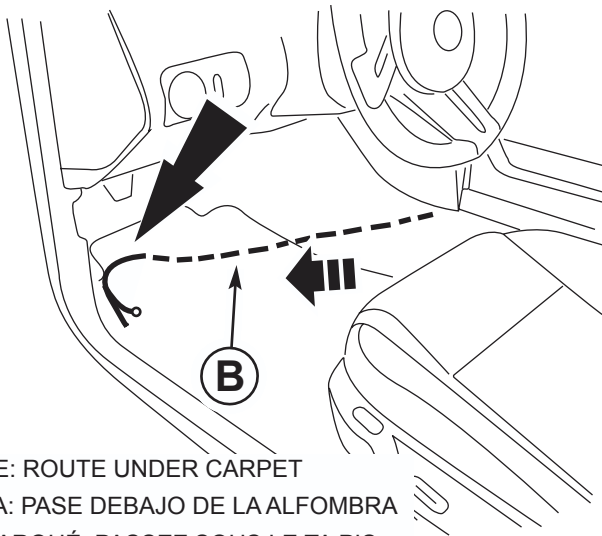

NOTE: ROUTE UNDER CARPET
 NOTA: PASE DEBAJO DE LA ALFOMBRA
 REMARQUÉ: PASSEZ SOUS LE TA PIS

16

NOTE: VERIFY LOCATION AND COLOR CODE OF POWER

NOTA: VERIFICA LOCALIZACION Y EL COLOR DE CODIGO DE LA CONECCION ELECTRICA.

REMARQUÉ: VÉRIFIÉ LA LOCATION ET LA COULER DE LA PUISSANCE.

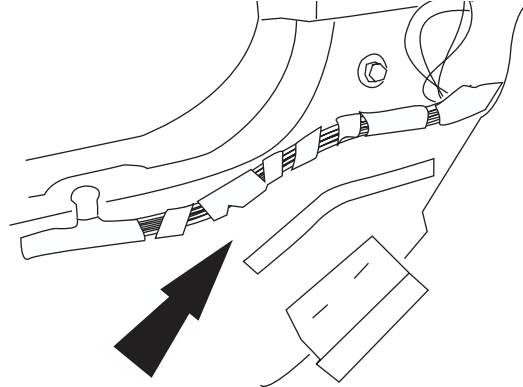

17

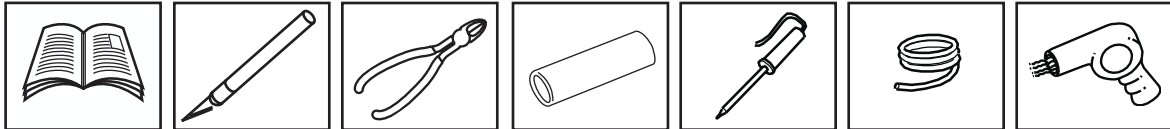

NOTE: TO LOCATE TAN/RED OR DARK BLUE/YELLOW WIRE, FOLLOW HARNESS TO GENERAL LOCATION SHOWN IN CELL 16. VERIFY WITH PIN 24 OR 38 CONNECTOR C2280D

NOTA: PARA UBICAR EL CABLE TAN/ROJO O AZUL MARINO/AMARILLO ENCUENTRE LA LOCALIZACION GENERAL EN LA CELULA NUMERO 16. VERIFIQUE CON LA AGUJA 24 O 38 CONECCION C2280D

REMARQUE : POUR LOCALISER LE FIL TAN/ROUGE OU BLEU-FONCÉ/JAUNE, SUIVEZ JUSQU' AU LOCATION GÉNÉRALE. VOYEZ CELLULE 16. VÉRIFIÉ AVEC LE CONNECTEUR C2208D

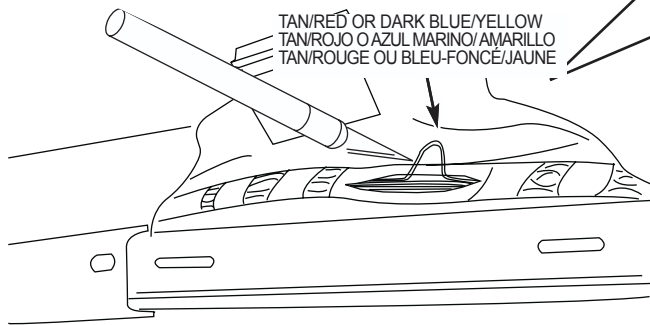
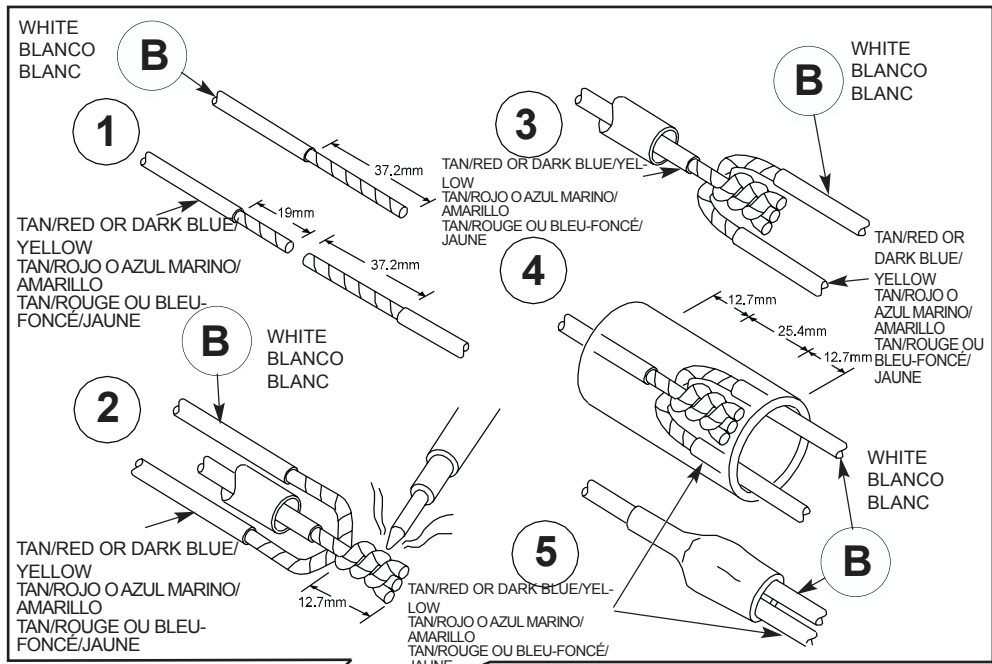

POWER SOURCE
 FUENTE DE ENERGÍA
 SOURCE D'ÉNERGIE

COMPONENT
 COMPONENTE
 COMPOSANT

CONNECTOR
 CONECCION
 CONNECTEUR

PIN
 AGUJA
 GOUPILLE

SJB SMART
 JUNCTION BOX

C2280D

24 OR 38

CIRCUIT
 CIRCUITO
 CIRCUIT

COLOR
 COLOR
 COULEUR

1784 0R 1729

TAN/RED OR DARK BLUE/YELLOW
 TAN/ROJO O AZUL MARINO/AMARILLO
 TAN/ROUGE OU BLEU-FONCÉ/JAUNE



18

NOTE: VERIFY ELECTRICAL CONNECTIONS.
NOTE: VERIFIQUE LAS CONECCIONES ELECTRICAS.
REMARQUÉ: VERIFIÉ LES CONNEXIONS ÉLECTRIQUES.

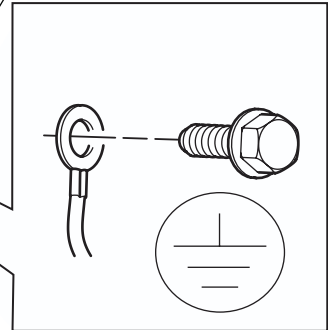
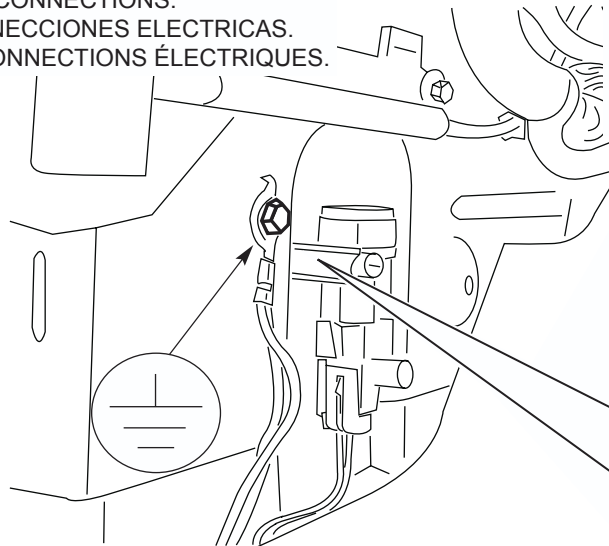
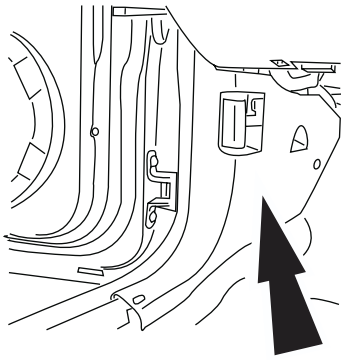
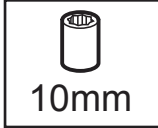

19

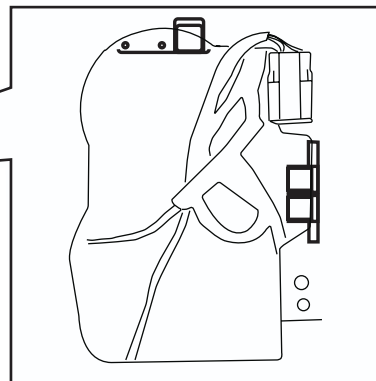
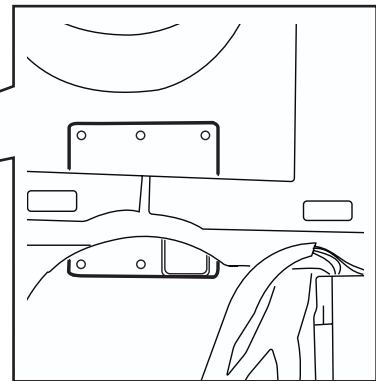
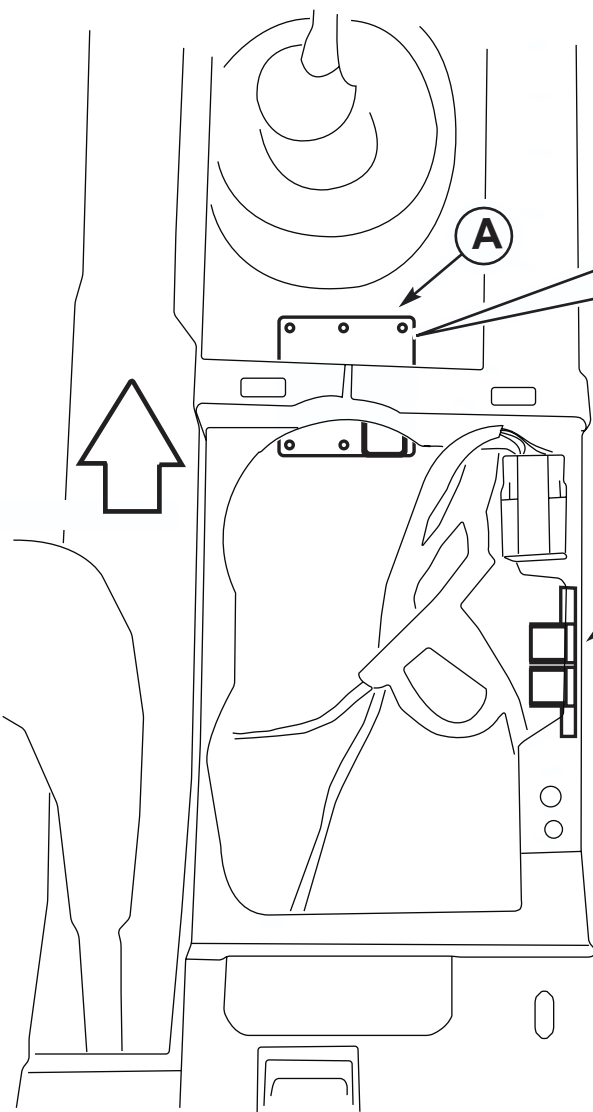

B

20

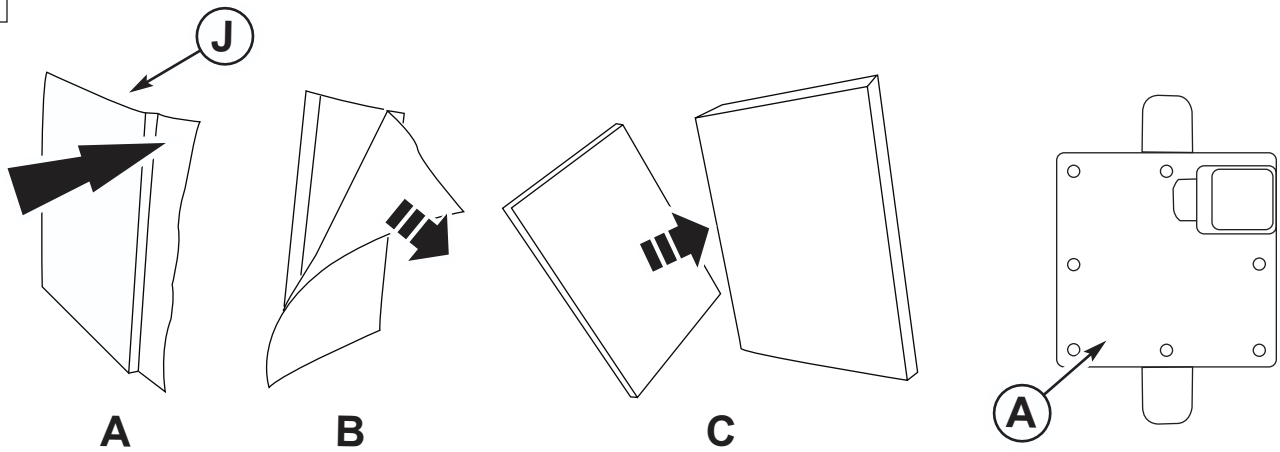

21

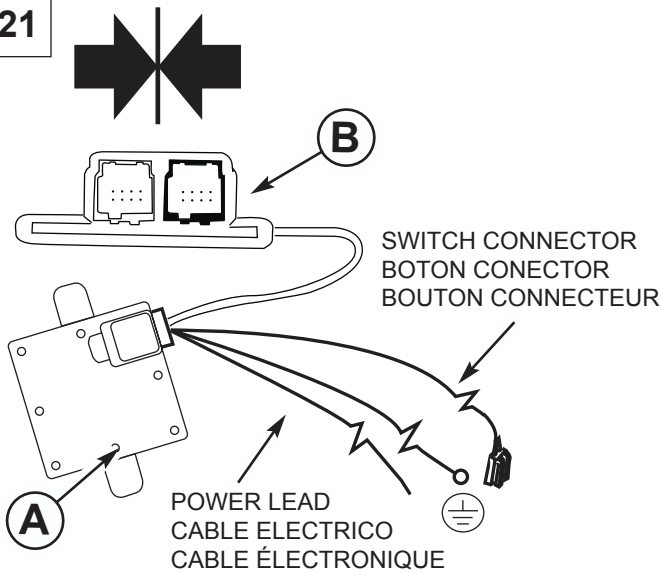

22

NOTE: CONECT GRAY CONNECTOR TO GRAY PLUG, BLACK CONNECTOR TO BLACK PLUG. CONNECTOR TO (A) CAN BE DISCONNECTED TO AID INSTALLATION.

NOTA: CONECTA EL CONECTOR GRIS A LA ENTRADA GRIS, EL CONECTOR NEGRO A LA ENTRADA NEGRA. EL CONECTOR PUEDE SER DESCONECTADO PARA AYUDAR LA INSTALACION.

REMARQUÉ : BRANCHEZ LE CONNECTEUR GRIS À LA PRISE GRISE, CONNECTEUR NOIR À LA PRISE NOIRE. LE CONNECTEUR À (A) PEUT ÊTRE DÉBRANCHÉ POUR FACILITER L'INSTALLATION.

23

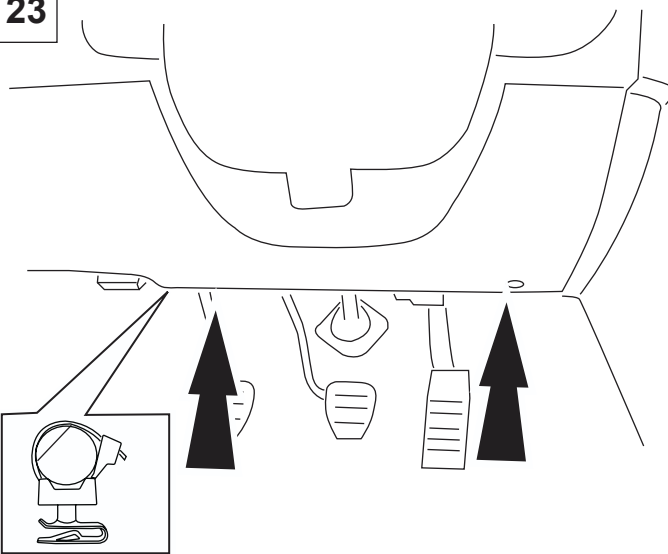

24



NOTE: CLIPS MOUNTED TO METAL LIP BEHIND KNEE BOLSTER.

NOTA: MONTE EL "U" CLIP EN LABIO DE METAL DETRAS DEL "BOLSTER" COLLARIN.

REMARQUÉ: METTEZ LES "U" CLIP EN ARRIÈRE DU TRAVERSIN

25

NOTE: LOOSELY ASSEMBLED BEFORE SLIPPING ONTO EDGE.

NOTA: LIGERAMENTE MONTE ANTE DE PONER EN LA ESQUINA.

REMARQUÉ: ASSEMBLÉ LÂCHEMENT AVANT DE PASSER SUR LE BEC.

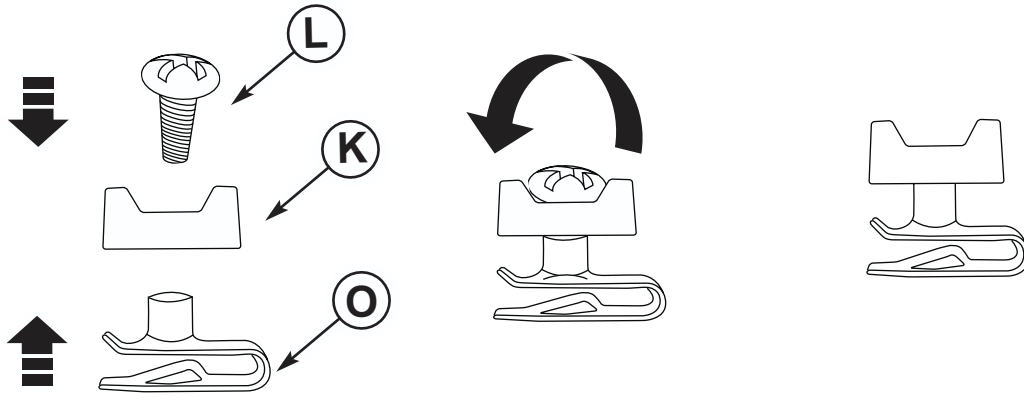
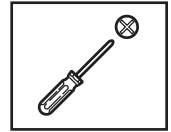

26

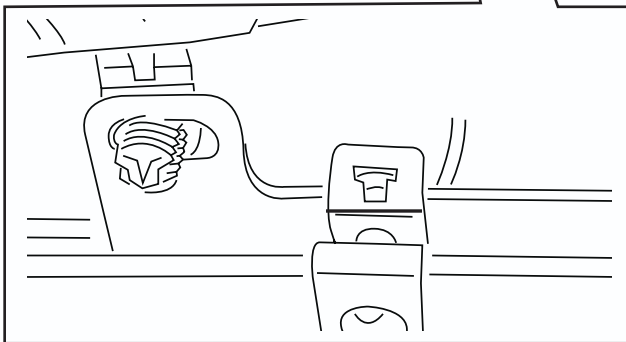
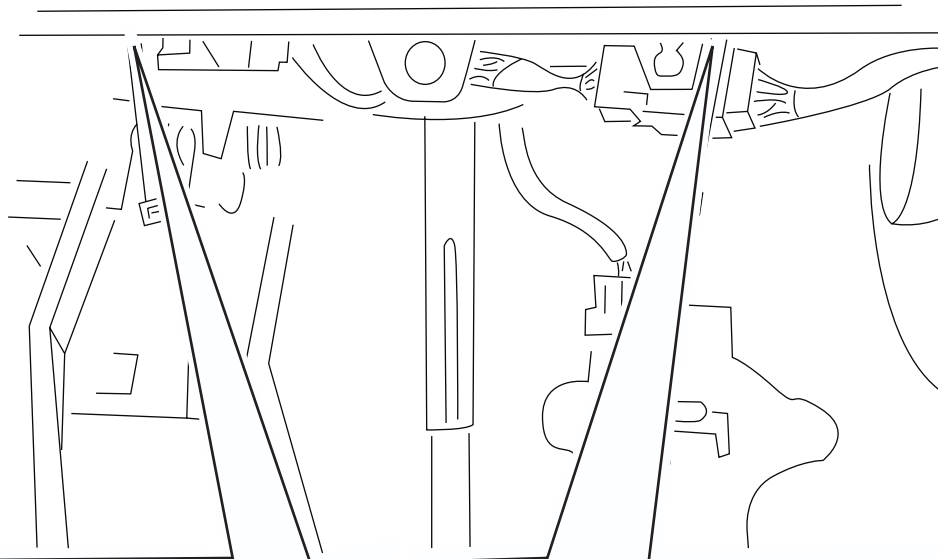

NOTE: CRADLE SHOULD BE AT TOP.
NOTA: LA CUNA DEBE ESTAR ARRIBA
REMARQUÉ: LE BNERCEAU DOIT ÊTRE.

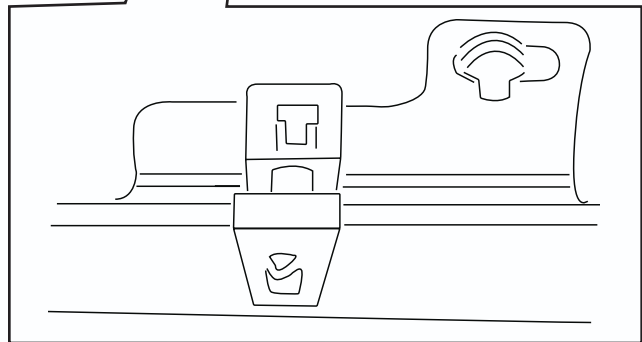

NOTE: TIGHTEN SCREW.
NOTA: APRIETE EL TORNILLO
REMARQUÉ: TENDRE LE VIS.

27

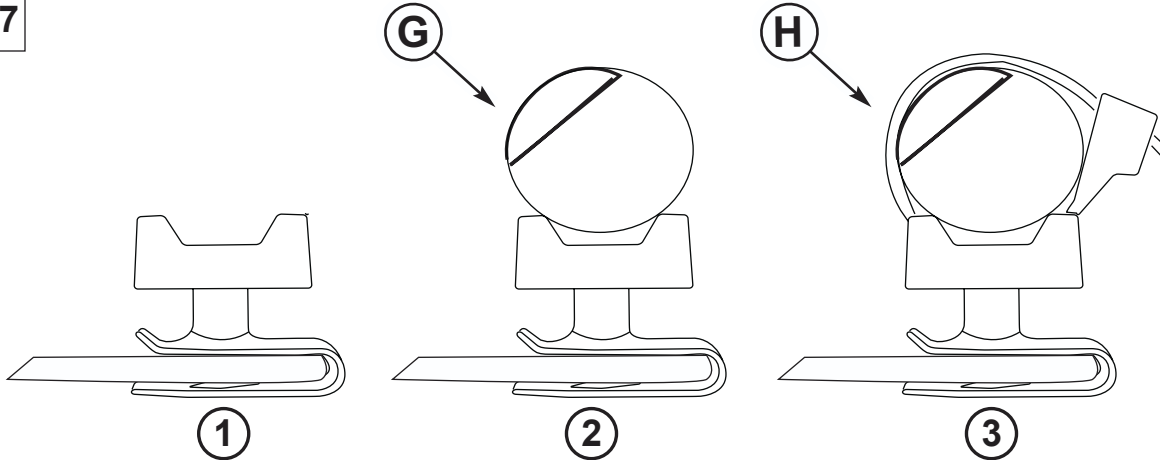

NOTE: PLACE ROD ON CRADLE AND CENTER.
 NOTA: PONGA TUBO EN LA CUNA Y EL MEDIO.
 REMARQUÉ: PLACEZ LA TIGE AU MILIEU DU BERCEAU.

NOTE: SECURE ROD WITH CABLE TIE AND TRIM.
 NOTA: ASEGURE EL TUBO CON EL CABLE Y CORTE.
 REMARQUÉ: ASSURÉ LA TIGE AVEC LE CABLE, ATTACHÉ L'HABILAGE.

28

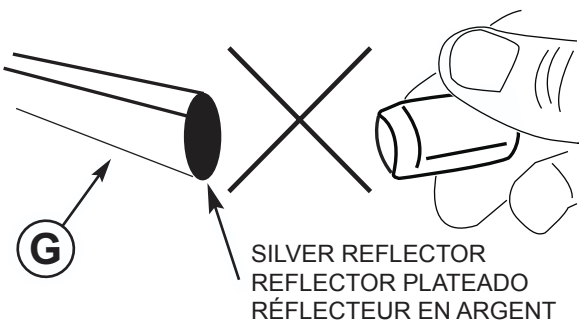

NOTE: DO NOT INSTALL REFLECTOR END INTO LIGHT MODULE.

NOTA: NO INSTALE EL EXTREMO DEL REFLECTOR EN EL MODULO DE LA LUZ.

REMARQUÉ: N'INSTALLEZ PAS LE RÉFLECTEUR DANS LE MODULE DE LUMIÈRE.

29

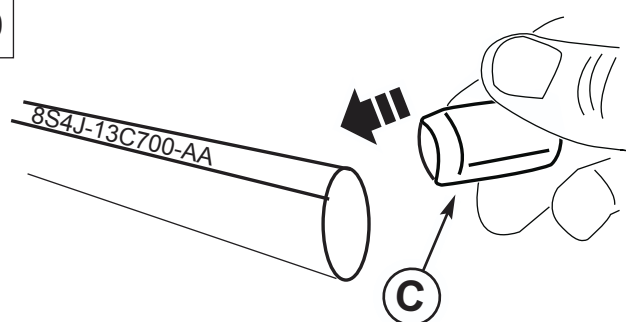

NOTE: INSTALL MODULE ON END WITH PART NUMBER

NOTA: INSTALE EL MODULO EN EL EXTREMO DE LA PARTE

REMARQUÉ: INSTALLEZ LE MODULE AVEC LE NUMERO DE PIÈCE.

30

NOTE: ORIENT ROD WITH WHITE STRIPE ORIENTED AS ILLUSTRATED IN FRAME 31. REFLECTOR END TOWARDS OUTSIDE OF VEHICLE.

NOTA: ORIENTE EL TUBO CON EL LINEA BLANCA ILUSTRADA EN LA CELULA 31. PONGA EL EXTREMO DEL REFLECTOR HACIA FUERA DEL VEHICULO.

REMARQUÉ: METTEZ LA TIGE AVEC LA RAYURE BLANCHE COMME DANS LE DESSIN DANS LA 31. AVEC LE BOUT DU RÉFLECTEUR VERS L'EXTÉRIEUR DU VOITURE.

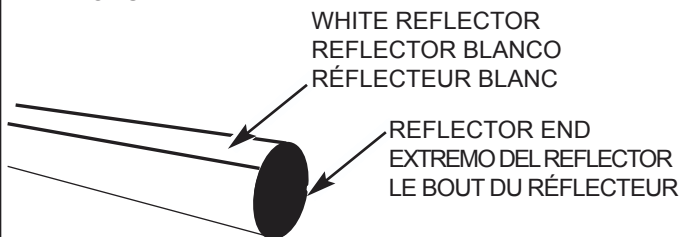

31

NOTE: WHEN INSTALLATION IS COMPLETE ORIENT ROD SO LIGHT SHINES IN FOOT AREA.

NOTA: CUANDO LA INSTALACION ESTE COMPLETA ORIENTE LA LUZ PARA QUE ALUMBRE EN EL AREA DEL PIE.

REMARQUÉ: QUAND L'INSTALLATION EST COMPLÈTE METTEZ LA TIGE DANS UNE FAÇON QUI VA LAISSER LA LUMIÈRE ÉCLAT DANS L'ESPACE POUR LES PIEDS.

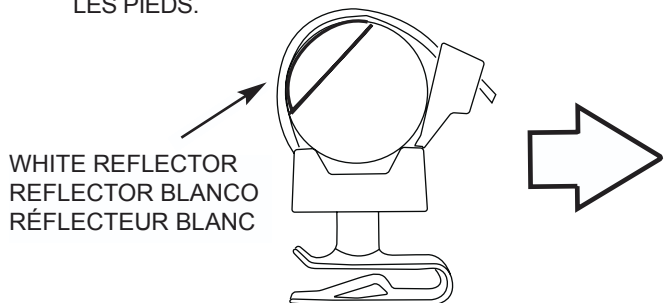

32

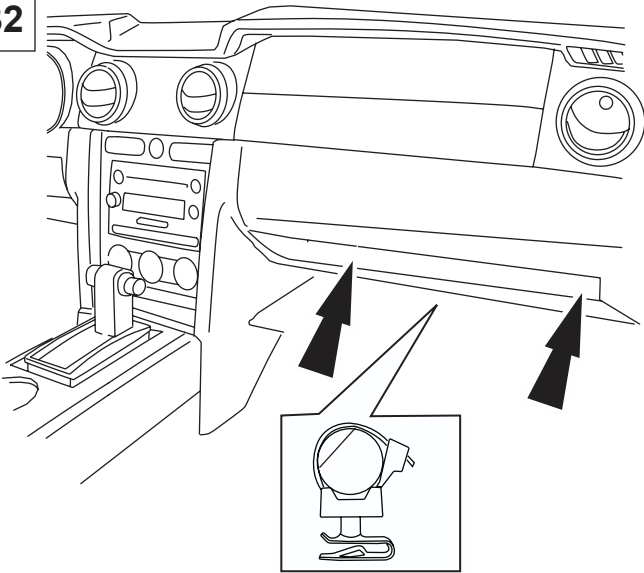

33

NOTE: LOOSEN, DO NOT REMOVE.
 NOTA: SULTE, NO REMUEVA.
 REMARQUÉ: LACHÉ NE REMPLACEZ PAS



34

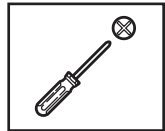
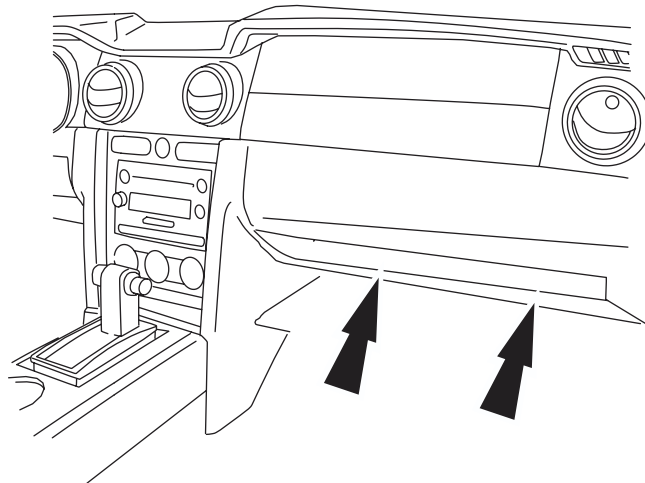

35

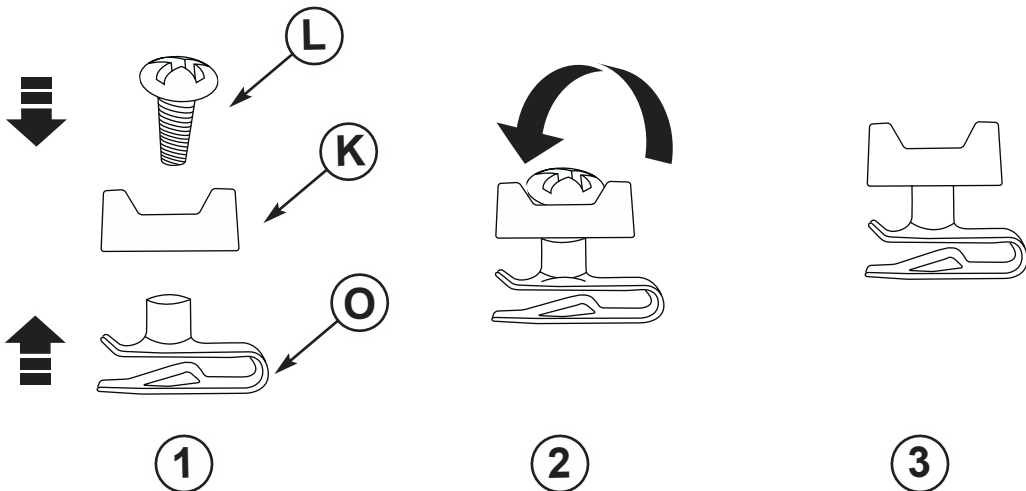

36

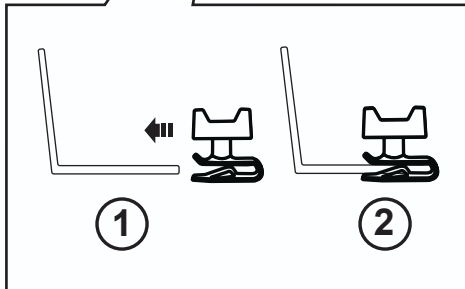
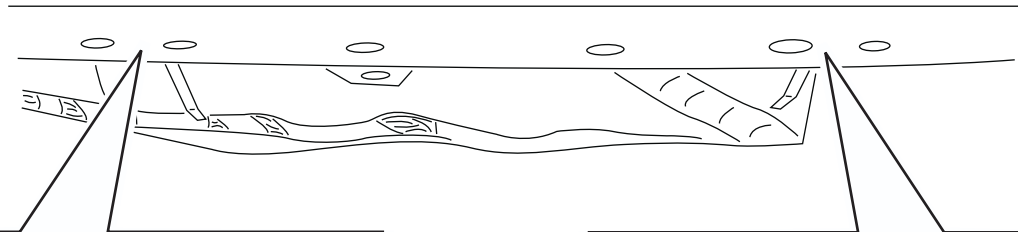
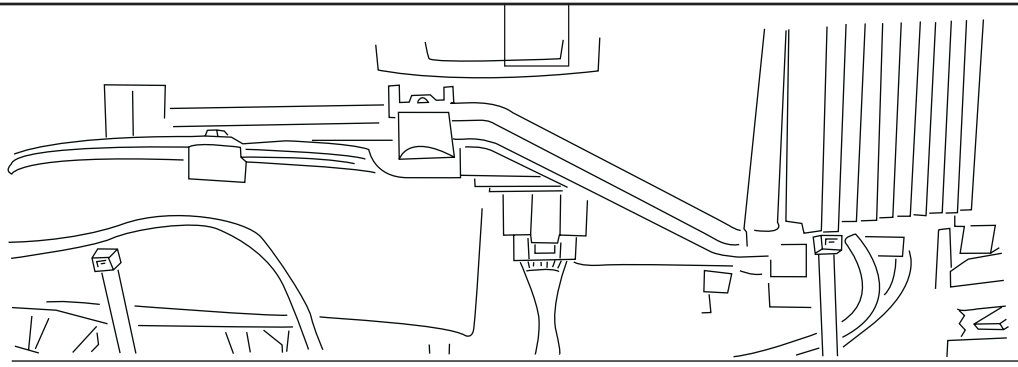

NOTE: CRADLE SHOULD BE AT TOP.
 NOTA: LA CUNA DEBE ESTAR ARRIBA
 REMARQUÉ: LE BNERCEAU DOIT ÊTRE.

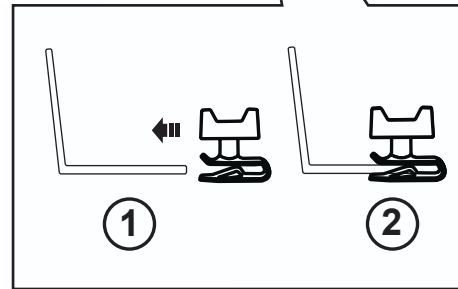

NOTE: TIGHTEN SCREW.
 NOTA: APRIETE EL TORNILLO
 REMARQUÉ: TENDRE LE VIS.

37

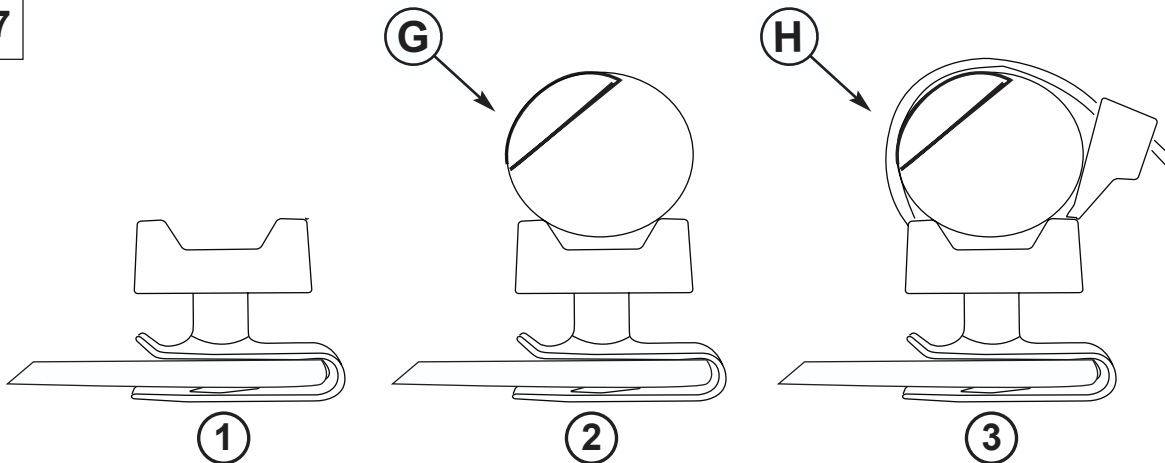

NOTE: PLACE ROD ON CRADLE AND CENTER.
 NOTA: PONGA TUBO EN LA CUNA Y EL MEDIO.
 REMARQUÉ: PLACEZ LA TIGE AU MILIEU DU BERCEAU.

NOTE: SECURE ROD WITH CABLE TIE AND TRIM.
 NOTA: ASEGURE EL TUBO CON EL CABLE Y CORTE.
 REMARQUÉ: ASSURÉ LA TIGE AVEC LE CABLE, ATTACHÉ L'HABILLAGE.

38

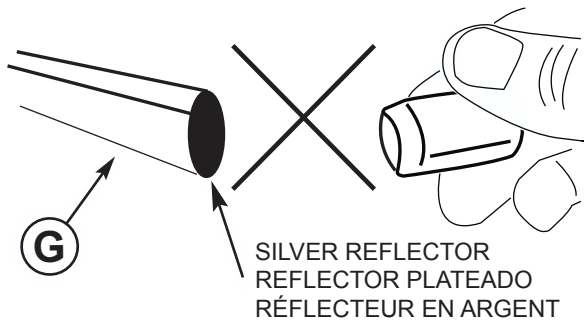

NOTE: DO NOT INSTALL REFLECTOR END INTO LIGHT MODULE.

NOTA: NO INSTALE EL EXTREMO DEL REFLECTOR EN EL MODULO DE LA LUZ.

REMARQUÉ: N'INSTALLEZ PAS LE RÉFLECTEUR DANS LE MODULE DE LUMIÈRE.

39

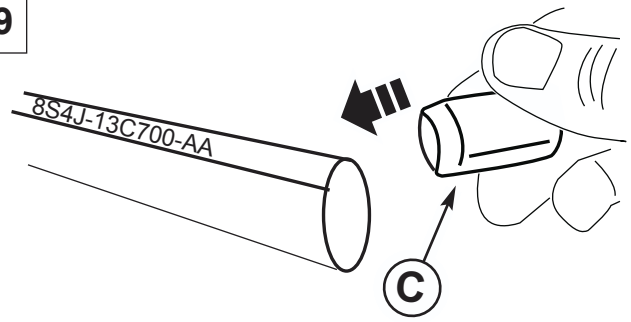

NOTE: INSTALL MODULE ON END WITH PART NUMBER

NOTA: INSTALE EL MODULO EN EL EXTREMO DE LA PARTE

REMARQUÉ: INSTALLEZ LE MODULE AVEC LE NUMERO DE PIÈCE.

40

NOTE: ORIENT ROD WITH WHITE STRIPE ORIENTED AS ILLUSTRATED IN FRAME 41 REFLECTOR END TOWARDS OUTSIDE OF VEHICLE.

NOTA: ORIENTE EL TUBO CON EL LINEA BLANCA ILUSTRADA EN LA CELULA 41. PONGA EL EXTREMO DEL REFLECTOR HACIA FUERA DEL VEHICULO.

REMARQUÉ: METTEZ LA TIGE AVEC LA RAYURE BLANCHE COMME DANS LE DESSIN DANS LA 41. AVEC LE BOUT DU RÉFLECTEUR VERS L'EXTÉRIEUR DU VOITURE.

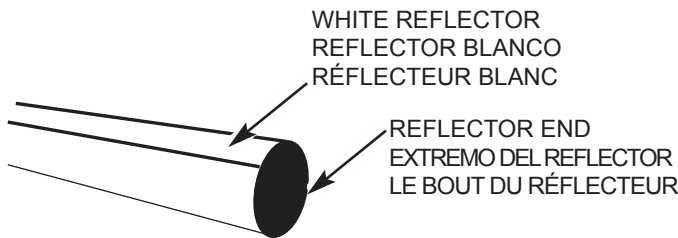

41

NOTE: WHEN INSTALLATION IS COMPLETE ORIENT ROD SO LIGHT SHINES IN FOOT AREA.

NOTA: CUANDO LA INSTALACION ESTE COMPLETA ORIENTE LA LUZ PARA QUE ALUMBRE EN EL AREA DEL PIE.

REMARQUÉ: QUAND L'INSTALLATION EST COMPLÈTE METTEZ LA TIGE DANS UNE FAÇON QUI VA LAISSER LA LUMIÈRE ÉCLAT DANS L'ESPACE POUR LES PIEDS.

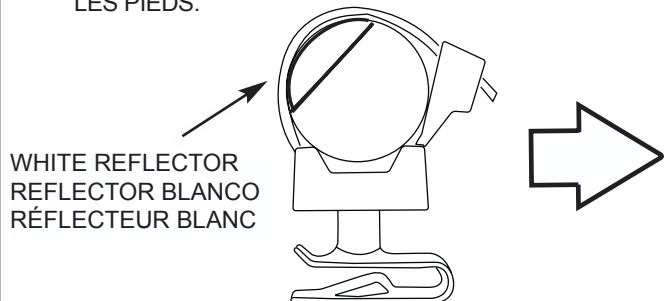

42

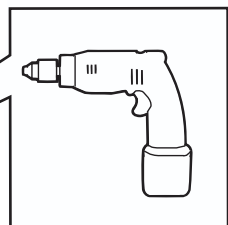
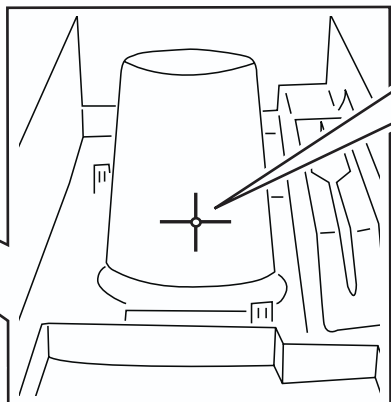
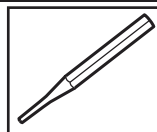
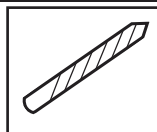
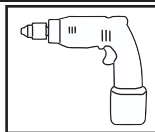
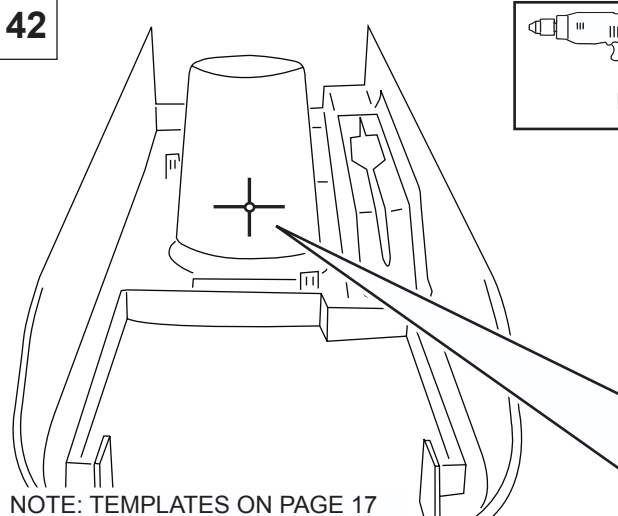

NOTE: TEMPLATES ON PAGE 17
NOTA: MOLDE EN LA PAGINA 17
REMARQUÉ: LES MODÈLE SONT SUR LA PAGE 17

43

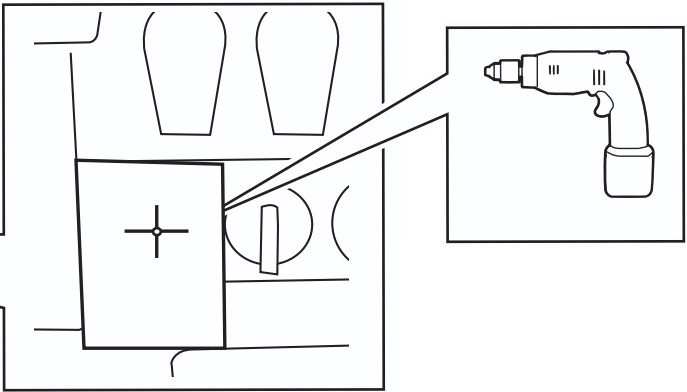
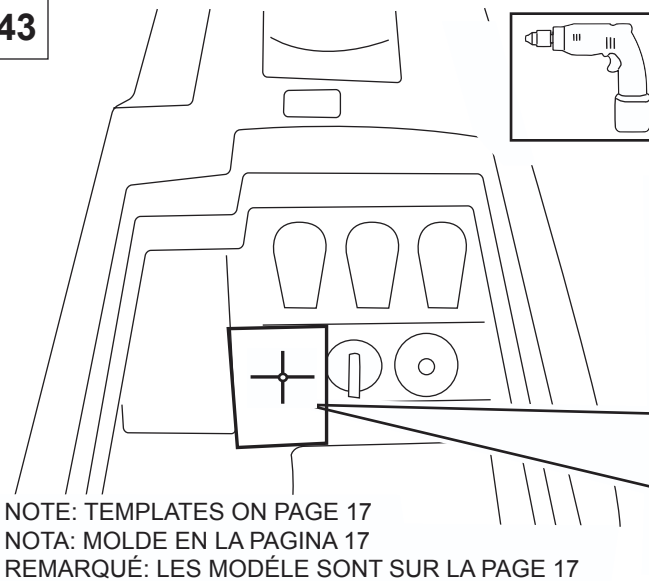
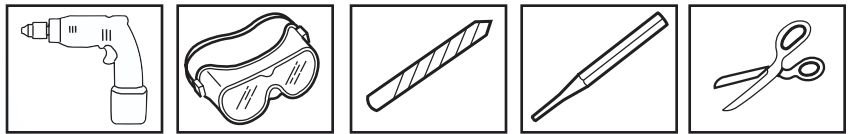

NOTE: TEMPLATES ON PAGE 17
 NOTA: MOLDE EN LA PAGINA 17
 REMARQUÉ: LES MODÉLE SONT SUR LA PAGE 17

44

NOTE: TEMPLATES ON PAGE 17
 NOTA: MOLDE EN LA PAGINA 17
 REMARQUÉ: LES MODÉLE SONT SUR LA PAGE 17

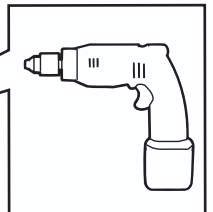
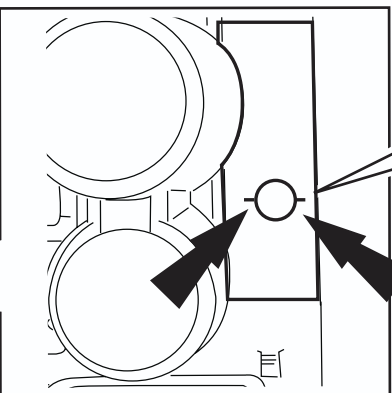
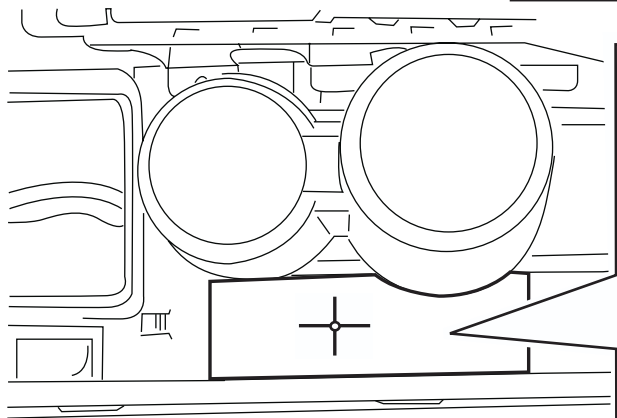
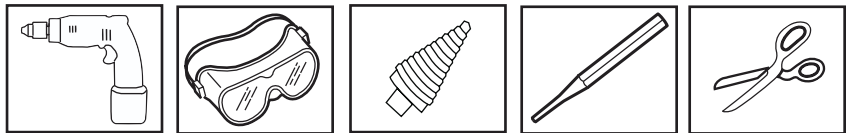

NOTE: FILE NOTCH 2X2MM
 NOTE: LIGE CORTE 2X2MM
 REMARQUÉ: CLASSEZ EN-TAILLE 2X2MM

45

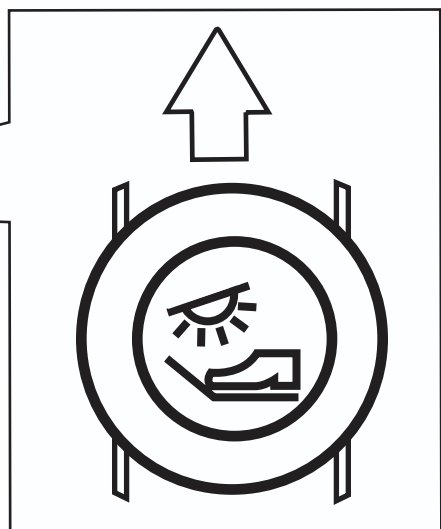
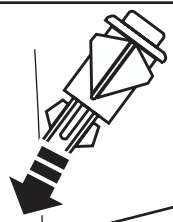
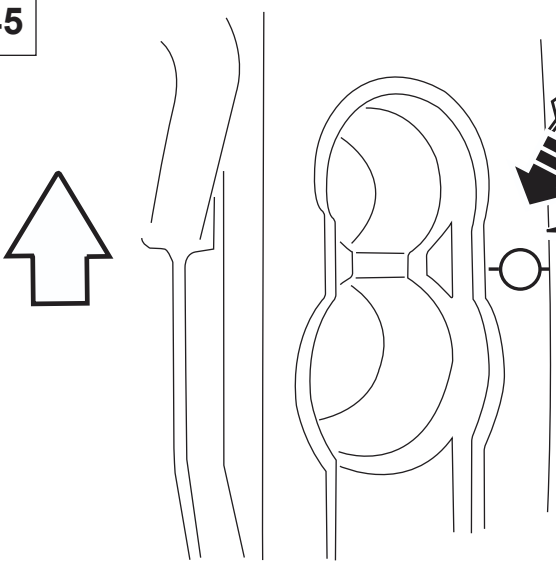

46

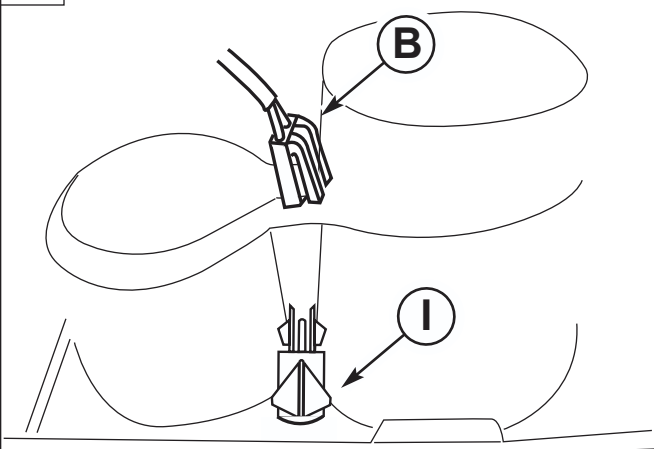

47

LED INSTALLATION
 INSTALACION LED
 LED INSTALLATION

- A. REMOVE TAPE LINER FROM LENS
 REMUEVALA CINTA DEL LENTE
 ENLEVEZ LE RUBAN QUI EST SUR LA LENTILLE
- B. INSERT LENS
 INSERTE EL LENTE
 INSEREZ LA LENTILE
- C. SECURE LED WHILE HOLDING LENS
 ASEGURE EL LED MIENTRAS AGUANTA EL LENTE
 SECUREZ "LED" EN TRANT LA LENTILLE

48

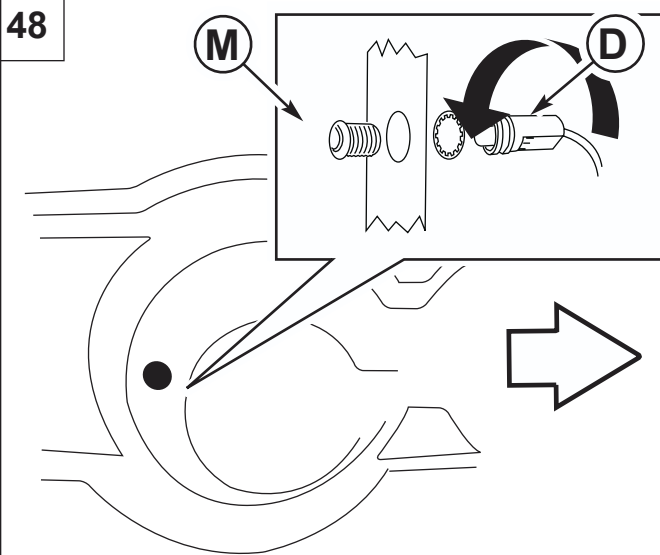

49

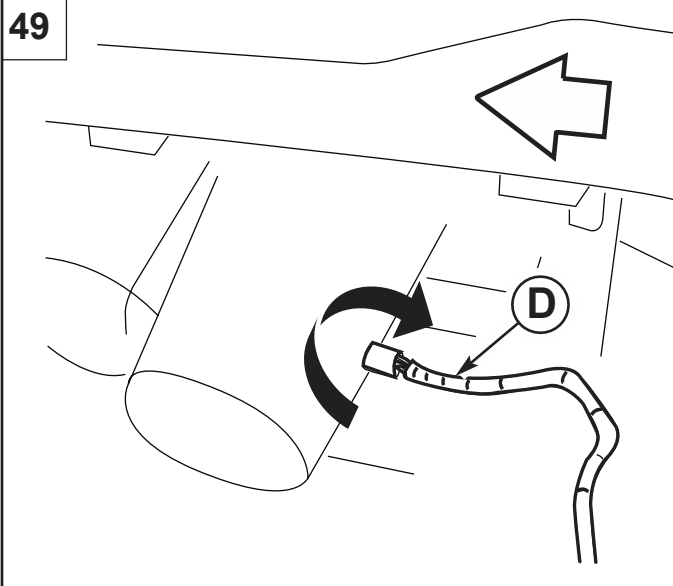

50

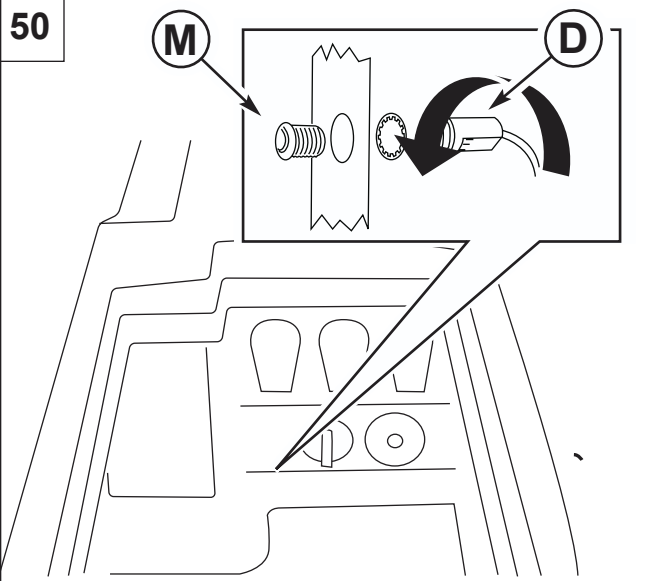

51

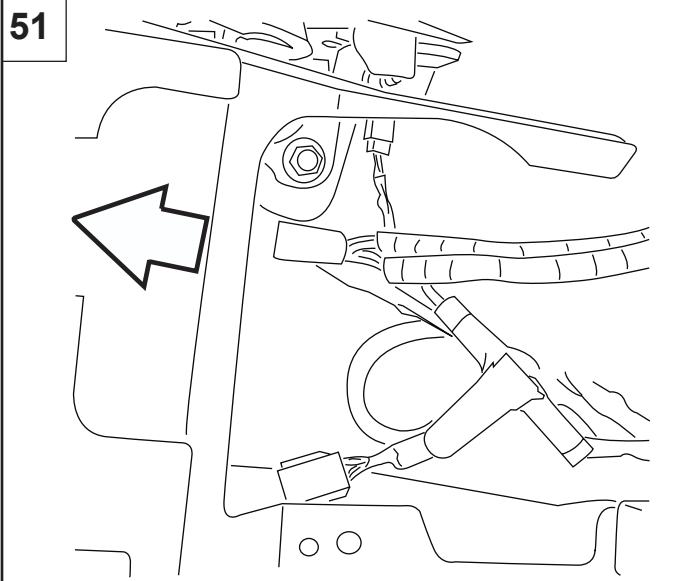

52

NOTE: SECURE LOOSE WIRES USING FOAM PADS AND CABLE TIES. PROTECT ROUGH EDGES WITH FLOCK TAPE.

NOTA: ASEGURE LOS CABLE USANDO "FOAM" Y CABLES. PROTEJA LAS ESQUINAS CON LA CINTA AFIELTRADA "FLOC"

REMARQUÉ: INSTALLÉ SOLIDEMENT LES FILS DÉTACHÉ. FAIT ATTENTION AUX BORDS, GARGEZ AVEC DU "FLOC"

53

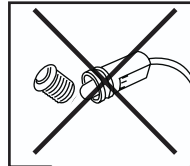

NOTE: REINSTALL CONSOLE CAREFULLY

NOTA: REINSTALA LA CONSOLA CUIDADOSAMENTE

REMARQUÉ: RE-INSTALLEZ SOIGNEUSEMENT

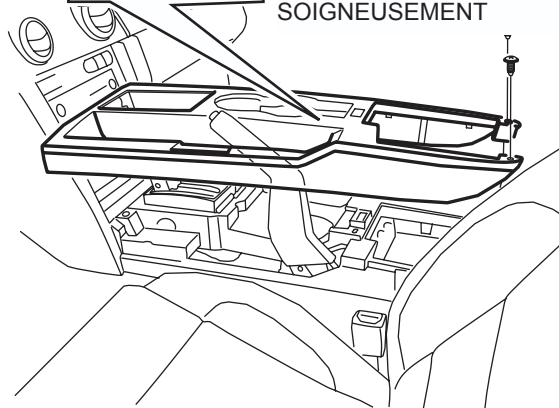

54

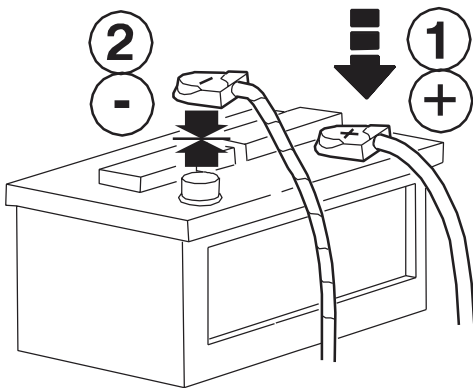

55

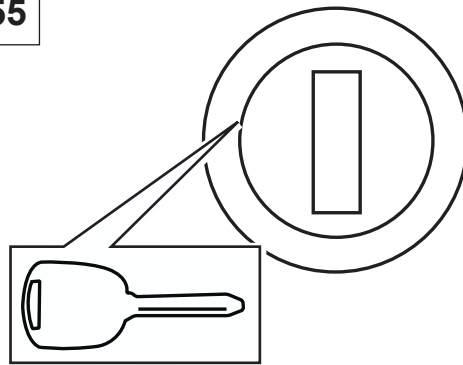

NOTE: TURN ON PARKING LIGHTS

NOTA: PRENDE LAS LUCES DE ESTACIONAMIENTO

REMARQUÉ: ALUMEZ LES LUMIÈRE DE STATIONNEMENT

56

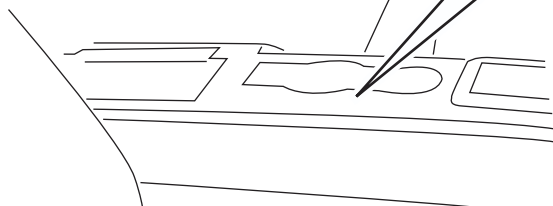
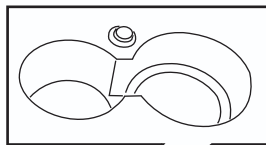

NOTE: CYCLE THROUGH 7 COLORS THEN "OFF"

NOTA: CICLE POR 7 COLORES Y LUEGO APAGE

REMARQUE: CYCLE LES 7 COULEURS JUSQU'À LA POSITION "ARRÊT"

57

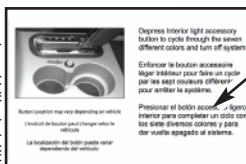

E

NOTE: LEAVE CUSTOMER QUICK REFERENCE CARD (E).

NOTA: DEJE AL CLIENTE LA TARJETA DE LA REFERENCIA RAPIDA(E).

REMARQUÉ: LAISSEZ À CLIENT LS CARTE RAPIDE DE RÉFÉRENCE (E).

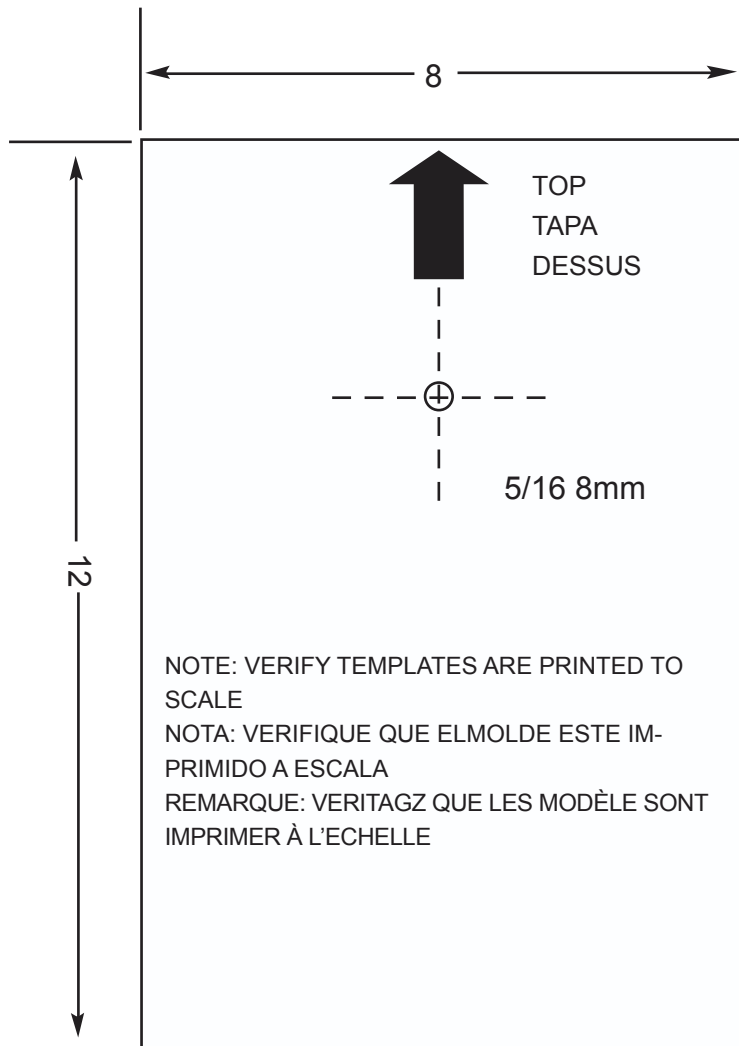

CUPHOLDER TEMPLATE
 MOLDE SOSTENEDOR DE TAZA
 PORTE-TASSE GABARIT

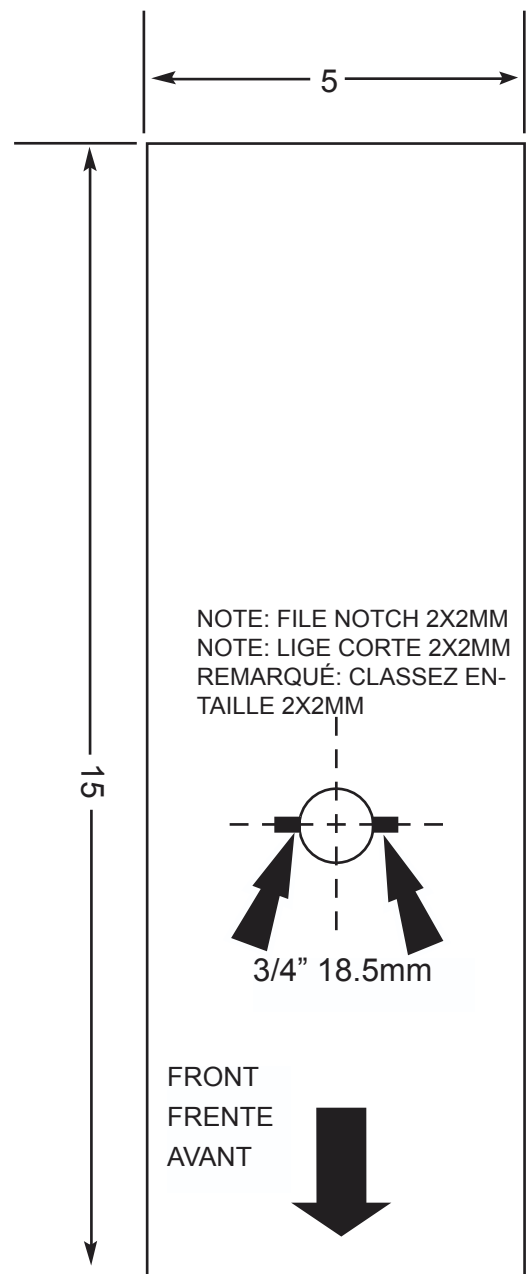

SWITCH TEMPLATE
 MOLDE INTERRUPTOR
 BOUTON ELECTRIQUE GABARIT

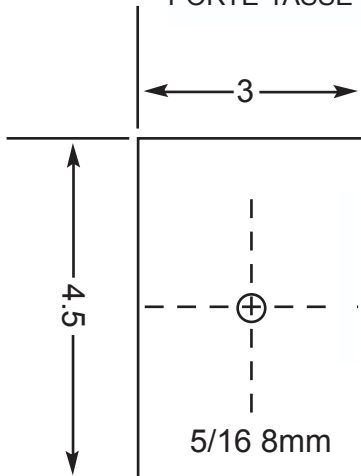

STORAGE TEMPLATE
 MOLDE ALMACENAJE
 ENTREPOSAGE GABARIT

NOTE: DO NOT SCALE WHEN PRINTING

NOTA: NO ESCALE AL IMPRIMIR

REMARQUE: NE MESUREZ PAS EN IMPRIMANT

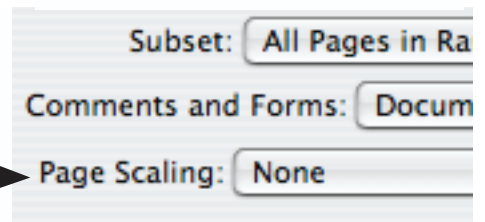

cm

1:1

MUSTANG

Congratulations!

You've purchased a Genuine Ford Brand Accessory designed, engineered, and built specifically for your Ford vehicle. We have made every effort to ensure that the Interior LED Lighting kit is top quality in terms of fit, durability, finish and ease of installation.

At Ford Customer Service Division,
customer satisfaction is our number one priority!

¡Felicidades!

Acaba de comprar un Accesorio marca Ford Genuino, diseñado y construido específicamente para su vehículo Ford. Hemos realizado todos los esfuerzos necesarios para el interior del kit la luz LED sea de la mejor calidad en cuanto a ajuste, durabilidad acabado y facilidad de instalación.

Para la División de Atención al Cliente de Ford,
la satisfacción del cliente es nuestra principal prioridad.

Félicitations !

Vous avez acheté un accessoire Ford d'origine conçu, étudié et fabriqué spécialement pour votre véhicule Ford. Nous avons pris toutes les mesures nécessaires pour assurer que ce LED Kit de lumière en intérieur est d'une qualité supérieure en ce qui concerne l'ajustement, la durabilité, la finition et la facilité d'installation.

Pour la division du service à la clientèle Ford, la satisfaction du client a priorité absolue !



Ford Customer Service Division



**ACCESSORIZE YOUR VEHICLE AT:
FORDACCESSORIESSTORE.COM**

